

LOCATION MAP
SEC. 3, 9 & 10, T52N., R34W.
(N.T.S.)

FINAL PLAT OF
KCI 29 LOGISTICS PARK SECOND PLAT
SW 1/4, SEC 3, T52N, R34W
NE 1/4, SEC 9, T52N, R34W
SE 1/4, NE 1/4 & NW 1/4, SEC 10, T52N, R34W
KANSAS CITY, PLATTE COUNTY, MISSOURI

| | |
|--|-------------------------------------|
| PLAT DEDICATION: KCI 29 LOGISTICS PARK SECOND PLAT | RESERVED FOR COUNTY RECORDING STAMP |
| PRIVATE OPEN SPACE DEDICATION: N/A | |
| RECORD AS: PLAT | |

PROPERTY DESCRIPTION

ALL OF LOT 3 AND TRACT A, OF KCI 29 LOGISTICS PARK FIRST PLAT, A SUBDIVISION OF LAND IN THE NORTHWEST QUARTER, NORTHEAST AND SOUTHWEST QUARTER OF SECTION 9, AND NORTHWEST QUARTER AND SOUTHWEST QUARTER OF SECTION 10, ALL IN TOWNSHIP 52 NORTH, RANGE 34 WEST OF THE 5TH PRINCIPAL MERIDIAN IN KANSAS CITY, PLATTE COUNTY MISSOURI RECORDED DECEMBER 20, 2023 AS INSTRUMENT NUMBER 2023012474 IN BOOK 23 AT PAGE 78 IN THE OFFICE OF RECORDER OF DEEDS, PLATTE COUNTY, MISSOURI AND UN-PLATTED TRACT OF LAND IN SAID NORTHWEST QUARTER, SAID NORTHEAST QUARTER AND SOUTHWEST QUARTER OF SAID SECTION 10, AND SOUTHWEST QUARTER OF SECTION 3, ALL IN SAID TOWNSHIP 52 NORTH AND SAID RANGE 34 WEST OF SAID 5TH PRINCIPAL MERIDIAN IN SAID KANSAS CITY BEING BOUNDED AND DESCRIBED BY OR UNDER THE DIRECT SUPERVISION OF JASON S ROUBEUSH, P.L.S. 2002014092 AS FOLLOWS: COMMENCING AT THE NORTHWEST CORNER OF SAID NORTHEAST QUARTER OF SAID SECTION 10, ALSO BEING THE NORTHEAST CORNER OF SAID NORTHWEST QUARTER OF SAID SECTION 10, ALSO BEING THE SOUTHWEST CORNER OF SAID SOUTHWEST QUARTER OF SAID SECTION 3, AND ALSO BEING THE SOUTHWEST CORNER OF SAID SOUTHWEST QUARTER OF SAID SECTION 3; THENCE SOUTH 00°28'01" WEST, ON THE EAST LINE OF SAID NORTHWEST QUARTER OF SAID SECTION 10, ALSO BEING THE WEST LINE OF SAID NORTHEAST QUARTER OF SAID SECTION 10, A DISTANCE OF 2,636.70 FEET TO A POINT ON THE EXISTING NORTHERLY RIGHT-OF-WAY LINE OF NW 132ND STREET, AS ESTABLISHED BY GENERAL WARRANTY DEED RECORDED MAY 18, 2023 AS INSTRUMENT NUMBER 2023004683 IN BOOK 1392 AT PAGE 898 IN SAID OFFICE OF RECORDER OF DEEDS, PLATTE COUNTY, MISSOURI, ALSO BEING THE POINT OF BEGINNING OF THE TRACT OF LAND TO BE HEREIN DESCRIBED; THENCE WESTERLY, ON SAID EXISTING NORTHERLY RIGHT-OF-WAY LINE, ON A CURVE TO THE RIGHT HAVING AN INITIAL TANGENT BEARING OF NORTH 83°09'47" WEST WITH A RADIUS OF 660.00 FEET, A CENTRAL ANGLE OF 00°34'42" AND AN ARC DISTANCE OF 6.66 FEET TO THE EASTERN MOST CORNER OF TRACT B, OF SAID KCI 29 LOGISTICS PARK FIRST PLAT; THENCE ALONG A LINE NON-TANGENT TO SAID CURVE, NORTH 30°15'58" WEST, ON THE NORTHEASTERLY LINE OF SAID TRACT B, 218.16 FEET; THENCE NORTH 61°27'24" WEST, ON SAID NORTHEASTERLY LINE, 192.72 FEET; THENCE NORTH 02°06'52" EAST, ON SAID NORTHEASTERLY LINE, 201.89 FEET; THENCE SOUTH 87°15'13" WEST, ON SAID NORTHEASTERLY LINE, 179.10 FEET; THENCE SOUTH 87°15'13" WEST, ON SAID NORTHEASTERLY LINE, 179.10 FEET; THENCE NORTH 36°21'37" WEST, ON SAID NORTHEASTERLY LINE, 390.77 FEET; THENCE NORTH 51°08'12" WEST, ON SAID NORTHEASTERLY LINE, 444.61 FEET; THENCE NORTH 04°26'43" WEST, ON SAID NORTHEASTERLY LINE, 166.70 FEET TO THE NORTHEAST CORNER OF SAID TRACT B ALSO BEING THE NORTHEAST CORNER OF N. MEXICO CITY AVENUE RIGHT-OF-WAY LINE, ESTABLISHED BY SAID GENERAL WARRANTY DEED; THENCE NORTH 60°42'18" WEST, ON THE EXISTING NORTHERLY RIGHT-OF-WAY LINE OF SAID N. MEXICO CITY AVENUE, 164.79 FEET TO THE NORTHWEST CORNER OF N. MEXICO CITY AVENUE RIGHT-OF-WAY LINE, ESTABLISHED BY SAID GENERAL WARRANTY DEED, ALSO BEING THE NORTHEAST CORNER OF SAID TRACT A; THENCE SOUTHWESTERLY, ON THE EXISTING WESTERLY RIGHT-OF-WAY LINE OF SAID N. MEXICO CITY AVENUE, ESTABLISHED BY SAID GENERAL WARRANTY, ALSO BEING THE EASTERLY LINE OF SAID TRACT A AND EASTERLY LINE OF SAID LOT 3, ON A CURVE TO THE LEFT HAVING AN INITIAL TANGENT BEARING OF SOUTH 40°41'02" WEST WITH A RADIUS OF 886.00 FEET, A CENTRAL ANGLE OF 23°16'15" AND AN ARC DISTANCE OF 359.85 FEET; THENCE SOUTH 17°24'47" WEST, ON SAID EXISTING WESTERLY RIGHT-OF-WAY LINE, AND SAID EASTERLY LINE OF SAID LOT 3, A DISTANCE OF 7.48 FEET; THENCE SOUTHERLY, ON SAID EXISTING WESTERLY RIGHT-OF-WAY LINE AND SAID EASTERLY LINE, ON A CURVE TO THE LEFT BEING TANGENT TO THE LAST DESCRIBED COURSE WITH A RADIUS OF 886.00 FEET, A CENTRAL ANGLE OF 01°19'25" AND AN ARC DISTANCE OF 20.47 FEET; THENCE SOUTHWESTERLY ON SAID EXISTING WESTERLY RIGHT-OF-WAY LINE AND SAID EASTERLY LINE, ON A CURVE TO THE RIGHT HAVING A COMMON TANGENT WITH THE LAST DESCRIBED COURSE WITH A RADIUS OF 65.00 FEET, A CENTRAL ANGLE OF 86°59'09" AND AN ARC DISTANCE OF 98.68 FEET TO A POINT ON THE EXISTING NORTHEASTERLY RIGHT-OF-WAY LINE OF NW. ROANRIDGE ROAD ESTABLISHED BY SAID GENERAL WARRANTY DEED; THENCE NORTH 76°55'30" WEST, ON SAID EXISTING NORTHEASTERLY RIGHT-OF-WAY LINE, ALSO BEING THE SOUTHERLY LINE OF SAID LOT 3, A DISTANCE 23.29 FEET; THENCE WESTERLY, ON SAID EXISTING NORTHEASTERLY RIGHT-OF-WAY LINE AND SAID SOUTHERLY LINE, ON A CURVE TO THE LEFT BEING TANGENT TO THE LAST DESCRIBED COURSE WITH A RADIUS OF 773.00 FEET, A CENTRAL ANGLE OF 40°09'07" AND AN ARC DISTANCE OF 541.71 FEET; THENCE SOUTHWESTERLY, ON SAID EXISTING NORTHEASTERLY RIGHT-OF-WAY LINE AND SAID SOUTHERLY LINE, ON A CURVE TO THE LEFT HAVING A COMMON TANGENT WITH THE LAST DESCRIBED COURSE WITH A RADIUS OF 545.00 FEET, A CENTRAL ANGLE OF 18°40'18" AND AN ARC DISTANCE OF 177.61 FEET; THENCE SOUTH 44°15'05" WEST, ON SAID EXISTING NORTHEASTERLY RIGHT-OF-WAY LINE AND SAID SOUTHERLY LINE, 72.99 FEET; THENCE SOUTHWESTERLY, ON SAID EXISTING NORTHEASTERLY RIGHT-OF-WAY LINE AND SAID SOUTHERLY LINE, ON A CURVE TO THE LEFT BEING TANGENT TO THE LAST DESCRIBED COURSE WITH A RADIUS OF 761.00 FEET, A CENTRAL ANGLE OF 01°24'09" AND AN ARC DISTANCE OF 18.63 FEET TO THE SOUTHERN MOST POINT OF SAID LOT 3, ALSO BEING THE EASTERN MOST POINT OF LOT 2, OF SAID KCI 29 LOGISTICS PARK FIRST PLAT; THENCE LEAVING SAID EXISTING NORTHEASTERLY RIGHT-OF-WAY, NORTH 13°09'59" WEST, ON THE WESTERLY LINE OF SAID LOT 3, ALSO BEING THE EASTERLY LINE OF SAID LOT 2, A DISTANCE OF 638.30 FEET TO THE NORTHEAST CORNER OF SAID LOT 2, ALSO BEING A POINT ON THE SOUTHERLY LINE OF SAID TRACT A; THENCE NORTH 67°55'00" WEST, ON SAID SOUTHERLY LINE, ALSO BEING THE NORTHERLY LINE OF SAID LOT 2, A DISTANCE OF 1,665.49 FEET; THENCE SOUTH 75°48'40" WEST, ON SAID SOUTHERLY LINE AND SAID NORTHERLY LINE, 43.88 FEET; THENCE SOUTH 29°58'16" WEST, ON SAID SOUTHERLY LINE AND SAID NORTHERLY LINE, 91.90 FEET; THENCE NORTH 68°05'50" WEST, ON SAID SOUTHERLY LINE AND SAID NORTHERLY LINE, 686.69 FEET; THENCE NORTH 87°24'53" WEST, ON SAID SOUTHERLY LINE AND SAID NORTHERLY LINE, 429.45 FEET TO THE SOUTHWEST CORNER OF SAID TRACT A; THENCE NORTH 00°47'32" WEST, ON SAID NORTHERLY LINE, ALSO BEING THE WEST LINE OF SAID TRACT A, 293.22 FEET TO THE NORTHWEST CORNER OF SAID TRACT A; THENCE LEAVING SAID NORTHERLY LINE, NORTH 89°12'28" EAST, ON THE NORTHERLY LINE OF SAID TRACT A, 393.32 FEET; THENCE SOUTH 54°44'47" EAST, ON SAID NORTHERLY LINE, 196.04 FEET; THENCE SOUTH 77°14'09" EAST, ON SAID NORTHERLY LINE, 155.29 FEET; THENCE NORTH 36°46'07" EAST, ON SAID NORTHERLY LINE, 119.94 FEET; THENCE SOUTH 87°08'48" EAST, ON SAID NORTHERLY LINE, 169.74 FEET; THENCE SOUTH 18°11'33" EAST, ON SAID NORTHERLY LINE, 168.25 FEET; THENCE SOUTH 84°24'29" EAST, ON SAID NORTHERLY LINE, 285.55 FEET; THENCE NORTH 71°25'28" EAST, ON SAID NORTHERLY LINE, 269.96 FEET; THENCE SOUTH 62°35'14" EAST ON SAID NORTHERLY LINE, 291.18 FEET; THENCE SOUTH 66°21'26" EAST, ON SAID NORTHERLY LINE, 622.48 FEET; THENCE NORTH 23°38'34" EAST, ON SAID NORTHERLY LINE, 193.24 FEET; THENCE NORTH 84°22'19" EAST, ON SAID NORTHERLY LINE, 117.07 FEET; THENCE SOUTH 05°37'41" EAST, ON SAID NORTHERLY LINE, 112.23 FEET; THENCE NORTH 82°54'32" EAST, ON SAID NORTHERLY LINE, 202.67 FEET; THENCE LEAVING SAID NORTHERLY LINE, NORTH 00°47'32" WEST, 457.24 FEET; THENCE NORTH 89°12'28" EAST, 644.31 FEET; THENCE NORTH 00°47'32" WEST, 105.00 FEET; THENCE NORTH 89°12'28" EAST, 118.84 FEET; THENCE NORTH 83°29'49" EAST, 92.02 FEET; THENCE NORTHEASTERLY, ON A CURVE TO THE LEFT BEING TANGENT TO THE LAST DESCRIBED COURSE WITH A RADIUS OF 70.00 FEET, A CENTRAL ANGLE OF 82°59'59" AND AN ARC DISTANCE OF 101.40 FEET; THENCE NORTH 00°29'51" WEST, 136.98 FEET; THENCE SOUTH 89°30'09" EAST, 144.00 FEET; THENCE SOUTH 00°29'51" EAST, 132.51 FEET; THENCE SOUTHEASTERLY, ON A CURVE TO THE LEFT BEING TANGENT TO THE LAST DESCRIBED COURSE WITH A RADIUS OF 65.00 FEET, A CENTRAL ANGLE OF 91°17'23" AND AN ARC DISTANCE OF 103.56 FEET; THENCE NORTH 89°12'28" EAST, 452.49 FEET; THENCE SOUTH 87°59'18" EAST, 367.94 FEET; THENCE NORTH 89°12'28" EAST, 363.00 FEET; THENCE NORTH 89°49'32" EAST, 1,463.34 FEET; THENCE SOUTH 00°10'28" EAST, 2,746.35 FEET TO POINT ON THE EXISTING NORTHERLY RIGHT-OF-WAY LINE OF NW. 132ND STREET, ESTABLISHED BY GENERAL WARRANTY DEED RECORDED NOVEMBER 18, 1987 AS INSTRUMENT NUMBER 049132 IN BOOK 711 AT PAGE 502 IN SAID OFFICE OF RECORDER OF DEEDS, PLATTE COUNTY, MISSOURI; THENCE SOUTH 89°46'03" WEST, ON SAID EXISTING NORTHERLY RIGHT-OF-WAY LINE, 480.83 FEET; THENCE WESTERLY, ON SAID EXISTING NORTHERLY RIGHT-OF-WAY LINE, ON A CURVE TO THE RIGHT BEING TANGENT TO THE LAST DESCRIBED COURSE WITH A RADIUS OF 1,033.52 FEET, A CENTRAL ANGLE OF 15°54'31" AND AN ARC DISTANCE OF 286.96 FEET; THENCE NORTH 74°19'26" WEST, ON SAID EXISTING NORTHERLY RIGHT-OF-WAY LINE, 286.67 FEET; THENCE WESTERLY, ON SAID EXISTING NORTHERLY RIGHT-OF-WAY LINE, ON A CURVE TO THE LEFT BEING TANGENT TO THE LAST DESCRIBED COURSE WITH A RADIUS OF 1,092.38 FEET, A CENTRAL ANGLE OF 15°54'31" AND AN ARC DISTANCE OF 303.31 FEET TO A POINT ON THE SOUTH LINE OF SAID NORTHEAST QUARTER OF SAID SECTION 10, ALSO BEING THE NORTH LINE OF SAID SOUTHWEST QUARTER OF SAID SECTION 10; THENCE SOUTH 89°46'03" WEST, ON SAID EXISTING NORTHERLY RIGHT-OF-WAY LINE, SAID SOUTH LINE AND SAID NORTH LINE, 153.89 FEET TO THE CENTER OF SAID SECTION 10, ALSO BEING A POINT ON THE EXISTING EASTERLY RIGHT-OF-WAY LINE OF NW. 132ND STREET ESTABLISHED BY SAID GENERAL WARRANTY DEED, INSTRUMENT NUMBER 2023004683 IN BOOK 1392 AT PAGE 898; THENCE LEAVING SAID EXISTING NORTHERLY RIGHT-OF-WAY LINE ESTABLISHED BY SAID GENERAL WARRANTY DEED INSTRUMENT NUMBER 049132 IN BOOK 711 AT PAGE 502, NORTH 00°28'01" EAST, ON SAID EXISTING EASTERLY RIGHT-OF-WAY LINE, ALSO BEING THE WEST LINE OF SAID NORTHEAST QUARTER OF SAID SECTION 10, ALSO BEING THE EAST LINE OF SAID NORTHWEST QUARTER OF SECTION 10, A DISTANCE OF 11.33 FEET TO THE POINT OF BEGINNING. ALL LYING ABOVE THE WINTERSSET LEDGE OF LIMESTONE ROCK. IN AREAS WHERE THE WINTERSSET LEDGE IS ABSENT, ALL LYING ABOVE THE BETHANY FALLS LEDGE OF LIMESTONE ROCK. IN AREAS WHERE THE BETHANY FALLS LEDGE IS ABSENT, ALL LYING ABOVE THE ELEVATION 720 (NAVD88). CONTAINING 9,134,162 SQUARE FEET OR 209.69 ACRES, MORE OR LESS.

| BOUNDARY LINE TABLE | | |
|---------------------|-------------|-----------|
| BOUNDARY LINE ID | BEARING | DISTANCE |
| 1 | S00°28'01"W | 2,636.70' |
| 2 | N30°15'58"W | 218.16' |
| 3 | N61°27'24"W | 192.72' |
| 4 | N02°06'52"E | 201.89' |
| 5 | S87°15'13"W | 179.10' |
| 6 | N36°21'37"W | 390.77' |
| 7 | N51°08'12"W | 444.61' |
| 8 | N04°26'43"W | 166.70' |
| 9 | N60°42'18"W | 164.79' |
| 10 | S17°24'47"W | 7.48' |
| 11 | N76°55'30"W | 23.29' |
| 12 | S44°15'05"W | 72.99' |
| 13 | N13°09'59"W | 638.30' |
| 14 | N67°55'00"W | 1,665.49' |
| 15 | S75°48'40"W | 43.88' |
| 16 | S29°58'16"W | 91.90' |
| 17 | N68°05'50"W | 686.69' |
| 18 | N87°24'53"W | 429.45' |
| 19 | N00°47'32"W | 293.22' |
| 20 | N89°12'28"E | 393.32' |
| 21 | S54°44'47"E | 196.04' |
| 22 | S77°14'09"E | 155.29' |
| 23 | N36°46'07"E | 119.94' |
| 24 | S87°08'48"E | 169.74' |
| 25 | S18°11'33"E | 168.25' |
| 26 | S84°24'29"E | 285.55' |
| 27 | N71°25'28"E | 269.96' |
| 28 | S62°35'14"E | 291.18' |
| 29 | S66°21'26"E | 622.48' |
| 30 | N23°38'34"E | 193.24' |
| 31 | N84°22'19"E | 117.07' |
| 32 | S05°37'41"E | 112.23' |
| 33 | N82°54'32"E | 202.67' |
| 34 | N00°47'32"W | 457.24' |
| 35 | N89°12'28"E | 644.31' |
| 36 | N00°47'32"W | 105.00' |
| 37 | N89°12'28"E | 118.84' |
| 38 | N83°29'49"E | 92.02' |
| 39 | N00°29'51"W | 136.98' |
| 40 | S89°30'09"E | 144.00' |
| 41 | S00°29'51"E | 132.51' |
| 42 | N89°12'28"E | 452.49' |
| 43 | S87°59'18"E | 367.94' |
| 44 | N89°12'28"E | 363.00' |
| 45 | N89°49'32"E | 1,463.34' |
| 46 | S00°10'28"E | 2,746.35' |
| 47 | S89°46'03"W | 480.83' |
| 48 | N74°19'26"W | 286.67' |
| 49 | S89°46'03"W | 153.89' |
| 50 | N00°28'01"E | 11.33' |

| LEGEND | |
|--------|---------------------|
| ○ FND | FOUND MONUMENT |
| ● SCR | SECTION CORNER |
| ● SET | SET MONUMENT |
| ○ ROW | RIGHT OF WAY MARKER |
| --- | BOUNDARIES |
| --- | SECTION LINE |

| LAND DATA | | AREA |
|---|---------------|------|
| TOTAL LAND AREA | 209.69 ACRES± | |
| LAND AREA FOR PROPOSED OR EXISTING RIGHT-OF-WAY | 11.08 ACRES± | |
| NET LAND AREA | 198.61 ACRES± | |

| PLAT DATA | | COUNT |
|------------------|---|-------|
| NUMBER OF LOTS | 3 | |
| NUMBER OF TRACTS | 2 | |

| BOUNDARY CURVE TABLE | | | | |
|----------------------|-------------------------|-----------|-----------|---------|
| BOUNDARY CURVE ID | INITIAL TANGENT BEARING | RADIUS | DELTA | LENGTH |
| 2 | N83°09'47"W | 660.00' | 00°34'42" | 6.66' |
| 11 | S40°41'02"W | 886.00' | 23°16'15" | 359.85' |
| 13 | --- | 886.00' | 01°19'25" | 20.47' |
| 14 | --- | 65.00' | 86°59'09" | 98.68' |
| 16 | --- | 773.00' | 40°09'07" | 541.71' |
| 17 | --- | 545.00' | 18°40'18" | 177.61' |
| 19 | --- | 761.00' | 01°24'09" | 18.63' |
| 46 | --- | 70.00' | 82°59'59" | 101.40' |
| 50 | --- | 65.00' | 91°17'23" | 103.56' |
| 57 | --- | 1,033.52' | 15°54'31" | 286.96' |
| 59 | --- | 1,092.38' | 15°54'31" | 303.31' |

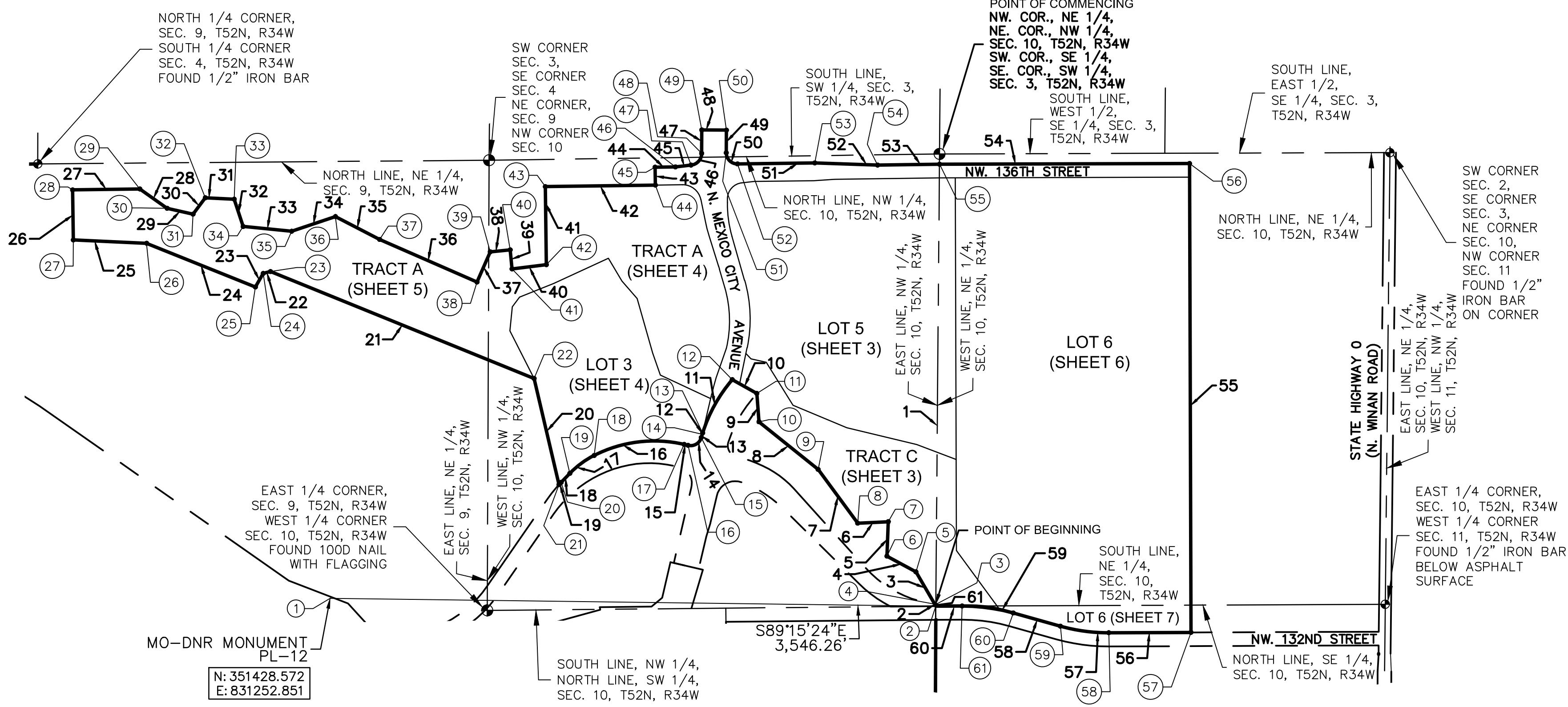

THIS PLAT AND SURVEY OF KCI 29 LOGISTICS PARK SECOND PLAT WERE EXECUTED BY OLSSON, 1301 BURLINGTON STREET #100, NORTH KANSAS CITY, MISSOURI 64116.

I HEREBY CERTIFY THAT THE PLAT OF KCI 29 LOGISTICS PARK SECOND PLAT SUBDIVISION IS BASED ON AN ACTUAL SURVEY MADE BY ME OR UNDER MY DIRECT SUPERVISION AND THAT SAID SURVEY MEETS OR EXCEEDS THE CURRENT MISSOURI STANDARDS FOR PROPERTY BOUNDARY SURVEYS AS ESTABLISHED BY THE MISSOURI BOARD FOR ARCHITECTS, PROFESSIONAL ENGINEERS, PROFESSIONAL SURVEYORS AND LANDSCAPE ARCHITECTS AND THE MISSOURI DEPARTMENT OF AGRICULTURE. I FURTHER CERTIFY THAT I HAVE COMPLIED WITH ALL STATUTES, ORDINANCES, AND REGULATIONS GOVERNING THE PRACTICE OF SURVEYING AND PLATTING OF SUBDIVISIONS TO THE BEST OF MY PROFESSIONAL KNOWLEDGE AND BELIEF.



OLSSON, MO CLS 366
Jason Roudebush, MO PLS 2002014092
APRIL 30, 2024
JROUDEBUSH@OLSSON.COM

| DATE OF SURVEY | |
|----------------|---|
| 03-10-2024 | To HMW for Review |
| 03-11-2024 | - 1st Submittal |
| 03-18-2024 | - Title Report Request |
| 04-03-2024 | - To HMW for Review |
| 04-05-2024 | - 2nd Submittal |
| 04-29-2024 | - Revised Plat Boundary to HMW for Review |
| 04-30-2024 | - 3rd Submittal |

drawn by: NRW
surveyed by: AHNZRN.TG
checked by: JPM
approved by: JSR
project no.: B21-06168
file name: V_PLAT_B2106168.DWG

DWG: F:\2021\06001-06500\021-06168-B\40-Design\Survey\SRV\Sheets\Plat\V_PLAT_B2106168.dwg
USER: nwilloughby
DATE: Apr 30, 2024 6:51PM

FINAL PLAT OF
KCI 29 LOGISTICS PARK SECOND PLAT
SW 1/4, SEC 3, T52N, R34W
NE 1/4, SEC 9, T52N, R34W
SE 1/4, NE 1/4 & NW 1/4, SEC 10, T52N, R34W
KANSAS CITY, PLATTE COUNTY, MISSOURI

IN WITNESS WHEREOF:

MC WINAN ROAD, LLC A MISSOURI LIMITED LIABILITY COMPANY
LICENSED TO DO BUSINESS IN THE STATE OF MISSOURI, HAS
CAUSED THESE PRESENTS TO BE EXECUTED THIS _____ DAY
OF _____ 20____

MC WINAN ROAD, LLC
A MISSOURI LIMITED LIABILITY COMPANY

BY: BLANKENBAKER LOGISTICS LLC
A KENTUCKY LIMITED LIABILITY COMPANY,
ITS SOLE MEMBER

BY: HUNT MIDWEST REAL ESTATE DEVELOPMENT, INC.
ITS SOLE MEMBER

BY: _____
VINCENT T. JOHNSTON, SENIOR VICE PRESIDENT

STATE OF _____ SS:
COUNTY OF _____

BE IT REMEMBERED THAT ON THIS _____ DAY OF
_____, 20____, BEFORE ME, THE UNDERSIGNED, A
NOTARY PUBLIC IN AND FOR THE COUNTY AND STATE
AFORESAID, CAME VINCENT T. JOHNSTON TO ME PERSONALLY
KNOWN, WHO BEING BY ME DULY SWORN, DID SAY THAT HE IS
SENIOR VICE PRESIDENT OF HUNT MIDWEST REAL ESTATE
DEVELOPMENT, INC, A SOLE MEMBER OF BLANKENBAKER
LOGISTICS LLC, A KENTUCKY LIMITED LIABILITY COMPANY, A
SOLE MEMBER OF MC WINAN ROAD, LLC, A MISSOURI LIMITED
LIABILITY COMPANY, AND THAT SAID INSTRUMENT WAS SIGNED
IN BEHALF OF SAID LIMITED LIABILITY COMPANY AND THAT SAID
VINCENT T. JOHNSTON, ACKNOWLEDGED SAID INSTRUMENT TO
BE THE FREE ACT AND DEED OF SAID LIMITED LIABILITY
COMPANY.

IN WITNESS WHEREOF:

I HAVE HEREUNTO SET MY HAND AND AFFIXED MY NOTARIAL
SEAL IN THE DATE HEREIN LAST ABOVE WRITTEN.

MY COMMISSION EXPIRES: _____

NOTARY PUBLIC

CITY PLAN COMMISSION:

APPROVED DATE: _____
CASE NUMBER: _____

PUBLIC WORKS:

MICHAEL J. SHAW
DIRECTOR OF PUBLIC WORKS

CITY COUNCIL:

THIS IS TO CERTIFY THAT THE WITHIN PLAT WAS DULY
SUBMITTED TO AND APPROVED BY THE COUNCIL OF KANSAS
CITY, MISSOURI, BY ORDINANCE NO. _____ DULY
AUTHENTICATED AS PASSED THIS _____ DAY OF _____, 20____.

MAYOR
QUINTON LUCAS

CITY CLERK
MARILYN SANDERS

PLAT DEDICATION:

THE UNDERSIGNED OWNERS OF THE ABOVE DESCRIBED TRACT OF LAND HAVE
CAUSED THE SAME TO BE SUBDIVIDED IN THE MANNER AS SHOWN ON THE
ACCOMPANYING PLAT, WHICH SUBDIVISION AND PLAT SHALL HEREAFTER BE KNOWN
AS:

KCI 29 LOGISTICS PARK SECOND PLAT

SURVEYORS NOTES:

1. PROPERTY INFORMATION REFERENCING THIS SURVEY WAS TAKEN FROM THE COMMITMENT
FOR TITLE INSURANCE REPORT, ISSUED BY CHICAGO TITLE INSURANCE COMPANY,
COMMITMENT NO. KCC240449, WITH A COMMITMENT DATE OF MARCH 22, 2024 AT 8:00 A.M.

2. BEARINGS USED HEREON ARE BASED ON THE MISSOURI STATE PLANE COORDINATE
SYSTEM, NAD 1983, WEST ZONE USING MISSOURI DEPARTMENT OF NATURAL RESOURCES
MONUMENT "PL-12" WITH A GRID FACTOR OF 0.9999034. ALL COORDINATES SHOWN ARE IN
METERS.

3. THE TERM "PER PLAT" IS IN REFERENCE TO KCI LOGISTICS PARK FIRST PLAT, RECORDED
DECEMBER 20, 2023 AS INSTRUMENT NUMBER 2023012474 IN BOOK 23 AT PAGE 78 IN
PLATTE COUNTY, MISSOURI.

4. NO BUILDINGS WITHIN 20' R/W, 10' OF REAR AND SIDE LINES OF LOT 3 AND TRACT A,
KCI 29 LOGISTICS PARK FIRST PLAT PER ARTICLE V MINIMUM BUILDING AND SETBACK LINES,
MAXIMUM HEIGHT DECLARATIONS SECTION 5.01 PER COVENANTS, CONDITIONS & RESTRICTIONS
AFFECTING PROPERTY WITHIN KCI 29 LOGISTICS PARK DOCUMENT RECORDED DECEMBER 20,
2023 AS INSTRUMENT # 2023012477 IN BOOK 1400 AT PAGE 632.

STATE PLANE COORDINATE TABLE

| Point Number | Grid Northing | Grid Easting |
|--------------|---------------|--------------|
| 1 | 351429.575 | 831251.631 |
| 2 | 351415.552 | 832332.384 |
| 3 | 351419.006 | 832332.412 |
| 4 | 351419.258 | 832330.396 |
| 5 | 351476.687 | 832296.883 |
| 6 | 351504.753 | 832245.284 |
| 7 | 351566.246 | 832247.554 |
| 8 | 351563.630 | 832193.031 |
| 9 | 351659.543 | 832122.420 |
| 10 | 351744.570 | 832016.906 |
| 11 | 351795.224 | 832012.969 |
| 12 | 351819.799 | 831969.167 |
| 13 | 351724.576 | 831916.279 |
| 14 | 351722.400 | 831915.596 |
| 15 | 351716.426 | 831913.798 |
| 16 | 351702.619 | 831890.282 |
| 17 | 351704.225 | 831883.368 |
| 18 | 351684.510 | 831722.828 |
| 19 | 351652.520 | 831679.458 |
| 20 | 351636.584 | 831663.934 |
| 21 | 351632.470 | 831660.022 |
| 22 | 351821.900 | 831615.709 |
| 23 | 352012.741 | 831145.335 |
| 24 | 352009.463 | 831132.369 |
| 25 | 351985.199 | 831118.376 |
| 26 | 352063.272 | 830924.190 |
| 27 | 352069.176 | 830793.434 |
| 28 | 352158.535 | 830792.198 |
| 29 | 352160.193 | 830912.063 |
| 30 | 352125.705 | 830960.855 |
| 31 | 352115.248 | 831007.016 |
| 32 | 352144.532 | 831028.898 |
| 33 | 352141.956 | 831080.569 |
| 34 | 352093.240 | 831096.579 |
| 35 | 352084.759 | 831183.195 |
| 36 | 352110.970 | 831261.187 |
| 37 | 352070.110 | 831339.970 |
| 38 | 351994.026 | 831513.766 |
| 39 | 352047.980 | 831537.386 |
| 40 | 352051.479 | 831572.895 |
| 41 | 352017.438 | 831576.250 |
| 42 | 352025.063 | 831637.548 |
| 43 | 352164.408 | 831635.621 |
| 44 | 352167.124 | 831831.977 |
| 45 | 352199.123 | 831831.534 |
| 46 | 352199.624 | 831867.752 |
| 47 | 352202.801 | 831895.618 |
| 48 | 352223.813 | 831914.536 |
| 49 | 352265.562 | 831914.898 |
| 50 | 352265.181 | 831958.785 |
| 51 | 352224.795 | 831958.435 |
| 52 | 352204.814 | 831978.519 |
| 53 | 352206.721 | 832116.416 |
| 54 | 352202.784 | 832228.490 |
| 55 | 352204.314 | 832339.116 |
| 56 | 352205.671 | 832785.115 |
| 57 | 351368.633 | 832787.662 |
| 58 | 351368.039 | 832641.113 |
| 59 | 351379.753 | 832554.722 |
| 60 | 351403.361 | 832470.598 |
| 61 | 351415.742 | 832379.287 |

EASEMENT DEDICATION - AN EASEMENT IS HEREBY GRANTED TO KANSAS CITY, MISSOURI, FOR THE
PURPOSE OF LOCATING, CONSTRUCTING, OPERATING, AND MAINTAINING FACILITIES FOR WATER, GAS,
ELECTRICITY, SEWAGE, TELEPHONE, CABLE TV AND SURFACE DRAINAGE, AND GRADING, INCLUDING,
BUT NOT LIMITED TO, UNDERGROUND PIPES AND CONDUITS, PAD MOUNTED TRANSFORMERS, SERVICES
PEDESTALS, ANY OR ALL OF THEM UPON, OVER, UNDER AND ALONG THE STRIPS OF LAND
DESIGNATED UTILITY EASEMENTS (U.E.), PROVIDED THAT THE EASEMENT GRANTED HEREIN IS SUBJECT
TO ANY AND ALL EXISTING EASEMENTS. ANY UTILITIES LOCATED WITHIN THE DESIGNATED UTILITY
EASEMENTS, BY VIRTUE OF THEIR EXISTENCE, DO HEREBY COVENANT, CONSENT, AND AGREE THAT
THEY SHALL BE SUBORDINATE TO SAID PUBLIC RIGHT OF WAY IN THE EVENT THAT ADDITIONAL
PUBLIC RIGHT OF WAY IS DEDICATED OVER THE LOCATION OF THE UTILITY EASEMENT. WHERE OTHER
EASEMENTS ARE DESIGNATED FOR A PARTICULAR PURPOSE, THE USE THEREOF SHALL BE LIMITED TO
THAT PURPOSE ONLY. ALL OF THE ABOVE EASEMENTS SHALL BE KEPT FREE FROM ANY AND ALL
OBSTRUCTIONS WHICH WOULD INTERFERE WITH THE CONSTRUCTION OR RECONSTRUCTION AND
PROPER, SAFE AND CONTINUOUS MAINTENANCE OF THE AFORESAID USES AND SPECIFICALLY THERE
SHALL NOT BE BUILT THEREON OR THEREOVER ANY STRUCTURE (EXCEPT DRIVEWAYS, PAVED AREAS,
GRASS, SHRUBS AND FENCES) NOR SHALL THERE BE ANY OBSTRUCTION TO INTERFERE WITH THE
AGENTS AND EMPLOYEES OF KANSAS CITY, MISSOURI, AND ITS FRANCHISED UTILITIES FROM GOING
UPON SAID EASEMENT AND AS MUCH OF THE ADJOINING LANDS AS MAY BE REASONABLY NECESSARY
IN EXERCISING THE RIGHTS GRANTED BY THE EASEMENT. NO EXCAVATION OR FILL SHALL BE MADE
OR OPERATION OF ANY KIND OR NATURE SHALL BE PERFORMED WHICH WILL REDUCE OR INCREASE
THE EARTH COVERAGE OVER THE UTILITIES ABOVE STATED OR THE APPURTENANCES THERE TO,
WITHOUT A VALID PERMIT FROM THE DEPARTMENT OF PUBLIC WORKS AS TO UTILITY EASEMENTS,
AND/OR WRITTEN APPROVAL OF THE DIRECTOR OF WATER SERVICES AS TO WATER MAIN EASEMENTS.

DRAINAGE EASEMENT - A DRAINAGE EASEMENT (D.E.) FOR THE PURPOSE OF STORM WATER DRAINAGE
INCLUDING THE RIGHT TO BUILD, CONSTRUCT, KEEP, REPAIR AND MAINTAIN STORM WATER DRAINAGE
FACILITIES UNDER, IN, OVER, AND UPON AS NECESSARY, BEING AND SITUATED IN KANSAS CITY,
MISSOURI ("THE CITY") IS HEREBY GRANTED TO THE CITY. THE CITY SHALL HAVE THE RIGHT
AT ALL TIMES TO GO UPON THE LANDS HEREIN DESCRIBED TO CONSTRUCT, MAINTAIN AND REPAIR
THE SAID DRAINAGE FACILITIES AS MAY BE NECESSARY. NOTHING SHALL IN ANY WAY INTERFERE
WITH THE SAFE AND UNRESTRICTED USE OF THE LAND ADJACENT TO AND ABOVE SAID DRAINAGE
FACILITIES, NOR SHALL THE USE SAID PROPERTY IN SUCH MANNER AS WOULD INTERFERE WITH THE
PROPER, SAFE AND CONTINUOUS MAINTENANCE AND USE OF SAID DRAINAGE FACILITIES AND
SPECIFICALLY SHALL NOT BUILD THEREON OR THEREOVER ANY STRUCTURE WHICH MAY INTERFERE
WITH THE MAINTENANCE AND USE THEREOF.

WATER MAIN EASEMENT - A WATER MAIN EASEMENT (W.E.) FOR THE OPERATION AND MOVEMENT OF
EQUIPMENT, AND THE MOVEMENT OF A WORKING FORCE, IN CONNECTION WITH THE LOCATION,
CONSTRUCTION, RECONSTRUCTION, MAINTENANCE, OPERATION AND REPAIR OF WATER MAINS AND ALL
APPURTENANCES THERETO OVER, UNDER AND THROUGH LAND LYING, BEING, AND SITUATED IN
KANSAS CITY, MISSOURI ("THE CITY") IS HEREBY GRANTED TO THE CITY. THE CITY, ITS AGENTS,
EMPLOYEES OR INDEPENDENT CONTRACTORS SHALL HAVE THE RIGHT TO GO UPON THE ABOVE
DESCRIBED TRACTS OF LAND, FOR THE PURPOSE OF CONSTRUCTING, MAINTAINING, AND REPAIRING
THE WATER MAIN IMPROVEMENTS AND APPURTENANCES THERETO, AND SHALL UPON COMPLETION OF
SUCH CONSTRUCTION, MAINTENANCE OR REPAIR, CAUSE THE LAND TO BE RESTORED TO
SUBSTANTIALLY THE SAME CONDITION THAT EXISTED PRIOR TO THE CITY'S ENTRY UPON IT. THE
TRACT OF LAND OVER WHICH A WATER MAIN EASEMENT IS BEING GRANTED SHALL BE KEPT FREE
FROM BUILDINGS OR ANY OTHER STRUCTURES OR OBSTRUCTIONS (EXCEPT NON-ORNAMENTAL GRASS,
NON-ORNAMENTAL SHRUBS, SIDEWALKS, ROADWAYS, PAVEMENT OR CURBS) THAT WOULD INTERFERE
WITH THE CITY IN EXCAVATING UPON SAID EASEMENT FOR THE PURPOSES OF LAYING, CONSTRUCTING,
OPERATING, MAINTAINING OR REPAIRING WATER MAINS AND ALL APPURTENANCES INCIDENTAL
THERETO. NO CHANGE IN THE EARTH COVER OVER THE WATER LINE WILL BE MADE WITHOUT THE
WRITTEN APPROVAL OF THE DIRECTOR OF WATER SERVICES. THIS EASEMENT SHALL NOT BE
CONSTRUED TO PROHIBIT DEVELOPMENT OF ANY ADJOINING PROPERTY OR FROM THE LAYING OUT,
ESTABLISHING AND CONSTRUCTING OF ROADWAYS, SURFACING OF ROADWAYS, CURBING AND GUTTERS
ALONG, UPON, OVER OR ACROSS SAID EASEMENT OR ANY PORTION THEREOF.

SEWER EASEMENT - A SEWER EASEMENT (S.E.) FOR THE LOCATION, CONSTRUCTION, RECONSTRUCTION,
MAINTENANCE, OPERATION AND REPAIR OF SEWERAGE IMPROVEMENTS AND ANY AND ALL
APPURTENANCES INCIDENTAL THERETO IN, UNDER, UPON, OVER AND THROUGH LAND LYING, BEING
AND SITUATED IN KANSAS CITY, MISSOURI ("THE CITY") IS HEREBY GRANTED TO THE CITY. BY THE
GRANTING OF THIS EASEMENT, IT SHALL NOT BE CONSTRUED TO PROHIBIT DEVELOPMENT OF ANY
ADJOINING PROPERTY OR FROM THE LAYING OUT, ESTABLISHING AND CONSTRUCTING PAVEMENT,
SURFACING OF ROADWAYS, CURBING AND GUTTERS ALONG, UPON, OVER OR ACROSS SAID EASEMENT
OR ANY PORTION THEREOF; PROVIDED, HOWEVER, SAID EASEMENT SHALL BE KEPT FREE FROM
ADDITIONAL DEPTH OF OVERBURDEN, BUILDINGS, AND ANY OTHER STRUCTURE OR OBSTRUCTION
(EXCEPT SIDEWALKS, PAVEMENT, GRASS, SHRUBS, FENCES, OR CURBS) WHICH WILL
INTERFERE WITH THE CITY IN ENTERING UPON SAID ADJACENT LAND EASEMENT FOR THE
PURPOSE OF LAYING, CONSTRUCTING, RECONSTRUCTING, OPERATING, REPAIRING AND MAINTAINING
SUCH SEWERAGE IMPROVEMENTS AND APPURTENANCES.

FLOODPLAIN:

ACCORDING TO "FLOOD INSURANCE RATE MAP" COMMUNITY PANEL NO. 2909500035G, MAP REVISED
JANUARY 20, 2017, AS PUBLISHED BY THE FEDERAL EMERGENCY MANAGEMENT AGENCY, THIS
SUBJECT PROPERTY LINES WITH FLOOD ZONE "X" (AREAS DETERMINED TO BE OUTSIDE THE 0.2%
ANNUAL CHANCE FLOODPLAIN) AND ZONE "A" (THE 1% ANNUAL CHANCE FLOOD (100-YEAR FLOOD),
ALSO KNOWN AS THE BASE FLOOD, IS THE FLOOD THAT HAS A 1% CHANCE OF BEING EQUALLED OR
EXCEEDED IN ANY GIVEN YEAR. THE LANDS HEREIN PLATTED LIE TOTALLY OR PARTIALLY WITHIN THE
LIMITS OF THE REGULATORY FLOODPLAIN, AS DESIGNATED ON THE OFFICIAL FLOODPLAIN DOCUMENTS
AND ARE SUBJECT TO THE RESTRICTIONS OF CHAPTER 28, CODE OF ORDINANCES OF KANSAS CITY,
MISSOURI, AND ARE FURTHER SUBJECT TO THE REVISIONS OF CHAPTER X - FEDERAL INSURANCE
ADMINISTRATION, SUBCHAPTER B - NATIONAL FLOOD INSURANCE PROGRAM FOR ELIGIBILITY THEREOF.
HOWEVER, DUE TO CHANGE IN CIRCUMSTANCES, THE BOUNDARIES AS SHOWN HEREON MAY BE
MODIFIED FROM TIME TO TIME. THEREFORE, SPECIFIC INFORMATION CONCERNING THE LOCATION OF THE
FLOODPLAIN BOUNDARIES SHOULD BE ASCERTAINED AT THE PERTINENT TIME FROM THE APPROPRIATE
AUTHORITIES, THE CITY OF KANSAS CITY, MISSOURI AND THE FEDERAL EMERGENCY MANAGEMENT
AGENCY.

RIGHT OF ENTRANCE:

THE RIGHT OF ENTRANCE AND EGRESS IN TRAVEL ALONG ANY STREET OR DRIVE WITHIN THE
BOUNDARIES OF THE PROPERTY IS HEREBY GRANTED TO KANSAS CITY, MISSOURI, FOR THE PURPOSE
OF FIRE AND POLICE PROTECTION, MAINTENANCE OF WATER MAINS, SANITARY AND STORM SEWER
LINES, COLLECTION OF GARBAGE AND REFUSE AND TO THE UNITED STATES POSTAL SERVICES FOR
THE DELIVERY OF MAIL; PROVIDED, HOWEVER, SUCH RIGHT OF INGRESS AND EGRESS DOES NOT
INCLUDE ANY OBLIGATION TO CONTRIBUTE FOR ANY DAMAGE TO ANY PRIVATE STREET OR DRIVE BY
VIRTUE OF THE EXERCISE OF THE RIGHTS STATED HEREIN AND SPECIFICALLY, NEITHER KANSAS CITY,
MISSOURI NOR THE U.S. POSTAL SERVICE SHALL INCUR ANY LIABILITY BY VIRTUE OF THE EXERCISE
OF SUCH RIGHTS.

MAINTENANCE OF TRACTS:

TRACT A (42.17 ACRES) IS TO BE USED FOR STORM WATER DETENTION AND SHALL BE MAINTAINED
BY THE OWNERS OF THE LOTS, TRACTS, AND PARCELS SHOWN WITHIN THIS PLAT PURSUANT TO THE
COVENANT TO MAINTAIN STORM WATER DETENTION AND BMP FACILITIES PLAT OF KCI 29 LOGISTICS
PARK SECOND PLAT.

STREET DEDICATION: STREETS SHOWN HEREON AND NOT HERETOFORE DEDICATED FOR PUBLIC
USE AS STREET RIGHT-OF-WAY ARE HEREBY DEDICATED

STREET GRADES:

STREET GRADES FOR A PORTION OF NW 132ND STREET, NW ROANRIDGE ROAD
& N. MEXICO CITY AVENUE WERE UNAVAILABLE THROUGH A SEARCH OF CITY
ORDINANCES.

N. MEXICO CITY AVENUE

| GRADE POINT | ELEV. | DESC. | V.C.T. |
|-------------|--------|--------------------|---------|
| 152+09.93 | ---- | BEGIN CONSTRUCTION | |
| 154+75.00 | 948.93 | VPC | |
| 156+25.00 | 947.43 | VPI | 300.00' |
| 157+75.00 | 940.58 | VPT | |
| 158+75.00 | 936.00 | VPC | |
| 162+25.00 | 920.00 | VPI | 700.00' |
| 162+39.03 | 927.68 | LOW POINT STA. | |
| 165+75.00 | 934.77 | VPT | |
| 167+50.00 | 942.15 | VPC | |
| 168+50.00 | 946.37 | VPI | 200.00' |
| 169+50.00 | 947.37 | VPT | |
| 169+81.03 | ---- | END CONSTRUCTION | |

NW. 136TH STREET (N. MEXICO CITY AVENUE IMPROVEMENTS)

| GRADE POINT | ELEV. | DESC. | V.C.T. |
|-------------|--------|--------------------------------|---------|
| 650+50.03 | ---- | BEGIN CONSTRUCTION | |
| 651+75.00 | 945.24 | VPC | |
| 651+35.00 | 946.89 | VPI | 120.00' |
| 651+95.00 | 948.09 | VPT | |
| 652+98.67 | ---- | STA 153+68.42 N. MEXICO AVENUE | |
| 653+50.00 | 949.13 | VPC | |
| 654+75.00 | 947.88 | LOW POINT STATION | |
| 654+75.00 | 946.63 | VPI | 250.00' |
| 655+27.64 | ---- | END CONSTRUCTION | |

NW. 136TH STREET (NW. 136TH STREET IMPROVEMENTS)

| GRADE POINT | ELEV. | DESC. | V.C.T. |
|-------------|--------|--------------------|---------|
| 655+27.64 | ---- | BEGIN CONSTRUCTION | |
| 656+00.00 | 949.13 | VPT | |
| 660+25.00 | 957.63 | VPC | |
| 661+45.00 | 952.80 | SPECIAL DITCH RT | |
| 661+75.00 | 960.63 | VPI | 300.00' |
| 662+00.00 | 954.50 | SPECIAL DITCH LT | |
| 662+25.00 | 959.63 | HIGH POINT STATION | |
| 663+25.00 | 959.13 | VPT | |
| 663+50.00 | 958.88 | VPC | |
| 664+25.00 | 958.13 | VPI | 150.00' |
| 664+25.00 | 958.51 | LOW POINT STATION | |
| 664+25.00 | 957.26 | SPECIAL DITCH RT | |
| 664+25.00 | 957.28 | SPECIAL DITCH LT | |
| 665+00.00 | 958.88 | VPT | |
| 665+75.00 | 959.63 | VPC | |
| 666+50.00 | 960.01 | HIGH POINT STATION | |
| 666+50.00 | 960.38 | VPI | 150.00' |
| 667+25.00 | 959.63 | VPT | |
| 668+00.00 | 958.88 | VPC | |
| 669+00.00 | 958.38 | LOW POINT STATION | |
| 669+00.00 | 957.88 | VPI | 200.00' |
| 669+00.00 | 957.13 | SPECIAL DITCH RT | |
| 669+00.00 | 957.13 | SPECIAL DITCH LT | |
| 671+00.00 | 955.13 | SPECIAL DITCH RT | |
| 671+35.00 | 954.11 | SPECIAL DITCH LT | |
| 678+25.00 | 967.13 | VPC | |
| 679+25.00 | 968.13 | VPI | 200.00' |
| 680+25.00 | 967.13 | VPT | |
| 683+33.93 | ---- | END CONSTRUCTION | |

THIS PLAT AND SURVEY OF KCI 29 LOGISTICS PARK SECOND
PLAT WERE EXECUTED BY OLSSON, 1301 BURLINGTON STREET
#100, NORTH KANSAS CITY, MISSOURI 64116.

I HEREBY CERTIFY: THAT THE PLAT OF KCI 29 LOGISTICS PARK
SECOND PLAT SUBDIVISION IS BASED ON AN ACTUAL SURVEY
MADE BY ME OR UNDER MY DIRECT SUPERVISION AND THAT
SAID SURVEY MEETS OR EXCEEDS THE CURRENT MISSOURI
STANDARDS FOR PROPERTY BOUNDARY SURVEYS AS
ESTABLISHED BY THE MISSOURI BOARD FOR ARCHITECTS,
PROFESSIONAL ENGINEERS, PROFESSIONAL SURVEYORS AND
LANDSCAPE ARCHITECTS AND THE MISSOURI DEPARTMENT OF
AGRICULTURE. I FURTHER CERTIFY THAT I HAVE COMPLIED
WITH ALL STATUTES, ORDINANCES, AND REGULATIONS
GOVERNING THE PRACTICE OF SURVEYING AND PLATTING OF
SUBDIVISIONS TO THE BEST OF MY PROFESSIONAL KNOWLEDGE
AND BELIEF.

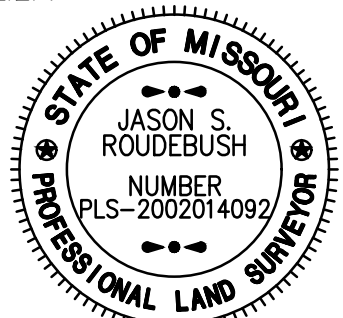

OLSSON, MO CLS 366
JASON S. ROUDEBUSH, MO PLS 2002014092
APRIL 30, 2024
J.ROUDEBUSH@OLSSON.COM

DATE OF SURVEY

| |
|--|
| 03-10-2024 - To HMW for Review |
| 03-11-2024 - 1st Submittal |
| 03-19-2024 - Title Report Request |
| 04-03-2024 - To HMW for Review |
| 04-05-2024 - 2nd Submittal |
| 04-29-2024 - Revised Plat Boundary to HMW for Review |
| 04-30-2024 - 3rd Submittal |

drawn by: NRV
surveyed by: AH-NZ-RN-TG
checked by: JPM
approved by: JSR
project no.: B21-06168
file name: V_PLAT_B2106168.DWG

Olsson
Olsson - Land Surveying - MO 366, KS 114, MO Certificate of Authority-001692
1301 Burlington Street TEL 816.361.1177
North Kansas City, MO 64116 FAX 816.361.1888 www.olsson.com

SHEET
2 of 7

FINAL PLAT OF
KCI 29 LOGISTICS PARK SECOND PLAT
 SW 1/4, SEC 3, T52N, R34W
 NE 1/4, SEC 9, T52N, R34W
 SE 1/4, NE 1/4 & NW 1/4, SEC 10, T52N, R34W
 KANSAS CITY, PLATTE COUNTY, MISSOURI

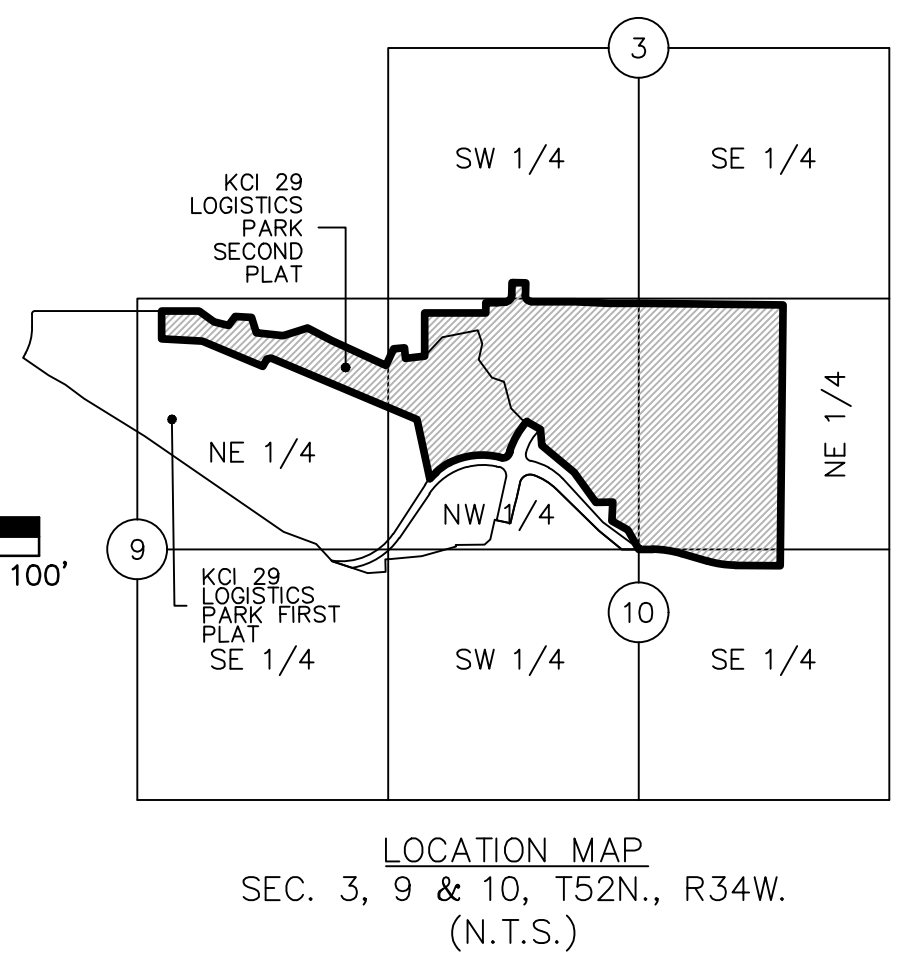

POINT OF COMMENCING
 NW COR., NE 1/4,
 NE COR., NW 1/4,
 SEC. 10, T52N, R34W
 SW COR., SE 1/4,
 SE COR., SW 1/4,
 SEC. 3, T52N, R34W

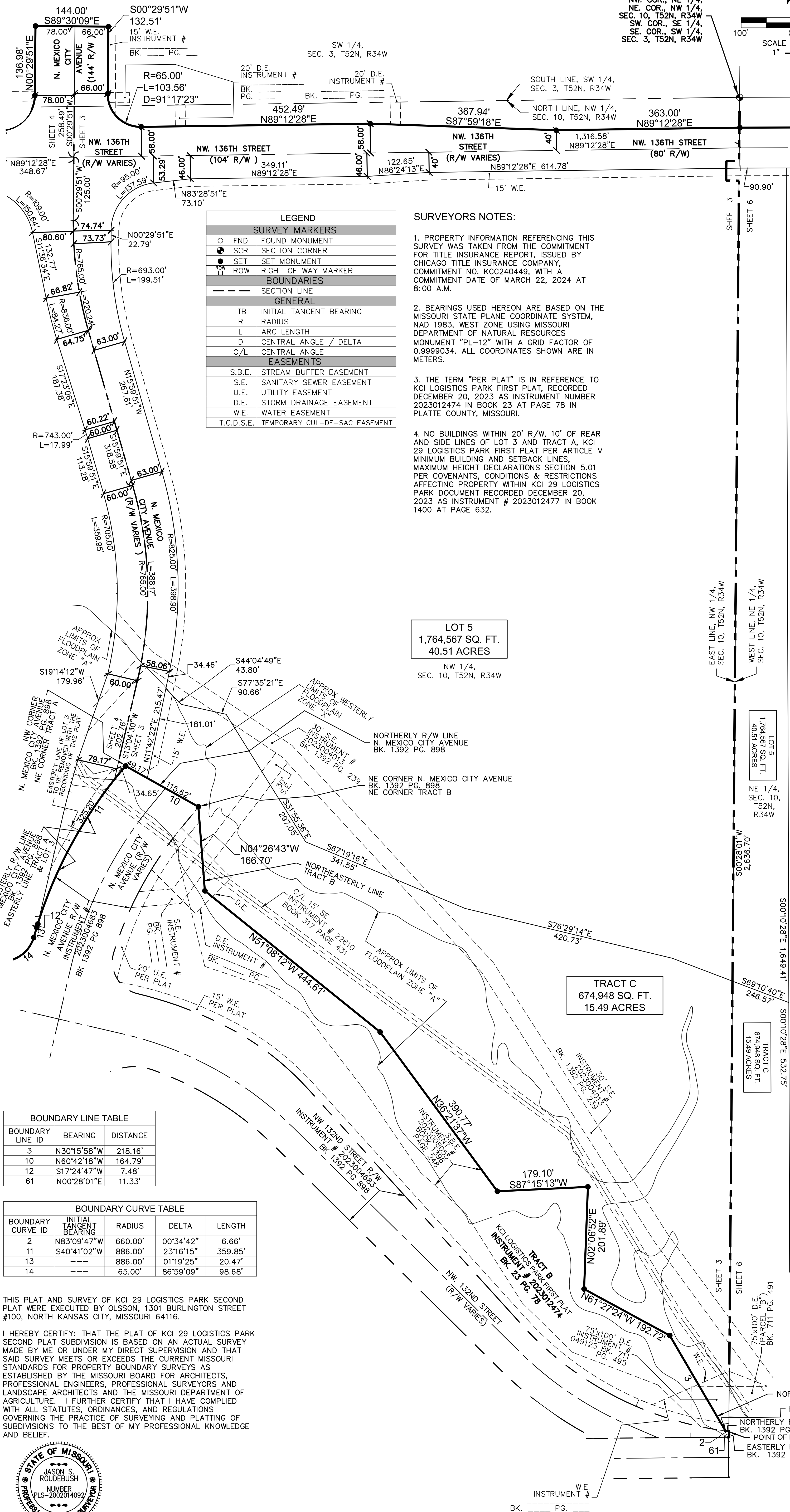
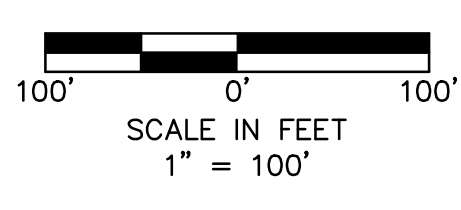

LEGEND

| SURVEY MARKERS | |
|----------------|-------------------------------|
| ○ | FND FOUND MONUMENT |
| ● | SCR SECTION CORNER |
| ⊙ | SET SET MONUMENT |
| — | ROW RIGHT OF WAY MARKER |
| BOUNDARIES | |
| --- | SECTION LINE |
| GENERAL | |
| ITB | INITIAL TANGENT BEARING |
| R | RADIUS |
| L | ARC LENGTH |
| D | CENTRAL ANGLE / DELTA |
| C/L | CENTRAL ANGLE |
| EASEMENTS | |
| S.B.E. | STREAM BUFFER EASEMENT |
| S.E. | SANITARY SEWER EASEMENT |
| U.E. | UTILITY EASEMENT |
| D.E. | STORM DRAINAGE EASEMENT |
| W.E. | WATER EASEMENT |
| T.C.D.S.E. | TEMPORARY CUL-DE-SAC EASEMENT |

SURVEYORS NOTES:

- PROPERTY INFORMATION REFERENCING THIS SURVEY WAS TAKEN FROM THE COMMITMENT FOR TITLE INSURANCE REPORT, ISSUED BY CHICAGO TITLE INSURANCE COMPANY, COMMITMENT NO. KCC240449, WITH A COMMITMENT DATE OF MARCH 22, 2024 AT 8:00 A.M.
- BEARINGS USED HEREON ARE BASED ON THE MISSOURI STATE PLANE COORDINATE SYSTEM, NAD 1983, WEST ZONE USING MISSOURI DEPARTMENT OF NATURAL RESOURCES MONUMENT "PL-12" WITH A GRID FACTOR OF 0.9999034. ALL COORDINATES SHOWN ARE IN METERS.
- THE TERM "PER PLAT" IS IN REFERENCE TO KCI LOGISTICS PARK FIRST PLAT, RECORDED DECEMBER 20, 2023 AS INSTRUMENT NUMBER 2023012474 IN BOOK 23 AT PAGE 78 IN PLATTE COUNTY, MISSOURI.
- NO BUILDINGS WITHIN 20' R/W, 10' OF REAR AND SIDE LINES OF LOT 5 AND TRACT A, KCI 29 LOGISTICS PARK FIRST PLAT PER ARTICLE V MINIMUM BUILDING AND SETBACK LINES, MAXIMUM HEIGHT DECLARATIONS SECTION 5.01 PER COVENANTS, CONDITIONS & RESTRICTIONS AFFECTING PROPERTY WITHIN KCI 29 LOGISTICS PARK DOCUMENT RECORDED DECEMBER 20, 2023 AS INSTRUMENT # 2023012477 IN BOOK 1400 AT PAGE 632.

LOT 5
 1,764,567 SQ. FT.
 40.51 ACRES

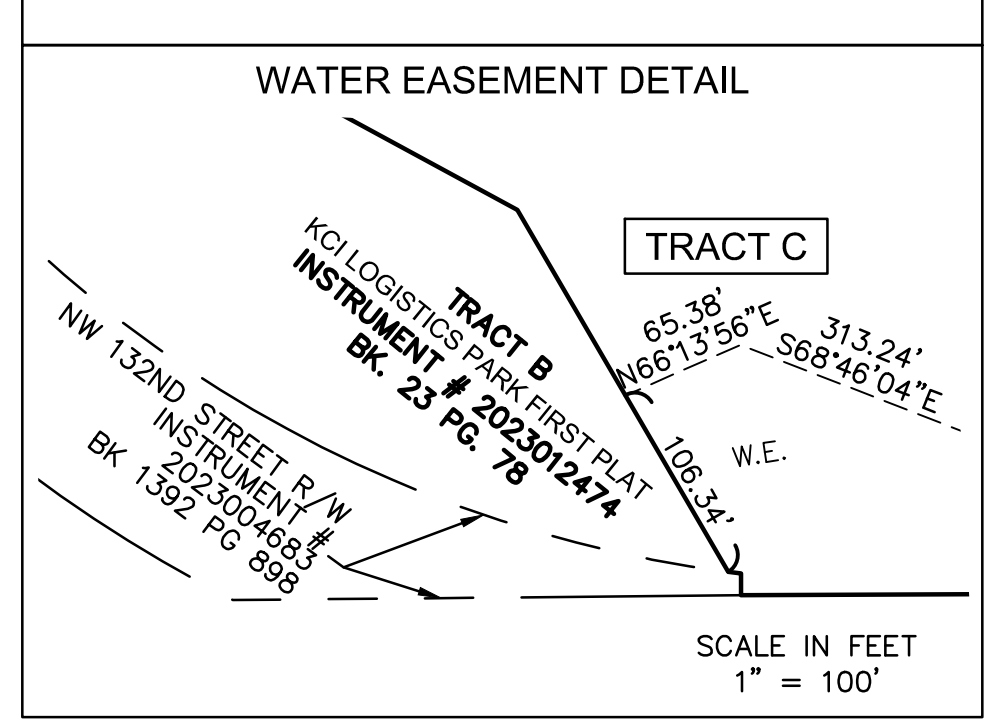
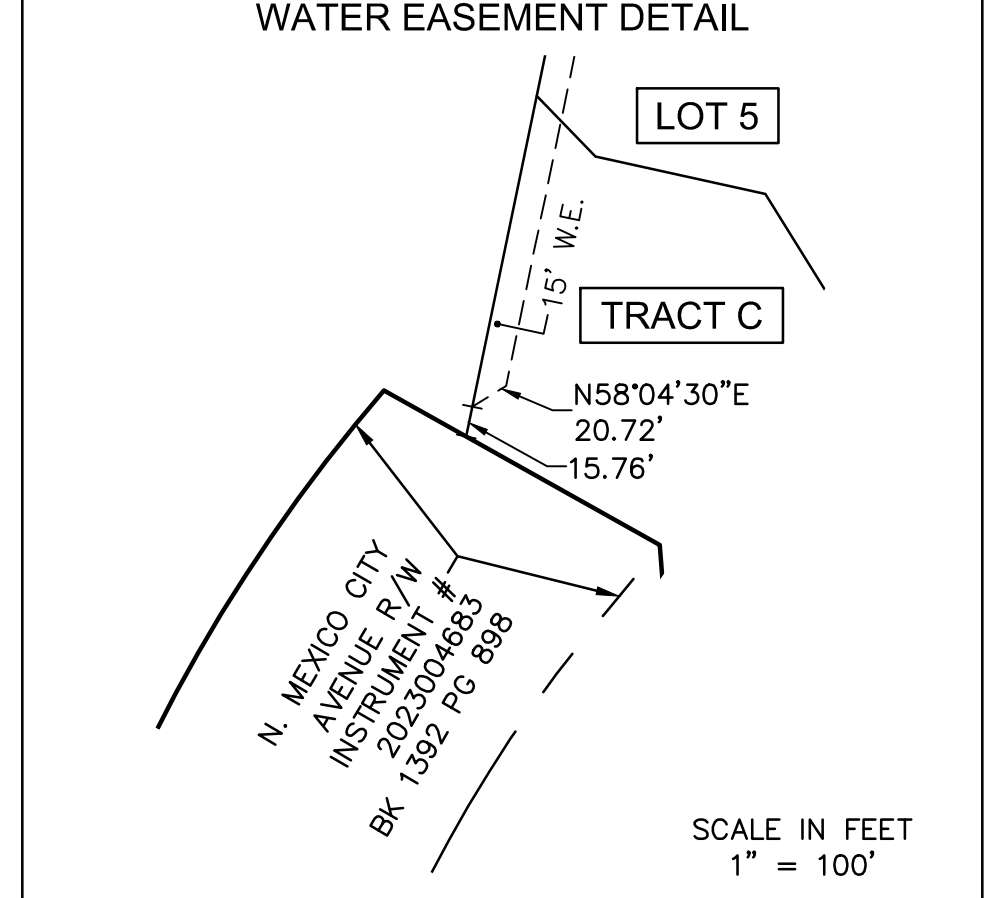
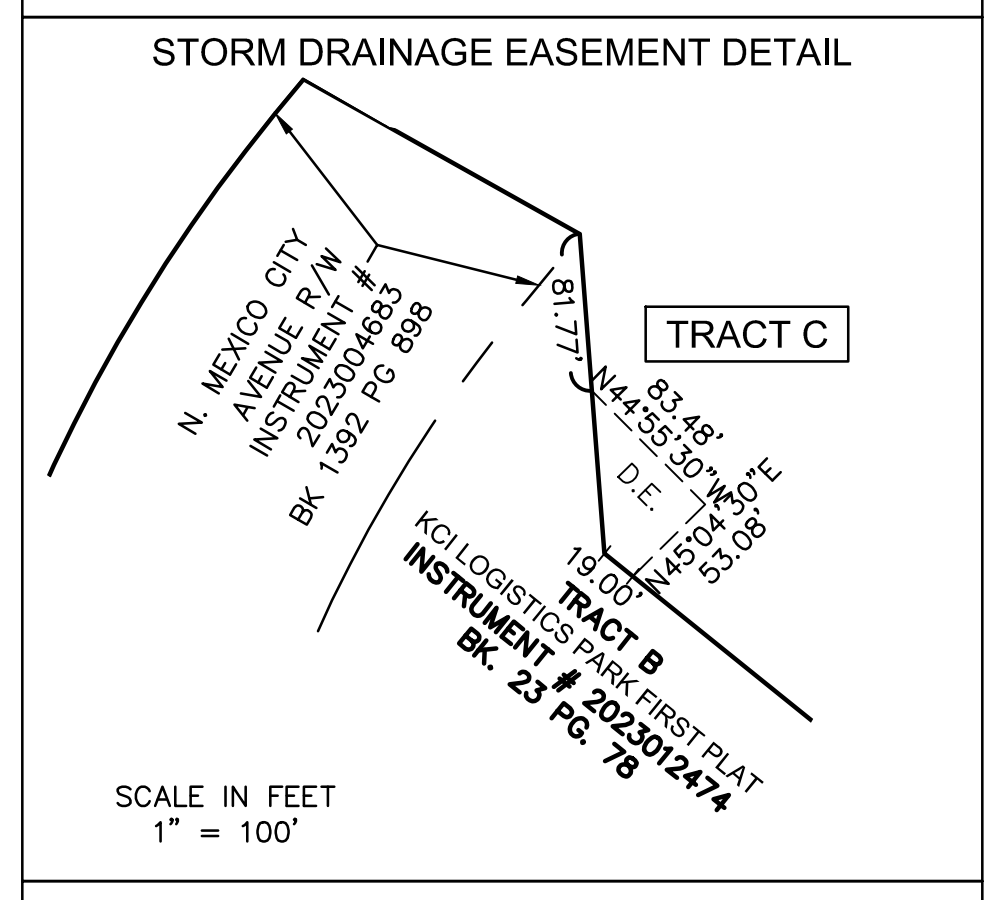
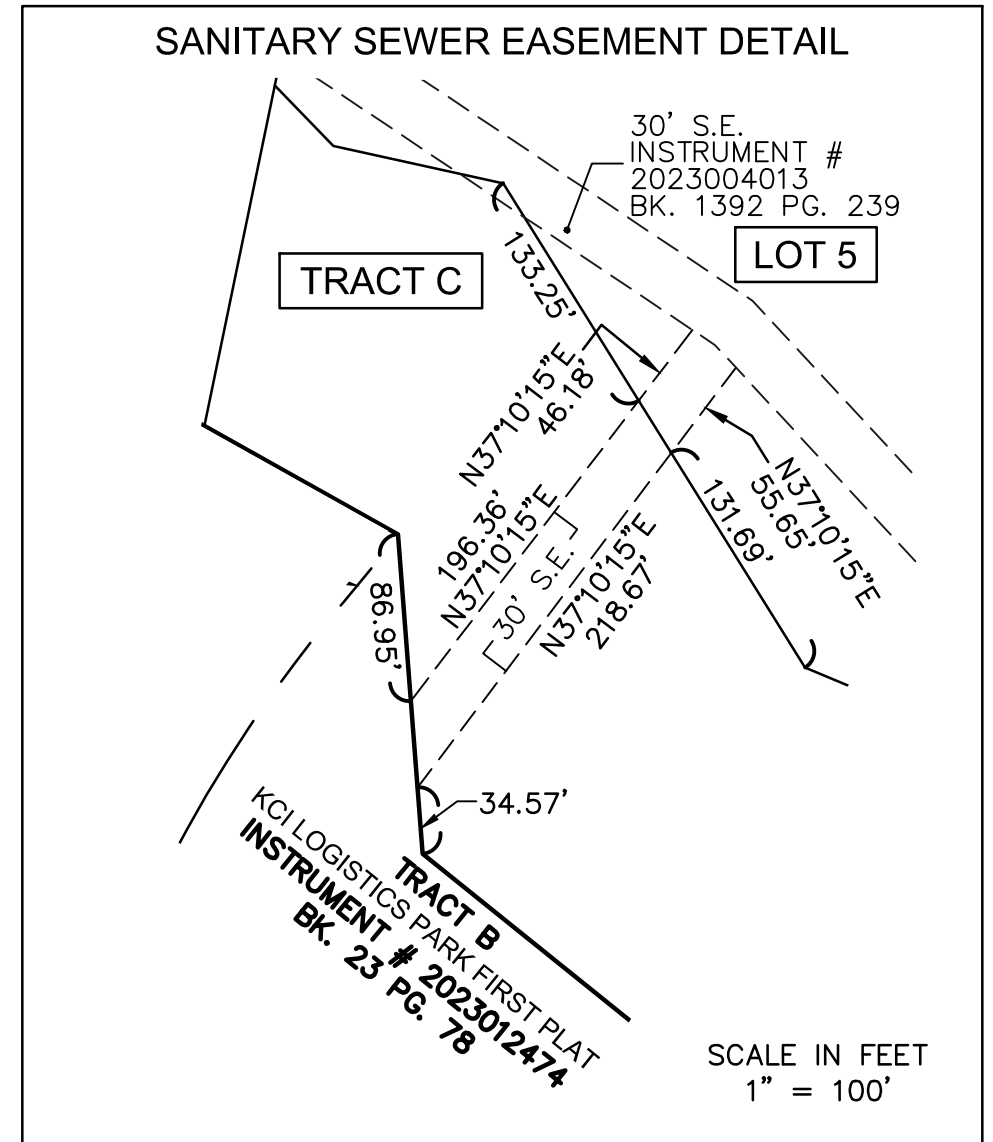

BOUNDARY LINE TABLE

| BOUNDARY LINE ID | BEARING | DISTANCE |
|------------------|-------------|----------|
| 3 | N30°15'58"W | 218.16' |
| 10 | N60°42'18"W | 164.79' |
| 12 | S17°24'47"W | 7.48' |
| 61 | N00°28'01"E | 11.33' |

BOUNDARY CURVE TABLE

| BOUNDARY CURVE ID | INITIAL TANGENT BEARING | RADIUS | DELTA | LENGTH |
|-------------------|-------------------------|---------|-----------|---------|
| 2 | N83°09'47"W | 660.00' | 00°34'42" | 6.66' |
| 11 | S40°41'02"W | 886.00' | 23°16'15" | 359.85' |
| 13 | --- | 886.00' | 01°19'25" | 20.47' |
| 14 | --- | 65.00' | 86°59'09" | 98.68' |

THIS PLAT AND SURVEY OF KCI 29 LOGISTICS PARK SECOND PLAT WERE EXECUTED BY OLSSON, 1301 BURLINGTON STREET #100, NORTH KANSAS CITY, MISSOURI 64116.

I HEREBY CERTIFY: THAT THE PLAT OF KCI 29 LOGISTICS PARK SECOND PLAT SUBDIVISION IS BASED ON AN ACTUAL SURVEY MADE BY ME OR UNDER MY DIRECT SUPERVISION AND THAT SAID SURVEY MEETS OR EXCEEDS THE CURRENT MISSOURI STANDARDS FOR PROPERTY BOUNDARY SURVEYS AS ESTABLISHED BY THE MISSOURI BOARD FOR ARCHITECTS, PROFESSIONAL ENGINEERS, PROFESSIONAL SURVEYORS AND LANDSCAPE ARCHITECTS AND THE MISSOURI DEPARTMENT OF AGRICULTURE. I FURTHER CERTIFY THAT I HAVE COMPLIED WITH ALL STATUTES, ORDINANCES AND REGULATIONS GOVERNING THE PRACTICE OF SURVEYING AND PLATTING OF SUBDIVISIONS TO THE BEST OF MY PROFESSIONAL KNOWLEDGE AND BELIEF.



OLSSON, MO CLS 366
 Jason Roudebush, MO PLS 2002014092
 APRIL 30, 2024
 JROUDEBUSH@OLSSON.COM

DEVELOPER:
 HUNT MIDWEST REAL ESTATE DEVELOPMENT, INC.
 8300 NE UNDERGROUND DRIVE
 KANSAS CITY, MO 64161
 816-455-2500

DATE OF SURVEY

| | |
|------------|---|
| 03-10-2024 | To HMW for Review |
| 03-11-2024 | 1st Submittal |
| 03-18-2024 | Title Report Request |
| 04-03-2024 | To HMW for Review |
| 04-05-2024 | 2nd Submittal |
| 04-29-2024 | Revised Plat Boundary to HMW for Review |
| 04-30-2024 | 3rd Submittal |

drawn by: NBRW
 surveyed by: AH-NZ-RN-TG
 checked by: JPM
 approved by: JSR
 project no.: B21-06168
 file name: V_PLAT_B2106168.DWG

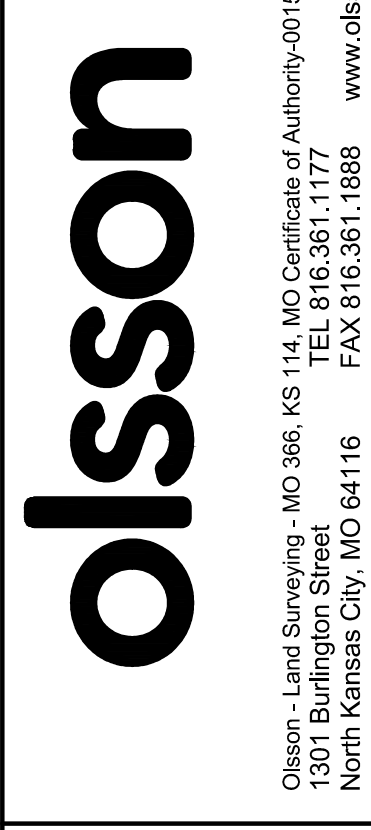

DWG: F:\2021\06001-06500\021-06168-B\40-Design\Survey\SRVY\Sheets\Plat_V_PLAT_B2106168.dwg
 USER: nwilloughby
 DATE: APR 30, 2024 6:53PM

FINAL PLAT OF
KCI 29 LOGISTICS PARK SECOND PLAT
 SW 1/4, SEC 3, T52N, R34W
 NE 1/4, SEC 9, T52N, R34W
 SE 1/4, NE 1/4 & NW 1/4, SEC 10, T52N, R34W
 KANSAS CITY, PLATTE COUNTY, MISSOURI

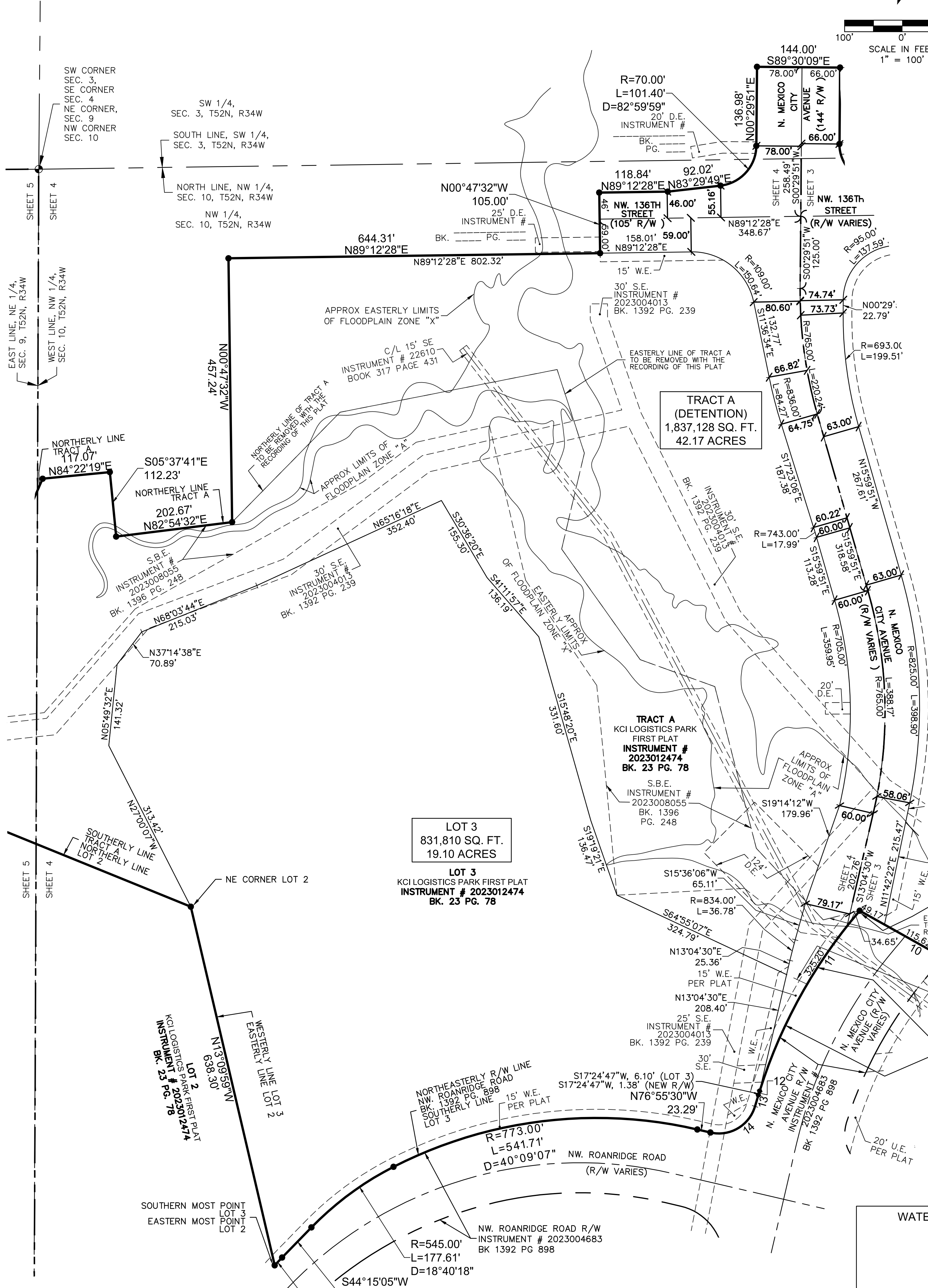
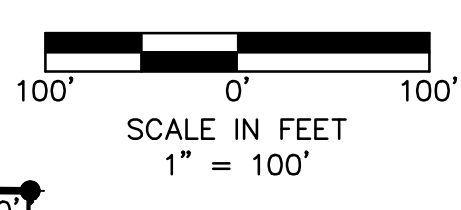
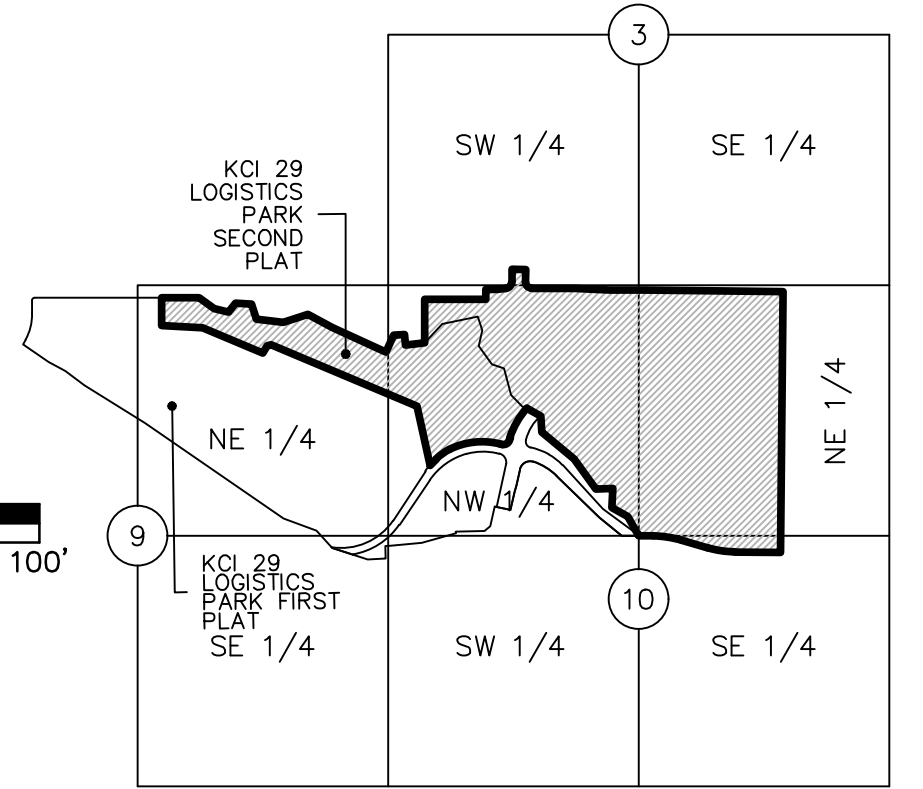

| LEGEND | |
|----------------|-------------------------------|
| SURVEY MARKERS | |
| ○ | FND FOUND MONUMENT |
| ● | SCR SECTION CORNER |
| ⊙ | SET SET MONUMENT |
| ⊕ | ROW RIGHT OF WAY MARKER |
| BOUNDARIES | |
| --- | SECTION LINE |
| GENERAL | |
| ITB | INITIAL TANGENT BEARING |
| R | RADIUS |
| L | ARC LENGTH |
| D | CENTRAL ANGLE / DELTA |
| C/L | CENTRAL ANGLE |
| EASEMENTS | |
| S.B.E. | STREAM BUFFER EASEMENT |
| S.E. | SANITARY SEWER EASEMENT |
| U.E. | UTILITY EASEMENT |
| D.E. | STORM DRAINAGE EASEMENT |
| W.E. | WATER EASEMENT |
| T.C.D.S.E. | TEMPORARY CUL-DE-SAC EASEMENT |

- SURVEYORS NOTES:**
- PROPERTY INFORMATION REFERENCING THIS SURVEY WAS TAKEN FROM THE COMMITMENT FOR TITLE INSURANCE REPORT, ISSUED BY CHICAGO TITLE INSURANCE COMPANY, COMMITMENT NO. KCC240449, WITH A COMMITMENT DATE OF MARCH 22, 2024 AT 8:00 A.M.
 - BEARINGS USED HEREON ARE BASED ON THE MISSOURI STATE PLANE COORDINATE SYSTEM, NAD 1983, WEST ZONE USING MISSOURI DEPARTMENT OF NATURAL RESOURCES MONUMENT "PL-12" WITH A GRID FACTOR OF 0.9999034. ALL COORDINATES SHOWN ARE IN METERS.
 - THE TERM "PER PLAT" IS IN REFERENCE TO KCI LOGISTICS PARK FIRST PLAT, RECORDED DECEMBER 20, 2023 AS INSTRUMENT NUMBER 2023012474 IN BOOK 23 AT PAGE 78 IN PLATTE COUNTY, MISSOURI.
 - NO BUILDINGS WITHIN 20' R/W, 10' OF REAR AND SIDE LINES OF LOT 3 AND TRACT A, KCI 29 LOGISTICS PARK FIRST PLAT PER ARTICLE V MINIMUM BUILDING AND SETBACK LINES, MAXIMUM HEIGHT DECLARATIONS SECTION 5.01 PER COVENANTS, CONDITIONS & RESTRICTIONS AFFECTING PROPERTY WITHIN KCI 29 LOGISTICS PARK DOCUMENT RECORDED DECEMBER 20, 2023 AS INSTRUMENT # 2023012477 IN BOOK 1400 AT PAGE 632.

DEVELOPER:
 HUNT MIDWEST REAL ESTATE DEVELOPMENT, INC.
 8300 NE UNDERGROUND DRIVE
 KANSAS CITY, MO 64161
 816-455-2500

| BOUNDARY LINE ID | BEARING | DISTANCE |
|------------------|-------------|----------|
| 10 | N60°42'18"W | 164.79' |
| 12 | S17°24'47"W | 7.48' |

| BOUNDARY CURVE ID | INITIAL TANGENT BEARING | RADIUS | DELTA | LENGTH |
|-------------------|-------------------------|---------|-----------|---------|
| 11 | S40°41'02"W | 886.00' | 23°16'15" | 359.85' |
| 13 | --- | 886.00' | 01°19'25" | 20.47' |
| 14 | --- | 65.00' | 86°59'09" | 98.68' |

THIS PLAT AND SURVEY OF KCI 29 LOGISTICS PARK SECOND PLAT SUBDIVISION IS BASED ON AN ACTUAL SURVEY MADE BY ME OR UNDER MY DIRECT SUPERVISION AND THAT SAID SURVEY MEETS OR EXCEEDS THE CURRENT MISSOURI STANDARDS FOR PROPERTY BOUNDARY SURVEYS AS ESTABLISHED BY THE MISSOURI BOARD FOR ARCHITECTS, PROFESSIONAL ENGINEERS, PROFESSIONAL SURVEYORS AND LANDSCAPE ARCHITECTS AND THE MISSOURI DEPARTMENT OF AGRICULTURE. I FURTHER CERTIFY THAT I HAVE COMPLIED WITH ALL STATUTES, ORDINANCES, AND REGULATIONS GOVERNING THE PRACTICE OF SURVEYING AND PLATTING OF SUBDIVISIONS TO THE BEST OF MY PROFESSIONAL KNOWLEDGE AND BELIEF.

I HEREBY CERTIFY: THAT THE PLAT OF KCI 29 LOGISTICS PARK SECOND PLAT SUBDIVISION IS BASED ON AN ACTUAL SURVEY MADE BY ME OR UNDER MY DIRECT SUPERVISION AND THAT SAID SURVEY MEETS OR EXCEEDS THE CURRENT MISSOURI STANDARDS FOR PROPERTY BOUNDARY SURVEYS AS ESTABLISHED BY THE MISSOURI BOARD FOR ARCHITECTS, PROFESSIONAL ENGINEERS, PROFESSIONAL SURVEYORS AND LANDSCAPE ARCHITECTS AND THE MISSOURI DEPARTMENT OF AGRICULTURE. I FURTHER CERTIFY THAT I HAVE COMPLIED WITH ALL STATUTES, ORDINANCES, AND REGULATIONS GOVERNING THE PRACTICE OF SURVEYING AND PLATTING OF SUBDIVISIONS TO THE BEST OF MY PROFESSIONAL KNOWLEDGE AND BELIEF.



OLSSON, MO CLS 366
 Jason Roudebush, MO PLS 2002014092
 APRIL 30, 2024
 JROUDEBUSH@OLSSON.COM

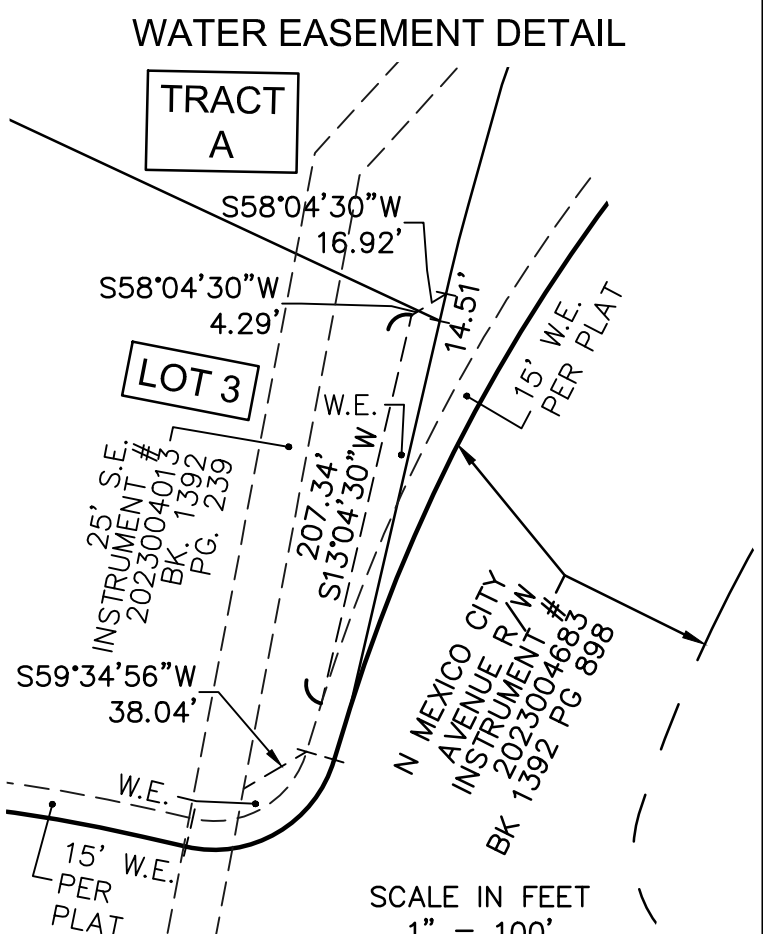
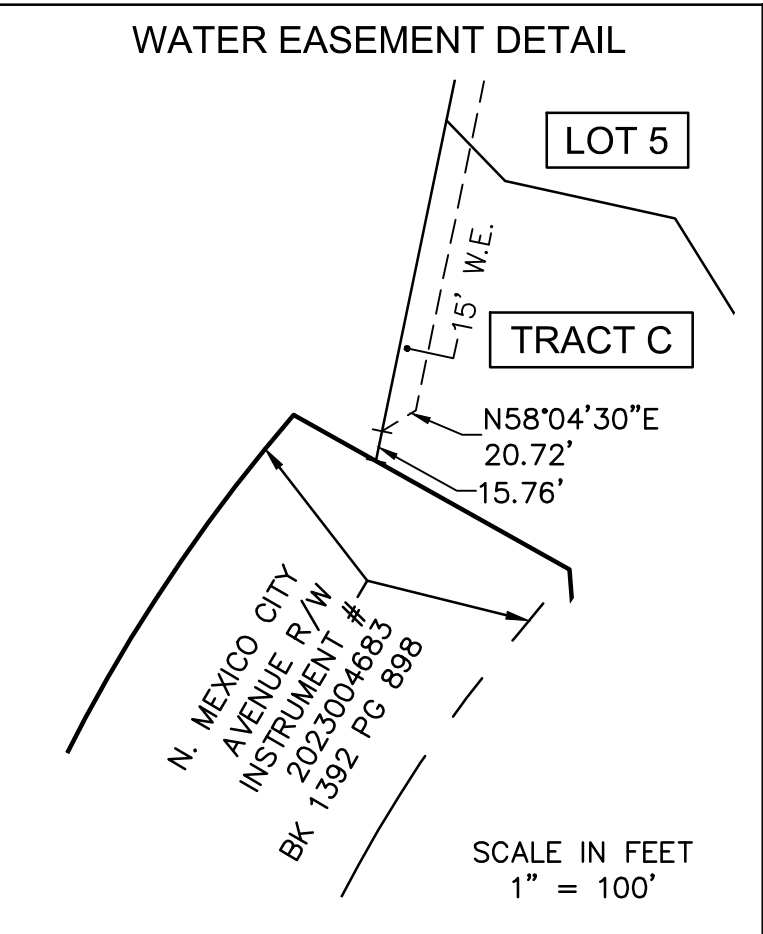
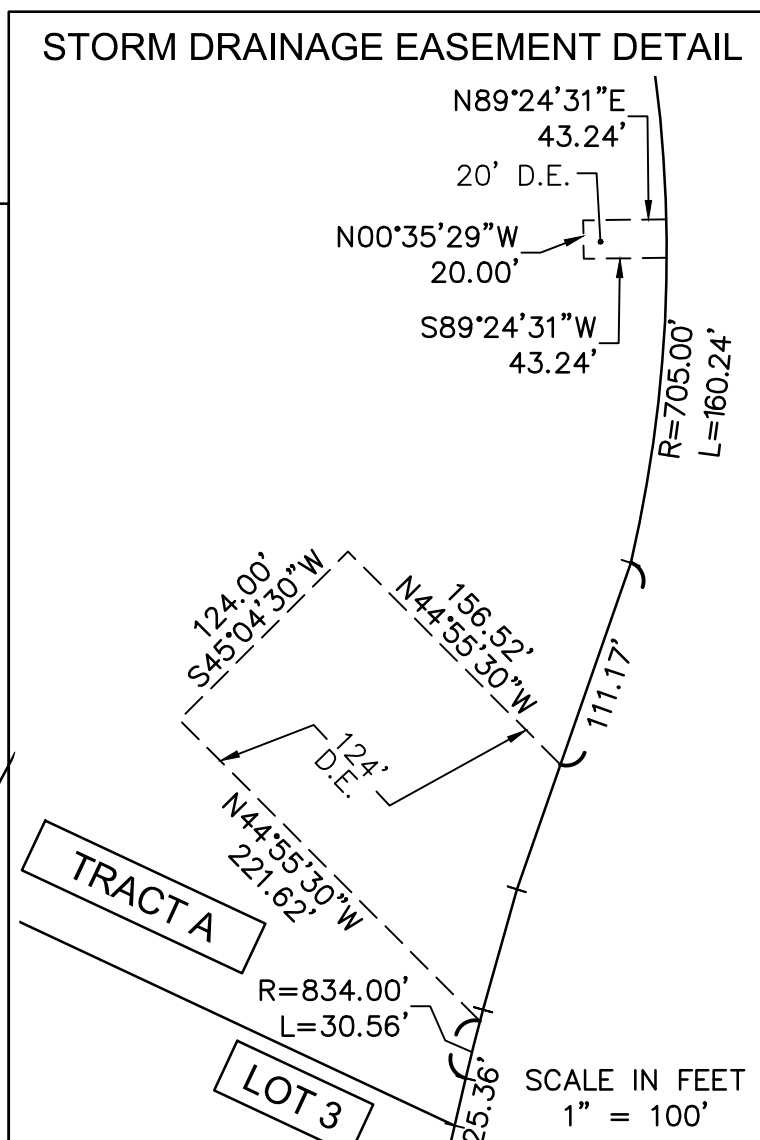
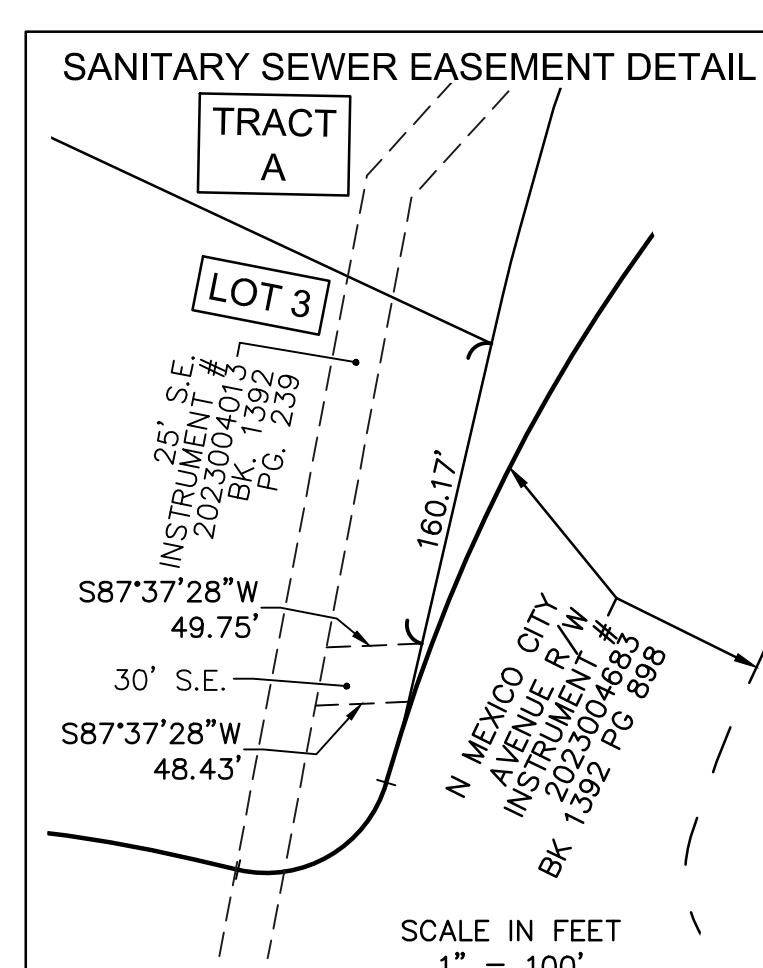

| | |
|------------|---|
| 03-10-2024 | - To HMW for Review |
| 03-11-2024 | - 1st Submittal |
| 03-18-2024 | - Title Report Request |
| 04-03-2024 | - To HMW for Review |
| 04-05-2024 | - 2nd Submittal |
| 04-29-2024 | - Revised Plat Boundary to HMW for Review |
| 04-30-2024 | - 3rd Submittal |

drawn by: NBRW
 surveyed by: AH-NZ-RN-TG
 checked by: JPM
 approved by: JSR
 project no.: B21-06168
 file name: V_PLAT_B2106168.DWG

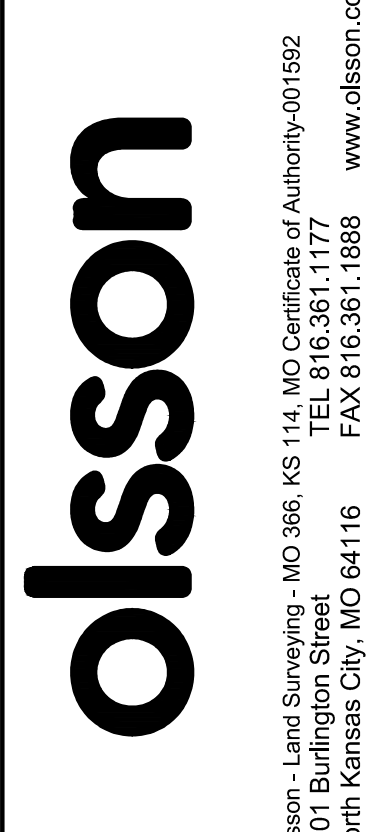

USER: nwilloughby

DWG: F:\2021\06001-06500\021-06168-B\40-Design\Survey\SRV\Sheets\Plat_V_PLAT_B2106168.dwg
 DATE: Apr 30, 2024 6:54PM

FINAL PLAT OF
KCI 29 LOGISTICS PARK SECOND PLAT
 SW 1/4, SEC 3, T52N, R34W
 NE 1/4, SEC 9, T52N, R34W
 SE 1/4, NE 1/4 & NW 1/4, SEC 10, T52N, R34W
 KANSAS CITY, PLATTE COUNTY, MISSOURI

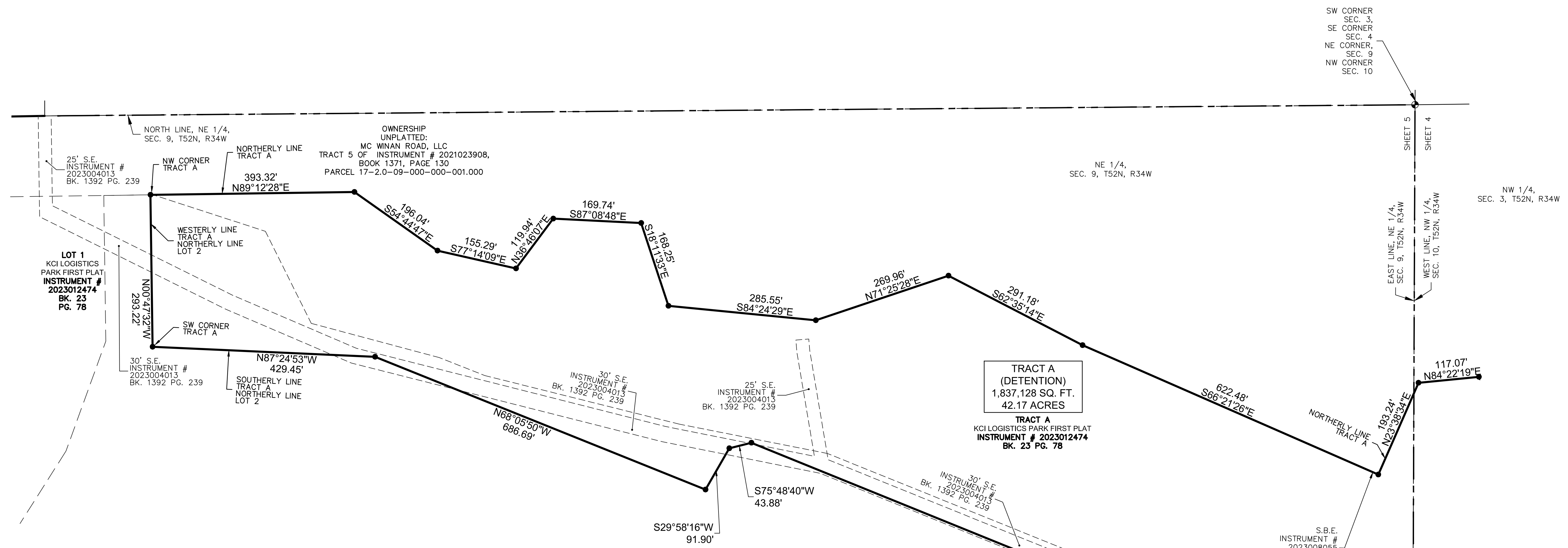
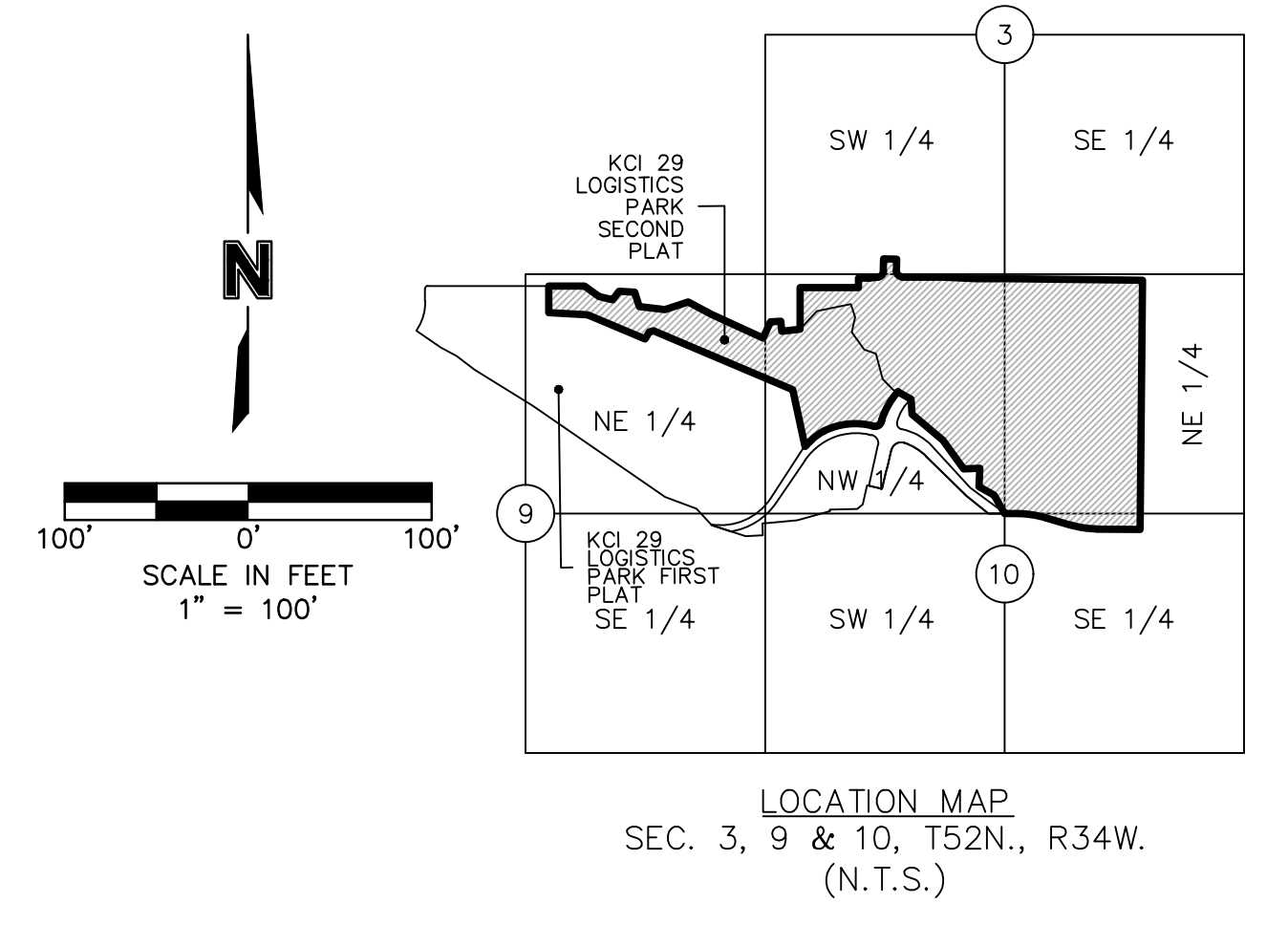

THIS PLAT AND SURVEY OF KCI 29 LOGISTICS PARK SECOND PLAT WERE EXECUTED BY OLSSON, 1301 BURLINGTON STREET #100, NORTH KANSAS CITY, MISSOURI 64116.

I HEREBY CERTIFY: THAT THE PLAT OF KCI 29 LOGISTICS PARK SECOND PLAT SUBDIVISION IS BASED ON AN ACTUAL SURVEY MADE BY ME OR UNDER MY DIRECT SUPERVISION AND THAT SAID SURVEY MEETS OR EXCEEDS THE CURRENT MISSOURI STANDARDS FOR PROPERTY BOUNDARY SURVEYS AS ESTABLISHED BY THE MISSOURI BOARD FOR ARCHITECTS, PROFESSIONAL ENGINEERS, PROFESSIONAL SURVEYORS AND LANDSCAPE ARCHITECTS AND THE MISSOURI DEPARTMENT OF AGRICULTURE. I FURTHER CERTIFY THAT I HAVE COMPLIED WITH ALL STATUTES, ORDINANCES, AND REGULATIONS GOVERNING THE PRACTICE OF SURVEYING AND PLATTING OF SUBDIVISIONS TO THE BEST OF MY PROFESSIONAL KNOWLEDGE AND BELIEF.

SURVEYORS NOTES:

- PROPERTY INFORMATION REFERENCING THIS SURVEY WAS TAKEN FROM THE COMMITMENT FOR TITLE INSURANCE REPORT, ISSUED BY CHICAGO TITLE INSURANCE COMPANY, COMMITMENT NO. KCC240449, WITH A COMMITMENT DATE OF MARCH 22, 2024 AT 8:00 A.M.
- BEARINGS USED HEREON ARE BASED ON THE MISSOURI STATE PLANE COORDINATE SYSTEM, NAD 1983, WEST ZONE USING MISSOURI DEPARTMENT OF NATURAL RESOURCES MONUMENT "PL-12" WITH A GRID FACTOR OF 0.9999034. ALL COORDINATES SHOWN ARE IN METERS.
- THE TERM "PER PLAT" IS IN REFERENCE TO KCI LOGISTICS PARK FIRST PLAT, RECORDED DECEMBER 20, 2023 AS INSTRUMENT NUMBER 2023012474 IN BOOK 23 AT PAGE 78 IN PLATTE COUNTY, MISSOURI.
- NO BUILDINGS WITHIN 20' R/W, 10' OF REAR AND SIDE LINES OF LOT 3 AND TRACT A, KCI 29 LOGISTICS PARK FIRST PLAT PER ARTICLE V MINIMUM BUILDING AND SETBACK LINES, MAXIMUM HEIGHT DECLARATIONS SECTION 5.01 PER COVENANTS, CONDITIONS & RESTRICTIONS AFFECTING PROPERTY WITHIN KCI 29 LOGISTICS PARK DOCUMENT RECORDED DECEMBER 20, 2023 AS INSTRUMENT # 2023012477 IN BOOK 1400 AT PAGE 632.

| LEGEND | |
|----------------|-------------------------------|
| SURVEY MARKERS | |
| ○ FND | FOUND MONUMENT |
| ⊙ SCR | SECTION CORNER |
| ● SET | SET MONUMENT |
| ROW | RIGHT OF WAY MARKER |
| BOUNDARIES | |
| --- | SECTION LINE |
| GENERAL | |
| ITB | INITIAL TANGENT BEARING |
| R | RADIUS |
| L | ARC LENGTH |
| D | CENTRAL ANGLE / DELTA |
| C/L | CENTRAL ANGLE |
| EASEMENTS | |
| S.B.E. | STREAM BUFFER EASEMENT |
| S.E. | SANITARY SEWER EASEMENT |
| U.E. | UTILITY EASEMENT |
| D.E. | STORM DRAINAGE EASEMENT |
| W.E. | WATER EASEMENT |
| T.C.D.S.E. | TEMPORARY CUL-DE-SAC EASEMENT |



OLSSON, MO OLS 366
 Jason Roudsbush, MO PLS 2002014092
 APRIL 30, 2024
 JROUDBUSH@OLSSON.COM

| DATE OF SURVEY | |
|----------------|---|
| 03-10-2024 | To HMW for Review |
| 03-11-2024 | 1st Submittal |
| 03-18-2024 | Title Report Request |
| 04-03-2024 | To HMW for Review |
| 04-05-2024 | 2nd Submittal |
| 04-29-2024 | Revised Plat Boundary to HMW for Review |
| 04-30-2024 | 3rd Submittal |

drawn by: NRW
 surveyed by: AH-NZ-RN-TG
 checked by: JPM
 approved by: JSR
 project no.: B21-06168
 file name: V_PPLAT_B2106168.DWG

olsson
 Olsson, Inc. Surveying, MO 366, KS 114, MO Certificate of Authority-001592
 1301 Burlington Street, Kansas City, MO 64116
 TEL 816.361.1177 FAX 816.361.1888
 www.olsson.com

DEVELOPER:
 HUNT MIDWEST REAL ESTATE DEVELOPMENT, INC.
 8300 NE UNDERGROUND DRIVE
 KANSAS CITY, MO 64161
 816-455-2500

DWG: F:\2021\06001-06500\021-06168-B\40-Design\Survey\SRVY\Sheets\Plot\V_PPLAT_B2106168.dwg USER: nwilloughby DATE: Apr 30, 2024 6:55pm

FINAL PLAT OF
KCI 29 LOGISTICS PARK SECOND PLAT
 SW 1/4, SEC 3, T52N, R34W
 NE 1/4, SEC 9, T52N, R34W
 SE 1/4, NE 1/4 & NW 1/4, SEC 10, T52N, R34W
 KANSAS CITY, PLATTE COUNTY, MISSOURI

POINT OF COMMENCING
 NW COR., NE 1/4,
 NE COR., NW 1/4,
 SEC. 10, T52N, R34W
 SW COR., SE 1/4,
 SE COR., SW 1/4,
 SEC. 3, T52N, R34W

SOUTH LINE, WEST 1/2, SE 1/4,
 SEC. 3, T52N, R34W

SE CORNER WEST 1/2
 SW CORNER EAST 1/2
 SE 1/4, SEC. 3, T52N, R34W

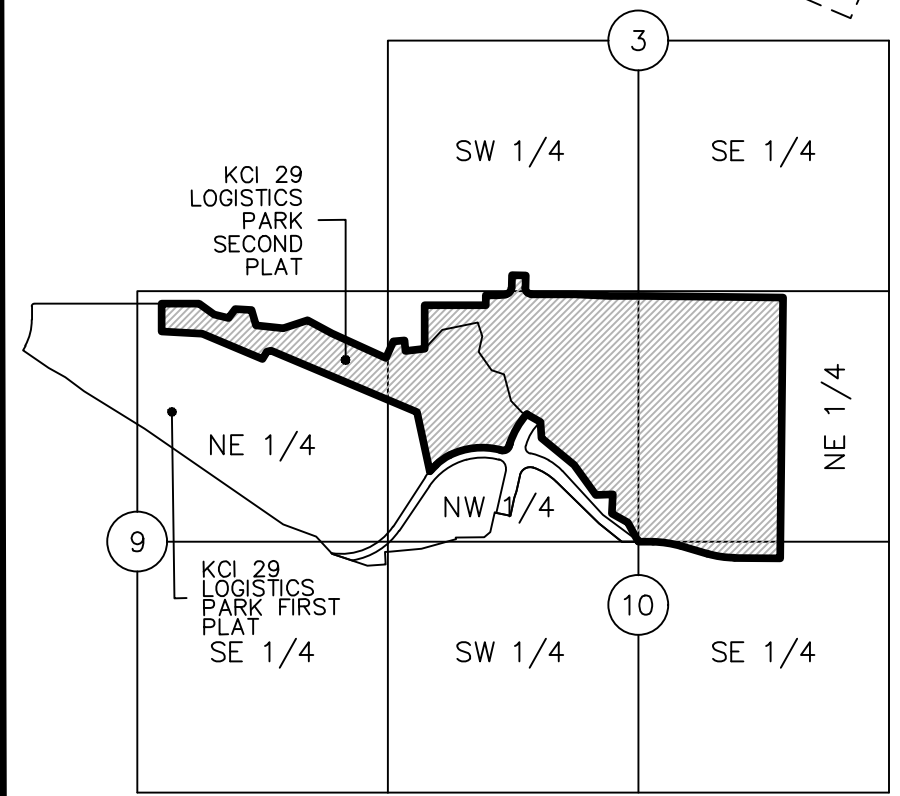
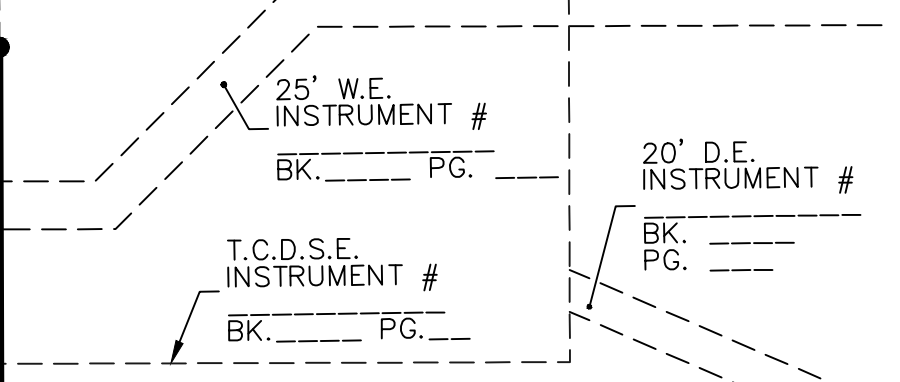
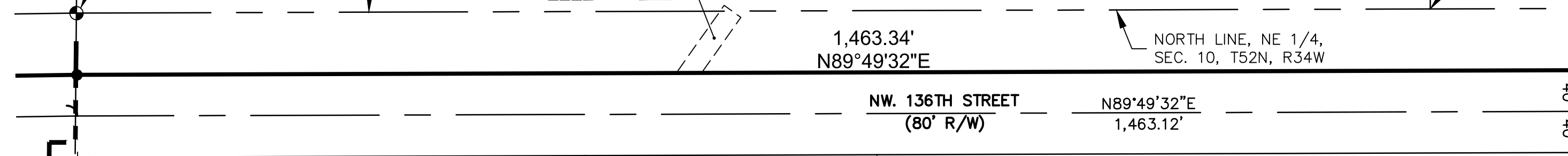

LOCATION MAP
 SEC. 3, 9 & 10, T52N., R34W.
 (N.T.S.)

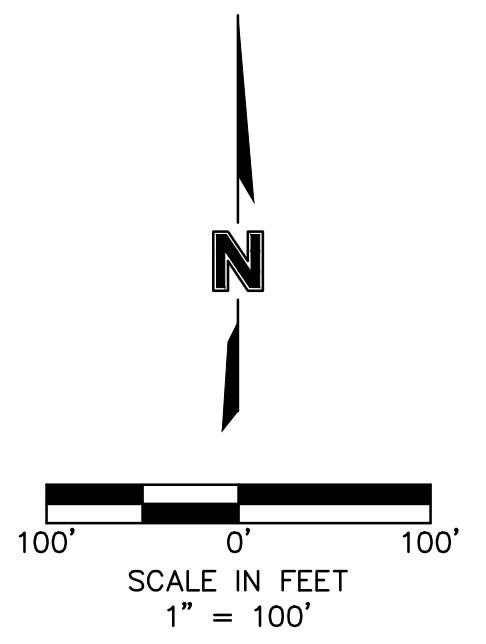

| LEGEND | |
|----------------|-------------------------------|
| SURVEY MARKERS | |
| ○ FND | FOUND MONUMENT |
| ● SCR | SECTION CORNER |
| ● SET | SET MONUMENT |
| □ ROW | RIGHT OF WAY MARKER |
| BOUNDARIES | |
| --- | SECTION LINE |
| GENERAL | |
| ITB | INITIAL TANGENT BEARING |
| R | RADIUS |
| L | ARC LENGTH |
| D | CENTRAL ANGLE / DELTA |
| C/L | CENTRAL ANGLE |
| EASEMENTS | |
| S.B.E. | STREAM BUFFER EASEMENT |
| S.E. | SANITARY SEWER EASEMENT |
| U.E. | UTILITY EASEMENT |
| D.E. | STORM DRAINAGE EASEMENT |
| W.E. | WATER EASEMENT |
| T.C.D.S.E. | TEMPORARY CUL-DE-SAC EASEMENT |

SURVEYORS NOTES:

- PROPERTY INFORMATION REFERENCING THIS SURVEY WAS TAKEN FROM THE COMMITMENT FOR TITLE INSURANCE REPORT, ISSUED BY CHICAGO TITLE INSURANCE COMPANY, COMMITMENT NO. KCC240449, WITH A COMMITMENT DATE OF MARCH 22, 2024 AT 8:00 A.M.
- BEARINGS USED HEREON ARE BASED ON THE MISSOURI STATE PLANE COORDINATE SYSTEM, NAD 1983, WEST ZONE USING MISSOURI DEPARTMENT OF NATURAL RESOURCES MONUMENT "PL-12" WITH A GRID FACTOR OF 0.9999034. ALL COORDINATES SHOWN ARE IN METERS.
- THE TERM "PER PLAT" IS IN REFERENCE TO KCI LOGISTICS PARK FIRST PLAT, RECORDED DECEMBER 20, 2023 AS INSTRUMENT NUMBER 2023012474 IN BOOK 23 AT PAGE 78 IN PLATTE COUNTY, MISSOURI.
- NO BUILDINGS WITHIN 20' R/W, 10' OF REAR AND SIDE LINES OF LOT 3 AND TRACT A, KCI 29 LOGISTICS PARK FIRST PLAT PER ARTICLE V MINIMUM BUILDING AND SETBACK LINES, MAXIMUM HEIGHT DECLARATIONS SECTION 5.01 PER COVENANTS, CONDITIONS & RESTRICTIONS AFFECTING PROPERTY WITHIN KCI 29 LOGISTICS PARK DOCUMENT RECORDED DECEMBER 20, 2023 AS INSTRUMENT # 2023012477 IN BOOK 1400 AT PAGE 632.

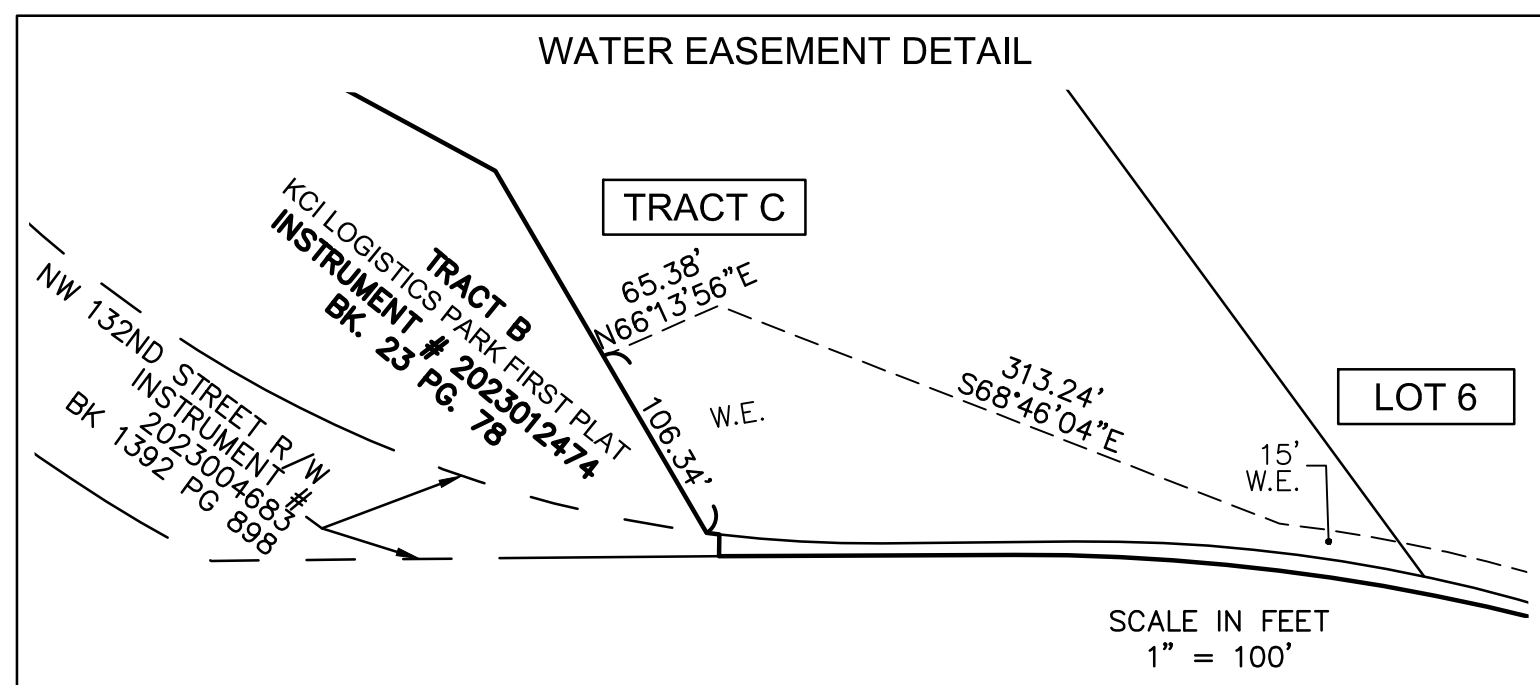
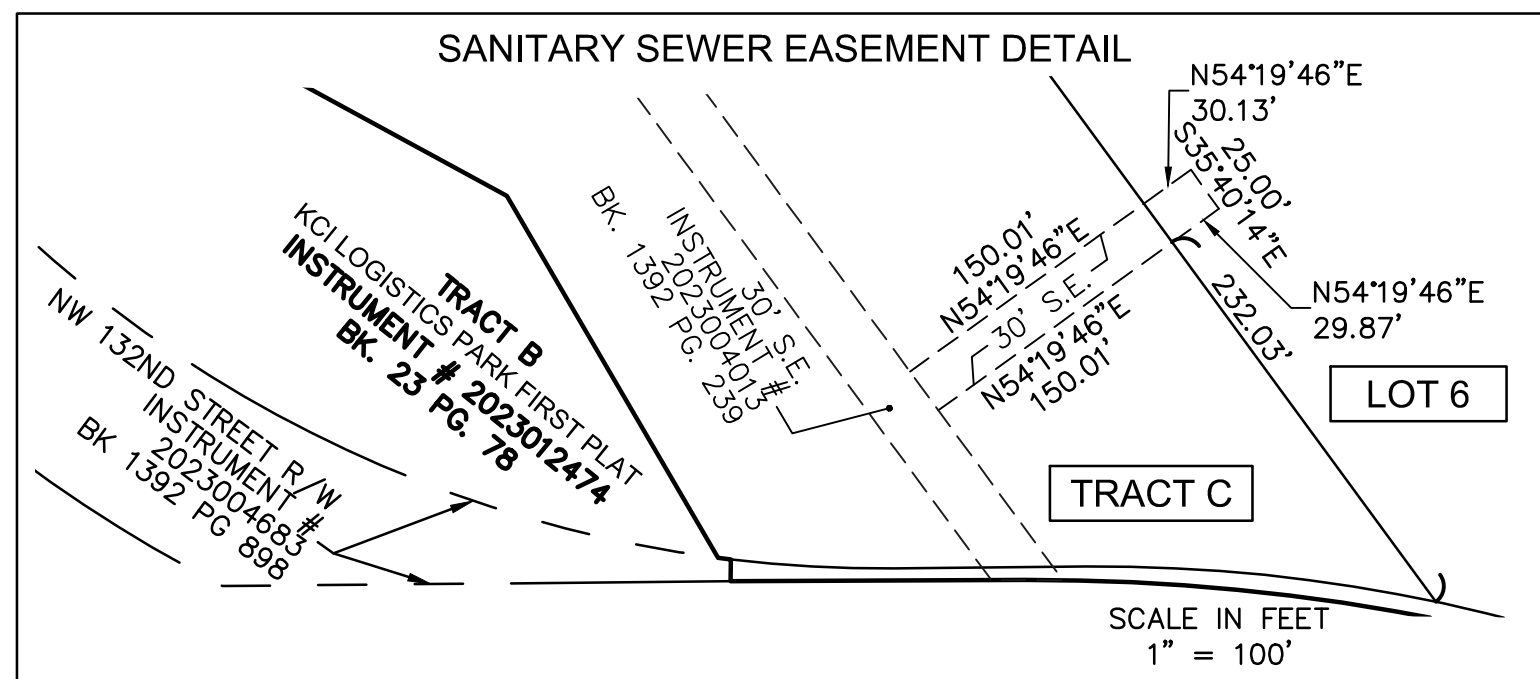

LOT 5
 1,764,667 SQ. FT.
 40.51 ACRES

TRACT C
 674,968 SQ. FT.
 15.49 ACRES

LOT 6
 3,543,230 SQ. FT.
 81.34 ACRES
 NE 1/4,
 SEC. 10, T52N, R34W

2,746.35'
 S00°10'28"E

2,666.33'

USER: nwilloughby

DWG: F:\2021\06001-06500\021-06168-B\40-Design\Survey\SRV\Sheets\Plat\PLAT_B2106168.dwg
 DATE: Apr 30, 2024 6:57PM

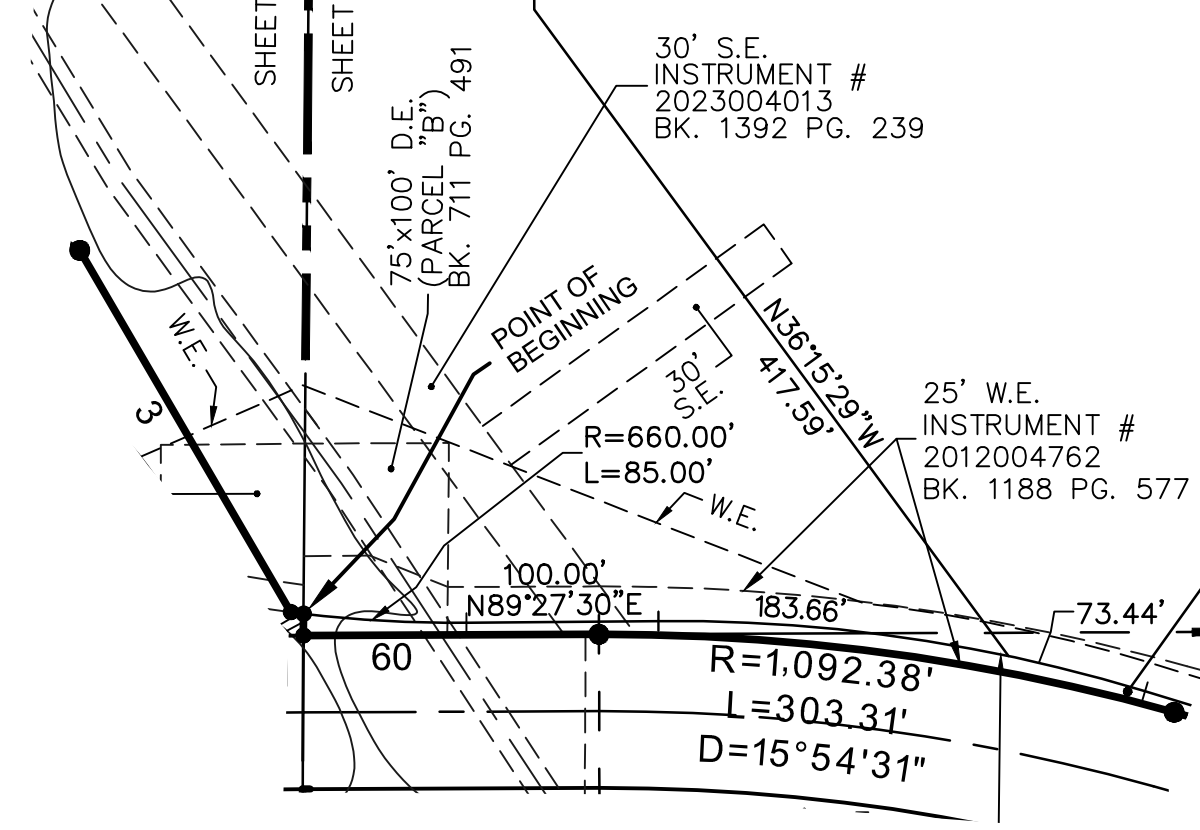

ADDITIONAL R/W BEING DEDICATED FOR NW 132ND STREET

| BOUNDARY LINE TABLE | | |
|---------------------|-------------|----------|
| BOUNDARY LINE ID | BEARING | DISTANCE |
| 3 | N30°15'58"W | 218.16' |
| 60 | S89°46'03"W | 153.89' |

DEVELOPER:
 HUNT MIDWEST REAL ESTATE DEVELOPMENT, INC.
 8300 NE UNDERGROUND DRIVE
 KANSAS CITY, MO 64111
 816-455-2500



OLSSON, MO CLS 366
 Jason Roudebush, MO PLS 2002014092
 APRIL 30, 2024
 JROUDEBUSH@OLSSON.COM

| DATE OF SURVEY | |
|----------------|---|
| 03-10-2024 | To HMW for Review |
| 03-11-2024 | 1st Submittal |
| 03-18-2024 | Title Report Request |
| 04-03-2024 | To HMW for Review |
| 04-05-2024 | 2nd Submittal |
| 04-29-2024 | Revised Plat Boundary to HMW for Review |
| 04-30-2024 | 3rd Submittal |

drawn by: NRW
 surveyed by: AH-NZ-RN-TG
 checked by: JPM
 approved by: JSR
 project no.: B21-06168
 file name: V_PLAT_B2106168.DWG

olsson
 Olsson - Land Surveyors - MO 366, KS 114, MO Certificate of Authority-001592
 1301 Burlington Street TEL 816.361.1177 www.olsson.com
 North Kansas City, MO 64116 FAX 816.361.1888

SHEET
 6 of 7

FINAL PLAT OF
KCI 29 LOGISTICS PARK SECOND PLAT
 SW 1/4, SEC 3, T52N, R34W
 NE 1/4, SEC 9, T52N, R34W
 SE 1/4, NE 1/4 & NW 1/4, SEC 10, T52N, R34W
 KANSAS CITY, PLATTE COUNTY, MISSOURI

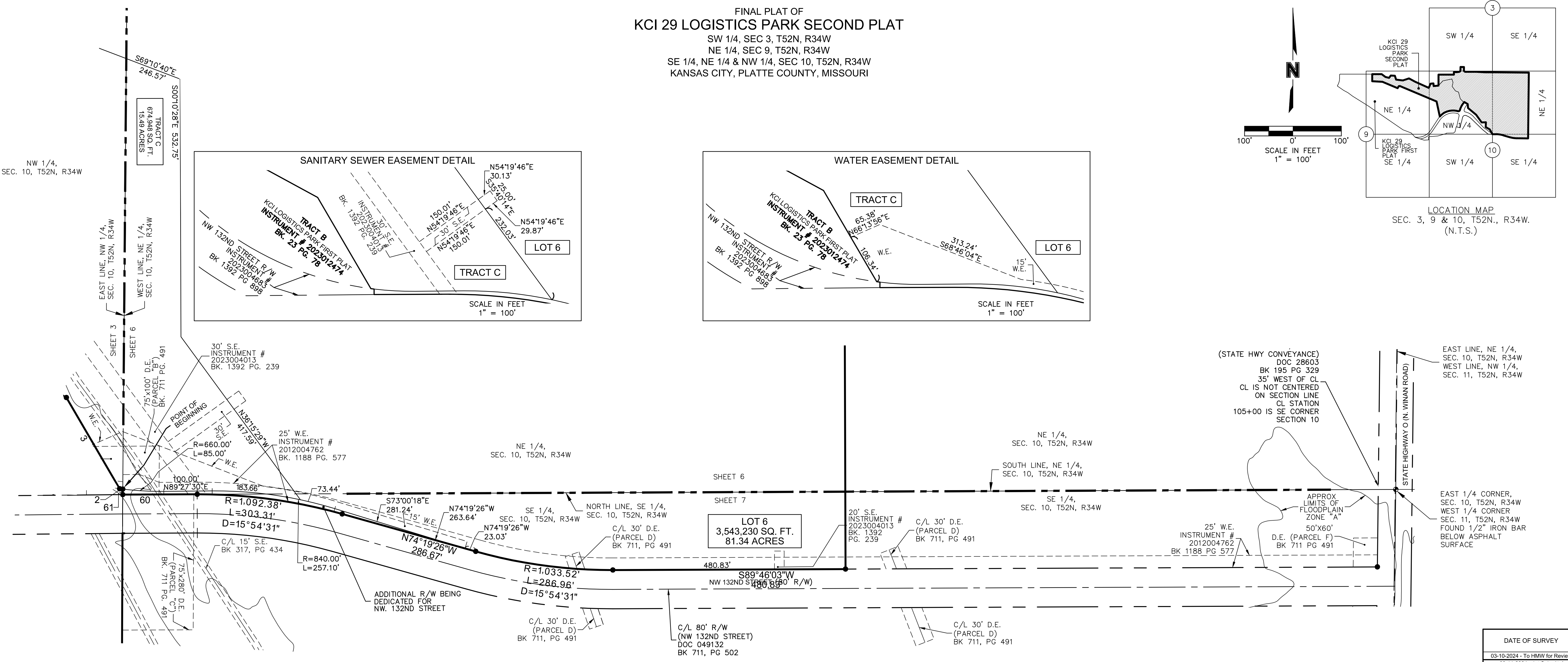
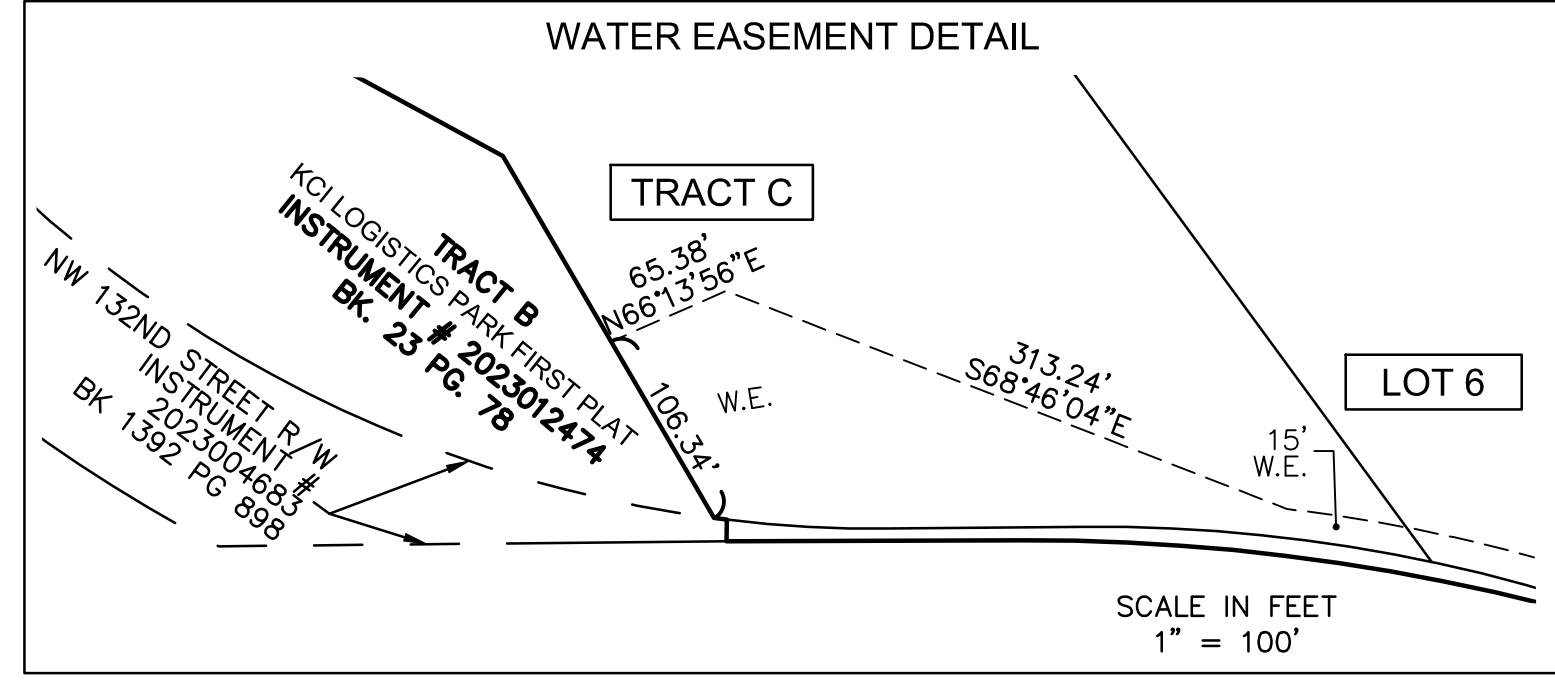
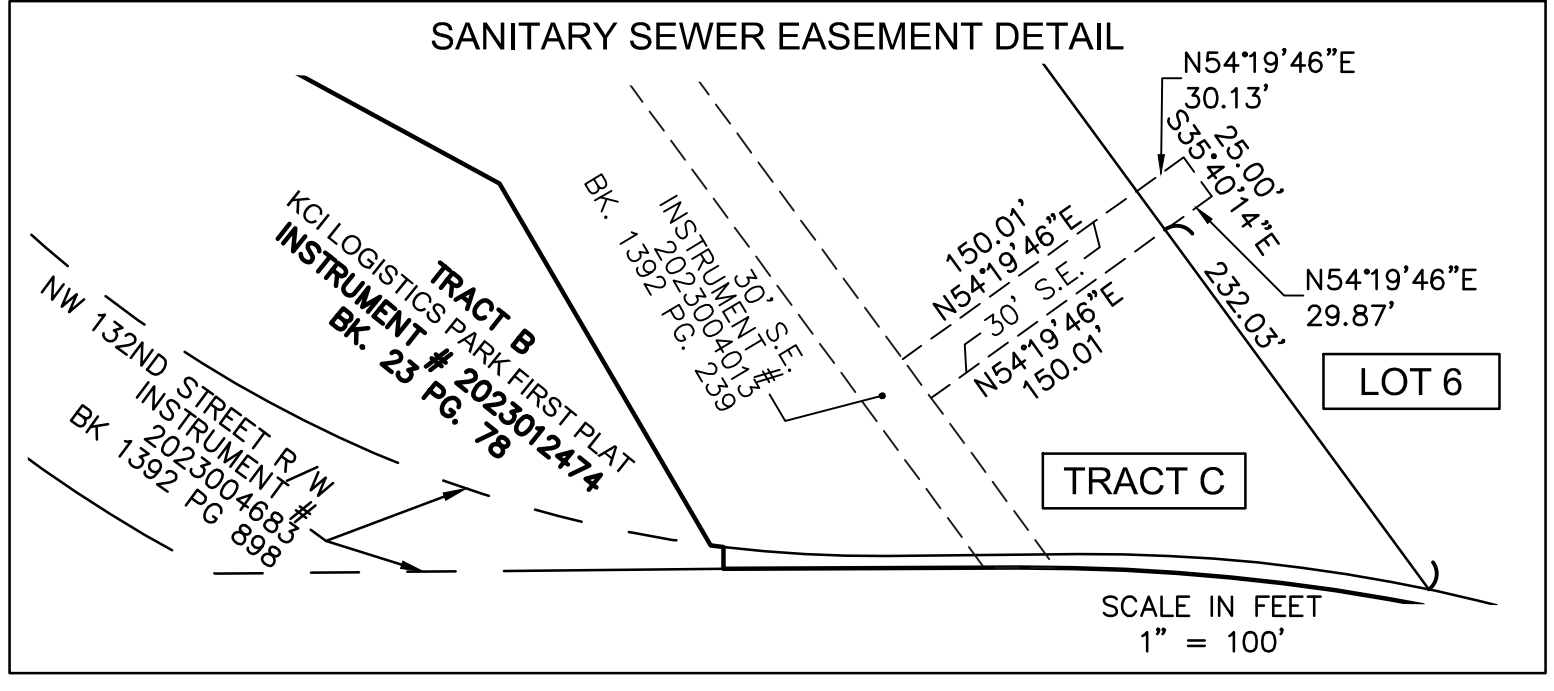
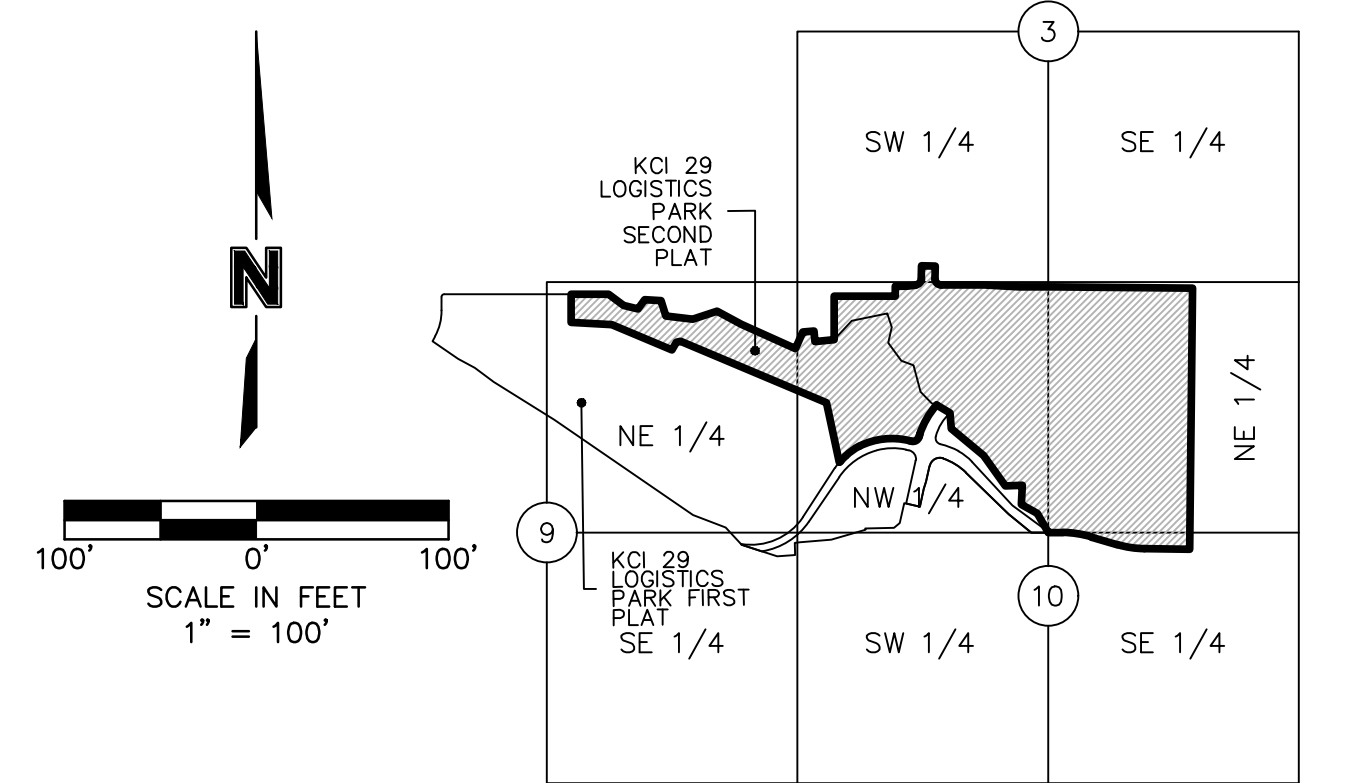

SURVEYORS NOTES:

- PROPERTY INFORMATION REFERENCING THIS SURVEY WAS TAKEN FROM THE COMMITMENT FOR TITLE INSURANCE REPORT, ISSUED BY CHICAGO TITLE INSURANCE COMPANY, COMMITMENT NO. KCC240449, WITH A COMMITMENT DATE OF MARCH 22, 2024 AT 8:00 A.M.
- BEARINGS USED HEREON ARE BASED ON THE MISSOURI STATE PLANE COORDINATE SYSTEM, NAD 1983, WEST ZONE USING MISSOURI DEPARTMENT OF NATURAL RESOURCES MONUMENT "PL-12" WITH A GRID FACTOR OF 0.9999034. ALL COORDINATES SHOWN ARE IN METERS.
- THE TERM "PER PLAT" IS IN REFERENCE TO KCI LOGISTICS PARK FIRST PLAT, RECORDED DECEMBER 20, 2023 AS INSTRUMENT NUMBER 2023012474 IN BOOK 23 AT PAGE 78 IN PLATTE COUNTY, MISSOURI.
- NO BUILDINGS WITHIN 20' R/W, 10' OF REAR AND SIDE LINES OF LOT 3 AND TRACT A, KCI 29 LOGISTICS PARK FIRST PLAT PER ARTICLE V MINIMUM BUILDING AND SETBACK LINES, MAXIMUM HEIGHT DECLARATIONS SECTION 5.01 PER COVENANTS, CONDITIONS & RESTRICTIONS AFFECTING PROPERTY WITHIN KCI 29 LOGISTICS PARK DOCUMENT RECORDED DECEMBER 20, 2023 AS INSTRUMENT # 2023012477 IN BOOK 1400 AT PAGE 632.

| BOUNDARY LINE TABLE | | |
|---------------------|-------------|----------|
| BOUNDARY LINE ID | BEARING | DISTANCE |
| 3 | N30°15'58"W | 218.16' |
| 60 | S89°46'03"W | 153.89' |
| 61 | N00°28'01"E | 11.33' |

| BOUNDARY CURVE TABLE | | | | |
|----------------------|-------------------------|---------|-----------|--------|
| BOUNDARY CURVE ID | INITIAL TANGENT BEARING | RADIUS | DELTA | LENGTH |
| 2 | N83°09'47"W | 660.00' | 00°34'42" | 6.66' |

| LEGEND | |
|-----------------------|-------------------------------|
| SURVEY MARKERS | |
| ○ FND | FOUND MONUMENT |
| ⊕ SCR | SECTION CORNER |
| ● SET | SET MONUMENT |
| □ ROW | RIGHT OF WAY MARKER |
| BOUNDARIES | |
| --- | SECTION LINE |
| GENERAL | |
| ITB | INITIAL TANGENT BEARING |
| R | RADIUS |
| L | ARC LENGTH |
| D | CENTRAL ANGLE / DELTA |
| C/L | CENTRAL ANGLE |
| EASEMENTS | |
| S.B.E. | STREAM BUFFER EASEMENT |
| S.E. | SANITARY SEWER EASEMENT |
| U.E. | UTILITY EASEMENT |
| D.E. | STORM DRAINAGE EASEMENT |
| W.E. | WATER EASEMENT |
| T.C.D.S.E. | TEMPORARY CUL-DE-SAC EASEMENT |

THIS PLAT AND SURVEY OF KCI 29 LOGISTICS PARK SECOND PLAT WERE EXECUTED BY OLSSON, 1301 BURLINGTON STREET #100, NORTH KANSAS CITY, MISSOURI 64116.

I HEREBY CERTIFY: THAT THE PLAT OF KCI 29 LOGISTICS PARK SECOND PLAT SUBDIVISION IS BASED ON AN ACTUAL SURVEY MADE BY ME OR UNDER MY DIRECT SUPERVISION AND THAT SAID SURVEY MEETS OR EXCEEDS THE CURRENT MISSOURI STANDARDS FOR PROPERTY BOUNDARY SURVEYS AS ESTABLISHED BY THE MISSOURI BOARD FOR ARCHITECTS, PROFESSIONAL ENGINEERS, PROFESSIONAL SURVEYORS AND LANDSCAPE ARCHITECTS AND THE MISSOURI DEPARTMENT OF AGRICULTURE. I FURTHER CERTIFY THAT I HAVE COMPLIED WITH ALL STATUTES, ORDINANCES, AND REGULATIONS GOVERNING THE PRACTICE OF SURVEYING AND PLATTING OF SUBDIVISIONS TO THE BEST OF MY PROFESSIONAL KNOWLEDGE AND BELIEF.

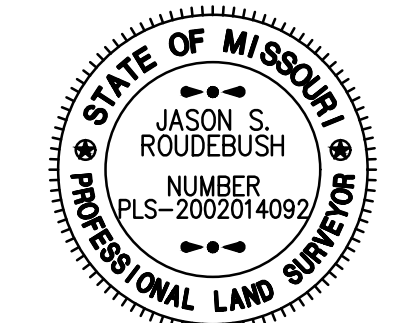

OLSSON, MO CLS 366
 Jason Roudebush, MO PLS 2002014092
 APRIL 30, 2024
 JROUDEBUSH@OLSSON.COM

| DATE OF SURVEY | |
|----------------|---|
| 03-10-2024 | To HMW for Review |
| 03-11-2024 | - 1st Submittal |
| 03-18-2024 | - Title Report Request |
| 04-03-2024 | - To HMW for Review |
| 04-05-2024 | - 2nd Submittal |
| 04-29-2024 | - Revised Plat Boundary to HMW for Review |
| 04-30-2024 | - 3rd Submittal |

drawn by: NRW
 surveyed by: AH-NZ-RN-TG
 checked by: JRM
 approved by: JRM
 project no.: B21-06168
 file name: V_PPLAT_B2106168.DWG

olsson

Olsson - Land Surveying - MO 366, KS 114, MO Certificate of Authority-001592
 1301 Burlington Street TEL 816.361.1177
 North Kansas City, MO 64116 FAX 816.361.1888
www.olsson.com

DWG: F:\2021\06001-06500\021-06168-B\40-Design\Survey\SRVY\Sheets\Plat\V_PPLAT_B2106168.dwg
 DATE: Apr 30, 2024 6:58pm
 USER: nwilloughby