



CITY PLAN COMMISSION STAFF REPORT

City of Kansas City, Missouri
City Planning & Development Department
www.kcmo.gov/cpc

January 23, 2024

Project Name
Staley Shire

Docket #1

Request

CD-CPC-2023-00181 – Development plan

Applicant

Rachelle Biondo
Rouse Frets White Goss Gentile Rhodes
4510 Belleview, Kansas City, MO 64111

Owner

Miles Properties LLC
11201 NE Reinking Rd
Kansas City, MO 64156

Location 11201 NE Reinking Rd.
Area About 24.5 acres
Zoning R-7.5
Council District 1st
County Clay
School District North Kansas City

Surrounding Land Uses

North: Single-family residences zoned R-7, Meadows of Auburndale.

South: Single-family residences on large tracts zoned R-7.

East: Single-family residences zoned R-7, Meadows of Auburndale.

West: Vacant undeveloped agricultural land, zoned R-80.

Major Street Plan

Northeast Reinking Road is not identified on the City's Major Street Plan at this location.

Land Use Plan

The Shoal Creek Valley Area Plan recommends residential low density land use. The request does conform to this recommendation.

APPROVAL PROCESS



PROJECT TIMELINE

The application for the subject request was filed on 12/12/2023. Scheduling deviations from 2024 Cycle 2.1 have occurred to expedite this request as no outside review is warranted.

NEIGHBORHOOD AND CIVIC ORGANIZATIONS NOTIFIED

There are no registered neighborhood or homes associations tied to the subject site.

REQUIRED PUBLIC ENGAGEMENT

Public engagement as required by 88-505-12 does apply to this request. Applicant hosted a meeting on January 9, 2024. A summary of the meeting has not been provided. Public engagement notice attached (#2).

EXISTING CONDITIONS

The subject property is located on the east side of NE Reinking Road in between NE 113th Terrace to the north and NE 108th Street to the south. The site is surrounded by single-family residences within Meadows of Auburndale subdivision to the north and east and Providence Pointe subdivision to the southeast. To the south of the site is single-family residences on large lots zoned R-80. To the west of the site is NE Reinking Road, beyond which is currently undeveloped and owned by North Kansas City School District. The subject site has a single-family house approved with the subdivision to retain this house. The site is generally flat with two detention ponds located to the northwest and southeast corner.

SUMMARY OF REQUEST + KEY POINTS

The applicant is seeking approval to amend the current approved development plan/ preliminary plat in District R-7.5 for the purpose of deleting said plan, on about 25 acres.

CONTROLLING + RELATED CASES

CD-CPC-2021-00066 – Ordinance No. 210567 passed on July 21, 2021, approved a development plan, which also acts as a preliminary plat to create 37 single-family residential lots and 8 tracks on about 24.5 acres.

PROFESSIONAL STAFF RECOMMENDATION

Docket #1 Approval without condition.

PROJECT LOCATION

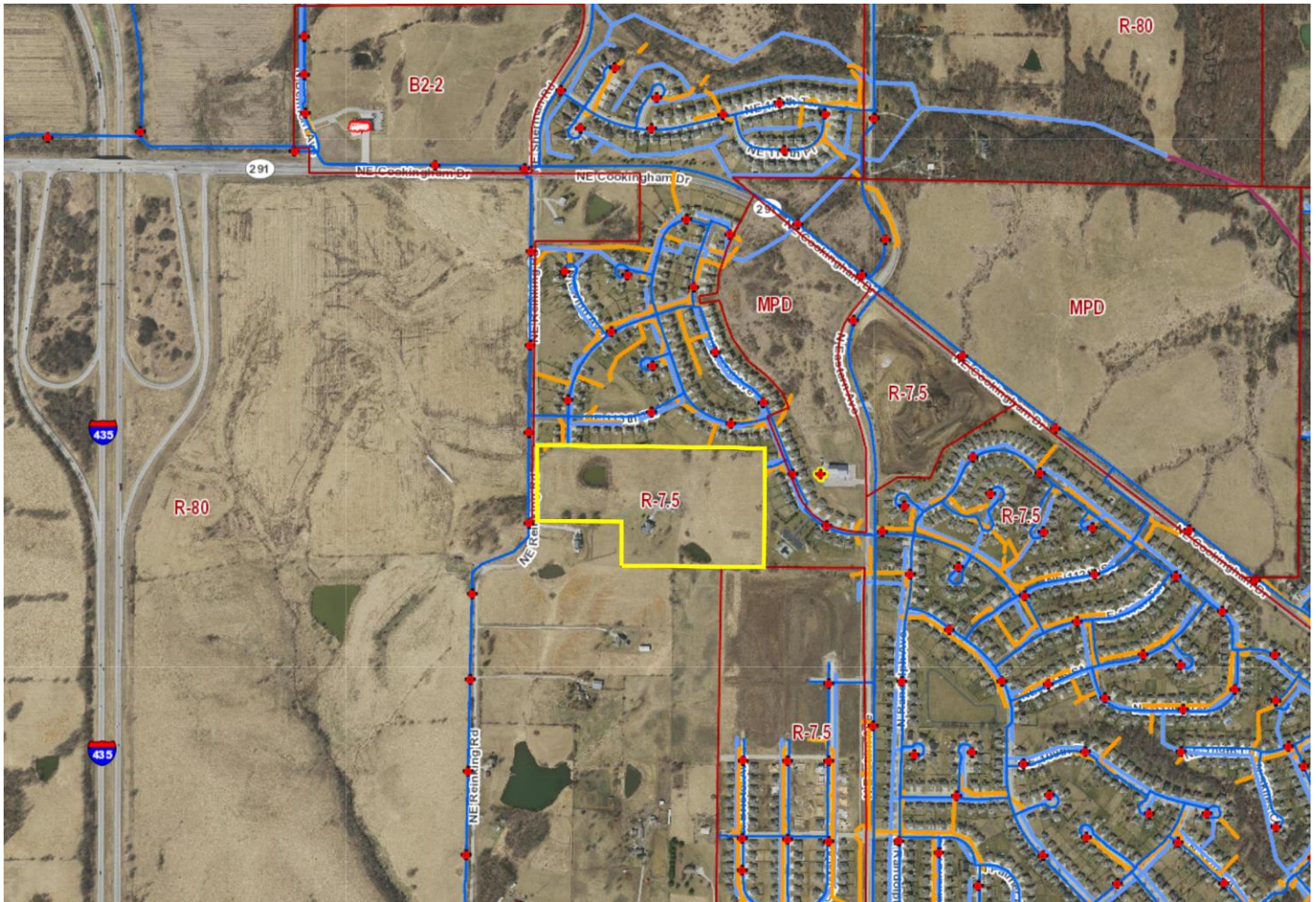

PLAN REVIEW

The applicant is seeking approval of an amendment to the current approved development plan/ preliminary plat in District R-7.5 (Residential) for the purpose of deleting the plan, generally located on the east side of NE Reinking Road, approximately ½ a mile south of NE Cookingham Drive. The plan approved by Ordinance No. 210567 passed by City Council on July 21, 2021, approved a development plan, which also served as a preliminary plat to create 37 single-family residential lots and 8 tracks on about 24.5 acres. The applicant would like to retain the existing house and further subdivide the parcel into large tract of land similar to surrounding parcels to the south and west.

PLAN ANALYSIS

There are six applications associated with this parcel as part of the original development plan approval. Staff recommends that five of the six the accompanying plan/ permits be deleted accordingly to ensure they are not enforceable moving forward. The plans to be deleted along with the development plan include:

1. Case No. CD-CPC-2021-00066 – Development plan/ preliminary plat.
2. Case No. CLD-FnPlat-2021-0047 – Final Plat.
3. Case No. CD-CPC-2021-00179 – Project Plan for POS.
4. Case No. CD-ROW-2021-00035 – Street Naming Plan for Staley Shire.
5. Case No. CLDPIR-2021-00109 - CPLD - Public Infrastructure Review

SPECIFIC REVIEW CRITERIA**Development Plans, Project Plan, or Site Plan (88-516-05)**

In order to be approved, a development plan, project plan, or site plan must comply with all of the following criteria:

- A. The plan must comply with all standards of the Zoning and Development Code and all other applicable city ordinances and policies;**
The development plan complies with the applicable sections of the Zoning and Development Code and the recommended land use of the Shoal Creek Plan. OA
- B. The proposed use must be allowed in the district in which it is located;**
Detached houses are permitted in the current R-7.5 zoning district. OA
- C. Vehicular ingress and egress to and from the site, and circulation within the site must provide for safe, efficient, and convenient movement of traffic not only within the site but on adjacent roadways;**
The proposed plan meets the requirements for vehicular access and circulation. OA
- D. The plan must provide for safe, efficient, and convenient non-motorized travel opportunities, being pedestrian and bicycle movement, on the subject site;**
The proposed development plan is compliant. OA
- E. The plan must provide for adequate utilities based on City standards for the particular development proposed.**
There are adequate utilities proposed for the site. Existing sewer and water main connections are available. OA
- F. The location, orientation, and architectural features, including design and material, of buildings and other structures on the site must be designed to be compatible with adjacent properties.**
The Development Plan is proposing single family homes adjacent to existing home which is compatible with the surrounding land uses. OA
- G. Landscaping, berms, fences, and/or walls must be provided to buffer the site from undesirable views, noises, lighting, or other off-site negative influences and to buffer adjacent properties from negative influences that may be created by the plan.**
The proposed deletion of the development plan does not trigger this requirement. OA
- H. The design of streets, drives, and parking areas within the project should result in a minimum of area devoted to asphalt or other impervious surfaces consistent with the needs of the project and city code requirements.**
The proposed deletion of the development plan does not trigger this requirement. OA
- I. The plan must identify trees to be removed and trees to be preserved during the development of the subject property with the goal of saving trees that are not required to be removed for the development of the property.**
The proposed deletion of the development plan does not trigger this requirement. OA

ATTACHMENTS

1. Applicants Submittal
2. Public Engagement Materials

PROFESSIONAL STAFF RECOMMENDATION

Docket #1 - Approval without condition.

Respectfully Submitted,

A handwritten signature in black ink, appearing to read 'Olofu O. Agbaji'. The signature is fluid and cursive, with the first name 'Olofu' being the most prominent part.

Olofu O. Agbaji
Planner

PLAN TO BE DELETED



Know what's below. Call before you dig.

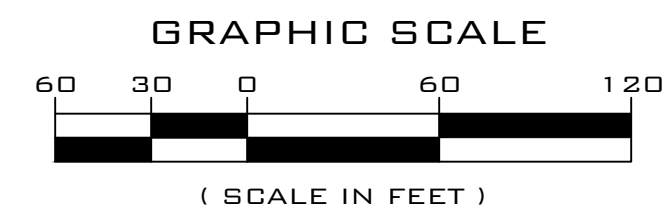
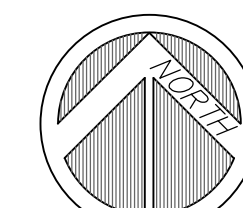

OWNER/APPLICANT

MILES PROPERTIES LLC
11201 NE REINKING RD
KANSAS CITY, MO 64156

GENERAL NOTES - RESIDENTIAL

- A. TOTAL LAND AREA: 24.50 ACRES
- B. RESIDENTIAL NET LAND AREA: 16.95 ACRES
- C. TOTAL NUMBER OF DWELLING UNITS: 47
- D. GROSS DENSITY: 1.92 UNITS/ACRE
- E. NET DENSITY: 2.77 UNITS/ACRE

ZONING NOTES

- A. EXISTING ZONING IS R-80
- B. PROPOSED ZONING FOR RESIDENTIAL IS R-7.5
- C. CONSTRUCTION IS TO COMMENCE SUMMER 2021 AND COMPLETE WINTER 2021.

LAND USE TABLE

LOT/TRACT	LAND USE	AREA (ACRES)
1 to 47	SINGLE FAMILY LOTS	16.95
R/W	PUBLIC RIGHT OF WAY	4.45
TRACT A	DETENTION	0.47
TRACT B	DETENTION	0.66
TRACT C	DETENTION	0.37
TRACT D	DETENTION	0.33
TRACT E	PRIVATE OPEN SPACE	0.53
TRACT F	PRIVATE OPEN SPACE	0.55
TRACT G	PRIVATE OPEN SPACE	0.19
TOTAL		24.50

LEGAL DESCRIPTION

All that part of the Southeast Quarter of Section 21, Township 52 North, Range 32 West, in Kansas City, Clay County, Missouri, described as follows: Commencing at the Southeast corner of said Southeast Quarter; thence N89°18'52"W along the South line of said Southeast Quarter, a distance of 1647.99 feet to the point of beginning of the tract of land to be herein described; thence N00°21'57"E, along a line parallel to the East right of way line of NE. Reinking Road, a distance of 300 feet; thence N89°18'52"W, along a line parallel with the South line of said Southeast Quarter, a distance of 575.00 feet to a point on the East right of way line of said NE. Reinking Road; thence N00°21'57"E along said line, a distance of 506.00 feet; thence S89°18'52"E, along a line parallel with the South line of said Southeast Quarter, a distance of 1537.99 feet; thence S00°21'57"W, along a line parallel with the East right of way line of said NE. Reinking Road, a distance of 806.00 feet to a point on the South line of said Southeast Quarter; thence N89°18'52"W, along said line, a distance of 962.99 feet to the point of beginning.

Also known as Lot 2 as shown on the certificate of survey filed 8/13/2020 as document No. 2020028552 in Book 1 at Page 110.1.

GRADING, UTILITIES, AND MISC. NOTES

- 1 - PROPOSED WATERLINE
- 2 - PROPOSED SANITARY SEWER LINE
- 3 - PROPOSED STORM SEWER LINE
- 4 - PROPOSED BMP/DETENTION TREATMENT AREA
- 5 - PROPOSED DOG PARK BENCHES
- 6 - PROPOSED DOG PARK FENCING

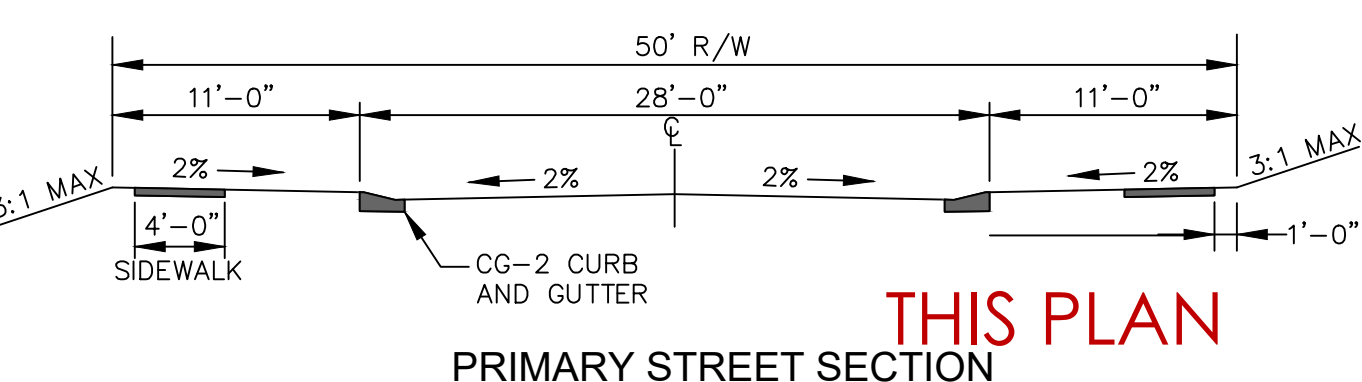

GENERAL NOTES

- A. PROPOSED CONTOURS, BMP'S, GRADES, EASEMENTS, AND UTILITIES ARE INDICATED IN PLAN SET AND ARE SUBJECT TO FINAL ENGINEERING DESIGN AND APPROVED BY DEVELOPMENT SERVICES, PRIVATE UTILITY COMPANIES AND FINAL PLAN APPROVAL. SEE GRADING AND UTILITY PLAN, AND OR STORM WATER MANAGEMENT PLAN.
- B. FINAL BUILDING PLAN WILL INCLUDE FINAL DETAILS ON BUILDING MATERIALS, BUILDING ELEVATIONS, SITE LIGHTING, AND LANDSCAPING.
- C. LOTS OR TRACTS ESTABLISHED BY THIS PLAT MAY BE FURTHER SUBDIVIDED BY APPLICATION FOR LOT SPLIT OR MINOR SUBDIVISION, PROVIDED BUILDING WALLS AND OPENINGS ON OR ADJACENT TO PROPERTY LINES SHALL BE CONSTRUCTED WITH APPROPRIATE FIRE-RESISTIVE RATINGS AS REQUIRED BY CHAPTER 18, KANSAS CITY BUILDING AND REHABILITATION CODE, CODE OF ORDINANCES.
- D. SIGNAGE: ALLOWED PER KANSAS CITY, MO ZONING AND DEVELOPMENT CODE SECTION 88-445 OR AS MAY BE APPROVED BY THE BOARD OF ZONING ADJUSTMENT THROUGH VARIANCES GRANTED BY THE BOARD.
- E. PRELIMINARY DEVELOPMENT PLAN SET SERVES AS THE PRELIMINARY PLAT.
- F. BUILDING SETBACKS ARE INDICATED IN PLAN SET.
- G. MAXIMUM OVERSIGHT RIGHT:
 - FRONT: MIN. 25% LOT DEPTH, 30' MAX
 - REAR: MIN. 25% LOT DEPTH, 30' MAX
 - SIDE: MIN. 10% LOT WIDTH, 8' MAX; IF ABUTTING STREET 15' MIN
- H. MAXIMUM ACCESS TO EACH LOT WILL BE FROM A DEDICATED PUBLIC STREET AND/OR ACCESS EASEMENT.
- J. TYPICAL ROAD SECTION WILL BE PER KANSAS CITY, MISSOURI STANDARDS
- K. PARKING WILL BE PROVIDED AS REQUIRED IN SECTION 88-420 OF THE KANSAS CITY ZONING AND DEVELOPMENT CODE.
- L. STORM WATER DETENTION AND BMP'S SHALL BE PER APPROVED STORM DRAINAGE STUDY OR PER DEPARTMENT OF PUBLIC WORKS. STORM WATER STUDY WILL IDENTIFY DETENTION, VOLUME CONTROL, AND TREATMENT AREAS. PROPOSED STORM WATER SYSTEM AND STORMWATER BMP'S ARE INDICATED ON STORMWATER, GRADING AND UTILITY PLAN.
- M. PROPOSED CONTOURS, GRADES, EASEMENTS, BMP'S, AND UTILITIES ARE INDICATED ON PLAN AND ARE SUBJECT TO FINAL ENGINEERING, AND APPROVED BY KCMO. PRIVATE UTILITIES AND EASEMENTS ARE SUBJECT TO DESIGN BY INDIVIDUAL COMPANIES.
- N. PARKLAND DEDICATION FEES SHALL FOLLOW KCMO ORDINANCE 88-408. REFER TO PARKLAND DEDICATION AND FEE CALCULATION TABLES BELOW. THE TABLES SHOW THE PARKLAND DEDICATION REQUIRED, PARKLAND DEDICATION PROVIDED, REQUIRED IN LIEU OF PARKLAND DEDICATION FEES REQUIRED AND PHASED DEVELOPMENT PARKLAND DEDICATION.

PLAN TO BE DELETED

THIS PLAN APPROVED BY ORDINANCE No. 210567 July 1, 2021

LEGEND

- 980 - EXISTING CONTOUR
- 980 - PROPOSED CONTOUR
- SS - PROPOSED SANITARY SEWER
- SS - EXISTING SANITARY SEWER
- W - PROPOSED WATER
- W - EXISTING WATER
- STM - PROPOSED STORM SEWER
- B-t - BUILDING FOOTPRINT
- R/W - PROPOSED R/W
- R/W - EXISTING R/W
- Pt - PROPERTY LINE

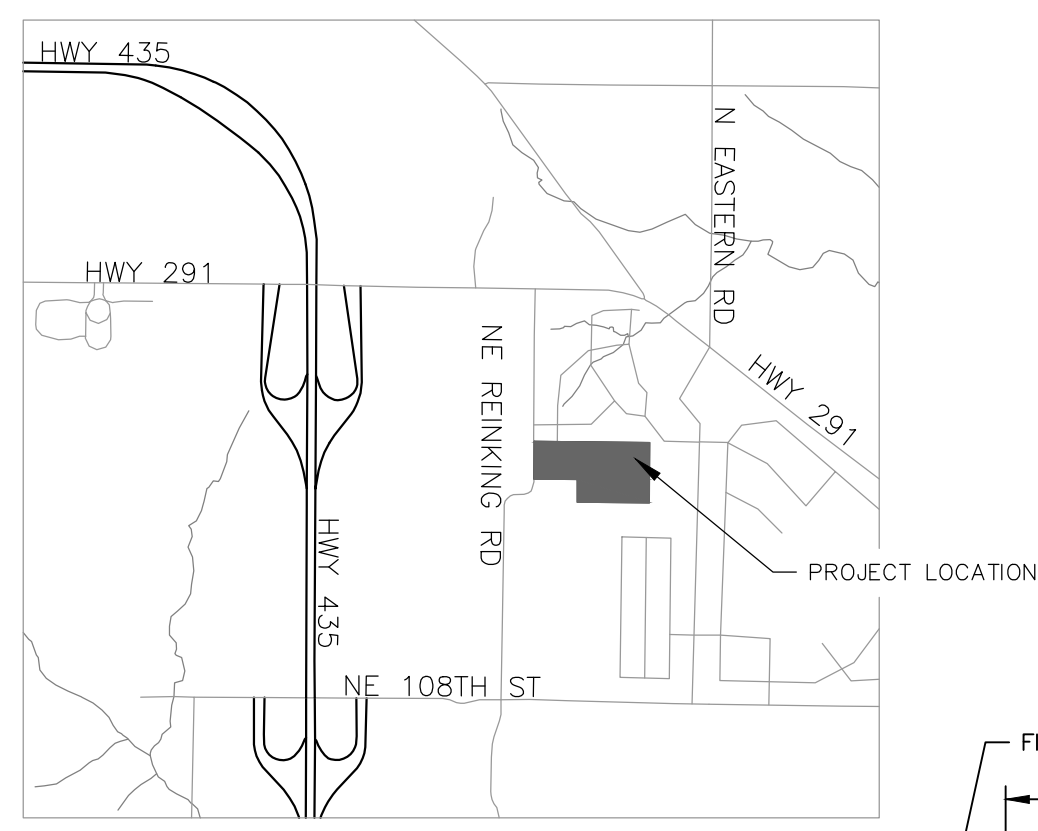

LOTS	EXISTING ZONING	PROPOSED ZONING	GROSS AREA (AC.)	PROPOSED STREET R/W (AC.)	PRIVATE OPEN SPACE (AC.)	STORM DETENTION (AC.)	NET AREA (AC.)	LAND USE
1-47	R-80	R-7.5	24.50	4.45	1.27	1.83	16.95	SINGLE FAMILY RESIDENTIAL

LOT	BUILDING USE	BUILDING FLOOR AREA (SF)	NUMBER OF BUILDINGS	TOTAL SQ FT	NUMBER OF FLOORS	MAX FLOOR AREA RATIO	FLOOR AREA RATIO
1-47	SINGLE FAMILY RESIDENTIAL		47				

Land Use Type	Number of Dwellings	People Per Dwelling	Acre Required Per Person	Required Dedication (acres)	Cost Per Acre	Required Fees
Single Family	47	3.7	0.006	1.04	\$48,801.37	\$50,753.42

Type of Parkland Dedication	Length of Trail (ft)	Dedicated Trail Section Width (ft)	Area of Parkland Dedication (sqft)	Area of Parkland Dedication (acres)
8' Trail	810	30.00	24300	0.60
Dog Park				0.53
Total Provided Parkland Dedication				1.13

Required for Dedication (Acres)	Total Provided Area (Acres)
1.04	1.13
Acres Owed After Parklands Dedication	0.00
Amount Owed After Parklands Dedication	0.00

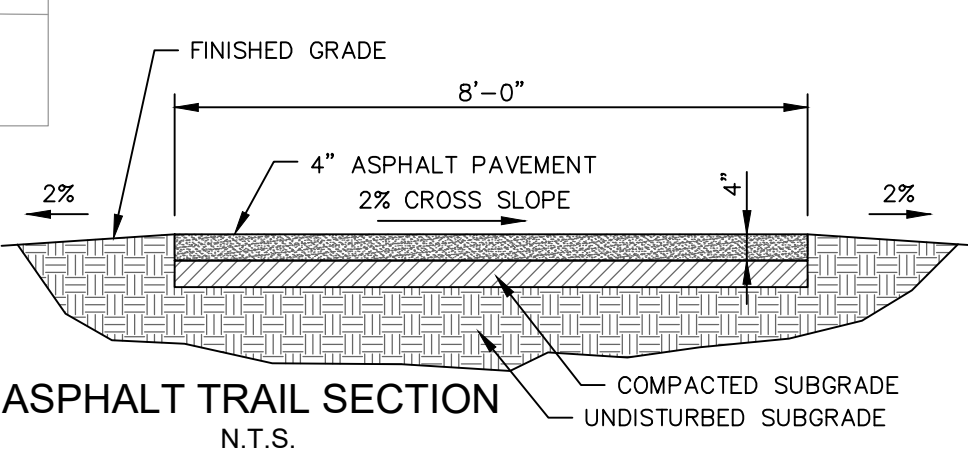

MILBURN CIVIL ENGINEERING, LLC
33135 W 83RD ST
DE S070, KS 66018
913-583-0367

STALEY SHIRE
DEVELOPMENT PLAN / PRELIMINARY PLAT
11201 NE REINKING ROAD
KANSAS CITY, MISSOURI

DATE DESIGNED BY: 6/21/2021 KFC
CHECKED BY: JPM

REVISIONS

NO.	DESCRIPTION	DATE

PRELIMINARY-NOT FOR CONSTRUCTION

C100

December 18, 2023

VIA U.S. MAIL

To Adjacent Neighbors

Re: Deletion of Development Plan; Neighborhood Meeting

Dear Property Owner:

We represent Miles Properties LLC concerning property located at 11201 NE Reinking Road. We submitted an application to the City Plan Commission for approval of deletion of the current approved Development Plan (Case Number CD-CPC-2023-00181).

Approval of our application will allow the currently approved Development Plan be abandoned to allow for replatting of the property into three (3) lots. A copy of the approved Development Plan is enclosed.

You are receiving this notice in accordance with city code that requires a public meeting with neighborhoods for certain types of development projects and that all property owners within 300 feet are invited. This public meeting is an opportunity for you to come learn more about the Development Plan and discuss these plans with the developer's representatives. You can read more about the process requirements at kcmo.gov/publicengagement. If you would like further information on this proposed project, please visit Kansas City's planning and permitting system, Compass KC, at Compasskc.kcmo.org. You may search by project type and address/case number to find project details.

This public meeting will be held by Zoom conference call Tuesday, January 9, 2024 at 6:00 p.m.

Join the Zoom Meeting at <https://zoom.us/join>. Call-in instructions are as follows:

Meeting ID: 860 7696 8020
Passcode: 595045
Or dial: 312 626 6799

Any questions or concerns can be addressed to:

Name: Patricia R. Jensen
Email: pjensen@rousepc.com
Phone: 816-502-4723
Title/Role: Attorney
Company: Rouse Frets White Goss Gentile Rhodes, P.C.
Representing: Miles Properties LLC

{33913 / 70728; 1008746. }

December 18, 2023

Page 2

If you are unable to participate in the Zoom conference call on January 9, 2024 and you have questions or comments, please either call me or e-mail me at the above phone number/e-mail address.

The Applications will be heard by the City Plan Commission on Tuesday, January 16, 2024.

Sincerely,

A handwritten signature in cursive script, appearing to read "Patricia R. Jensen".

Patricia R. Jensen

PRJ:jjw

Enclosure

cc: City Planning and Development, publicengagement@kcmo.org
Mr. Darin Miles
Mr. Justin Milburn