



**City of Kansas City, Missouri  
Water Services Department  
Kenneth C. Morgan P.E, Director**

# **Project Manual**

**PROJECT/CONTRACT NOS. 80002486/9829-1**

**EMERGENCY WATER DISTRIBUTION  
SYSTEM REPAIRS RENEWAL NO. 1**

## **BIDDER/ADDRESS**

<b>Company</b>	<b>Infrastructure Solutions, LLC.</b>
<b>Contact</b>	<b>Jason Conklin</b>
<b>Address</b>	<b>9801 Renner Boulevard Lenexa, Kansas 66219</b>
<b>Phone</b>	<b>913-492-0400</b>
<b>Email</b>	<b><a href="mailto:jconklin@isolutionsllc.com">jconklin@isolutionsllc.com</a></b>

Project Manager: Jason Wright  
Telephone: 816-513-4772  
Email: [Jason.wright@kcmo.org](mailto:Jason.wright@kcmo.org)



File #: 230959

ORDINANCE NO. 230959

Authorizing a \$2,400,000.00 construction contract with Infrastructure Solutions, LLC, for the Emergency Water Distribution Repairs project; and authorizing two successive renewal options with further City Council approval.

BE IT ORDAINED BY THE COUNCIL OF KANSAS CITY:

Section 1. That the Director of the Water Services Department is authorized to execute Contract No. 9829 in the amount of \$2,400,000.00 with Infrastructure Solutions, LLC, for the Emergency Water Distribution Repairs project, Project No. 80002486. A copy of the contract is on file in the office of Water Services.

Section 2. That the Director of Water Services is authorized to expend the following amounts from the listed accounts for previously appropriated dollars to satisfy the contract:

24-8010-807705-B-80002486	Water Main Replacement Program	\$2,000,000.00
24-8010-802010-B	Distribution - Pipeline	<u>400,000.00</u>
	TOTAL	\$2,400,000.00

Section 3. That the Director of Water Services is hereby authorized to execute two successive one-year renewal options for this contract with additional Council approval with such funds as appropriated by the Council in future annual budgets.

I hereby certify that there is a balance, otherwise unencumbered, to the credit of the appropriation to which the foregoing expenditure is to be charged, and a cash balance, otherwise

unencumbered, in the treasury, to the credit of the fund from which payment is to be made, each sufficient to meet the obligation hereby incurred.



Tammy L. Queen  
Director of Finance

Approved as to form:



Mark P. Jones  
Senior Associate City Attorney



Authenticated as Passed



Quinton Lucas, Mayor

  
Marilyn Sanders, City Clerk

NOV 30 2023

Date Passed



## CERTIFICATION PAGE

Project/Contract Numbers 80002486/9829-1

Project Title: Emergency Water Distribution System Repairs

---

I am responsible for the following specifications and drawings:

Specifications:

**DIVISION 2-** 2200, 2250, 2618,2641,2645,2669.

**DIVISION 3-** 3000

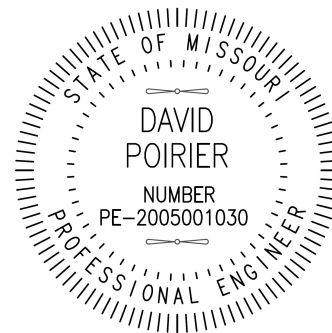

\_\_\_\_\_  
(SEAL)

---

I am responsible for the following specifications and drawings:

Drawings:

Specifications:

\_\_\_\_\_  
(SEAL)

---

I am responsible for the following specifications and drawings:

Drawings:

Specifications:

\_\_\_\_\_  
(SEAL)

---

I certify under penalty of law that the document and all attachments were prepared under my direction or supervision in accordance with a system designed to assure that qualified personnel properly gathered and evaluated the information submitted, and that the information submitted is, to the best of my knowledge and belief, true, accurate, and complete. I am aware that there are significant penalties for submitting false information, including the possibility of fine and imprisonment for knowing violations.



## TABLE OF CONTENTS

Project/Contract Numbers: 80002486/9829-1

Project Title: Emergency Water Distribution System Repairs  
Renewal No. 1

### **INTRODUCTORY INFORMATION**

00005	Certification Page
00010	Table of Contents

### **BIDDING REQUIREMENTS**

00410	Bid Form
00410.03	List of Equipment and Staffing
00412	Unit Prices
00440	CREO KC 5 Construction Contract Instructions
00450	CREO KC 08 Contractor Utilization Plan/Request for Waiver
00450.01	CREO KC Letter of Intent to Subcontract
00460	CREO KC 10 Timetable for MBE/WBE Utilization
00470	CREO KC 11 Request for Modification or Substitution
00485	CREO KC Monthly Reporting Instructions
00485.01	MWBE Monthly Utilization Report
00485.01.1	MWBE Monthly Utilization Report Instructions
00485.02	Project Specific Workforce Monthly Report
00485.02.1	Workforce Monthly Report Instructions
00485.03	Company-Wide Workforce Monthly Report CREO Close Out Form

### **CONTRACTING REQUIREMENTS**

00515	Construction Contract Required Submissions
00515.01	Employee Eligibility Verification Affidavit
00560	Missouri Project Exemption Certificate
00560.01	Kansas City Missouri Tax Exempt Certificate
00610	Performance and Maintenance Bond Form
00615	Payment Bond Form
00620	Insurance Certificate Forms
00630	Revenue Clearance Release Authorization
00700	General Conditions
00800	Supplementary Conditions
00830	Wage Rate Requirements – Cass, Clay, Jackson, Platte & Ray Counties
00930	Request for Interpretation Form
00930.01	Request for Interpretation Form Log
00931	Supplemental Design Instructions
00932	Request for Proposal
00933	Request for Proposal Log
00940	Change Order Form
00945	Work Change Directive

**DIVISION 1 - GENERAL REQUIREMENTS**

01000	General Project Requirements
01270	Measurement and Payment
01290.01	Application for Payment
01290.02	Schedule of Values
01290.09	Subcontractors and Major Material Suppliers List
01290.11	Daily Labor Force Report
01290.12	Certificate of Substantial Completion
01290.13	Punch List
01290.14	Contractor Affidavit for Final Payment
01290.15	Subcontractor Affidavit for Final Payment
01320.01	Daily Field Observation Report
01320.02	Periodic Field Observation Report
01320.03	Working Day Report
01330.01	Letter of Transmittal
01630	Substitution Request
01700	Traffic Control

**DIVISION 2 – SITEWORK**

02200M	Earthwork
02250	Trenching, Pipe Embedment and Backfill
02618	Ductile Iron Pipe Water Main
02641	Valves
02645M	Hydrants and Flushing Assemblies
02669M	Thrust Restraints

**DIVISION 3 – CONCRETE**

03000	Miscellaneous Concrete
-------	------------------------

**DIVISION 4-16 NOT USED**

CITY OF FOUNTAINS  
HEART OF THE NATION



KANSAS CITY  
MISSOURI

### BID FORM/CONTRACT

Project/Contract Numbers: 80002486/9829-1

Project Title: Emergency Water Distribution System Repairs Renewal No. 1

1. Bidder, having examined the Bidding Documents, related documents and the Site of the Work, and being familiar with all the conditions affecting the construction of the proposed Work, including Laws and Regulations and the availability of materials and supplies, agrees, if this Bid is selected by CITY, this Bid Form/Contract will become the Contract between Bidder and CITY for Bidder to furnish all labor and materials, equipment and services necessary for the proper completion of the Work in accordance with the Contract Documents, including general construction work at the price(s) stated below, which stated sums include fees and all other charges applicable to materials, appliances, labor and all things subject to and upon which other charges may be levied.
2. Bidder agrees the Contract Documents will comprise the entire agreement between CITY and Bidder. The Contract Documents are identified in the General Conditions and are incorporated into and made part hereof this Bid Form/Contract by reference.
3. Bidder agrees that if this Bid Form/Contract is executed by CITY, Bidder's offer is accepted and this Bid Form/Contract that incorporates all other Contract Documents shall constitute the Contract between the parties. Bidder authorizes the CITY to fill in the Contract Price on this Bid Form/Contract in accordance with Bidder's Bid. Bidder agrees that this Bid Form/Contract may be executed in one or more counterparts, each of which will be deemed an original copy of this Bid Form/Contract and all of which, when taken together, will be deemed to constitute one and the same Bid Form/Contract. This Bid Form/Contract shall be effective upon the execution of counterparts by both parties, notwithstanding that both parties may not sign the same counterpart. The parties' signatures transmitted by facsimile or by other electronic means shall be proof of the execution of this Bid Form/Contract and shall be acceptable in a court of law. A copy of this Bid Form/Contract shall constitute an original and shall be acceptable in a court of law.
4. The maximum obligation of the CITY for the Work is \$2,700,000.00, includes Unit Prices. The sum of the extensions of the Unit Prices for is \$2,210,759.07. The actual number of units worked and paid for under this Contract may be more or less than the estimated Quantity given or may be none.
5. The Bidder agrees to enter into One (1) successive renewals to this Contract if so requested by the CITY. The determination to renew the contract will be at the sole discretion of the CITY where such renewal would be in the best interest of the CITY and subject to the availability and appropriation of funds. An increase in a unit price, if any, will be determined solely by the CITY, and if needed, will not exceed the change in the Consumer Price Index for the period since the Contract was signed.
6. The undersigned Bidder agrees that this Bid shall remain subject to selection by CITY, and may not be withdrawn for ninety (90) days after the day Bids are opened.
7. The undersigned Bidder certifies that this Bid contains no modifications, deviations, riders or qualifications.
8. The undersigned Bidder acknowledges receipt of the following addenda listed by number and date appearing on each addendum:

Addendum Number	Dated	Addendum Number	Dated
(_____)	(_____)	(_____)	(_____)

(_____)	(_____)	(_____)	(_____)
(_____)	(_____)	(_____)	(_____)
(_____)	(_____)	(_____)	(_____)
(_____)	(_____)	(_____)	(_____)
(_____)	(_____)	(_____)	(_____)
(_____)	(_____)	(_____)	(_____)

9. By submitting its bid, Bidder is agreeing to meet or exceed the minimum employment goals of 10% minority and 2% women during the term of its contract with the City, or request a waiver of the goals. If a waiver is requested, Bidder must establish good faith efforts towards meeting the goals as set forth in the CREO KC Instructions for Construction Contracts and the City’s Construction Employment Program Ordinance (commonly known as the “Workforce Ordinance”) (City Code Section 3-515). Within forty-eight (48) hours after bid opening, the construction contractor shall submit **CREO KC Employee Identification Report Form**, which shall include: the name, home address, job title, sex and race/ethnicity of each person the contractor anticipates will be performing construction labor hours creditable towards the minimum workforce goals applicable to the construction contractor individually.
10. Should Bidder fail to meet or exceed the minimum employment goals or otherwise establish that Bidder is entitled to a waiver under circumstances in which Bidder has previously failed to meet or exceed the goals on one or more occasions with the twenty-four month period immediately preceding the completion of the Work under this Bid Form/Contract, Bidder may be suspended from participating, either as a contractor or subcontractor, on any future contract with the City for a period ranging from thirty days to six months as further specified in the Contract Documents. This program is distinguished from the M/WBE Program in that it is not based on company ownership but rather is based on workforce hours instead of a budgetary allocation of work.
11. By submitting its bid, Bidder warrants that if its bid should exceed \$300,000.00 and Bidder employs fifty (50) or more people, Bidder has an affirmative action program in place and will maintain the affirmative action program in place for the duration of its contract with the City. Bidder further warrants that it will comply with the affirmative action requirements contained in the General Conditions as incorporated by reference into this Bid Form/Contract.
12. Section 13 through Section 16 constitutes the Affidavit of Intended Utilization required to be submitted by Bidders.
13. By submitting its bid, Bidder is agreeing to the following: (1) Bidder has made by bid opening a good faith effort to meet the MBE/WBE/DBE goals established for the project; or Bidder will continue to make during the 48 hours after bid opening a good faith effort to meet the MBE/WBE/DBE goals established for the project; and (2) Bidder will timely submit its **00450 CREO KC 08 Contractor Utilization Plan/Request for Waiver** and **00450.01 CREO KC Letter of Intent to Subcontract** for each MBE/WBE listed on the 00450 CREO KC 8 Construction Contractor Utilization Plan/Request for Waiver; and (3) Bidder will submit documentation of its good faith efforts to meet the MBE/WBE/DBE goals when requested by the City. Failure to meet these requirements in good faith will result in Bidder forfeiting its bid bond.

**PROJECT GOALS:**                                11% MBE                                11% WBE                                0% DBE  
**BIDDER PARTICIPATION:**                \_\_\_\_\_ % MBE                                \_\_\_\_\_ % WBE                                \_\_\_\_\_ % DBE



14. To the best of Bidder’s knowledge, the following are names of certified MBEs and/or WBEs with whom Bidder, or Bidder’s subcontractors, presently intend to contract with if awarded the Contract on the above project: **(All firms must currently be certified by Kansas City, Missouri Civil Rights & Equal Opportunity – CREO KC – Department)**

A. Name of M/WBE Firm \_\_\_\_\_  
Address \_\_\_\_\_  
Telephone No. \_\_\_\_\_  
I.R.S. No. \_\_\_\_\_  
Area/Scope of work \_\_\_\_\_  
Subcontract amount \_\_\_\_\_

B. Name of M/WBE Firm \_\_\_\_\_  
Address \_\_\_\_\_  
Telephone No. \_\_\_\_\_  
I.R.S. No. \_\_\_\_\_  
Area/Scope of work \_\_\_\_\_  
Subcontract amount \_\_\_\_\_

C. Name of M/WBE Firm \_\_\_\_\_  
Address \_\_\_\_\_  
Telephone No. \_\_\_\_\_  
I.R.S. No. \_\_\_\_\_  
Area/Scope of work \_\_\_\_\_  
Subcontract amount \_\_\_\_\_

D. Name of M/WBE Firm \_\_\_\_\_  
Address \_\_\_\_\_  
Telephone No. \_\_\_\_\_  
I.R.S. No. \_\_\_\_\_  
Area/Scope of work \_\_\_\_\_  
Subcontract amount \_\_\_\_\_

E. Name of M/WBE Firm \_\_\_\_\_  
Address \_\_\_\_\_  
Telephone No. \_\_\_\_\_  
I.R.S. No. \_\_\_\_\_  
Area/Scope of work \_\_\_\_\_  
Subcontract amount \_\_\_\_\_

F. Name of M/WBE Firm \_\_\_\_\_  
Address \_\_\_\_\_  
Telephone No. \_\_\_\_\_  
I.R.S. No. \_\_\_\_\_  
Area/Scope of work \_\_\_\_\_  
Subcontract amount \_\_\_\_\_

*(List additional MBE/WBEs, if any, on additional pages and attach to this form)*

15. By submitting its bid, Bidder is agreeing it will identify and timely submit within 48 Hours after Bid opening those MBE/WBE subcontractors with dollar amounts and scopes of work, which apply to or exceed the MBE/WBE goals for the Project on the **00450 CREO KC 08 Contractor Utilization Plan/Request for Waiver.**

16. Bidder agrees that failure to meet or exceed the MBE/WBE Goals for the above project will require the Director of the Civil Rights & Equal Opportunity (CREO KC) Department to recommend disapproval of the bid unless the Director of CREO KC finds the Bidder established good faith efforts towards meeting the goals as set forth in the CREO KC Forms and Instructions for Construction Projects and the City's MBE/WBE Ordinance.

Business Entity Type:

- Missouri Corporation
- Foreign Corporation
- Fictitious Name Registration
- Sole Proprietor
- Limited Liability Company
- Partnership
- Joint Venture
- Other: (Specify) \_\_\_\_\_

**BIDDER**

Legal name & address of Bidder, person firm, partnership, corporation, or association submitting Bid:

\_\_\_\_\_  
 Phone No: \_\_\_\_\_  
 Cell No: \_\_\_\_\_  
 Facsimile No: \_\_\_\_\_  
 Bidder's E-Mail: \_\_\_\_\_  
 \_\_\_\_\_  
 Federal ID. No. \_\_\_\_\_

I hereby certify that I have authority to execute this document on behalf of Bidder, person, firm, partnership, corporation or association submitting Bid.

By: \_\_\_\_\_  
(Signature)

\_\_\_\_\_  
(Print Name)

Title: \_\_\_\_\_

Date: \_\_\_\_\_

(Attach corporate seal if applicable)

**NOTARY**

Subscribed and sworn to before me this \_\_\_\_\_ day of \_\_\_\_\_, 20\_\_.

My Commission Expires: \_\_\_\_\_

**ACCEPTANCE OF BID**

CITY, by executing this Bid Form/Contract, hereby accepts Bidder's Bid and this Bid Form/Contract that incorporates all other Contract Documents shall constitute the Contract between the Parties.

CITY shall pay CONTRACTOR for completion of the Work in accordance with the Contract Documents a maximum amount of Two Million Seven Hundred Thousand Dollars and No/100, (\$2,700,000,.00). The Contract Price includes:

00412 Unit Prices, included in the Bid, a copy of which is attached

By executing this Bid Form/Contract, CITY accepts Bidder's offer for the Contract Price stated above and this Bid Form/Contract that incorporates all other Contract Documents shall constitute the Contract between the parties

---

City of Kansas City, Missouri (OWNER or City)

Approved as to form:

---

Assistant City Attorney

I hereby certify that there is a balance, otherwise unencumbered, to the credit of the appropriation to which the foregoing expenditure is to be charged, and a cash balance, otherwise unencumbered, in the treasury, to the credit of the fund from which payment is to be made, each sufficient to meet the obligation hereby incurred.

---

Director of Finance

(Date)



## UNIT PRICES

Project/Contract No.: 80002486/9829-1

Project Title: Emergency Water Distribution System Repairs

**NOTE: IN THE EVENT OF DISCREPANCY, UNIT PRICE SHALL GOVERN.**

Item No.	Unit	Quantity	Item Description:	Unit Price	Extension
1	Hour	600	Two-Person Crew for Related Work w/o Excavation	\$ 157.59	\$ 94,554.00
2	Hour	50	Two-Person Crew for Related Work w/o Excavation - Regular Over-time	\$ 214.24	\$ 10,712.00
3	Hour	20	Two-Person Crew for Related Work w/o Excavation - Double Over-time	\$ 288.40	\$ 5,768.00
4	Hour	70	Two-Person Crew for Repair/Replacements	\$ 298.70	\$ 20,909.00
5	Hour	30	Two-Person Crew for Repair/Replacements - Regular Over-time	\$ 355.35	\$ 10,660.50
6	Hour	10	Two-Person Crew for Repair/Replacements - Double Over-time	\$ 440.74	\$ 4,407.40
7	Hour	3000	Three-Person Crew for Repair/Replacements	\$ 369.77	\$ 1,109,310.00
8	Hour	200	Three-Person Crew for Repair/Replacements - Regular Over-time	\$ 453.20	\$ 90,640.00
9	Hour	30	Three-Person Crew for Repair/Replacements - Double Over-time	\$ 572.68	\$ 17,180.40
10	Ton	1100	Granular Embedment	\$ 32.96	\$ 36,256.00
11	Hour	225	Hauling/Disposal - Single Axle Dump Truck	\$ 211.15	\$ 47,508.75
12	Hour	1250	Hauling/Disposal - Tandem Axle Dump Truck	\$ 221.45	\$ 276,812.50
13	Cu. Yd	950	Concrete	\$ 195.70	\$ 185,915.00
14	Cu. Yd	900	Diggable Flowable Fill	\$ 128.75	\$ 115,875.00
15	Hour	120	Two-Person Crew with Vacuum Excavator for Repairs	\$ 195.70	\$ 23,484.00
16	Each	12	Monthly Project Superintendence	\$ 4,487.71	\$ 53,852.52
17	Each	TBD	Specialized Traffic Control		
18	Per Day	60	Street Plate	\$ 82.40	\$ 4,944.00
19	Each	TBD	Materials Not Available from Owner's Stores		
20	Each	TBD	Other Specialized or Unique Services, Labor, Equipment		
21	Each	30	Weekday On-call per crew (24 hour period)	\$ 463.50	\$ 13,905.00
22	Each	190	Weekend/ Holiday On-call per crew (24 hour period)	\$ 463.50	\$ 88,065.00
			Total Unit Prices: (LAST PAGE ONLY)		TOTAL \$ \$ 2,210,759.07

Note: May be printed, for manual fill-in, or filled in on electronic excel spreadsheet version.

**CREO KC INSTRUCTIONS  
FOR CONSTRUCTION CONTRACTS**

**PART A. ECONOMIC EQUITY & INCLUSION GOALS--MBE/WBE PROGRAM**

**I. City's Economic Equity & Inclusion Goals--MBE/WBE Program.**

- A. The City has adopted an Economic Equity & Inclusion Goals--Minority/Women Business Enterprise ("MBE/WBE") Program (Sections 3-421 through 3-469, Code of Ordinances) (the "Program") to implement the City's policy of supporting the fullest possible participation in City contracts and change orders of firms owned and controlled by minorities and women. Each construction contract may have an MBE and/or WBE goal for participation. An MBE or WBE goal is a numerical objective the City has set for the contract that may be awarded pursuant to these bid specifications. Goals are stated as a percentage of contract dollars. For example, if an MBE goal for a contract is 10% and a Bidder submits a bid of \$100,000, the goal for MBE participation would equal \$10,000. The specific MBE/WBE goals on this contract are set forth elsewhere in the bid specifications.
- B. These Civil Rights & Equal Opportunity Department ("CREO KC") Forms & Instructions are part of the BIDDING DOCUMENTS and CONTRACT DOCUMENTS as defined in the General Conditions. By submitting a Bid, the Bidder agrees, as a material term of the contract, to carry out the City's MBE/WBE Program by making good faith efforts to include certified MBE/WBEs in the contract work to the extent of the goals listed for the contract and to the fullest extent consistent with submitting the lowest and best bid to the City. Bidder agrees that the Program is incorporated into this document and agrees to follow the Program. Although it is not a requirement that a Bidder in fact meet or exceed both the MBE and WBE Goals, it is a requirement for approval of the Bid that a Bidder objectively demonstrate to the City that good faith efforts have been made to meet the Goals. Bidders must attempt to meet both the MBE and WBE goals and request a waiver if either is not met.
- C. The following CREO KC Forms are attached and must be used for MBE/WBE submittals:
1. Contractor Utilization Plan/Request for Waiver (CREO KC Form 8); and
  2. Letter of Intent to Subcontract (CREO KC Form 00450.01); and
  3. Timetable for MBE/WBE Utilization (CREO KC Form 10); and
  4. Request for Modification or Substitution (CREO KC Form 11); and
  5. Contractor Affidavit for Final Payment (Form 01290.14); and
  6. Subcontractor Affidavit for Final Payment (Form 01290.15).

Warning: The City only gives MBE/WBE credit for a Bidder's use of City certified MBE/WBEs. A certified MBE/WBE firm is a firm that has been certified by the City's Civil Rights & Equal Opportunity Department as such. An MBE/WBE firm must be certified before the date on which the contractor utilization plan is due. Certified MBEs and WBEs are listed in the M/W/DBE Kansas City Mo. Online Directory, which is available on the City's website at [www.kcmo.org](http://www.kcmo.org). Before a Bidder submits a bid, Bidder



should contact CREO KC and consult the directory to make sure any firm proposed for use for MBE/WBE participation has been certified.

## **II. Required Submissions Following Bid Opening.**

A. Bidder must submit the following documents within forty-eight (48) hours of bid opening:

1. **Contractor Utilization Plan/Request for Waiver (CREO KC Form 8).** This form states a Bidder's plan to use specific certified MBE/WBEs in the performance of the contract and includes the following:
  - a. The work to be performed by each MBE/WBE and the amounts each is to be paid for the work; and
  - b. The name, address, race or ethnic origin, gender and employer identification number or social security number of each MBE/WBE that will perform the work.
  - c. An automatic request for waiver in the event Bidder has not met or exceeded the MBE and/or WBE goals for the contract but believes that it has made good faith efforts to meet or exceed the goals and desires a waiver of the goals. If a waiver is requested, CREO KC will examine the Bidder's documentation of good faith efforts and make a recommendation to grant or deny the waiver. CREO KC will recommend a waiver be granted only if the Bidder has made good faith efforts to obtain MBE/WBE participation.
2. **Letter(s) of Intent to Subcontract (CREO KC Form 00450.01).** A letter must be provided from each MBE/WBE listed on the Contractor Utilization Plan. These letters verify that the MBE/WBE has agreed to execute a formal agreement for the work and indicate the scope of work to be performed and the price agreed upon for the work.

## **III. Required Submission when Requested by City.**

A. Bidder must submit the following documents when requested by City:

1. **Timetable for MBE/WBE Utilization (CREO KC Form 10).**
2. **Documentation of good faith efforts.**

## **IV. Required Monthly Submissions during term of Contract.**

A. Bidder must submit the following report on a monthly basis if awarded the contract:

1. **M/WBE Monthly Utilization Report.** This report must be submitted to the Director by the 15<sup>th</sup> of each month. Failure to submit timely reports may result in delays in processing of current and future contract approvals and payment applications. The method of submission of this report is through the B2GNow Diversity Management System (B2GNow).

## **V. Required Submittals for Final Contract Payment.**

A. Contractor must submit the following documents with its request for final payment under

the contract:

1. **Contractor Affidavit for Final Payment (Form 01290.14)**
2. **Subcontractor Affidavit(s) for Final Payment (Form 01290.15)**
3. **Final B2GNow Monthly Contract Audit Report with all payment audits confirmed.**

#### **VI. Additional Submittals.**

- A. Contractor may be required to make additional submittals during the term of the Contract, including **Request for Modification or Substitution (CREO KC Form 11)**. Refer to Section IX, Modification of the Contractor Utilization Plan or Substitution of an MBE/WBE, for additional instructions on when this form must be submitted.

#### **VII. MBE/WBE Participation Credit.**

- A. The following shall be credited towards achieving the goals:
  1. The total contract dollar amount that a prime contractor has paid or is obligated to pay to a subcontractor that is a certified MBE or WBE, except as otherwise expressly provided for herein.
  2. The total contract dollar amount that a prime contractor that is a certified MBE or WBE performed itself.
  3. Sixty percent (60%) of the total dollar amount paid or to be paid by a prime contractor to obtain supplies or goods from a supplier who is a certified MBE or WBE.
  4. Ten percent (10%) of the total dollar amount paid or to be paid by a prime contractor to obtain supplies or goods from a supply broker who is a certified MBE or WBE.
  5. One hundred percent (100%) of the total dollar amount paid or to be paid by a prime contractor to a manufacturer of construction supplies who is a certified MBE or WBE.
  6. Subcontractor participation with a lower tier MBE/WBE subcontractor using one of the above methods of participation.
- B. **NO CREDIT**, however, will be given for the following:
  1. Participation in a contract by a MBE or WBE that does not perform a commercially useful function as defined by the Program; and
  2. Any portion of the value of the contract that an MBE or WBE subcontractor subcontracts back to the prime contractor or any other contractor who is not a qualified MBE/WBE; and
  3. Materials and supplies used on the contract unless the MBE/WBE is responsible for negotiating the price, determining quality and quantity, ordering the materials and installing (where applicable) and paying for material itself; and
  4. Work performed by an MBE or WBE in a scope of work other than that in which the MBE or WBE is currently certified.





## **VIII. Methods for Securing Participation of MBE/WBEs and Good Faith Efforts.**

- A. A bidder is required to make good faith efforts to achieve the MBE/WBE goals. Good faith efforts are efforts that, given all relevant circumstances, a Bidder actively and aggressively seeking to meet the goals can reasonably be expected to make. Good faith efforts must be made before the Bidder submits a Contractor Utilization Plan, in other words, within 48 hours of bid opening. However, efforts made to increase participation of MBEs and WBEs following submission of the CUP can be considered as evidence of good faith efforts to meet the goals.
- B. In evaluating good faith efforts, the Director of CREO KC will consider whether the Bidder has performed the following, along with any other relevant factors:
1. Advertised for at least 15 calendar days prior to the bid or proposal due date opportunities to participate in the contract in general circulation media, trade and professional association publications, small and minority business media, and publications of minority and women's business organizations which are included in a list along with their current contact information identified on the directory as the list of publications available to publish such advertisements, which list shall be updated by CREO KC no less than every three (3) month.
  2. Sent written notices at least fifteen (15) calendar days prior to the bid or proposal due date containing the information required in section (9) below, by certified mail, e-mail, or facsimile, to at least 80% of MBEs and WBEs which are included in a list along with their contact information identified on the directory as the list of organizations available to receive such notices, which list shall be updated by CREO KC no less than every three (3) months.
  3. Sent written notices, containing the information required by section (9) below, by certified mail, e-mail or facsimile, to at least 80% of MBEs and WBEs listed on the directory certified in the applicable scopes of work for the particular bid soliciting their participation in the contract at least 15 calendar days prior to the bid or proposal due date.
  4. Attempted to identify portions of the work for qualified MBE and/or WBE participation in order to increase the likelihood of meeting the goals, including breaking down contracts into economically feasible units that take into consideration the capacity of available MBE/WBEs appearing on the CREO KC directory.
  5. At any time prior to submission of the CUP or submittal of a request for modification of a CUP, requested assistance in achieving the goals from the Director and acted on the Director's recommendations.
  6. Conferred with certified MBEs and WBEs which inquired about or responded to the bid solicitation and explained to such MBEs and WBEs the scope and requirements of the work for which their bids or proposals were solicited, and if not all certified MBEs and WBEs in the particular scopes listed on the directory have inquired about or responded to the bid solicitation for each scope of work, then contact by certified mail, e-mail or telephone the greater of ten (10) or 80% of additional certified MBEs and WBEs in the particular scopes of work listed on the directory and offer to confer with such MBEs and WBEs for such particular scope of work and request such MBEs

and WBEs to submit a proposal.

7. Attempted to negotiate in good faith with certified MBEs and WBEs which responded to the bid solicitation or those certified MBEs and WBEs that were conferred with as contemplated in section (6) above, and other qualified MBEs and WBEs, at the option of the bidder, proposer, or contractor, as applicable, to perform specific subcontracts, not rejecting them as unqualified without sound reasons based on a thorough investigation of their capabilities by the bidder, proposer, or contractor; in the event an MBE or WBE is the low bid, but rejected as unqualified, the bidder, proposer, or contractor and the director or board, as applicable, shall provide sound reasons for rejecting such MBE or WBE.
8. Attended pre-bid meeting when such meetings were indicated in the solicitation of bids or otherwise by the bidder, proposer, or contractor, as applicable or by the director provided the director provides written direction to the bidder, proposer, or contractor at the time the goals are recommended.
9. Written notices and advertisements to be provided pursuant to sections (1), (2) and (3) above shall include the following information:
  - a. The bid due date;
  - b. The name of the project;
  - c. The address or general location of the project;
  - d. The location of plans and specifications for viewing;
  - e. Contact information of the prime contractor;
  - f. A general description of the scopes of work that are the subject of the solicitation;
  - g. The goals established for the applicable contract, and if the goals are still subject to board approval, then a statement that the goals as stated are preliminary and are subject to board approval;
  - h. If the project or any portion of the project is subject to prevailing wage then a statement that all or a portion of the project will be subject to prevailing wage, as applicable; and if only a portion of the scopes are subject to prevailing wage, then identification of such scopes provided that such scopes are known as of the time of bid solicitation;
  - i. The date and time of any pre-bid meeting(s), if any, which have been scheduled by the bidder, proposer, contractor or developer as of the bid solicitation; and

Any other information deemed relevant by the bidder, proposer, contractor or developer, as applicable, or the director to the extent the director provides written direction to the bidder, proposer, contractor or developer of such additional information at the time the goals are recommended by the director. 8. Within five (5) working days after drawing the bid specifications, send certified letters, verifiable e-mails or proof of facsimiles to certified MBEs and WBEs listed in the M/W/DBE Kansas City Mo. Online Directory.

- C. A Bidder may be required to give the City documentation to prove that it made good faith efforts. The Bidder will be contacted by the City with further instructions about when this documentation must be submitted.

#### **IX. Modification of the Contractor Utilization Plan or Substitution of an MBE/WBE.**

- A. After bid opening, a Bidder or Contractor may need to substitute an MBE and/or WBE or request that the amount of MBE/WBE participation listed in its Contractor Utilization Plan be modified. Bidder or Contractor must file a **Request for Modification or Substitution (CREO KC Form 11) prior to actual substitution and within a reasonable time after learning that a modification or substitution is necessary.** The Director may approve substitutions or modifications and upon approval, the modifications and substitutions will become an amendment to the Contractor Utilization Plan. Modifications or substitutions may be approved when:
  - 1. The Director finds that the Bidder or Contractor made and provided evidence of good faith efforts to substitute the MBE/WBE listed on the Contractor Utilization Plan with other certified MBE/WBEs for the scope of work or any other scope of work in the contract; and
  - 2. The Bidder or Contractor has not attempted intentionally to evade the requirements of the program and it is in the best interests of the City to allow a modification or substitution; and
  - 3. The Director also finds one of the following:
    - a. The listed MBE/WBE is non-responsive or cannot perform; or
    - b. The listed MBE/WBE has increased its previously quoted price to the bidder, proposer or contractor without a corresponding change in the scope of the work; or
    - c. The listed MBE/WBE has committed a material default or breach of its contract with the contractor; or
    - d. Requirements of the scope of work of the contract have changed and render subcontracting not feasible or not feasible at the levels required by the goals established for the contract; or
    - e. The listed MBE/WBE is unacceptable to the contracting department; or
    - f. The listed MBE/WBE thereafter had its certification revoked; or
- B. A modification shall not be made unless the modification or substitution has first been requested and approved by the Director. Once a modification has been made, a Construction Contractor Employee Identification Report (CREO KC Form 0485.04) for the newly approved subcontractor must be submitted at least ten (10) days prior to the approved subcontractor commencing work on a City contract.

#### **X. Appeals.**

- A. In conformance with the Act, appeals may be made to the City Fairness in Construction Board or Fairness in Professional Services and Goods Board on the following:



1. The grant or denial of a Request for Waiver;
  2. Substitution for an MBE/WBE listed on a Contractor Utilization Plan;
  3. Modification of the percentage of MBE/WBE participation on a Contractor Utilization Plan;
  4. Liquidated Damages;
  5. The amount of MBE/WBE credit the Contractor may receive for MBE/WBE participation identified in the contractor utilization plan.
- B. Any appeal must be filed in writing with the Director within fifteen (15) calendar days of notice of the determination. Mailing, faxing, personal delivery or posting at CREO KC of determinations shall constitute notice. The appeal shall state with specificity why the Bidder or Contractor believes the determination is incorrect
- C. Failure to file a timely appeal shall constitute a waiver of a Bidder's or Contractor's right to appeal such determination and such person shall be estopped to deny the validity of any determination which could have been timely appealed.

#### **XI. Access to Documents and Records.**

- A. By submitting a Bid, each Bidder agrees to permit the City, its duly authorized agents or employees, access at all reasonable times to all books and business records of Bidder as may be necessary to ascertain compliance with the requirements of this document and the Act, within ten (10) calendar days of the date of the written request.
- B. All Bidders agree to cooperate with the contracting department and CREO KC in studies and surveys regarding the MBE/WBE program.

#### **XII. Miscellaneous.**

- A. A Bidder or Contractor shall bear the burden of proof with regard to all issues on appeal.
- B. In the event of any conflict between this document and the Program, the provisions of the Program shall control. The terms used in this document are defined in the Program.
- C. Oral representations are not binding on the City.
- D. The City Council may waive the requirements of this document and the Program and award the contract to the lowest and best bidder if the City Council determines a waiver is in the best interests of the City.
- E. The Director may grant extensions of time to Bidders to submit Letters of Intent to Subcontract (CREO KC Form 00450.01).

#### **XIII. Liquidated Damages – Economic Equity & Inclusion Goals--MBE/WBE Program.**

- A. If Contractor fails to achieve the MBE/WBE goals stated in its Contractor Utilization Plan, as amended, the City will sustain damages, the exact extent of which would be difficult or impossible to ascertain. Therefore, in order to liquidate those damages, the monetary difference between either (1) the amount of the MBE/WBE goals set forth in the Contractor Utilization Plan, as amended, or (2) the goals established (whichever is lower) and the amount actually paid to qualified MBEs and WBEs for performing a commercially useful function will be deducted from the Contractor's payments as



liquidated damages. In determining the amount actually paid to qualified MBEs and WBEs, no credit will be given for the portion of participation that was not approved by the Director, unless the Director determines that the Contractor acted in good faith. No deduction for liquidated damages will be made when, for reasons beyond the control of the Contractor, the MBE/WBE participation stated in the Contractor Utilization Plan, as amended and approved by the Director is not met.

## **PART B. CONSTRUCTION EMPLOYMENT PROGRAM REQUIREMENTS**

**IMPORTANT:** This Part B is applicable to City construction contracts estimated by the City prior to solicitation as: (1) requiring more than 800 construction labor hours and (2) valued in excess of \$300,000.00. This program is distinguished from the M/WBE Program in that it is based on workforce hours of the Bidder and *all* its participating subcontractors rather than the actual contract value of work. The instructions herein detail the specifics related to this program. This program is in *addition* to the M/WBE program.

### **I. City's Construction Employment Program.**

- A. The City has adopted a Construction Employment Program (Sections 3-501 through 3-525, Code of Ordinances) (the "Workforce Program" or "Program") to implement the City's policy of supporting the fullest possible utilization of minority and women workers in the construction industry.
- B. The minimum workforce goals are currently set by ordinance at 10% for minorities and 2% for women. These goals are separate from M/WBE goals. Public recognition may be provided if the bidder achieves at least twice the minimum participation.
- C. Construction contracts subject to the Workforce Program and the company-wide and project-specific workforce goals ("workforce goals") are those contracts to construct, reconstruct, improve, enlarge or alter any fixed work that is estimated by the City prior to solicitation to: (1) require more than 800 construction labor hours, (2) has estimated costs that exceed \$300,000.00, and (3) involve the expenditure of public funds.
- D. The successful bidder may meet company-wide goals by counting the bidder's utilization of minorities and women throughout the Kansas City metropolitan statistical area. In addition, the successful Bidder is responsible to ensure that it and its subcontractors cumulatively make good faith efforts to meet project-specific goals for utilization of minorities and women.
- E. These Civil Rights & Equal Opportunity Department ("CREO KC") Forms & Instructions are part of the BIDDING DOCUMENTS and CONTRACT DOCUMENTS as defined in the General Conditions. By submitting a Bid, the Bidder agrees, as a material term of the contract, to carry out the City's Construction Employment Program by making good faith efforts to utilize minority and women workers to the fullest extent consistent with submitting the lowest and best bid to the City. Bidder agrees that the Program is incorporated into this document and agrees to follow the Program. Although it is not a requirement that a Bidder in fact meet or exceed the construction employment goals to receive approval from CREO KC, a Bidder not doing so is required to



objectively demonstrate to CREO KC that good faith efforts have been made.

- F. The following reports are to be used for Construction Employment Program submittals:
1. Project Workforce Monthly Report
  2. Company-Wide Workforce Monthly Report

## II. Required Submissions.

- A. Within forty-eight (48) hours after bid opening, the construction contractor shall submit the **Construction Employee Identification Report** (CREO KC Form 00485.04) and shall include: the name, home address, job title, sex and race/ethnicity of each person working for the Prime. The individuals to be listed on the form are those which the construction contractor *anticipates* will be performing construction labor hours creditable towards the minimum workforce goals applicable to the construction contractor individually.

The following circumstances also require the submission of a Construction Employee Identification Report:

- a. Prior to contract execution for those City construction contracts awarded pursuant to a request for proposals (RFP), the construction contractor shall submit a **Construction Employee Identification Report** (CREO KC Form 00485.04).
  - b. At least ten (10) days prior to the date upon which any subcontractor is to commence work under a City construction contract, the Prime shall submit a **Construction Employee Identification Report** (CREO KC Form 00485.04) for the subcontractor.
- B. The CREO KC Director has established the B2GNow Diversity Management System (“B2GNOW”) (an online reporting tool) as the preferred method for fulfilling reporting requirements of the Workforce Program. The CREO KC Director will allow paper submission in lieu of on-line submission if the on-line submission process presents a hardship to the contractor.
- C. Bidder must submit the following documents through B2GNow on a monthly basis if awarded the contract:
1. **Project Workforce Monthly Report.** This report is contract specific. This report must be submitted to the Director by the 15<sup>th</sup> of each month for the Contractor and each subcontractor. It will be utilized to report the Contractor’s own workforce compliance data with regard to the City’s construction contract. Failure to submit timely reports may result in delays in processing of current and future contract approvals and payment applications.
  2. **Company-Wide Workforce Monthly Report.** This report is not contract specific; it is used to report on the utilization of women and minorities, by trade, company-wide. This report must be submitted to the Director by the 15<sup>th</sup> of each month. It will be utilized to report the Contractor’s own workforce compliance data with regard to



every contract (both privately and publicly funded) that the Contractor has in progress throughout the Kansas City Metropolitan Statistical Area. Failure to submit timely reports may result in delays in processing of current and future contract approvals and payment applications.

### **III. Submittal Required for Final Contract Payment.**

- A. The final Project Workforce Monthly Report(s) and Company-Wide Workforce Monthly Report must be submitted before final payment will be made and/or retainage released. Contractor shall note the submittal of the final reports by notation in the box entitled “Final Report”

### **IV. Methods for Securing Workforce Participation and Good Faith Efforts.**

- A. A bidder is required to make good faith efforts to achieve the construction employment goals and ensure its subcontractors are making good faith efforts to achieve the construction employment goals. If a Bidder or its subcontractors will be unable to secure enough minority and female participation to meet or exceed the construction employment goals, a bidder must, within a reasonable time after so learning, request a waiver or modification of the goals by the Director of CREO KC. The Director will request evidence of the Bidder’s and its’ subcontractors’ good faith efforts to meet the goals. The Director will examine the Bidder’s request and the Bidder’s documentation of good faith efforts for itself and its subcontractors. The Director will examine the Bidder’s request and the Bidder’s documentation of good faith efforts and grant or deny a waiver or modification. The Director will grant a waiver or modification only if the Bidder has made good faith efforts to secure minority and female participation.

**IMPORTANT:** The Bidder’s subcontractors on a city construction contract must meet the workforce goals collectively. The bidder is responsible to ensure the subcontractors make good faith efforts to meet the workforce goals. Bidders are required to include language in its subcontracts that ensure the subcontractors make good faith efforts to meet or exceed the workforce goals.

- B. In evaluating good faith efforts, the Director will consider whether the Bidder and its subcontractors have performed the following:
  1. For those bidders that are not signatories to a collective bargaining agreement with organized labor:
    - a. Requested in writing the assistance of the Director with respect to efforts to promote the utilization of minorities and women in the workforce and acted upon the Director’s recommendations; and
    - b. Advertised in minority or women trade association newsletters and/or minority or women owned media at least 15 calendar days prior to the utilization of any construction services on the city construction contract and used terminology that sufficiently describes the work available, the pay scale, the application process, and anything else that one might reasonably be expected to be informed of relevant to the position being advertised; and
    - c. Maintained copies of each advertisement and a log identifying the publication and date of publication; and



- d. Conducted real and substantial recruitment efforts, both oral and written, targeting resident, minority and women community-based organization, schools with a significant minority student population, and training organizations serving the recruitment area; and
  - e. Established and maintained a current list of resident, minority and women recruitment sources, providing written notification to the recruitment sources of available employment opportunities, and maintained records of the notices submitted to the organizations and any responses thereto; and
  - f. Maintained a current file for the time period of the city construction contract with the name, address, and telephone number of each resident, minority and woman job applicant, the source of the referral, whether or not the person was hired, and in the event that the applicant was not hired, the reason therefore; and
  - g. Promoted the retention of minorities and women in its workforce with the goals of achieving sufficient annual hours for minorities and women to qualify for applicable benefits; and
  - h. Required by written contract that all subcontractors comply with the above efforts.
2. For those bidders that are signatories to collective bargaining agreements with organized labor:
- a. Requested in writing from each labor union representing crafts to be employed that:
    - i. the labor union make efforts to promote the utilization of residents of the City, minorities and women in the workforce; and
    - ii. the labor union identify any residents of the City, minorities and women in its membership eligible for employment; and
  - b. Collaborated with labor unions in promoting mentoring programs for journeypersons intended to assist minorities and women in increasing retention with the goals of achieving sufficient annual hours to qualify for applicable benefits; and
  - c. Maintained a current file with the name, address, and telephone number of each resident, minority and women worker identified by the labor union, whether or not the person was hired, and in the event the person was not hired, the reason therefore.
  - d. To the extent the good-faith efforts applicable to bidders that are signatories to collective bargaining agreements with organized labor conflict with the procedures implemented by the bidder in order to comply with the relevant bargaining agreement, the bidder shall substitute other procedures as may be approved by the Director in writing, in order to accomplish the purpose and intent of this section.

C. In the event workforce goals are not met or there is anticipation that goals will not be





met, a Bidder will be required to give the City documentation to prove that it and/or its subcontractors made good faith efforts. The Bidder will be contacted by the City with further instructions about when this documentation must be submitted.

#### **V. Access to Documents and Records.**

- A. By submitting a Bid, each Bidder agrees to permit the City, its duly authorized agents or employees, access at all reasonable times to all books and business records of Bidder as may be necessary to ascertain compliance with the requirements of this document and the Program, within ten (10) days of the date of the written request. Each bidder further agrees to require, if awarded the contract, that every subcontractor permit the City the same access to documents and records.
- B. All Bidders agree to cooperate with the contracting department and CREO KC in studies and surveys regarding the construction employment program.

#### **VI. Appeals.**

- A. In conformance with the Program, appeals may be made to the Construction Workforce Board on the following:
  - 1. Determinations by the Director that a contractor did not meet the construction employment goals and did not make a good faith effort to meet the goals;
  - 2. Recommendations by the Director to assess liquidated damages;
  - 3. Recommendation by the Director that a contractor be declared ineligible to receive any city construction contract for a period of time up to one year.
- B. Any appeal must be filed in writing with the Director within ten (10) working days of notice of the recommendation or determination. The appeal shall state with specificity why the Bidder or Contractor believes the recommendation or determination is incorrect.
- C. Failure to file a timely appeal shall constitute a waiver of a Bidder's or Contractor's right to appeal such determination or recommendation and such person shall be estopped to deny the validity of any order, determination, recommendation or action of CREO KC which could have been timely appealed.

#### **VII. Miscellaneous.**

- A. A Bidder or Contractor shall bear the burden of proof with regard to all issues on appeal.
- B. The successful bidder may be required to meet with the Director of CREO KC or the Director's designee for the purpose of discussing the construction employment program, the bidder's efforts to realize the goals, and any other problems and/or issues affecting the realization of the goals or the program in general.
- C. In the event of any conflict between this document and the Program, the provisions of the Program shall control. The terms used in this document are defined in the Program.
- D. Oral representations are not binding on the City.

#### **VIII. Failure to Meet Workforce Goals**

- A. If Contractor or its subcontractors fail to achieve the construction employment goals or make good faith efforts to achieve those goals without having previously obtained a



waiver or modification of those goals, the City will sustain damages, the exact extent of which would be difficult or impossible to ascertain. These damages are magnified if the failure to abide by the requirements of the Workforce Program is recurring. Therefore, if the directory finds that the contractor or subcontractor have not met, or made good faith efforts to meet, the construction employment goals for any quarter, the director may:

1. Assess liquidated damages against the construction contractor, as specified in the city construction contract;
2. Require the contractor to attend mandatory training, as specified in the construction contract;
3. Declare the contractor ineligible to receive any city construction contract or participate as a subcontractor under any city construction contract for a period of time up to six months, as specified in the construction contract.

#### **IX. First Source Program**

- A. The City has established a labor force recruiting program intended to assist contractors in identifying, interviewing and hiring qualified job applicants residing in Kansas City, Missouri. While the contractor awarded a City construction contract is not prohibited from hiring persons residing outside Kansas City, Missouri, the recruiting resource provided for herein (the “First Source Program”) must be utilized by the contractor subject to the construction employment goals as set forth in this **PART B, CONSTRUCTION EMPLOYMENT PROGRAM REQUIREMENTS**.
- B. The City utilizes the services of the Full Employment Council, Inc., to administer the First Source Program. The contractor shall contact the Full Employment Council within 48 hours of contract award, regardless of whether the contractor has any hiring needs at that time, and within 48 hours following any job vacancy which the contractor reasonably anticipates filling during the term of the City construction contract. The contractor shall comply with the First Source Program requirements as implemented by the Full Employment Council unless otherwise excused in writing by the Director of CREO KC for good cause shown. To ensure compliance with the First Source Program, the contractor shall contact those persons at the Full Employment Council responsible for administering the program, which may be identified by visiting their website at [www.feckc.org](http://www.feckc.org) and clicking on the link for KCMO First Source Hiring Program. The contractor shall not hire any individual to provide construction services on a City construction contract unless the contractor has met the requirements of the First Source Program.
- C. The contractor shall require that its subcontractors utilize the First Source Program to the same extent that the contractor is required to do so, and shall incorporate the requirements of this Section IX into every subcontract. Every subcontractor shall be required to contact the Full Employment Council within 48 hours of subcontract award, regardless of whether the subcontractor has any hiring needs at that time, and within 48 hours following any job vacancy which the subcontractor reasonably anticipates filling during the term of their subcontract on a City construction project.



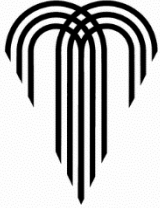

## CONTRACTOR UTILIZATION PLAN/REQUEST FOR WAIVER

Project Number \_\_\_\_\_

Project Title \_\_\_\_\_

\_\_\_\_\_  
(Department Project)

\_\_\_\_\_  
Department

\_\_\_\_\_  
(Bidder/Proposer)

STATE OF \_\_\_\_\_ )

) ss

COUNTY OF \_\_\_\_\_ )

I, \_\_\_\_\_, of lawful age and upon my oath state as follows:

1. This Affidavit is made for the purpose of complying with the provisions of the MBE/WBE submittal requirements on the above project and the MBE/WBE Program and is given on behalf of the Bidder/Proposer listed below. It sets out the Bidder/Proposer's plan to utilize MBE and/or WBE contractors on the project.
2. The project target goals are \_\_\_\_\_% MBE and \_\_\_\_\_% WBE.
3. Bidder/Proposer assures that it will utilize a minimum of the following percentages of MBE/WBE participation in the above project:

| **BIDDER/PROPOSER PARTICIPATION:** \_\_\_\_\_% MBE \_\_\_\_\_% WBE

| **POST-BID/POST-RFP ESTIMATED BUDGET:** \$ \_\_\_\_\_

4. The following are the M/WBE subcontractors whose utilization Bidder/Proposer warrants will meet or exceed the above-listed Bidder/Proposer Participation. Bidder/Proposer warrants that it will utilize the M/WBE subcontractors to provide the goods/services described in the applicable Letter(s) of Intent to Subcontract, copies of which shall collectively be deemed incorporated herein. (*All firms must currently be certified by Kansas City, Missouri*)

| Name of M/WBE Firm \_\_\_\_\_

Address \_\_\_\_\_

Telephone No. \_\_\_\_\_

I.R.S. No. \_\_\_\_\_



Name of M/WBE Firm \_\_\_\_\_  
 Address \_\_\_\_\_  
 Telephone No. \_\_\_\_\_  
 I.R.S. No. \_\_\_\_\_

Name of M/WBE Firm \_\_\_\_\_  
 Address \_\_\_\_\_  
 Telephone No. \_\_\_\_\_  
 I.R.S. No. \_\_\_\_\_

Name of M/WBE Firm \_\_\_\_\_  
 Address \_\_\_\_\_  
 Telephone No. \_\_\_\_\_  
 I.R.S. No. \_\_\_\_\_

Name of M/WBE Firm \_\_\_\_\_  
 Address \_\_\_\_\_  
 Telephone No. \_\_\_\_\_  
 I.R.S. No. \_\_\_\_\_

Name of M/WBE Firm \_\_\_\_\_  
 Address \_\_\_\_\_  
 Telephone No. \_\_\_\_\_  
 I.R.S. No. \_\_\_\_\_

*(List additional M/WBEs, if any, on additional page and attach to this form)*

4. The following is a breakdown of the percentage of the total contract amount that Bidder/Proposer agrees to pay to each listed M/WBE:

**MBE/WBE BREAKDOWN SHEET**

**MBE FIRMS:**

Name of MBE Firm	Supplier/Broker/Contractor	Subcontract Amount*	Weighted Value**	% of Total Contract
_____	_____	_____	_____	_____
_____	_____	_____	_____	_____
_____	_____	_____	_____	_____
_____	_____	_____	_____	_____
_____	_____	_____	_____	_____
_____	_____	_____	_____	_____
_____	_____	_____	_____	_____



\_\_\_\_\_

**TOTAL MBE \$ / TOTAL MBE %:** \$ \_\_\_\_\_ %

**WBE FIRMS:**

Name of WBE Firm	Supplier/Broker/Contractor	Subcontract Amount*	Weighted Value**	% of Total Contract
_____	_____	_____	_____	_____
_____	_____	_____	_____	_____
_____	_____	_____	_____	_____
_____	_____	_____	_____	_____
_____	_____	_____	_____	_____
_____	_____	_____	_____	_____
_____	_____	_____	_____	_____
_____	_____	_____	_____	_____
_____	_____	_____	_____	_____
_____	_____	_____	_____	_____
<b>TOTAL WBE \$ / TOTAL WBE %:</b>		\$ _____	_____ %	

\*“Subcontract Amount” refers to the dollar amount that Bidder/Proposer has agreed to pay each M/WBE subcontractor as of the date of contracting and is indicated here solely for the purpose of calculating the percentage that this sum represents in proportion to the total contract amount. Any contract amendments and/or change orders changing the total contract amount may alter the amount due an M/WBE under their subcontract for purposes of meeting or exceeding the Bidder/Proposer participation.

\*\*“Weighted Value” means the portion of the subcontract amount that will be credited towards meeting the Bidder/Proposer participation. See CREO KC Forms and Instructions for allowable credit and special instructions for suppliers.

- Bidder/Proposer acknowledges that the monetary amount to be paid each listed M/WBE for their work, and which is approved herein, is an amount corresponding to the percentage of the total contract amount allocable to each listed M/WBE as calculated in the MBE/WBE Breakdown Sheet. Bidder/Proposer further acknowledges that this amount may be higher than the subcontract amount listed therein as change orders and/or amendments changing the total contract amount may correspondingly increase the amount of compensation due an M/WBE for purposes of meeting or exceeding the Bidder/Proposer participation

6. Bidder/Proposer acknowledges that it is responsible for considering the effect that any change orders and/or amendments changing the total contract amount may have on its ability to meet or exceed the Bidder/Proposer participation. Bidder/Proposer further acknowledges that it is responsible for submitting a Request for Modification or Substitution if it will be unable to meet or exceed the Bidder/Proposer participation set forth herein.
7. If Bidder/Proposer has not achieved both the M/WBE goal(s) set for this Project, Bidder/Proposer hereby requests a waiver of the MBE and/or WBE goal(s) that Bidder/Proposer has failed to achieve
8. Bidder/Proposer will present documentation of its good faith efforts, a narrative summary detailing its efforts and the reasons its efforts were unsuccessful when requested by the City.
9. I hereby certify that I am authorized to make this Affidavit on behalf of the Bidder/Proposer named below and who shall abide by the terms set forth herein:

Bidder/Proposer primary contact: \_\_\_\_\_

Address: \_\_\_\_\_

Phone Number: \_\_\_\_\_

Facsimile number: \_\_\_\_\_

E-mail Address: \_\_\_\_\_

By: \_\_\_\_\_

Title: \_\_\_\_\_

Date: \_\_\_\_\_

(Attach corporate seal if applicable)

Subscribed and sworn to before me this \_\_\_\_\_ day of \_\_\_\_\_, 20\_\_\_\_.

My Commission Expires: \_\_\_\_\_

\_\_\_\_\_  
Notary Public



**Civil Rights & Equal Opportunity Department  
Economic Equity & Inclusion  
Contractor Utilization Plan Approval Form**

**Date:** 10.11.2023  
**Form Prepared By:** Leona Walton

Contract/Project Number: 9829/80002486	Developer/Prime: Infrastructure Solutions, LLC
Project Name: Emergency Water Distribution System Repairs	Contact Information: Jason Conklin/jconklin@i-solutionsllc.com/913.492.0400
Final Contract Value: \$2,700,000.00	Address: 9801 Renner Blvd, Lenexa, KS 66219

Funding:  City  State  Federal  CO-OP  Grant:  Other:

Project Requirements:  M/WBE  DBE  Section 3  N/A

Tax Incentive:  LCRA  TIF  PIEA  N/A  Other:

Prevailing Wage:  Yes  No

Davis-Bacon:  Yes  No

Construction Employment Program:  Yes: Workforce goals are 10% Minority & 2% Women. There are over 800 Workforce hours and project cost is \$300,000 or more.  
 No: Workforce hours are less than 800 and project cost is less than \$300,000.

Contract Goals:	Contractor Utilization Plan Achievement:
Self-Perform: <u>  yes  </u> %	Self-Perform: <u>  yes  </u> %
MBE: <u>  11  </u> %	MBE: <u>  11  </u> %
WBE: <u>  11  </u> %	WBE: <u>  11  </u> %
Non-certified firms: <u>  yes  </u> %	Non-certified firms: <u>  yes  </u> %

Contract Type:

Construction  Design-Build  Design Professional  Professional Services

General Service  Concession  Other Goods & Services  Non-Municipal Agency

Co-Operative  Revenue Sharing  Facilities Maintenance/Repair/Renovation

Other:

Additional Information:  
KC Water PM: Jason Wright/Jason.Wright@kcmo.org/816.513.4772

This is a construction project.

**This document is submitted with all available facts. Intentionally falsifying this document or omitting pertinent facts is grounds for disciplinary action pursuant to KCMO Human Resources Rules & Policy Manual (eff. August 4, 2014).**

**FOR CIVIL RIGHTS & EQUAL OPPORTUNITY DEPARTMENT (CREO) USE ONLY:**

**The Contractor Utilization Plan is:**

Approved  Disapproved

  11   % MBE   11   % WBE            % DBE

**The Request for Good Faith Efforts Waiver is:**

Approved  Disapproved  Not Applicable

**Appeal Sent to FICB or Incentive Agency?**  Yes            FICB            Incentive Agency  No

CREO Signature: Mark Runge Date: 10/18/2023  
6AFEC964B03641A

**Comments:**

Contractor Utilization Plan (CUP) MUST be submitted to CREO prior to being posted on docket for review & approval from Council.



**Civil Rights & Equal Opportunity Department  
Economic Equity & Inclusion  
Nondiscrimination & Equal Opportunity Review Form**

**Date:** 10.11.2023  
**Form Prepared By:** Leona Walton

Contract/Project Number: 9829/80002486	Project Name: Emergency Water Distribution System Repairs
Developer/Prime: Infrastructure Solutions, LLC	Contact Information: Jason Conklin/jconklin@i-solutionsllc.com/913.492.0400
Final Contract Value: \$2,700,000.00	Project Manager: Jason Wright/Jason.Wright@kcmo.org/816.513.4772

Funding:  City  State  Federal  CO-OP  Grant:  Other:

Project Requirements:  M/WBE  DBE  Section 3  N/A

Tax Incentive:  LCRA  TIF  PIEA  Ch. 100  Other:  N/A

Prevailing Wage:  Yes  No

Davis-Bacon:  Yes  No

Construction Employment Program:  Yes: Workforce goals are 10% Minority & 2% Women. There are over 800 Workforce hours and project cost is \$300,000 or more.  
 No: Workforce hours are less than 800 and project cost is less than \$300,000.

Contracts & Leases	Nondiscrimination
Ch. 3 Article IV: <u>yes</u>	Ch. 38: <u>yes</u>
RSMo 213: <u>yes</u>	Title VI: <u>yes</u>
MWDBE: <u>yes</u>	Prevailing Wage and Labor Standards: <u>yes</u>
SLBE: <u>n/a</u>	RSMo 34 Anti-Discrimination Against Israel: <u>yes</u>

Contract Type:

Construction  Design-Build  Design Professional  Professional Services

General Service  Concession  Other Goods & Services  Non-Municipal Agency

Co-Operative  Revenue Sharing  Facilities Maintenance/Repair/Renovation

Other:

Additional Information:  
KC Water PM: Jason Wright/Jason.Wright@kcmo.org/816.513.4772

This is a construction project.

**This document is submitted with all available facts. Intentionally falsifying this document or omitting pertinent facts is grounds for disciplinary action pursuant to KCMO Human Resources Rules & Policy Manual (eff. August 4, 2014).**

**FOR CIVIL RIGHTS & EQUAL OPPORTUNITY DEPARTMENT (CREO) USE ONLY:**

**The Document is:**

Approved  Disapproved

Changes Needed:

**Federal Provisions Included:**

Approved  Disapproved  Not Applicable

CREO Signature: Mark Runge Date: 10/18/2023

DocuSigned by: 6AFEC964B03641A...

**Comments:** CREO Assurances to be attached to contract.



## **Civil Rights and Equal Opportunity Department Civil Rights and Wage Assurances**

---

**Non-discrimination in Employment.** Contractor shall not discriminate against any employee or candidate for employment on the basis of an individual's race, hair texture or hair style associated with an individual's race, color, sex, religion, national origin, or ancestry, disability, sexual orientation, gender identity, age, or in any other manner prohibited by Chapter 38 of the City Code. Contractor shall not engage in any discrimination as prohibited by Chapter 3 of the City Code.

**Ban the Box in Hiring and Promotion.**

(a) Pursuant to Section 38-104, City Code Ordinances, Contractor shall not base a hiring or promotional decision on an applicant's criminal history or sentence related thereto, unless the employer can demonstrate that the employment-related decision was based on all information available including consideration of the frequency, recentness and severity of a criminal record and that the record was reasonably related to the duties and responsibilities of the position.

(b) Notwithstanding subsection (a), Contractor may inquire about an applicant's criminal history after it has been determined that the individual is otherwise qualified for the position, and only after the applicant has been interviewed for the position. Any such inquiry may be made of all applicants who are within the final selection pool of candidates from which a job will be filled.

(c) This provision shall not apply to positions where employers are required to exclude applicants with certain criminal convictions from employment due to local, state or federal law or regulation.

**Title VI of the Civil Rights Act of 1964.** Title VI of the Civil Rights Act of 1964 requires that no person in the United States shall, on the grounds of race, color, or national or origin (including limited English proficient individuals), be excluded from participation in, be denied the benefits of, or be subjected to discrimination under any program or activity receiving federal financial assistance. The City of Kansas City, Missouri requires compliance with the requirements of Title VI in all of its programs and activities regardless of the funding source.

Contractor shall not discriminate on the grounds of race, color, or national or origin (including limited English proficient individuals).

**Quality Services Assurance Act.** If this Contract exceeds \$160,000.00, Contractor certifies Contractor will pay all employees who will work on this Contract in the city limits of Kansas City, Missouri at least \$15.00 per hour in compliance with the City's Quality Services Assurance Act,



## **Civil Rights and Equal Opportunity Department Civil Rights and Wage Assurances**

---

Section 3-66, Code of Ordinances or City has granted Contractor an exemption pursuant to the Quality Services Assurance Act.

**Anti-Discrimination Against Israel.** If this Contract exceeds \$100,000.00 and Contractor employs at least ten employees, pursuant to Section 34.600, RSMo., by executing this Contract, Contractor certifies it is not currently engaged in and shall not, for the duration of this contract, engage in a boycott of goods or services from the State of Israel; companies doing business in or with Israel or authorized by, licensed by, or organized under the laws of the State of Israel; or persons or entities doing business in the State of Israel.

**Affirmative Action.** If this Contract exceeds \$300,000.00 and Contractor employs fifty (50) or more people, Contractor shall comply with City's Affirmative Action requirements in accordance with the provisions of Chapter 3 of City's Code, the rules and regulations relating to those sections, and any additions or amendments thereto; in executing any Contract subject to said provisions, Contractor warrants that it has an affirmative action program in place and will maintain the affirmative action program in place for the duration of the Contract. Contractor shall not discriminate against any employee or applicant for employment because of race, color, sex, religion, national origin or ancestry, disability, sexual orientation, gender identity or age in a manner prohibited by Chapter 3 of City's Code. Contractor shall:

- (a) Execute and submit the City of Kansas City, Missouri CREO Affirmative Action Program Affidavit warranting that the Contractor has an affirmative action program in place and will maintain the affirmative action program in place for the duration of the Contract.
- (b) Submit, in print or electronic format, a copy of Contractor's current certificate of compliance to the City's Civil Rights and Equal Opportunity Department (CREO) prior to receiving the first payment under the Contract, unless a copy has already been submitted to CREO at any point within the previous two (2) calendar years. If, and only if, Contractor does not possess a current certification of compliance, Contractor shall submit, in print or electronic format, a copy of its affirmative action program to CREO prior to receiving the first payment under the Contract, unless a copy has already been submitted to CREO at any point within the previous two (2) calendar years.
- (c) Require any Subcontractor awarded a subcontract exceeding \$300,000.00 to affirm that Subcontractor has an affirmative action program in place and will maintain the affirmative action program in place for the duration of the subcontract.
- (d) Obtain from any Subcontractor awarded a subcontract exceeding \$300,000.00 a copy of the Subcontractor's current certificate of compliance and tender a copy of the same, in print or



## **Civil Rights and Equal Opportunity Department Civil Rights and Wage Assurances**

---

electronic format, to CREO within thirty (30) days from the date the subcontract is executed. If, and only if, Subcontractor does not possess a current certificate of compliance, Contractor shall obtain a copy of the Subcontractor's affirmative action program and tender a copy of the same, in print or electronic format, to CREO within thirty (30) days from the date the subcontract is executed.

City has the right to take action as directed by City's Civil Rights and Equal Opportunity Department to enforce this provision. If Contractor fails, refuses or neglects to comply with the provisions of Chapter 3 of City's Code, then such failure shall be deemed a total breach of this Contract and this Contract may be terminated, cancelled or suspended, in whole or in part, and Contractor may be declared ineligible for any further contracts funded by City for a period of one (1) year. This is a material term of this Contract.

**Compliance with Laws.** Contractor shall comply with all federal, state and local laws, ordinances and regulations applicable to the work and this Agreement. Contractor shall maintain in effect all the licenses, permissions, authorizations, consents and permits that it needs to carry out its obligations under this Agreement.

**Prevailing Wage.** If the Agreement exceeds \$75,000.00 and any of the Services performed by Contractor includes construction, reconstruction, improvement, enlargement, alteration, painting and decorating, or major repair, that is subject to the Missouri Prevailing Wage Law (Section 290.210, RSMo – 290.340, RSMo), Contractor shall immediately notify the City prior to performing Services so the parties can execute an agreement that incorporates, the appropriate Wage Order. Contractor shall comply with all requirements of Section 290.210, RSMo – 290.340, RSMo even if Contractor fails to notify the City.



# LETTER OF INTENT TO SUBCONTRACT

Check one:	
Original LOI:	<input type="checkbox"/>
Updated LOI:	<input type="checkbox"/>

Project Name/Title \_\_\_\_\_  
 Project Location/Number \_\_\_\_\_

**PART I:** Prime Contractor \_\_\_\_\_ agrees to enter into a contractual agreement with M/W/DBE Subcontractor \_\_\_\_\_ who will provide the following goods/services in connection with the above-reference contract: [Insert a brief narrative describing goods/services to be provided. Broad Categorizations (e.g., "electrical," "plumbing," etc.) or the listing of NAICS Codes in which M/W/DBE Subcontractor is certified are insufficient and may result in denial of this Letter of Intent to Subcontract.]

for an estimated amount of \$ \_\_\_\_\_ (or \_\_\_\_\_ % of the total estimated contract value.)

- M/WBE Vendor type:
- Subcontractor/manufacturer (counts as 100% of contract value towards goals)
  - Supplier (counts as 60% of the total dollar amount paid or to be paid by a prime contractor for supplies or goods towards goals)
  - Broker (counts as 10% of the total dollar amount paid or to be paid by a prime contractor for supplies or goods towards goals)

M/W/DBE Subcontractor is, to the best of Prime Contractor's knowledge, currently certified with the City of Kansas City's Civil Rights & Equal Opportunity Department to perform in the capacities indicated herein. Prime Contractor agrees to utilize M/W/DBE Subcontractor in the capacities indicated herein, and M/W/DBE Subcontractor agrees to work on the above-referenced contract in the capacities indicated herein, contingent upon award of the contract to Prime Contractor.

**PART 2:** This section is to be completed by the M/W/DBE subcontractor listed above. Please attach additional sheets as needed for more than one intended sub-tier contract. **IMPORTANT: Falsification of this document will result in denial and other remedies available under City Code.**

- Select one:
- The M/W/DBE Subcontractor listed above **IS NOT** subcontracting any portions of the above-stated scope of work(s). (Continue to Part 3.)
  - The M/W/DBE Subcontractor listed above **IS** subcontracting certain portions of the above stated scope of work(s) to:

(1) Company name: \_\_\_\_\_

Full address: \_\_\_\_\_  
Street number and name City, State and Zip Code

Primary contact: \_\_\_\_\_  
Name Phone

a) This subcontractor is (select one):    MBE    WBE    DBE    N/A

- i: If this subcontractor is an M/W/DBE certified with the City of Kansas City, Missouri, a separate Letter of Intent must be attached to this document.
- ii. If this subcontractor is NOT a certified M/W/DBE certified with the City of Kansas City, Missouri, the firm must still be listed for reporting purposes but a Letter of Intent is not required.

b) Scope of work to be performed: \_\_\_\_\_

c) The dollar value of this agreement is: \_\_\_\_\_







# LETTER OF INTENT TO SUBCONTRACT

Check one:  
 Original LOI:   
 Updated LOI:

Project Name/Title Emergency Water Distribution System Repair  
 Project Location/Number 800 2486-9829

**PART I:** Prime Contractor Infrastructure Solutions agrees to enter into a contractual agreement with M/W/DBE Subcontractor Boswell & Lee who will provide the following goods/services in connection with the above-reference contract: [Insert a brief narrative describing goods/services to be provided. Broad Categorizations (e.g., "electrical," "plumbing," etc.) or the listing of NAICS Codes in which M/W/DBE Subcontractor is certified are insufficient and may result in denial of this Letter of Intent to Subcontract.]

Trucking

for an estimated amount of \$ 15,000 (or \_\_\_\_\_ % of the total estimated contract value.)

- M/WBE Vendor type:
- Subcontractor/manufacturer (counts as 100% of contract value towards goals)
  - Supplier (counts as 60% of the total dollar amount paid or to be paid by a prime contractor for supplies or goods towards goals)
  - Broker (counts as 10% of the total dollar amount paid or to be paid by a prime contractor for supplies or goods towards goals)

M/W/DBE Subcontractor is, to the best of Prime Contractor's knowledge, currently certified with the City of Kansas City's Civil Rights & Equal Opportunity Department to perform in the capacities indicated herein. Prime Contractor agrees to utilize M/W/DBE Subcontractor in the capacities indicated herein, and M/W/DBE Subcontractor agrees to work on the above-referenced contract in the capacities indicated herein, contingent upon award of the contract to Prime Contractor.

**PART 2:** This section is to be completed by the M/W/DBE subcontractor listed above. Please attach additional sheets as needed for more than one intended sub-tier contract. **IMPORTANT: Falsification of this document will result in denial and other remedies available under City Code.**

- Select one:
- The M/W/DBE Subcontractor listed above **IS NOT** subcontracting any portions of the above-stated scope of work(s). (Continue to Part 3.)
  - The M/W/DBE Subcontractor listed above **IS** subcontracting certain portions of the above stated scope of work(s) to:

(1) Company name: \_\_\_\_\_

Full address: \_\_\_\_\_

Street number and name City, State and Zip Code

Primary contact: \_\_\_\_\_

Name Phone

a) This subcontractor is (select one):  MBE  WBE  DBE  N/A

i: If this subcontractor is an M/W/DBE certified with the City of Kansas City, Missouri, a separate Letter of Intent must be attached to this document.

ii. If this subcontractor is NOT a certified M/W/DBE certified with the City of Kansas City, Missouri, the firm must still be listed for reporting purposes but a Letter of Intent is not required.

b) Scope of work to be performed: \_\_\_\_\_

c) The dollar value of this agreement is: \_\_\_\_\_



**PART 3:**

**NOTE: SIGNATURES AND NOTARIZATIONS REQUIRED FOR NEW LETTERS OF INTENT (LOI);  
SIGNATURES ONLY FOR UPDATED LOI (ADDING VALUE TO EXISTING CONTRACT).**

PRIME CONTRACTOR BUSINESS NAME: Infrastructure Solutions LLC

[Signature]  
Signature: Prime Contractor

Nate Morgan  
Print Name

Project Manager  
Title

09/25/2024  
Date

State of Kansas )  
County of Johnson )

I, Aaron Marie Money, state that the above and foregoing is based on my best knowledge and belief.

Subscribed and sworn to before me, a notary public, on this 25<sup>th</sup> day of Sept, 2024

My Commission Expires: 02/23/2027

Aaron Marie Money  
Notary Public

STAMP:

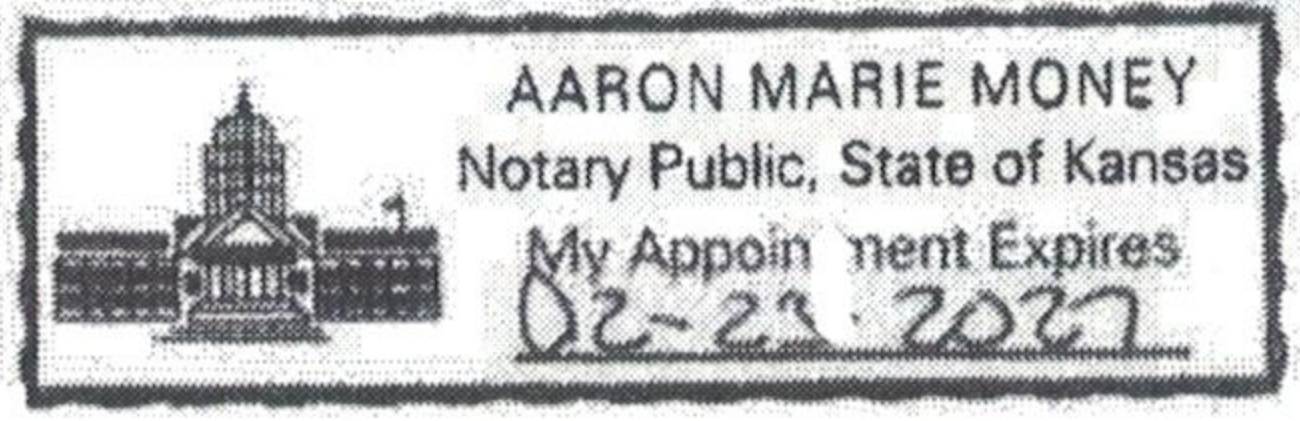

MWDBE SUBCONTRACTOR BUSINESS NAME: Boswell & Lee Trucking

[Signature]  
Signature: Subcontractor

Clarence Boswell  
Print Name

Owner/President  
Title

9/25/24  
Date

State of Kansas )  
County of Wyandotte )

I, Clarence Boswell, state that the above and foregoing is based on my best knowledge and belief.

Subscribed and sworn to before me, a notary public, on this 25<sup>th</sup> day of Sept, 2024

My Commission Expires: \_\_\_\_\_

Nancy Waldrup  
Notary Public

STAMP:

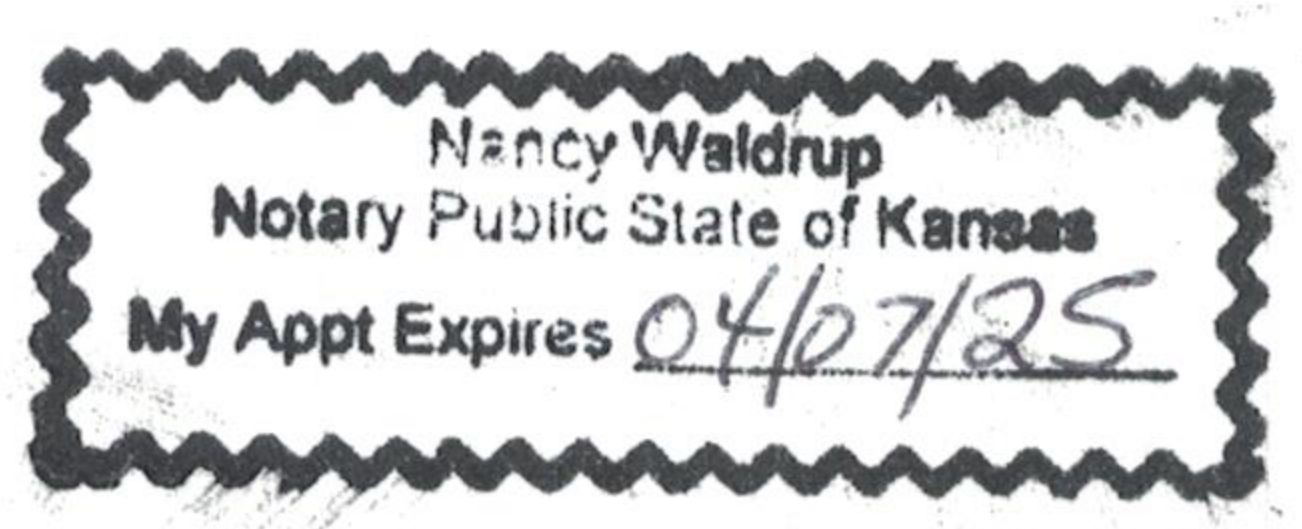



# LETTER OF INTENT TO SUBCONTRACT

Check one:

Original LOI:

Updated LOI:

Project Name/Title Emergency Water Distribution System Repairs

Project Location/Number 80002486 / 9829

**PART 1:** Prime Contractor Infrastructure Solutions, LLC agrees to enter into a contractual agreement with M/W/DBE Subcontractor Petro Trucking who will provide the following goods/services in connection with the above-reference contract: [Insert a brief narrative describing goods/services to be provided. Broad Categorizations (e.g., "electrical," "plumbing," etc.) or the listing of NAICS Codes in which M/W/DBE Subcontractor is certified are insufficient and may result in denial of this Letter of Intent to Subcontract.]

Petro trucking will be hauling off all spoils from the emergency repair sites and hauling in new aggregate for bedding and backfill.

for an estimated amount of \$ 264,000.00 of 2,400,00.00 (or 11 % of the total estimated contract value.)

- M/WBE Vendor type:
- Subcontractor/manufacturer (counts as 100% of contract value towards goals)
  - Supplier (counts as 60% of the total dollar amount paid or to be paid by a prime contractor for supplies or goods towards goals)
  - Broker (counts as 10% of the total dollar amount paid or to be paid by a prime contractor for supplies or goods towards goals)

M/W/DBE Subcontractor is, to the best of Prime Contractor's knowledge, currently certified with the City of Kansas City's Civil Rights & Equal Opportunity Department to perform in the capacities indicated herein. Prime Contractor agrees to utilize M/W/DBE Subcontractor in the capacities indicated herein, and M/W/DBE Subcontractor agrees to work on the above-referenced contract in the capacities indicated herein, contingent upon award of the contract to Prime Contractor.

**PART 2:** This section is to be completed by the M/W/DBE subcontractor listed above. Please attach additional sheets as needed for more than one intended sub-tier contract. **IMPORTANT: Falsification of this document will result in denial and other remedies available under City Code.**

- Select one:
- The M/W/DBE Subcontractor listed above **IS NOT** subcontracting any portions of the above-stated scope of work(s). (Continue to Part 3.)
  - The M/W/DBE Subcontractor listed above **IS** subcontracting certain portions of the above stated scope of work(s) to:

(1) Company name: Petro Trucking Co

Full address: 6028 Cleveland Ave, Kansas City, KS

Street number and name	City, State and Zip Code
Primary contact: <u>Nancy Waldrup</u>	<u>913-299-2014</u>

Name	Phone
------	-------

a) This subcontractor is (select one):  MBE  WBE  DBE  N/A

i: If this subcontractor is an M/W/DBE certified with the City of Kansas City, Missouri, a separate Letter of Intent must be attached to this document.

ii. If this subcontractor is NOT a certified M/W/DBE certified with the City of Kansas City, Missouri, the firm must still be listed for reporting purposes but a Letter of Intent is not required.

b) Scope of work to be performed: Haul off spoils, trucking, hauling of aggregate

c) The dollar value of this agreement is: 264,000.00



**PART 3:**

**NOTE: SIGNATURES AND NOTARIZATIONS REQUIRED FOR NEW LETTERS OF INTENT (LOI);  
SIGNATURES ONLY FOR UPDATED LOI (ADDING VALUE TO EXISTING CONTRACT).**

PRIME CONTRACTOR BUSINESS NAME: Infrastructure Solutions, LLC.

Nate Morgan  
Signature: Prime Contractor  
Project Manager  
Title

Nate Morgan  
Print Name  
08/05/2024  
Date

State of KANSAS )  
County of JOHNSON )

I, HEIDI HULLMAN-DAVIS, state that the above and foregoing is based on my best knowledge and belief.

Subscribed and sworn to before me, a notary public, on this 5<sup>th</sup> day of August, 2024

My Commission Expires: 2/5/2028

Heidi Hullman  
Notary Public

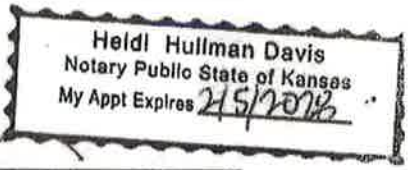

STAMP:

MWDBE SUBCONTRACTOR BUSINESS NAME: Petro Trucking Co Inc.

Nancy Waldrop  
Signature: Subcontractor  
V-Pres.  
Title

Nancy Waldrop  
Print Name  
8/6/24  
Date

State of Kansas )  
County of Johnson )

I, Brian Miller, state that the above and foregoing is based on my best knowledge and belief.

Subscribed and sworn to before me, a notary public, on this 5<sup>th</sup> day of August, 2024

My Commission Expires: February 1, 2027

Brian Miller  
Notary Public



STAMP:



# LETTER OF INTENT TO SUBCONTRACT

Check one:	
Original LOI:	<input type="checkbox"/>
Updated LOI:	<input type="checkbox"/>

Project Name/Title Emergency Water Distribution System Repairs

Project Location/Number 80002486 / 9829

**PART I:** Prime Contractor Infrastructure Solutions, LLC agrees to enter into a contractual agreement with **M/W/DBE** Subcontractor Tenoch Construction who will provide the following goods/services in connection with the above-reference contract: [Insert a brief narrative describing goods/services to be provided. Broad Categorizations (e.g., "electrical," "plumbing," etc.) or the listing of NAICS Codes in which M/W/DBE Subcontractor is certified are insufficient and may result in denial of this Letter of Intent to Subcontract.]  
Concrete Flat work, curb restoration and sidewalk repair

for an estimated amount of \$ 264,000.00 of 2,400,00.00 (or 11 % of the total estimated contract value.)

- M/WBE Vendor type:
- Subcontractor/manufacturer (counts as 100% of contract value towards goals)
  - Supplier (counts as 60% of the total dollar amount paid or to be paid by a prime contractor for supplies or goods towards goals)
  - Broker (counts as 10% of the total dollar amount paid or to be paid by a prime contractor for supplies or goods towards goals)

M/W/DBE Subcontractor is, to the best of Prime Contractor's knowledge, currently certified with the City of Kansas City's Civil Rights & Equal Opportunity Department to perform in the capacities indicated herein. Prime Contractor agrees to utilize M/W/DBE Subcontractor in the capacities indicated herein, and M/W/DBE Subcontractor agrees to work on the above-referenced contract in the capacities indicated herein, contingent upon award of the contract to Prime Contractor.

**PART 2:** This section is to be completed by the M/W/DBE subcontractor listed above. Please attach additional sheets as needed for more than one intended sub-tier contract. **IMPORTANT: Falsification of this document will result in denial and other remedies available under City Code.**

- Select one:
- The M/W/DBE Subcontractor listed above **IS NOT** subcontracting any portions of the above-stated scope of work(s). (Continue to Part 3.)
  - The M/W/DBE Subcontractor listed above **IS** subcontracting certain portions of the above stated scope of work(s) to:

(1) **Company name:** Tenoch Construction Inc.

**Full address:** 912 Scott Ave, Kansas City, KS

<b>Street number and name</b>	<b>City, State and Zip Code</b>
<u>Kurt Bowers</u>	<u>913-671-7706</u>

**Primary contact:** \_\_\_\_\_

a) This subcontractor is (select one):  MBE  WBE  DBE  N/A

i: If this subcontractor is an M/W/DBE certified with the City of Kansas City, Missouri, a separate Letter of Intent must be attached to this document.

ii. If this subcontractor is NOT a certified M/W/DBE certified with the City of Kansas City, Missouri, the firm must still be listed for reporting purposes but a Letter of Intent is not required.

b) **Scope of work to be performed:** Concrete Flatwork as applicable

c) **The dollar value of this agreement is:** 264,000.00



**PART 3:**

**NOTE: SIGNATURES AND NOTARIZATIONS REQUIRED FOR NEW LETTERS OF INTENT (LOI);  
SIGNATURES ONLY FOR UPDATED LOI (ADDING VALUE TO EXISTING CONTRACT).**

PRIME CONTRACTOR BUSINESS NAME: Infrastructure Solutions, LLC.

Nate Morgan  
Signature: Prime Contractor  
Project Manager  
Title

Nate Morgan  
Print Name  
08/05/2024  
Date

State of KANSAS )  
County of JOHNSON )

I, HEIDI HULLMAN-DAVIS, state that the above and foregoing is based on my best knowledge and belief.

Subscribed and sworn to before me, a notary public, on this 5th day of August, 2024

My Commission Expires: 2/5/2028

Heidi Hullman Davis  
Notary Public



STAMP:

MWD BE SUBCONTRACTOR BUSINESS NAME: Tenoch Construction, Inc.

Sonya Segura Ulrich  
Signature: Subcontractor  
President  
Title

Sonya Segura Ulrich  
Print Name  
8/5/2024  
Date

State of Kansas )  
County of Wyandotte )

I, Kurt D. Bowers, state that the above and foregoing is based on my best knowledge and belief.

Subscribed and sworn to before me, a notary public, on this 5th day of Aug, 2024

My Commission Expires: 08-24-2024

Kurt D Bowers  
Notary Public

STAMP:

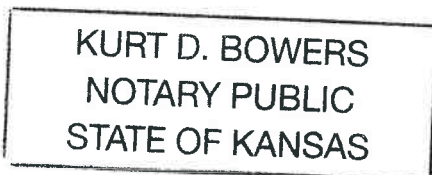



# LETTER OF INTENT TO SUBCONTRACT

Check one:	
Original LOI:	<input type="checkbox"/>
Updated LOI:	<input type="checkbox"/>

Project Name/Title Emergency Water Distribution System Repairs

Project Location/Number 80002486 / 9829

**PART 1:** Prime Contractor Infrastructure Solutions, LLC agrees to enter into a contractual agreement with M/W/DBE Subcontractor Petro Trucking who will provide the following goods/services in connection with the above-reference contract: [Insert a brief narrative describing goods/services to be provided. Broad Categorizations (e.g., "electrical," "plumbing," etc.) or the listing of NAICS Codes in which M/W/DBE Subcontractor is certified are insufficient and may result in denial of this Letter of Intent to Subcontract.]  
Petro trucking will be hauling off all spoils from the emergency repair sites and hauling in new aggregate for bedding and backfill.

for an estimated amount of \$ 264,000.00 of 2,400,00.00 (or 11 % of the total estimated contract value.)

- M/WBE Vendor type:
- Subcontractor/manufacturer (counts as 100% of contract value towards goals)
  - Supplier (counts as 60% of the total dollar amount paid or to be paid by a prime contractor for supplies or goods towards goals)
  - Broker (counts as 10% of the total dollar amount paid or to be paid by a prime contractor for supplies or goods towards goals)

M/W/DBE Subcontractor is, to the best of Prime Contractor's knowledge, currently certified with the City of Kansas City's Civil Rights & Equal Opportunity Department to perform in the capacities indicated herein. Prime Contractor agrees to utilize M/W/DBE Subcontractor in the capacities indicated herein, and M/W/DBE Subcontractor agrees to work on the above-referenced contract in the capacities indicated herein, contingent upon award of the contract to Prime Contractor.

**PART 2:** This section is to be completed by the M/W/DBE subcontractor listed above. Please attach additional sheets as needed for more than one intended sub-tier contract. **IMPORTANT: Falsification of this document will result in denial and other remedies available under City Code.**

- Select one:
- The M/W/DBE Subcontractor listed above **IS NOT** subcontracting any portions of the above-stated scope of work(s). (Continue to Part 3.)
  - The M/W/DBE Subcontractor listed above **IS** subcontracting certain portions of the above stated scope of work(s) to:

(1) Company name: Petro Trucking Co

Full address: 6028 Cleveland Ave, Kansas City, KS

Street number and name	City, State and Zip Code
Primary contact: <u>Nancy Waldrup</u>	<u>913-299-2014</u>

Name \_\_\_\_\_ Phone \_\_\_\_\_

a) This subcontractor is (select one):  MBE  WBE  DBE  N/A

i: If this subcontractor is an M/W/DBE certified with the City of Kansas City, Missouri, a separate Letter of Intent must be attached to this document.

ii. If this subcontractor is NOT a certified M/W/DBE certified with the City of Kansas City, Missouri, the firm must still be listed for reporting purposes but a Letter of Intent is not required.

b) Scope of work to be performed: Haul off spoils, trucking, hauling of aggregate

c) The dollar value of this agreement is: 264,000.00

**PART 3:**

**NOTE: SIGNATURES AND NOTARIZATIONS REQUIRED FOR NEW LETTERS OF INTENT (LOI);  
SIGNATURES ONLY FOR UPDATED LOI (ADDING VALUE TO EXISTING CONTRACT).**

PRIME CONTRACTOR BUSINESS NAME: Infrastructure Solutions, LLC.

Nate Morgan  
Signature: Prime Contractor  
Project Manager  
Title

Nate Morgan  
Print Name  
08/05/2024  
Date

State of KANSAS )  
County of JOHNSON )

I, HEIDI HULLMAN-DAVIS, state that the above and foregoing is based on my best knowledge and belief.

Subscribed and sworn to before me, a notary public, on this 5<sup>th</sup> day of August, 2024

My Commission Expires: 2/5/2028

Heidi Hullman  
Notary Public

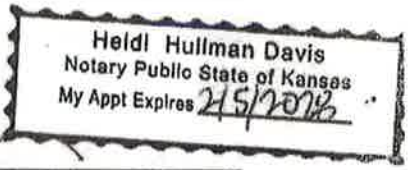

STAMP:

MWDBE SUBCONTRACTOR BUSINESS NAME: Petro Trucking Co Inc.

Nancy Waldrop  
Signature: Subcontractor  
V-Pres.  
Title

Nancy Waldrop  
Print Name  
8/6/24  
Date

State of Kansas )  
County of Johnson )

I, Brian Miller, state that the above and foregoing is based on my best knowledge and belief.

Subscribed and sworn to before me, a notary public, on this 5<sup>th</sup> day of August, 2024

My Commission Expires: February 1, 2027

Brian Miller  
Notary Public



STAMP:





# LETTER OF INTENT TO SUBCONTRACT

Check one:
Original LOI: <input type="checkbox"/>
Updated LOI: <input type="checkbox"/>

Project Name/Title Emergency Water Distribution System  
repairs

Project Location/Number 80002486-9829

**PART 1:** Prime Contractor Infrastructure Solutions agrees to enter into a contractual agreement with M/W/DBE Subcontractor Welch who will provide the following goods/services in connection with the above-reference contract: [Insert a brief narrative describing goods/services to be provided. Broad Categorizations (e.g., "electrical," "plumbing," etc.) or the listing of NAICS Codes in which M/W/DBE Subcontractor is certified are insufficient and may result in denial of this Letter of Intent to Subcontract.]

Erosion Control + Restoration

for an estimated amount of \$ 10,000 (or \_\_\_\_\_ % of the total estimated contract value.)

- M/WBE Vendor type:
- Subcontractor/manufacturer (counts as 100% of contract value towards goals)
  - Supplier (counts as 60% of the total dollar amount paid or to be paid by a prime contractor for supplies or goods towards goals)
  - Broker (counts as 10% of the total dollar amount paid or to be paid by a prime contractor for supplies or goods towards goals)

M/W/DBE Subcontractor is, to the best of Prime Contractor's knowledge, currently certified with the City of Kansas City's Civil Rights & Equal Opportunity Department to perform in the capacities indicated herein. Prime Contractor agrees to utilize M/W/DBE Subcontractor in the capacities indicated herein, and M/W/DBE Subcontractor agrees to work on the above-referenced contract in the capacities indicated herein, contingent upon award of the contract to Prime Contractor.

**PART 2:** This section is to be completed by the M/W/DBE subcontractor listed above. Please attach additional sheets as needed for more than one intended sub-tier contract. **IMPORTANT: Falsification of this document will result in denial and other remedies available under City Code.**

- Select one:
- The M/W/DBE Subcontractor listed above **IS NOT** subcontracting any portions of the above-stated scope of work(s). (Continue to Part 3.)
  - The M/W/DBE Subcontractor listed above **IS** subcontracting certain portions of the above stated scope of work(s) to:

(1) Company name: \_\_\_\_\_

Full address: \_\_\_\_\_

Street number and name City, State and Zip Code

Primary contact: \_\_\_\_\_

Name Phone

a) This subcontractor is (select one):  MBE  WBE  DBE  N/A

i: If this subcontractor is an M/W/DBE certified with the City of Kansas City, Missouri, a separate Letter of Intent must be attached to this document.

ii. If this subcontractor is NOT a certified M/W/DBE certified with the City of Kansas City, Missouri, the firm must still be listed for reporting purposes but a Letter of Intent is not required.

b) Scope of work to be performed: \_\_\_\_\_

c) The dollar value of this agreement is: \_\_\_\_\_



**PART 3:**

**NOTE: SIGNATURES AND NOTARIZATIONS REQUIRED FOR NEW LETTERS OF INTENT (LOI);  
SIGNATURES ONLY FOR UPDATED LOI (ADDING VALUE TO EXISTING CONTRACT).**

PRIME CONTRACTOR BUSINESS NAME: Infrastructure Solutions LLC

[Signature]  
Signature, Prime Contractor

Nate Morgan  
Print Name

Project Manager  
Title

09/25/2024  
Date

State of Kansas )

County of Johnson )

I, Aaron Marie Money, state that the above and foregoing is based on my best knowledge and belief.

Subscribed and sworn to before me, a notary public, on this 25<sup>th</sup> day of Sept, 2024

My Commission Expires: 02/23/2027

Aaron Marie Money  
Notary Public

STAMP:



MWDBE SUBCONTRACTOR BUSINESS NAME: Welch Silt Fence + Erosion Control, LLC

[Signature]  
Signature, Subcontractor

Daniel Welch  
Print Name

Managing Member  
Title

9/25/24  
Date

State of Missouri )

County of Cass )

I, Jessica Ekster, state that the above and foregoing is based on my best knowledge and belief.

Subscribed and sworn to before me, a notary public, on this 25<sup>th</sup> day of September 2024

My Commission Expires: 11/18/2024

Jessica Ekster  
Notary Public

STAMP:

**JESSICA DENISE EKSTER**  
Notary Public, Notary Seal  
State of Missouri  
Cass County  
Commission # 20653447  
My Commission Expires 11/18/2024





# Interdepartmental Communication

**DATE:** August 9, 2024

**TO:** Civil Rights and Equal Opportunity

**FROM:** Angela Bennett, Contract Administration

**SUBJECT:** Contract /Project No. 9829-1 /80002486 – Emergency Water Distribution System Repairs Renewal No. 1

Year Two (1<sup>st</sup> renewal of two successive renewal options) for the subject contract according to Ordinance No. 230959. Infrastructure Solutions, LLC We recommend a 1<sup>st</sup> renewal year. The contractor has not requested a Modification Substitution to add a new subcontractor. We recommend the City move forward to renew this contract with Infrastructure Solutions, LLC. **Year Two** with a contract amount of \$2,700,000.00.

- This is a prevailing wage contract.
- Bonds are required. (performance and maintenance bond & payment bond)
- The goals are set at 11% MBE and 11% WBE.
- The Current Annual Amount for this is \$2,700,000.00

The contract renewal information is available upon request.

Approved: DocuSigned by:  
*Mark Runge* 10/1/2024  

---

6AFEC964B03641A  
**(CREO Dept. - Director)**

cc: Jason Wright, Project Manager

The prime contractor indicated that they do plan to meet the MBE goal on the current contract. Currently achieving participation of 6% MBE and 15% WBE. MR



## Inter-Departmental Communication

Date: October 1, 2024

To: Councilman Kevin O'Neill; Chair; Transportation, Infrastructure & Operations Committee

From Jaime Guillen; Director; Civil Rights & Equal Opportunity Department

Subject: CUP Summary #:

---

**CONTRACTOR:** Infrastructure Solutions, LLC  
Address: 9801 Renner Blvd.  
Lenexa, KS 66219  
Contract #: 9829-1 / 80002486- Emergency Water  
Distribution System Repairs- Renewal 1  
Contract Amount: \$2,700,000.00  
MBE Goal: 11%  
WBE Goal: 11%  
Total MBE Achieved: 11%  
Total WBE Achieved: 11%

### **MBE SUBCONTRACTORS:**

Name: Tenoch Construction, Inc.  
Address: 912 Scott Ave.  
Kansas City, KS 66105  
Scope of Work: Concrete / Curbs / Sidewalks  
Subcontract Percentage: 1.5%  
Ownership: Segura-Ulrich, Sonya  
Structure: Hispanic-American Female Code: 19

### **MBE SUBCONTRACTORS:**

Name: Boswell & Lee Trucking, Inc.  
Address: 414 N. 80<sup>th</sup> Terrace  
Kansas City, KS 66112  
Scope of Work: Hauling  
Subcontract Percentage: 9.5%  
Ownership: Boswell, Clarence  
Structure: African-American Male Code: 19

---

**WBE SUBCONTRACTORS:**

Name: Petro Trucking Co., Inc.  
Address: 6028 Cleveland Ave.  
Kansas City, KS 66104  
Scope of Work: Hauling  
Subcontract Percentage: 7%  
Ownership: Pulley, Emma  
Structure: African-American Female Code: 23

**WBE SUBCONTRACTORS:**

Name: Rising Construction Services, Inc.  
Address: 1206 NW Baytree Dr.  
Grain Valley, MO 64029  
Scope of Work: Traffic Control  
Subcontract Percentage: 4%  
Ownership: Rising, Kristen  
Structure: Caucasian Female Code: 27

**Comments:**

According to B2G the prime contractor is currently achieving the following participation on the original contract:

Dollars paid to prime contractor by City to date: \$1,180,109

Dollars paid to MBEs by prime contractor to date: \$67,206.50 for 6% MBE.

Dollars paid to WBEs by prime contractor to date: \$176,189.95 for 15% WBE.

The prime contractor indicated that they are aware that they are currently short of the MBE goal and they plan to make up the shortage over the remaining work on the original contract.

---





# REQUEST FOR MODIFICATION OR SUBSTITUTION

(This Form **must** be submitted to CREO KC to request substitutions for an MBE/WBE listed in the Contractor Utilization Plan or for modification of the amount of MBE/WBE participation listed in the Contractor Utilization Plan. This Form shall be an amendment to the Contractor Utilization Plan.)

**BIDDER/PROPOSER/CONTRACTOR:** \_\_\_\_\_

**ADDRESS:** \_\_\_\_\_

**PROJECT NUMBER OR TITLE:** \_\_\_\_\_

**AMENDMENT/CHANGE ORDER NO: (if applicable)** \_\_\_\_\_

<b>Project Goals:</b>	_____ % MBE	_____ % WBE
<b>Contractor Utilization Plan:</b>	_____ % MBE	_____ % WBE

1. I am the duly authorized representative of the above Bidder/Contractor/Proposer and am authorized to request this substitution or modification on behalf of the Bidder/Contractor/Proposer.

2. I hereby request that the Director of CREO KC recommend or approve: (check appropriate space(s))

a. \_\_\_\_\_ A substitution of the certified MBE/WBE firm \_\_\_\_\_,  
*(Name of new firm)*  
 to perform \_\_\_\_\_,  
*(Scope of work to be performed by new firm)*

for the MBE/WBE firm \_\_\_\_\_ which is currently  
*(Name of old firm)*  
 listed on the Bidder's/Contractor's/Proposer's Contractor Utilization Plan to  
 perform the following scope of work: \_\_\_\_\_.  
*(Scope of work of old firm)*

b. \_\_\_\_\_ A modification of the amount of MBE/WBE participation currently listed on the Bidder's/Contractor's/Proposer's Contractor Utilization Plan from  
 \_\_\_\_\_ % MBE \_\_\_\_\_ % WBE *(Fill in % of MBE/WBE Participation currently listed on Contractor Utilization Plan)*

### TO

\_\_\_\_\_ % MBE \_\_\_\_\_ % WBE *(Fill in New % of MBE/WBE Participation requested for Contractor Utilization Plan)*

- c. Attach 00450.01 Letter of Intent to Subcontract letter for each new MBE/WBE to be added.
- d. Attach a copy of the most recent 00485.01 or on-line M/WBE Monthly Utilization Report

3. Bidder/Contractor/Proposer states that a substitution or modification is necessary because: (check applicable reason(s) )



\_\_\_The MBE/WBE listed on the Contractor Utilization Plan is non-responsive or cannot perform.

\_\_\_The MBE/WBE listed on the Contractor Utilization Plan has increased its previously quoted price without a corresponding change in the scope of work.

\_\_\_The MBE/WBE listed on the Contractor Utilization Plan has committed a material default or breach of its contract.

\_\_\_Requirements of the scope of work of the contract have changed and make subcontracting not feasible or not feasible at the levels required by the goals established for the contract.

\_\_\_The MBE/WBE listed on the Contractor Utilization Plan is unacceptable to the City contracting department.

\_\_\_Bidder/Contractor/Proposer has not attempted intentionally to evade the requirements of the Act and it is in the best interests of the City to allow a modification or substitution.

4. The following is a narrative summary of the Bidder's/Contractor's/Proposer's good faith efforts exhausted in attempts to substitute the MBE/WBE firm named above which is currently listed on the Contractor Utilization Plan with other qualified, certified MBE/WBE firms for the listed scope of work or any other scope of work in the project:

5. Bidder/Proposer/Contractor will present documentation when requested by the City to evidence its good faith efforts.

Dated: \_\_\_\_\_

\_\_\_\_\_  
(Bidder/Proposer/Contractor)

By: \_\_\_\_\_  
(Authorized Representative)



# CREO KC MONTHLY REPORTING INSTRUCTIONS

## M/WBE Monthly Utilization Report Instructions

1. MBE/WBE Reporting applies to Contracts that have approved MBE/WBE goals assigned.
2. The City will utilize a web-based MBE/WBE Reporting System in the administration of this Contract. This web-based application database is a collaboration tool selected and provided by the City, which will allow Contractors and Consultants/Subcontractors and Subconsultants to enter data and report on compliance.

## Prevailing Wage Certified Payroll Report Instructions

1. Prevailing Wage Certified Payroll Report applies to Contracts that include Prevailing Wage or Davis Bacon Provisions.
2. This web-based application database is provided by the City for reporting certified payrolls and other related prevailing wage data.
3. Computer Requirements: Minimum Intel Pentium® 4 Processor 2.4 GHz or equivalent processor with 512MB of RAM; recommended Centrino Duo® Processors 1.6 GHz or equivalent with 2GB of RAM, or higher.
  - a. Computer Operation System: Windows XP, Windows Vista, or Windows 7
  - b. Web Browser: Google Chrome
  - c. Connection Speed/Minimum Bandwidth: DSL, ADSL or T1 Line for transferring a minimum of 3 Mbps Downstream and 512 Kbps Upstream
4. City will assist Contractor in providing training of personnel and Subcontractor's personnel.
5. Contractor and Subcontractors shall have the responsibility for visiting the web site and entering data in on timely basis, and as necessary to be in compliance with Prevailing Wage Requirements included in their contracts.

## Workforce Monthly Report Instructions

1. Workforce Monthly Reporting only applies to Construction Contracts greater than \$300,000 and greater than 800 projected labor hours.
2. The City will utilize a web-based Reporting System in the administration of this Contract. This web-based application database is a collaboration tool selected and provided by the City, which will allow Contractors and Subcontractors to enter data and report on Workforce compliance.



**CITY OF KANSAS CITY, MISSOURI  
Human Relations Department  
M/WBE MONTHLY UTILIZATION REPORT**

<b>Report Date:</b>		<b>Project Name:</b>			<b>City Project Number:</b>				
<b>Project Address:</b>				<b>Contract Award Date:</b>		<b>City Vendor ID:</b>			
<b>General Contractor (GC):</b>				<b>City Contract Number:</b>		<b>City Department Name</b>			
<b>Contact Person/Phone:</b>				<b>General Contract Amount:</b>		<b>Total Amount Paid By City To Date:</b>			
				\$		\$			
<b>General Contractor Address:</b>				<b>Contract Goals:</b> ____% DBE          ____% MBE          ____% WBE					
<b>Email Address:</b>				<b>Total Contract Days:</b>			<b>Completion Date:</b>		
<b>MBE/DBE Subcontractor</b>	<b>Date of Certification</b>	<b>Date of Subcontract</b>	<b>Subcontract Amount</b>	<b>% of Total Contract</b>	<b>Estimated Start date</b>	<b>Amount Paid This Period</b>	<b>Amount Paid To Date</b>	<b>% of Contract Paid to Date</b>	
<b>WBE/DBE Subcontractor</b>									
<b>Totals</b>									

**Contractor should submit report by the 15th of each month.**  
Phillip Yelder, Director  
Human Relations Department  
414 E. 12th Street, 4th Floor  
Kansas City, MO 64106  
Phone: 816-513-1836  
FAX: 816-513-1805

**Narrative:** \_\_\_\_\_  
\_\_\_\_\_  
\_\_\_\_\_  
\_\_\_\_\_  
\_\_\_\_\_  
\_\_\_\_\_  
\_\_\_\_\_  
\_\_\_\_\_

**Report Submitted By:** \_\_\_\_\_ **Date** \_\_\_\_\_

**REMINDER:** CONTRACTOR is responsible for meeting or exceeding the the D/M/WBE participation amounts in its Contractor Utilization Plan (CUP) as amended by any previously approved Request for Modification/Substitution. Any Change Orders or amendments modifying the amount CONTRACTOR is to be compensated will have correspondingly impacted the amount of compensation due D/M/WBEs for purposes of meeting or exceeding the Bidder/Proposer participation. CONTRACTOR is again advised to consider the effect of any Change Order or amendment, and to submit a Request for Modification/Substitution if appropriate.

# M/WBE Monthly Compliance Audit Online Reporting Instructions

## PRIME INSTRUCTIONS:

The Prime's responsibility is to report payments made to subcontractors for the prior month.

1. Log into B2GNow Diversity Management System (B2GNow)
2. On the Dashboard, click Contract Audits.
3. Select the specific audit that needs to be completed. Any and all money that changed hands during the month of the audit must be reported to the specific audit month.
4. To complete audit select Report 1 Subcontractor Payment. Under the actions column, select Submit Response for the specific subcontractor that needs reporting or select the Submit ALL Incomplete Records button to go to all the subcontractors to report amounts. Under the audit information answer the following questions:

Once information has been entered, select review and save. Complete same steps for all subcontractors. If there were subcontractors that did not receive a payment for the specific audit month, click the Mark Remaining Subcontractors as Zero button to mark remaining subcontractors as 0.

## SUBCONTRACTOR INSTRUCTIONS:

The responsibility of the Subcontractor is to confirm payment received for specific audit month.

1. Log in to B2GNow Diversity Management System (B2GNow)
2. On the Dashboard, select Contract Audits.
3. Select the specific audit that needs to be completed.
4. To complete audit, select Confirm Payment Received. There will be two options: correct or incorrect. Select correct if payment was in fact received OR if payment was not received or amount was different select incorrect. Answer all questions and select save to complete.

NOTE: Complete one M/WBE report per project.

An email notice will be sent from our organization monthly to notify Prime & Subcontractor users of incomplete audits.





# Project-Specific Workforce Monthly Report

Human Relations Department - City of Kansas City Missouri

Report Date:	Reporting Period:	Project Description:	
Project Name:	Contractor:	Contract Awarded Date:	
City Project Number:	Contractor Address:	City Contract Number:	
Project Address:		City Vendor ID:	
	Contact Person/Phone:	Contractor Report <input type="checkbox"/>	Subcontractor Report <input type="checkbox"/>
E-mail Address:		Final Cumulative Report:	<input type="checkbox"/> Yes <input type="checkbox"/> No

Report the total monthly hours of work performed by all workers on the City Construction Contract. Enter the total hours on all lines and in all columns. Reported workforce hours should be based on payroll records.

JOB CATEGORIES	OVERALL TOTAL (Sum of all Columns, A thru F Male & Female)	A Total Hours White Employees		B Total Hours Black Employees		C Total Hours Hispanic Employees		D Total Hours Asian/Pacific Islander		E Total Hours Native American Employee		F Total Hours Other/Unknown Race Employee		G KCMO Resident Hours
		M	F	M	F	M	F	M	F	M	F	M	F	Total #
		Foreman/Supervisor												
Asbestos Worker Journeyman														
Asbestos Worker Apprentice														
Boilermaker Journeyman														
Boilermaker Apprentice														
Bricklayer Journeyman														
Bricklayer Apprentice														
Carpenter Journeyman														
Carpenter Apprentice														
Cement Mason Journeyman														
Cement Mason Apprentice														
Electrician Journeyman														
Electrician Apprentice														
Elevator Constructor Journeyman														
Elevator Constructor Apprentice														
Glazier Journeyman														
Glazier Apprentice														
Iron Worker Journeyman														
Iron Worker Apprentice														
Laborer Journeyman														
Laborer Apprentice														
Operating Engineer Journeyman														
Operating Engineer Apprentice														
Painter Journeyman														
Painter Apprentice														
Pipe Fitter/Plumber Journeyman														
Pipe Fitter/Plumber Apprentice														
Plasterer Journeyman														
Plasterer Apprentice														
Roofer Journeyman														
Roofer Apprentice														
Sheet Metal Journeyman														
Sheet Metal Apprentice														
Sprinkler Fitter														
Sprinkler Fitter Apprentice														
Truck Driver Journeyman														
Truck Driver Apprentice														
Welder Journeyman														
Welder Apprentice														
Other														
Monthly Total Hours														-
Total % of Monthly Hrs.														

Contractor shall submit report by the 15th of each month.		Report Submitted By:
Phillip Yelder, Director Human Relations Department		
414 E. 12th Street, 4th Floor	Kansas City, MO 64106	
Phone: 816-513-1836	Email: <a href="mailto:HRDcontractcompliance@kcmo.org">HRDcontractcompliance@kcmo.org</a>	Date:

Workforce Monthly Report Forms only apply to Construction Contracts greater than \$300,000.00 with greater than 800 projected labor hours.

## Workforce Monthly Report Instructions

(Instructions for online reporting)

### Completing a Workforce Audit:

To report your workforce hours:

1. Log into B2GNow Diversity Management System (B2GNow)
2. Click on the red underlined number of 'Incomplete audits' under Workforce Audits
3. Click View for the incomplete audit that needs to be completed.
4. Click Fill in Audit
5. Complete the form including the Payroll Number. Select Add to Audit to report hours worked for specific Craft/Trade.

\* required entry

Summary Information	
CONTRACTOR	KCMO Test Vendor Sample
PAYROLL START DATE	11/1/2021
PAYROLL END DATE	11/30/2021
PAYROLL NUMBER	<input style="width: 100%;" type="text"/>
SPECIAL STATUS	<input type="checkbox"/> No Work (all fields will be filled with zeros) <input type="checkbox"/> Suspended <input type="checkbox"/> Final

Enter values below as hours worked. There is no need to fill in zeros; all blank fields will be saved as zero.

Craft/Trade List															
Craft/Trade	Caucasian		Black/African American		Hispanic/Latino		Asian		Native American		Other/Unknown Ethnicity		Local Resident	Comments	
	Male	Female	Male	Female	Male	Female	Male	Female	Male	Female	Male	Female			
Foreman/Supervisor															Not included in audit <a href="#">Add to Audit</a>
Asbestos Worker (Journeyman)															Not included in audit <a href="#">Add to Audit</a>

6. Scroll down and select review once hours have been reported.
7. Save and Certify to submit OR Save but Certify Later (to save a draft of your audit response). Audit must be certified for the workforce audit to be submitted for review. If there is an audit where no work was performed, and have 0 hours to report, select the Mark as No Work Audit button on step 4 to report 0 hours for all your employees. Select Certify & Release to Organization to complete. Mark Final for Special Status if the audit being completed is the last month of work, this will notify the system to stop generating monthly audits.

**NOTE:** If subcontractor has completed Workforce Audit, Prime MUST either accept audit and release to the organization or reject audit back to Subcontractor for correction.

An email notice will be sent from our organization monthly to notify Prime & Subcontractor users of incomplete audits.



# Company-Wide Workforce Monthly Report

Human Relations Department - City of Kansas City, Missouri

Report Date:	Reporting Period:	Contract Awarded Date:	
Contractor:		City Vendor ID:	
Contact Person/Phone:	Contractor Address:	Contractor Report <input type="checkbox"/>	Subcontractor Report <input type="checkbox"/>
E-mail Address:	Have you hired any new construction workers this month?	<input type="checkbox"/> Yes <input type="checkbox"/> No	Final Cumulative Report: <input type="checkbox"/> Yes <input type="checkbox"/> No

Report total of all hours of work performed company-wide on all projects in the KCMO Metropolitan Statistical Area (MSA). Enter the total hours on all lines and in all columns. Workforce hours should be based on payroll records.

JOB CATEGORIES	OVERALL TOTAL (Sum of all Columns, A thru F Male & Female)	A Total Hours White Employees		B Total Hours Black Employees		C Total Hours Hispanic Employees		D Total Hours Asian/Pacific Islander		E Total Hours Native American Employee		F Total Hours Other/Unknown Race Employee		G KCMO Resident Hours  Total #
		M	F	M	F	M	F	M	F	M	F	M	F	
Foreman/Supervisor														
Asbestos Worker Journeyman														
Asbestos Worker Apprentice														
Boilermaker Journeyman														
Boilermaker Apprentice														
Bricklayer Journeyman														
Bricklayer Apprentice														
Carpenter Journeyman														
Carpenter Apprentice														
Cement Mason Journeyman														
Cement Mason Apprentice														
Electrician Journeyman														
Electrician Apprentice														
Elevator Constructor Journeyman														
Elevator Constructor Apprentice														
Glazier Journeyman														
Glazier Apprentice														
Iron Worker Journeyman														
Iron Worker Apprentice														
Laborer Journeyman														
Laborer Apprentice														
Operating Engineer Journeyman														
Operating Engineer Apprentice														
Painter Journeyman														
Painter Apprentice														
Pipe Fitter/Plumber Journeyman														
Pipe Fitter/Plumber Apprentice														
Plasterer Journeyman														
Plasterer Apprentice														
Roofer Journeyman														
Roofer Apprentice														
Sheet Metal Journeyman														
Sheet Metal Apprentice														
Sprinkler Fitter														
Sprinkler Fitter Apprentice														
Truck Driver Journeyman														
Truck Driver Apprentice														
Welder Journeyman														
Welder Apprentice														
Other														
<b>Total Monthly Hours</b>														
<b>Total % of Hours</b>														

Contractor shall submit report by the 15th of each month.

Phillip Yelder, Director Human Relations Department 414 E. 12th Street, 4th Floor, Kansas City, MO 64106 Phone: 816-513-1836 Email: <a href="mailto:HRDcontractcompliance@kcmo.org">HRDcontractcompliance@kcmo.org</a>	Report Submitted By: _____  Date: _____
--	---

**Civil Rights & Equal Opportunity Department  
Economic Equity & Inclusion  
Contract Closeout Approval Form**

**Date:**  
**Form Prepared By:**

Contract/Project Number:	Project Name:
--------------------------	---------------

Owning Department:	Project Manager:
--------------------	------------------

Funding:       City       State       Federal       CO-OP       Grant:      Other:

Project Requirements:  M/WBE       DBE       SLBE       Section 3       N/A

Tax Incentive:       LCRA       TIF       PIEA       N/A       Other:

Prevailing Wage:       Yes       No

Davis-Bacon:       Yes       No

Construction Employment Program:       Yes: Workforce goals are 10% Minority & 2% Women. There are over 800 Workforce hours and project cost is \$300,000 or more.  
 NO: Workforce hours are less than 800 and project cost is less than \$300,000.

Developer/Prime:	Address:
------------------	----------

Contract Type:

Construction       Design-Build       Design Professional       Professional Services

General Service       Concession       Other Goods & Services       Non-Municipal Agency

Co-Operative       Revenue Sharing       Facilities Maintenance/Repair/Renovation

Other:

**This document is submitted with all available facts. Intentionally falsifying this document or omitting pertinent facts is grounds for disciplinary action pursuant to KCMO Human Resources Rules & Policy Manual (eff. August 4, 2014).**

**FOR CIVIL RIGHTS & EQUAL OPPORTUNITY DEPARTMENT (CREO) USE ONLY:**

<b>Economic Equity &amp; Inclusion Goals:</b>		
<input type="checkbox"/> Approved	<input type="checkbox"/> LD's/Penalties Assessed \$	<input type="checkbox"/> Not Applicable
<b>Electronic Record?</b>	<input type="checkbox"/> Yes	<input type="checkbox"/> No

Economic Equity & Inclusion Division Signature: \_\_\_\_\_ Date: \_\_\_\_\_

<b>Prevailing Wage:</b>		
<input type="checkbox"/> Approved	<input type="checkbox"/> LD's/Penalties Assessed \$	<input type="checkbox"/> Not Applicable
<b>Electronic Record?</b>	<input type="checkbox"/> Yes	<input type="checkbox"/> No

Contract & Labor Standards Division Signature: \_\_\_\_\_ Date: \_\_\_\_\_

<b>Workforce Program:</b>		
<input type="checkbox"/> Approved	<input type="checkbox"/> LD's/Penalties Assessed \$	<input type="checkbox"/> Not Applicable
<b>Electronic Record?</b>	<input type="checkbox"/> Yes	<input type="checkbox"/> No
<b>Public Commendation Recommended:</b>	<input type="checkbox"/> Yes	<input type="checkbox"/> No

Contract & Labor Standards Division Signature: \_\_\_\_\_ Date: \_\_\_\_\_

<b>Additional Comments:</b>
-----------------------------



**EMPLOYEE ELIGIBILITY VERIFICATION AFFIDAVIT**

(Required for any contract with the City of Kansas City, Missouri in excess of \$5,000.00)

STATE OF Kansas )  
 ) ss  
COUNTY OF Johnson )

On this 8<sup>th</sup> day of January, 2024, before me appeared Nate Morgan, personally known by me or otherwise proven to be the person whose name is subscribed on this affidavit and who, being duly sworn, stated as follows:

I am of sound mind, capable of making this affidavit, and personally swear or affirm that the statements made herein are truthful to the best of my knowledge. I am the

Project Manager (title) of Infrastructure Solutions, LLC. (business entity) and I am duly authorized, directed or empowered to act with full authority on behalf of the business entity in making this affidavit.

I hereby swear or affirm that the business entity does not knowingly employ any person in connection with the contracted services who does not have the legal right or authorization under federal law to work in the United States as defined in 8 U.S.C. § 1324a(h)(3).

I hereby additionally swear or affirm that the business entity is enrolled in an electronic verification of work program operated by the United States Department of Homeland Security (E-Verify) or an equivalent federal work authorization program operated by the United States Department of Homeland Security to verify information of newly hired employees, under the Immigration Reform and Control Act of 1986, and that the business entity will participate in said program with respect to any person hired by the business entity to perform any work in connection with the contracted services. I have attached hereto documentation sufficient to establish the business entity's enrollment and participation in the required electronic verification of work program.

I am aware and recognize that unless certain contractual requirements are satisfied and affidavits obtained as provided in Section 285.530, RSMo, the business entity may face liability for violations committed by its subcontractors, notwithstanding the fact that the business entity may itself be compliant.

I acknowledge that I am signing this affidavit as the free act and deed of the business entity and that I am not doing so under duress.

  
\_\_\_\_\_  
Affiant's signature

Subscribed and sworn to before me this 8 day of January, 2024.

  
\_\_\_\_\_  
Notary Public

My Commission expires:

February 1, 2027

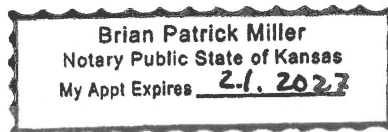

**THE E-VERIFY  
MEMORANDUM OF UNDERSTANDING  
FOR EMPLOYERS**

**ARTICLE I  
PURPOSE AND AUTHORITY**

The parties to this agreement are the Department of Homeland Security (DHS) and the Infrastructure Solutions, Inc. (Employer). The purpose of this agreement is to set forth terms and conditions which the Employer will follow while participating in E-Verify.

E-Verify is a program that electronically confirms an employee's eligibility to work in the United States after completion of Form I-9, Employment Eligibility Verification (Form I-9). This Memorandum of Understanding (MOU) explains certain features of the E-Verify program and describes specific responsibilities of the Employer, the Social Security Administration (SSA), and DHS.

Authority for the E-Verify program is found in Title IV, Subtitle A, of the Illegal Immigration Reform and Immigrant Responsibility Act of 1996 (IIRIRA), Pub. L. 104-208, 110 Stat. 3009, as amended (8 U.S.C. § 1324a note). The Federal Acquisition Regulation (FAR) Subpart 22.18, "Employment Eligibility Verification" and Executive Order 12989, as amended, provide authority for Federal contractors and subcontractors (Federal contractor) to use E-Verify to verify the employment eligibility of certain employees working on Federal contracts.

**ARTICLE II  
RESPONSIBILITIES**

**A. RESPONSIBILITIES OF THE EMPLOYER**

1. The Employer agrees to display the following notices supplied by DHS in a prominent place that is clearly visible to prospective employees and all employees who are to be verified through the system:
  - a. Notice of E-Verify Participation
  - b. Notice of Right to Work
2. The Employer agrees to provide to the SSA and DHS the names, titles, addresses, and telephone numbers of the Employer representatives to be contacted about E-Verify. The Employer also agrees to keep such information current by providing updated information to SSA and DHS whenever the representatives' contact information changes.
3. The Employer agrees to grant E-Verify access only to current employees who need E-Verify access. Employers must promptly terminate an employee's E-Verify access if the employer is separated from the company or no longer needs access to E-Verify.

Company ID Number: 1290795

4. The Employer agrees to become familiar with and comply with the most recent version of the E-Verify User Manual.
  5. The Employer agrees that any Employer Representative who will create E-Verify cases will complete the E-Verify Tutorial before that individual creates any cases.
    - a. The Employer agrees that all Employer representatives will take the refresher tutorials when prompted by E-Verify in order to continue using E-Verify. Failure to complete a refresher tutorial will prevent the Employer Representative from continued use of E-Verify.
  6. The Employer agrees to comply with current Form I-9 procedures, with two exceptions:
    - a. If an employee presents a "List B" identity document, the Employer agrees to only accept "List B" documents that contain a photo. (List B documents identified in 8 C.F.R. § 274a.2(b)(1)(B)) can be presented during the Form I-9 process to establish identity.) If an employee objects to the photo requirement for religious reasons, the Employer should contact E-Verify at 888-464-4218.
    - b. If an employee presents a DHS Form I-551 (Permanent Resident Card), Form I-766 (Employment Authorization Document), or U.S. Passport or Passport Card to complete Form I-9, the Employer agrees to make a photocopy of the document and to retain the photocopy with the employee's Form I-9. The Employer will use the photocopy to verify the photo and to assist DHS with its review of photo mismatches that employees contest. DHS may in the future designate other documents that activate the photo screening tool.
- Note: Subject only to the exceptions noted previously in this paragraph, employees still retain the right to present any List A, or List B and List C, document(s) to complete the Form I-9.
7. The Employer agrees to record the case verification number on the employee's Form I-9 or to print the screen containing the case verification number and attach it to the employee's Form I-9.
  8. The Employer agrees that, although it participates in E-Verify, the Employer has a responsibility to complete, retain, and make available for inspection Forms I-9 that relate to its employees, or from other requirements of applicable regulations or laws, including the obligation to comply with the antidiscrimination requirements of section 274B of the INA with respect to Form I-9 procedures.
    - a. The following modified requirements are the only exceptions to an Employer's obligation to not employ unauthorized workers and comply with the anti-discrimination provision of the INA: (1) List B identity documents must have photos, as described in paragraph 6 above; (2) When an Employer confirms the identity and employment eligibility of newly hired employee using E-Verify procedures, the Employer establishes a rebuttable presumption that it has not violated section 274A(a)(1)(A) of the Immigration and Nationality Act (INA) with respect to the hiring of that employee; (3) If the Employer receives a final nonconfirmation for an employee, but continues to employ that person, the Employer must notify DHS and the Employer is subject to a civil money penalty between \$550 and \$1,100 for each failure to notify DHS of continued employment following a final nonconfirmation; (4) If the Employer continues to employ an employee after receiving a final nonconfirmation, then the Employer is subject to a rebuttable presumption that it has knowingly



**Company ID Number:** 1290795

employed an unauthorized alien in violation of section 274A(a)(1)(A); and (5) no E-Verify participant is civilly or criminally liable under any law for any action taken in good faith based on information provided through the E-Verify.

b. DHS reserves the right to conduct Form I-9 compliance inspections, as well as any other enforcement or compliance activity authorized by law, including site visits, to ensure proper use of E-Verify.

9. The Employer is strictly prohibited from creating an E-Verify case before the employee has been hired, meaning that a firm offer of employment was extended and accepted and Form I-9 was completed. The Employer agrees to create an E-Verify case for new employees within three Employer business days after each employee has been hired (after both Sections 1 and 2 of Form I-9 have been completed), and to complete as many steps of the E-Verify process as are necessary according to the E-Verify User Manual. If E-Verify is temporarily unavailable, the three-day time period will be extended until it is again operational in order to accommodate the Employer's attempting, in good faith, to make inquiries during the period of unavailability.

10. The Employer agrees not to use E-Verify for pre-employment screening of job applicants, in support of any unlawful employment practice, or for any other use that this MOU or the E-Verify User Manual does not authorize.

11. The Employer must use E-Verify for all new employees. The Employer will not verify selectively and will not verify employees hired before the effective date of this MOU. Employers who are Federal contractors may qualify for exceptions to this requirement as described in Article II.B of this MOU.

12. The Employer agrees to follow appropriate procedures (see Article III below) regarding tentative nonconfirmations. The Employer must promptly notify employees in private of the finding and provide them with the notice and letter containing information specific to the employee's E-Verify case. The Employer agrees to provide both the English and the translated notice and letter for employees with limited English proficiency to employees. The Employer agrees to provide written referral instructions to employees and instruct affected employees to bring the English copy of the letter to the SSA. The Employer must allow employees to contest the finding, and not take adverse action against employees if they choose to contest the finding, while their case is still pending. Further, when employees contest a tentative nonconfirmation based upon a photo mismatch, the Employer must take additional steps (see Article III.B. below) to contact DHS with information necessary to resolve the challenge.

13. The Employer agrees not to take any adverse action against an employee based upon the employee's perceived employment eligibility status while SSA or DHS is processing the verification request unless the Employer obtains knowledge (as defined in 8 C.F.R. § 274a.1(l)) that the employee is not work authorized. The Employer understands that an initial inability of the SSA or DHS automated verification system to verify work authorization, a tentative nonconfirmation, a case in continuance (indicating the need for additional time for the government to resolve a case), or the finding of a photo mismatch, does not establish, and should not be interpreted as, evidence that the employee is not work authorized. In any of such cases, the employee must be provided a full and fair opportunity to contest the finding, and if he or she does so, the employee may not be terminated or suffer any adverse employment consequences based upon the employee's perceived employment eligibility status

Company ID Number: 1290795

(including denying, reducing, or extending work hours, delaying or preventing training, requiring an employee to work in poorer conditions, withholding pay, refusing to assign the employee to a Federal contract or other assignment, or otherwise assuming that he or she is unauthorized to work) until and unless secondary verification by SSA or DHS has been completed and a final nonconfirmation has been issued. If the employee does not choose to contest a tentative nonconfirmation or a photo mismatch or if a secondary verification is completed and a final nonconfirmation is issued, then the Employer can find the employee is not work authorized and terminate the employee's employment. Employers or employees with questions about a final nonconfirmation may call E-Verify at 1-888-464-4218 (customer service) or 1-888-897-7781 (worker hotline).

14. The Employer agrees to comply with Title VII of the Civil Rights Act of 1964 and section 274B of the INA as applicable by not discriminating unlawfully against any individual in hiring, firing, employment eligibility verification, or recruitment or referral practices because of his or her national origin or citizenship status, or by committing discriminatory documentary practices. The Employer understands that such illegal practices can include selective verification or use of E-Verify except as provided in part D below, or discharging or refusing to hire employees because they appear or sound "foreign" or have received tentative nonconfirmations. The Employer further understands that any violation of the immigration-related unfair employment practices provisions in section 274B of the INA could subject the Employer to civil penalties, back pay awards, and other sanctions, and violations of Title VII could subject the Employer to back pay awards, compensatory and punitive damages. Violations of either section 274B of the INA or Title VII may also lead to the termination of its participation in E-Verify. If the Employer has any questions relating to the anti-discrimination provision, it should contact OSC at 1-800-255-8155 or 1-800-237-2515 (TDD).

15. The Employer agrees that it will use the information it receives from E-Verify only to confirm the employment eligibility of employees as authorized by this MOU. The Employer agrees that it will safeguard this information, and means of access to it (such as PINS and passwords), to ensure that it is not used for any other purpose and as necessary to protect its confidentiality, including ensuring that it is not disseminated to any person other than employees of the Employer who are authorized to perform the Employer's responsibilities under this MOU, except for such dissemination as may be authorized in advance by SSA or DHS for legitimate purposes.

16. The Employer agrees to notify DHS immediately in the event of a breach of personal information. Breaches are defined as loss of control or unauthorized access to E-Verify personal data. All suspected or confirmed breaches should be reported by calling 1-888-464-4218 or via email at [E-Verify@dhs.gov](mailto:E-Verify@dhs.gov). Please use "Privacy Incident – Password" in the subject line of your email when sending a breach report to E-Verify.

17. The Employer acknowledges that the information it receives from SSA is governed by the Privacy Act (5 U.S.C. § 552a(i)(1) and (3)) and the Social Security Act (42 U.S.C. 1306(a)). Any person who obtains this information under false pretenses or uses it for any purpose other than as provided for in this MOU may be subject to criminal penalties.

18. The Employer agrees to cooperate with DHS and SSA in their compliance monitoring and evaluation of E-Verify, which includes permitting DHS, SSA, their contractors and other agents, upon

Company ID Number: 1290795

reasonable notice, to review Forms I-9 and other employment records and to interview it and its employees regarding the Employer's use of E-Verify, and to respond in a prompt and accurate manner to DHS requests for information relating to their participation in E-Verify.

19. The Employer shall not make any false or unauthorized claims or references about its participation in E-Verify on its website, in advertising materials, or other media. The Employer shall not describe its services as federally-approved, federally-certified, or federally-recognized, or use language with a similar intent on its website or other materials provided to the public. Entering into this MOU does not mean that E-Verify endorses or authorizes your E-Verify services and any claim to that effect is false.

20. The Employer shall not state in its website or other public documents that any language used therein has been provided or approved by DHS, USCIS or the Verification Division, without first obtaining the prior written consent of DHS.

21. The Employer agrees that E-Verify trademarks and logos may be used only under license by DHS/USCIS (see [M-795 \(Web\)](#)) and, other than pursuant to the specific terms of such license, may not be used in any manner that might imply that the Employer's services, products, websites, or publications are sponsored by, endorsed by, licensed by, or affiliated with DHS, USCIS, or E-Verify.

22. The Employer understands that if it uses E-Verify procedures for any purpose other than as authorized by this MOU, the Employer may be subject to appropriate legal action and termination of its participation in E-Verify according to this MOU.

## **B. RESPONSIBILITIES OF FEDERAL CONTRACTORS**

1. If the Employer is a Federal contractor with the FAR E-Verify clause subject to the employment verification terms in Subpart 22.18 of the FAR, it will become familiar with and comply with the most current version of the E-Verify User Manual for Federal Contractors as well as the E-Verify Supplemental Guide for Federal Contractors.

2. In addition to the responsibilities of every employer outlined in this MOU, the Employer understands that if it is a Federal contractor subject to the employment verification terms in Subpart 22.18 of the FAR it must verify the employment eligibility of any "employee assigned to the contract" (as defined in FAR 22.1801). Once an employee has been verified through E-Verify by the Employer, the Employer may not create a second case for the employee through E-Verify.

a. An Employer that is not enrolled in E-Verify as a Federal contractor at the time of a contract award must enroll as a Federal contractor in the E-Verify program within 30 calendar days of contract award and, within 90 days of enrollment, begin to verify employment eligibility of new hires using E-Verify. The Employer must verify those employees who are working in the United States, whether or not they are assigned to the contract. Once the Employer begins verifying new hires, such verification of new hires must be initiated within three business days after the hire date. Once enrolled in E-Verify as a Federal contractor, the Employer must begin verification of employees assigned to the contract within 90 calendar days after the date of enrollment or within 30 days of an employee's assignment to the contract, whichever date is later.

Company ID Number: 1290795

b. Employers enrolled in E-Verify as a Federal contractor for 90 days or more at the time of a contract award must use E-Verify to begin verification of employment eligibility for new hires of the Employer who are working in the United States, whether or not assigned to the contract, within three business days after the date of hire. If the Employer is enrolled in E-Verify as a Federal contractor for 90 calendar days or less at the time of contract award, the Employer must, within 90 days of enrollment, begin to use E-Verify to initiate verification of new hires of the contractor who are working in the United States, whether or not assigned to the contract. Such verification of new hires must be initiated within three business days after the date of hire. An Employer enrolled as a Federal contractor in E-Verify must begin verification of each employee assigned to the contract within 90 calendar days after date of contract award or within 30 days after assignment to the contract, whichever is later.

c. Federal contractors that are institutions of higher education (as defined at 20 U.S.C. 1001(a)), state or local governments, governments of Federally recognized Indian tribes, or sureties performing under a takeover agreement entered into with a Federal agency under a performance bond may choose to only verify new and existing employees assigned to the Federal contract. Such Federal contractors may, however, elect to verify all new hires, and/or all existing employees hired after November 6, 1986. Employers in this category must begin verification of employees assigned to the contract within 90 calendar days after the date of enrollment or within 30 days of an employee's assignment to the contract, whichever date is later.

d. Upon enrollment, Employers who are Federal contractors may elect to verify employment eligibility of all existing employees working in the United States who were hired after November 6, 1986, instead of verifying only those employees assigned to a covered Federal contract. After enrollment, Employers must elect to verify existing staff following DHS procedures and begin E-Verify verification of all existing employees within 180 days after the election.

e. The Employer may use a previously completed Form I-9 as the basis for creating an E-Verify case for an employee assigned to a contract as long as:

- i. That Form I-9 is complete (including the SSN) and complies with Article II.A.6,
- ii. The employee's work authorization has not expired, and
- iii. The Employer has reviewed the Form I-9 information either in person or in communications with the employee to ensure that the employee's Section 1, Form I-9 attestation has not changed (including, but not limited to, a lawful permanent resident alien having become a naturalized U.S. citizen).

f. The Employer shall complete a new Form I-9 consistent with Article II.A.6 or update the previous Form I-9 to provide the necessary information if:

- i. The Employer cannot determine that Form I-9 complies with Article II.A.6,
- ii. The employee's basis for work authorization as attested in Section 1 has expired or changed, or
- iii. The Form I-9 contains no SSN or is otherwise incomplete.

Note: If Section 1 of Form I-9 is otherwise valid and up-to-date and the form otherwise complies with

**Company ID Number:** 1290795

Article II.C.5, but reflects documentation (such as a U.S. passport or Form I-551) that expired after completing Form I-9, the Employer shall not require the production of additional documentation, or use the photo screening tool described in Article II.A.5, subject to any additional or superseding instructions that may be provided on this subject in the E-Verify User Manual.

g. The Employer agrees not to require a second verification using E-Verify of any assigned employee who has previously been verified as a newly hired employee under this MOU or to authorize verification of any existing employee by any Employer that is not a Federal contractor based on this Article.

3. The Employer understands that if it is a Federal contractor, its compliance with this MOU is a performance requirement under the terms of the Federal contract or subcontract, and the Employer consents to the release of information relating to compliance with its verification responsibilities under this MOU to contracting officers or other officials authorized to review the Employer's compliance with Federal contracting requirements.

### **C. RESPONSIBILITIES OF SSA**

1. SSA agrees to allow DHS to compare data provided by the Employer against SSA's database. SSA sends DHS confirmation that the data sent either matches or does not match the information in SSA's database.

2. SSA agrees to safeguard the information the Employer provides through E-Verify procedures. SSA also agrees to limit access to such information, as is appropriate by law, to individuals responsible for the verification of Social Security numbers or responsible for evaluation of E-Verify or such other persons or entities who may be authorized by SSA as governed by the Privacy Act (5 U.S.C. § 552a), the Social Security Act (42 U.S.C. 1306(a)), and SSA regulations (20 CFR Part 401).

3. SSA agrees to provide case results from its database within three Federal Government work days of the initial inquiry. E-Verify provides the information to the Employer.

4. SSA agrees to update SSA records as necessary if the employee who contests the SSA tentative nonconfirmation visits an SSA field office and provides the required evidence. If the employee visits an SSA field office within the eight Federal Government work days from the date of referral to SSA, SSA agrees to update SSA records, if appropriate, within the eight-day period unless SSA determines that more than eight days may be necessary. In such cases, SSA will provide additional instructions to the employee. If the employee does not visit SSA in the time allowed, E-Verify may provide a final nonconfirmation to the employer.

Note: If an Employer experiences technical problems, or has a policy question, the employer should contact E-Verify at 1-888-464-4218.

### **D. RESPONSIBILITIES OF DHS**

1. DHS agrees to provide the Employer with selected data from DHS databases to enable the Employer to conduct, to the extent authorized by this MOU:

a. Automated verification checks on alien employees by electronic means, and

Company ID Number: 1290795

- b. Photo verification checks (when available) on employees.
2. DHS agrees to assist the Employer with operational problems associated with the Employer's participation in E-Verify. DHS agrees to provide the Employer names, titles, addresses, and telephone numbers of DHS representatives to be contacted during the E-Verify process.
3. DHS agrees to provide to the Employer with access to E-Verify training materials as well as an E-Verify User Manual that contain instructions on E-Verify policies, procedures, and requirements for both SSA and DHS, including restrictions on the use of E-Verify.
4. DHS agrees to train Employers on all important changes made to E-Verify through the use of mandatory refresher tutorials and updates to the E-Verify User Manual. Even without changes to E-Verify, DHS reserves the right to require employers to take mandatory refresher tutorials.
5. DHS agrees to provide to the Employer a notice, which indicates the Employer's participation in E-Verify. DHS also agrees to provide to the Employer anti-discrimination notices issued by the Office of Special Counsel for Immigration-Related Unfair Employment Practices (OSC), Civil Rights Division, U.S. Department of Justice.
6. DHS agrees to issue each of the Employer's E-Verify users a unique user identification number and password that permits them to log in to E-Verify.
7. DHS agrees to safeguard the information the Employer provides, and to limit access to such information to individuals responsible for the verification process, for evaluation of E-Verify, or to such other persons or entities as may be authorized by applicable law. Information will be used only to verify the accuracy of Social Security numbers and employment eligibility, to enforce the INA and Federal criminal laws, and to administer Federal contracting requirements.
8. DHS agrees to provide a means of automated verification that provides (in conjunction with SSA verification procedures) confirmation or tentative nonconfirmation of employees' employment eligibility within three Federal Government work days of the initial inquiry.
9. DHS agrees to provide a means of secondary verification (including updating DHS records) for employees who contest DHS tentative nonconfirmations and photo mismatch tentative nonconfirmations. This provides final confirmation or nonconfirmation of the employees' employment eligibility within 10 Federal Government work days of the date of referral to DHS, unless DHS determines that more than 10 days may be necessary. In such cases, DHS will provide additional verification instructions.

### **ARTICLE III**

#### **REFERRAL OF INDIVIDUALS TO SSA AND DHS**

##### **A. REFERRAL TO SSA**

1. If the Employer receives a tentative nonconfirmation issued by SSA, the Employer must print the notice as directed by E-Verify. The Employer must promptly notify employees in private of the finding and provide them with the notice and letter containing information specific to the employee's E-Verify

Company ID Number: 1290795

case. The Employer also agrees to provide both the English and the translated notice and letter for employees with limited English proficiency to employees. The Employer agrees to provide written referral instructions to employees and instruct affected employees to bring the English copy of the letter to the SSA. The Employer must allow employees to contest the finding, and not take adverse action against employees if they choose to contest the finding, while their case is still pending.

2. The Employer agrees to obtain the employee's response about whether he or she will contest the tentative nonconfirmation as soon as possible after the Employer receives the tentative nonconfirmation. Only the employee may determine whether he or she will contest the tentative nonconfirmation.
3. After a tentative nonconfirmation, the Employer will refer employees to SSA field offices only as directed by E-Verify. The Employer must record the case verification number, review the employee information submitted to E-Verify to identify any errors, and find out whether the employee contests the tentative nonconfirmation. The Employer will transmit the Social Security number, or any other corrected employee information that SSA requests, to SSA for verification again if this review indicates a need to do so.
4. The Employer will instruct the employee to visit an SSA office within eight Federal Government work days. SSA will electronically transmit the result of the referral to the Employer within 10 Federal Government work days of the referral unless it determines that more than 10 days is necessary.
5. While waiting for case results, the Employer agrees to check the E-Verify system regularly for case updates.
6. The Employer agrees not to ask the employee to obtain a printout from the Social Security Administration number database (the Numident) or other written verification of the SSN from the SSA.

## **B. REFERRAL TO DHS**

1. If the Employer receives a tentative nonconfirmation issued by DHS, the Employer must promptly notify employees in private of the finding and provide them with the notice and letter containing information specific to the employee's E-Verify case. The Employer also agrees to provide both the English and the translated notice and letter for employees with limited English proficiency to employees. The Employer must allow employees to contest the finding, and not take adverse action against employees if they choose to contest the finding, while their case is still pending.
2. The Employer agrees to obtain the employee's response about whether he or she will contest the tentative nonconfirmation as soon as possible after the Employer receives the tentative nonconfirmation. Only the employee may determine whether he or she will contest the tentative nonconfirmation.
3. The Employer agrees to refer individuals to DHS only when the employee chooses to contest a tentative nonconfirmation.
4. If the employee contests a tentative nonconfirmation issued by DHS, the Employer will instruct the

**Company ID Number:** 1290795

employee to contact DHS through its toll-free hotline (as found on the referral letter) within eight Federal Government work days.

5. If the Employer finds a photo mismatch, the Employer must provide the photo mismatch tentative nonconfirmation notice and follow the instructions outlined in paragraph 1 of this section for tentative nonconfirmations, generally.
6. The Employer agrees that if an employee contests a tentative nonconfirmation based upon a photo mismatch, the Employer will send a copy of the employee's Form I-551, Form I-766, U.S. Passport, or passport card to DHS for review by:
  - a. Scanning and uploading the document, or
  - b. Sending a photocopy of the document by express mail (furnished and paid for by the employer).
7. The Employer understands that if it cannot determine whether there is a photo match/mismatch, the Employer must forward the employee's documentation to DHS as described in the preceding paragraph. The Employer agrees to resolve the case as specified by the DHS representative who will determine the photo match or mismatch.
8. DHS will electronically transmit the result of the referral to the Employer within 10 Federal Government work days of the referral unless it determines that more than 10 days is necessary.
9. While waiting for case results, the Employer agrees to check the E-Verify system regularly for case updates.

## **ARTICLE IV SERVICE PROVISIONS**

### **A. NO SERVICE FEES**

1. SSA and DHS will not charge the Employer for verification services performed under this MOU. The Employer is responsible for providing equipment needed to make inquiries. To access E-Verify, an Employer will need a personal computer with Internet access.

## **ARTICLE V MODIFICATION AND TERMINATION**

### **A. MODIFICATION**

1. This MOU is effective upon the signature of all parties and shall continue in effect for as long as the SSA and DHS operates the E-Verify program unless modified in writing by the mutual consent of all parties.
2. Any and all E-Verify system enhancements by DHS or SSA, including but not limited to E-Verify checking against additional data sources and instituting new verification policies or procedures, will be covered under this MOU and will not cause the need for a supplemental MOU that outlines these changes.



Company ID Number: 1290795

## B. TERMINATION

1. The Employer may terminate this MOU and its participation in E-Verify at any time upon 30 days prior written notice to the other parties.
2. Notwithstanding Article V, part A of this MOU, DHS may terminate this MOU, and thereby the Employer's participation in E-Verify, with or without notice at any time if deemed necessary because of the requirements of law or policy, or upon a determination by SSA or DHS that there has been a breach of system integrity or security by the Employer, or a failure on the part of the Employer to comply with established E-Verify procedures and/or legal requirements. The Employer understands that if it is a Federal contractor, termination of this MOU by any party for any reason may negatively affect the performance of its contractual responsibilities. Similarly, the Employer understands that if it is in a state where E-Verify is mandatory, termination of this by any party MOU may negatively affect the Employer's business.
3. An Employer that is a Federal contractor may terminate this MOU when the Federal contract that requires its participation in E-Verify is terminated or completed. In such cases, the Federal contractor must provide written notice to DHS. If an Employer that is a Federal contractor fails to provide such notice, then that Employer will remain an E-Verify participant, will remain bound by the terms of this MOU that apply to non-Federal contractor participants, and will be required to use the E-Verify procedures to verify the employment eligibility of all newly hired employees.
4. The Employer agrees that E-Verify is not liable for any losses, financial or otherwise, if the Employer is terminated from E-Verify.

## ARTICLE VI PARTIES

- A. Some or all SSA and DHS responsibilities under this MOU may be performed by contractor(s), and SSA and DHS may adjust verification responsibilities between each other as necessary. By separate agreement with DHS, SSA has agreed to perform its responsibilities as described in this MOU.
- B. Nothing in this MOU is intended, or should be construed, to create any right or benefit, substantive or procedural, enforceable at law by any third party against the United States, its agencies, officers, or employees, or against the Employer, its agents, officers, or employees.
- C. The Employer may not assign, directly or indirectly, whether by operation of law, change of control or merger, all or any part of its rights or obligations under this MOU without the prior written consent of DHS, which consent shall not be unreasonably withheld or delayed. Any attempt to sublicense, assign, or transfer any of the rights, duties, or obligations herein is void.
- D. Each party shall be solely responsible for defending any claim or action against it arising out of or related to E-Verify or this MOU, whether civil or criminal, and for any liability wherefrom, including (but not limited to) any dispute between the Employer and any other person or entity regarding the applicability of Section 403(d) of IIRIRA to any action taken or allegedly taken by the Employer.
- E. The Employer understands that its participation in E-Verify is not confidential information and may be disclosed as authorized or required by law and DHS or SSA policy, including but not limited to,

Company ID Number: 1290795

Congressional oversight, E-Verify publicity and media inquiries, determinations of compliance with Federal contractual requirements, and responses to inquiries under the Freedom of Information Act (FOIA).

F. The individuals whose signatures appear below represent that they are authorized to enter into this MOU on behalf of the Employer and DHS respectively. The Employer understands that any inaccurate statement, representation, data or other information provided to DHS may subject the Employer, its subcontractors, its employees, or its representatives to: (1) prosecution for false statements pursuant to 18 U.S.C. 1001 and/or; (2) immediate termination of its MOU and/or; (3) possible debarment or suspension.

G. The foregoing constitutes the full agreement on this subject between DHS and the Employer.

**To be accepted as an E-Verify participant, you should only sign the Employer's Section of the signature page. If you have any questions, contact E-Verify at 1-888-464-4218.**

Company ID Number: 1290795

**Approved by:**

<b>Employer</b> Infrastructure Solutions, Inc.	
Name (Please Type or Print) Wendee Woodson	Title
Signature Electronically Signed	Date 04/17/2018
<b>Department of Homeland Security – Verification Division</b>	
Name (Please Type or Print) USCIS Verification Division	Title
Signature Electronically Signed	Date 04/17/2018

Company ID Number: 1290795

**Information Required for the E-Verify Program****Information relating to your Company:**

Company Name	Infrastructure Solutions, Inc.
Company Facility Address	9801 Renner Blvd. Suite 300 Lenexa, KS 66219
Company Alternate Address	
County or Parish	JOHNSON
Employer Identification Number	824483660
North American Industry Classification Systems Code	237
Parent Company	GBA, Inc.
Number of Employees	1 to 4
Number of Sites Verified for	1



Company ID Number: 1290795

**Are you verifying for more than 1 site? If yes, please provide the number of sites verified for in each State:**

KANSAS	1 site(s)
--------	-----------

Company ID Number: 1290795

**Information relating to the Program Administrator(s) for your Company on policy questions or operational problems:**

Name Laurie Cybulski  
Phone Number (913) 577 - 8358  
Fax Number (913) 577 - 8306  
Email Address lcybulski@gbateam.com

Name Wendee Woodson  
Phone Number (913) 577 - 8230  
Fax Number (913) 577 - 8306  
Email Address wwoodson@gbateam.com

Company ID Number: 1290795

Page intentionally left blank



Missouri Department of Revenue  
**Project Exemption Certificate**

This form is to be completed and given to your contractor.

<b>Exempt Entity and Project Information</b>	Name of Exempt Entity Issuing the Certificate		Missouri Tax Exemption Number			
	Address		City		State	ZIP Code
	E-mail Address					
	Project Number	Project Begin Date (MM/DD/YYYY) ____/____/____		Estimated Project End Date (MM/DD/YYYY) ____/____/____		
	Description of Project					
	Project Location			Certificate Expiration Date (MM/DD/YYYY) ____/____/____		
	Provide a signed copy of this certificate, along with a copy of the exempt entity's Missouri Sales and Use Tax Exemption Letter to each contractor or subcontractor who will be purchasing tangible personal property for use in this project. It is the responsibility of the exempt entity to ensure the validity of the information on the certificate. The exempt entity must issue a new certificate if any of the information changes.					
Signature of Authorized Exempt Entity		Printed Name of Authorized Exempt Entity		Date (MM/DD/YYYY) ____/____/____		

<b>Contractor</b>	The Missouri exempt entity named above hereby authorizes the purchase, without sales tax, of tangible personal property to be incorporated or consumed in the construction project identified herein and no other, pursuant to <a href="#">Section 144.062, RSMo</a> . Under penalties of perjury, I declare that the above information and any attached supplement is true, complete, and correct.					
	Name of Purchasing Contractor		Signature of Contractor		Date (MM/DD/YYYY) ____/____/____	
	Address		City		State	ZIP Code

<b>Subcontractor</b>	Contractors - Present this to your supplier in order to purchase the necessary materials tax exempt. Complete the Subcontractor portion if extending the certificate to your subcontractor. The contractor must sign the form in the space provided below.					
	Name of Purchasing Subcontractor					
	Address		City		State	ZIP Code
	Signature of Contractor		Contractor's Printed Name		Date (MM/DD/YYYY) ____/____/____	

Form 5060 (Revised 08-2015)

Taxation Division  
P.O Box 358  
Jefferson City, MO 65105-0358

**Phone:** (573) 751-2836  
**Fax:** (573) 522-1271  
**E-mail:** [salestaxexemptions@dor.mo.gov](mailto:salestaxexemptions@dor.mo.gov)

Visit <http://dor.mo.gov/business/sales/sales-use-exemptions.php> for additional information.





# State of Missouri

## EXEMPTION FROM MISSOURI SALES AND USE TAX ON PURCHASES

Issued to:

CITY OF KANSAS CITY  
414 E 12TH ST 3RD FLOOR  
KANSAS CITY MO 64106

Missouri Tax ID  
Number: 12490466

Effective Date:  
07/11/2002

Your application for sales/use tax exempt status has been approved pursuant to Section 144.030.1, RSMo. This letter is issued as documentation of your exempt status.

Purchases by your Agency are not subject to sales or use tax if within the conduct of your Agency's exempt functions and activities. When purchasing with this exemption, furnish all sellers or vendors a copy of this letter. This exemption may not be used by individuals making personal purchases.

A contractor may purchase and pay for construction materials exempt from sales tax when fulfilling a contract with your Agency only if your Agency issues a project exemption certificate and the contractor makes purchases in compliance with the provisions of Section 144.062, RSMo.

Sales by your Agency are subject to all applicable state and local sales taxes. If you engage in the business of selling tangible personal property or taxable services at retail, you must obtain a Missouri Retail Sales Tax License and collect and remit sales tax.

This is a continuing exemption subject to legislative changes and review by the Director of Revenue. If your Agency ceases to qualify as an exempt entity, this exemption will cease to be valid. This exemption is not assignable or transferable. It is an exemption from sales and use taxes only and is not an exemption from real or personal property tax.

Any alteration to this exemption letter renders it invalid.

If you have any questions regarding the use of this letter, please contact the Division of Taxation and Collection, P.O. Box 3300, Jefferson City, MO 65105-3300, phone 573-751-2836.

[MY ACCOUNT](#)[HOME](#)[SEARCH](#)[MISC INFO](#)[UCC FILING](#)[Help](#)

### Limited Liability Company Details as of 1/8/2024

Required Field \*

**File Documents** - select the filing from the "Filing Type" drop-down list, then click FILE ONLINE.

**File Registration Reports** - click FILE REGISTRATION REPORT.

**Copies or Certificates** - click FILE COPIES/CERTIFICATES.

[RETURN TO SEARCH RESULTS](#)

Create Filing

Amended Certificate of Registration of a Foreign LLC

[FILE ONLINE](#)[ORDER COPIES/ CERTIFICATES](#)[General Information](#)[Filings](#)[Principal Office Address](#)[Contact\(s\)](#)

Name **INFRASTRUCTURE SOLUTIONS, LLC**

Principal Office Address

Type **Limited Liability Company**

Charter No. **FL001423310**

Domesticity **Foreign**

Home State **KS**

Registered Agent **REGISTERED AGENTS INC**  
**117 South Lexington Street**  
**Ste 100**  
**Harrisonville, MO 64701**

Status **Active**

Date Formed **3/13/2018**

Duration **Perpetual**

The information contained on this page is provided as a public service, and may change at any time. The State, its employees, contractors, subcontractors or their employees do not make any warranty, expressed or implied, or assume any legal liability for the accuracy, completeness or usefulness of any information, apparatus, product or process disclosed or represent that its use would not infringe on privately-owned rights.

Hey there! I am an A.I. chatbot, let's talk.



# PERFORMANCE AND MAINTENANCE BOND

Project/Contract Numbers: 80002486/9829-1

Project Title: Emergency Water Distribution System Repairs  
Renewal No. 1

KNOW ALL MEN BY THESE PRESENTS: That Infrastructure Solutions, LLC., as PRINCIPAL (CONTRACTOR), and \_\_\_\_\_, (SURETY), licensed to do business as such in the State of Missouri, hereby bind themselves and their respective heirs, executors, administrators, successors, and assigns unto Kansas City, Missouri, a constitutionally chartered municipal corporation, (OWNER), as obligee, in the penal sum of \_\_\_\_\_ Dollars (\$ \_\_\_\_\_) for the payment whereof CONTRACTOR and SURETY bind themselves, their heirs, executors, administrators, successors and assigns, jointly and severally, firmly by these presents.

WHEREAS,

CONTRACTOR has entered into a Contract with OWNER for **Project/Contract Nos. 80002486/9829-1, Emergency Water Distribution System Repairs Renewal No. 1**, which Contract, including any present or future amendment thereto, is incorporated herein by reference and is hereinafter referred to as the Contract.

NOW, THEREFORE, THE CONDITION OF THIS OBLIGATION is such that, if CONTRACTOR shall promptly and faithfully perform said Contract including all duly authorized changes thereto, and including any maintenance requirements contained therein, according to all the terms thereof, including those under which CONTRACTOR agrees to pay legally required wage rates including the prevailing hourly rate of wages in the locality, as determined by the Department of Labor and Industrial Relations or by final judicial determination, for each craft or type of workman required to execute the Contract and, further, shall defend, indemnify, and hold harmless OWNER from all damages, including but not limited to, liquidated damages, loss and expense occasioned by any failure whatsoever of said CONTRACTOR and SURETY to fully comply with and carry out each and every requirement of the Contract, then this obligation shall be void; otherwise, it shall remain in full force and effect.

WAIVER. That SURETY, for value received, hereby expressly agrees that no change, extension of time, alteration or addition to the terms of the Contract or to the Work to be performed thereunder, shall in any way affect the obligations of this Bond; and it does hereby waive notice of any such change, extension of time, or alteration or addition to the terms of the Contract or the Work to be performed thereunder.

IN WITNESS WHEREOF, the above parties have executed this instrument the \_\_\_\_ day of \_\_\_\_\_, 20\_\_.

**CONTRACTOR**

Name, address and facsimile number of Contractor

\_\_\_\_\_  
\_\_\_\_\_  
\_\_\_\_\_  
\_\_\_\_\_

I hereby certify that I have authority to execute this document on behalf of Contractor.

By: \_\_\_\_\_  
Title: \_\_\_\_\_

(Attach corporate seal if applicable)

**SURETY**

Name, address and facsimile number of Surety:

---

---

---

---

I hereby certify that (1) I have authority to execute this document on behalf of Surety; (2) Surety has an A.M. Best rating of A-, V, or better; (3) Surety is named in the current list of "Companies Holding Certificates of Authority as Acceptable Reinsuring Companies: as published in Circular 570 (most current revision) by the Financial Management Service, Surety Bond Branch, U.S. Department of the Treasury; and (4) Surety is duly licensed to issue bonds in the State of Missouri and in the jurisdiction in which the Project is located.

By: \_\_\_\_\_

Title: \_\_\_\_\_

Date: \_\_\_\_\_

(Attach seal and Power of Attorney)



## PAYMENT BOND

Project/Contract Numbers: 80002486/9829-1

Project Title: Emergency Water Distribution System Repairs  
Renewal No.1

---

KNOW ALL MEN BY THESE PRESENTS: That Infrastructure Solutions, LLC., as PRINCIPAL (CONTRACTOR), and \_\_\_\_\_, (SURETY), licensed to do business as such in the State of Missouri, hereby bind themselves and their respective heirs, executors, administrators, successors, and assigns unto Kansas City, Missouri, a constitutionally chartered municipal corporation, (OWNER), as obligee, in the penal sum of \_\_\_\_\_ Dollars (\$\_\_\_\_\_) for the payment whereof CONTRACTOR and SURETY bind themselves, their heirs, executors, administrators, successors and assigns, jointly and severally, firmly by these presents.

WHEREAS,

CONTRACTOR has entered into a contract with OWNER for **Project/Contract Nos. 80002486/9829-1, Emergency Water Distribution System Repairs Renewal No. 1** which Contract, including any present or future amendment thereto, is incorporated herein by reference and is hereinafter referred to as the Contract.

NOW, THEREFORE, THE CONDITION OF THIS OBLIGATION is such that, if in connection with the Contract, including all duly authorized modifications thereto, prompt payment shall be made to all laborers, subcontractors, teamsters, truck drivers, owners or other suppliers or for equipment employed on the job, and other claimants, for all labor performed in such work whether done for CONTRACTOR, a subcontractor, SURETY, a completion contractor or otherwise (at the full wage rates required by any law of the United States or of the State of Missouri, where applicable), for services furnished and consumed, for repairs on machinery, for equipment, tools, materials, lubricants, oil, gasoline, water, gas, power, light, heat, oil, telephone service, grain, hay, feed, coal, coke, groceries and foodstuffs, either consumed, rented, used or reasonably required for use in connection with the construction of the work or in the performance of the Contract and all insurance premiums, both for compensation and for all other kinds of insurance on the work, for sales taxes and for royalties in connection with, or incidental to, the completion of the Contract, in all instances whether the claim be directly against CONTRACTOR, against SURETY or its completion contractor, through a subcontractor or otherwise, and, further, if CONTRACTOR shall defend, indemnify and hold harmless OWNER from all such claims, demands or suits by any such person or entity, then this obligation shall be void; otherwise, it shall remain in full force and effect.

Any conditions legally required to be included in a Payment Bond on this Contract, including but not limited to those set out in §107.170 RSMo. are included herein by reference.

SURETY agrees that, in the event that CONTRACTOR fails to make payment of the obligations covered by this Bond, it will do so and, further, that within forty-five (45) days of receiving, at the address given below, a claim hereunder stating the amount claimed and the basis for the claim in reasonable detail, it (a) will send an answer to the claimant, with a copy to OWNER stating the amounts that are undisputed and the basis for challenging any amounts that are disputed, and (b) will pay any amounts that are undisputed. The amount of this Bond shall be reduced by and to the extent of any payment or payments made in good faith hereunder.

While this Bond is in force, it may be sued on at the instance of any party to whom any such payment is due, in the name of OWNER to the use for such party. OWNER shall not be liable for the payment of any costs or expenses of any such suit.

No suit shall be commenced or pursued hereunder other than in a state court of competent jurisdiction in Jackson, Clay or Platte County, Missouri, or in the United States District Court for the Western District of

Missouri.

WAIVER. That SURETY, for value received, hereby expressly agrees that no change, extension of time, alteration or addition to the terms of the Contract or to the Work to be performed thereunder, shall in any way affect the obligations of this Bond; and it does hereby waive notice of any such change, extension of time, or alteration or addition to the terms of the Contract or the Work to be performed thereunder.

IN WITNESS WHEREOF, the above parties have executed this instrument the \_\_\_\_\_ day of \_\_\_\_\_, 20\_\_\_\_\_.

**CONTRACTOR**

Name, address and facsimile number of Contractor

\_\_\_\_\_  
\_\_\_\_\_  
\_\_\_\_\_

I hereby certify that I have authority to execute this document on behalf of Contractor.

By: \_\_\_\_\_  
Title: \_\_\_\_\_

(Attach corporate seal if applicable)

**SURETY**

Name, address and facsimile number of Surety:

\_\_\_\_\_  
\_\_\_\_\_  
\_\_\_\_\_

I hereby certify that (1) I have authority to execute this document on behalf of Surety; (2) Surety has an A.M. Best rating of A-. or better; (3) Surety is named in the current list of "Companies Holding Certificates of Authority as Acceptable Sureties on Federal Bonds and as Acceptable Reinsuring Companies" as published in Circular 570 (most current revision) by the Financial Management Service, Surety Bond Branch, U.S. Department of the Treasury; and(4) Surety is duly licensed to issue bonds in the State of Missouri and in the jurisdiction in which the Project is located.

By: \_\_\_\_\_  
Title: \_\_\_\_\_  
Date: \_\_\_\_\_

(Attach seal and Power of Attorney)



# CERTIFICATE OF LIABILITY INSURANCE

DATE (MM/DD/YYYY)

THIS CERTIFICATE IS ISSUED AS A MATTER OF INFORMATION ONLY AND CONFERS NO RIGHTS UPON THE CERTIFICATE HOLDER. THIS CERTIFICATE DOES NOT AFFIRMATIVELY OR NEGATIVELY AMEND, EXTEND OR ALTER THE COVERAGE AFFORDED BY THE POLICIES BELOW. THIS CERTIFICATE OF INSURANCE DOES NOT CONSTITUTE A CONTRACT BETWEEN THE ISSUING INSURER(S), AUTHORIZED REPRESENTATIVE OR PRODUCER, AND THE CERTIFICATE HOLDER.

**IMPORTANT:** If the certificate holder is an ADDITIONAL INSURED, the policy(ies) must be endorsed. If SUBROGATION IS WAIVED, subject to the terms and conditions of the policy, certain policies may require an endorsement. A statement on this certificate does not confer rights to the certificate holder in lieu of such endorsement(s).

PRODUCER AGENT NAME AND ADDRESS	CONTACT NAME:	
	PHONE (A/C, No, Ext):	FAX (A/C, No):
INSURED CONTRACTOR NAME AND ADDRESS	E-MAIL ADDRESS:	
	INSURER(S) AFFORDING COVERAGE	
	INSURER A :	ABC INSURANCE COMPANY
	INSURER B :	
	INSURER C :	
	INSURER D :	
	INSURER E :	
	INSURER F :	

**COVERAGES****CERTIFICATE NUMBER:****REVISION NUMBER:**

THIS IS TO CERTIFY THAT THE POLICIES OF INSURANCE LISTED BELOW HAVE BEEN ISSUED TO THE INSURED NAMED ABOVE FOR THE POLICY PERIOD INDICATED. NOTWITHSTANDING ANY REQUIREMENT, TERM OR CONDITION OF ANY CONTRACT OR OTHER DOCUMENT WITH RESPECT TO WHICH THIS CERTIFICATE MAY BE ISSUED OR MAY PERTAIN, THE INSURANCE AFFORDED BY THE POLICIES DESCRIBED HEREIN IS SUBJECT TO ALL THE TERMS, EXCLUSIONS AND CONDITIONS OF SUCH POLICIES. LIMITS SHOWN MAY HAVE BEEN REDUCED BY PAID CLAIMS.

INSR LTR	TYPE OF INSURANCE	ADDL INSR	SUBR WVD	POLICY NUMBER	POLICY EFF (MM/DD/YYYY)	POLICY EXP (MM/DD/YYYY)	LIMITS	
A	<b>GENERAL LIABILITY</b> <input checked="" type="checkbox"/> COMMERCIAL GENERAL LIABILITY <input type="checkbox"/> CLAIMS-MADE <input checked="" type="checkbox"/> OCCUR GEN'L AGGREGATE LIMIT APPLIES PER: <input type="checkbox"/> POLICY <input checked="" type="checkbox"/> PROJECT <input type="checkbox"/> LOC	Y	Y	POLICY NUMBER	1/1/2011	Current	EACH OCCURRENCE \$ 1,000,000 DAMAGE TO RENTED PREMISES (Ea occurrence) \$ 50,000 MED EXP (Any one person) \$ 10,000 PERSONAL & ADV INJURY \$ 1,000,000 GENERAL AGGREGATE \$ 2,000,000 PRODUCTS - COMP/OP AGG \$ 2,000,000 \$	
A	<b>AUTOMOBILE LIABILITY</b> <input checked="" type="checkbox"/> ANY AUTO ALL OWNED AUTOS <input checked="" type="checkbox"/> HIRED AUTOS <input type="checkbox"/> SCHEDULED AUTOS NON-OWNED AUTOS	Y	Y	POLICY NUMBER	1/1/2011	Current	COMBINED SINGLE LIMIT (Ea accident) \$ 1,000,000 BODILY INJURY (Per person) \$ BODILY INJURY (Per accident) \$ PROPERTY DAMAGE (Per accident) \$ \$	
A	<input checked="" type="checkbox"/> UMBRELLA LIAB <input checked="" type="checkbox"/> EXCESS LIAB <input checked="" type="checkbox"/> OCCUR CLAIMS-MADE DED <input checked="" type="checkbox"/> RETENTION \$ 10,000	Y	Y	POLICY NUMBER	1/1/2011	Current	EACH OCCURRENCE \$ 2,000,000 AGGREGATE \$ 2,000,000 \$	
A	<b>WORKERS COMPENSATION AND EMPLOYERS' LIABILITY</b> ANY PROPRIETOR/PARTNER/EXECUTIVE OFFICER/MEMBER EXCLUDED? (Mandatory in NH) If yes, describe under DESCRIPTION OF OPERATIONS below	Y/N	N/A	Y	POLICY NUMBER	1/1/2011	Current	<input checked="" type="checkbox"/> WC STATUTORY LIMITS <input type="checkbox"/> OTHER E.L. EACH ACCIDENT \$ 1,000,000 E.L. DISEASE - EA EMPLOYEE \$ 1,000,000 E.L. DISEASE - POLICY LIMIT \$ 1,000,000
A	Leased/Rented/Equip. Owned Equipment Builders Risk/Installation Floater	N/A	Y	POLICY NUMBER	1/1/2011	Current	Limit; Deductible Limit; Deductible Limit; Deductible	

DESCRIPTION OF OPERATIONS / LOCATIONS / VEHICLES (Attach ACORD 101, Additional Remarks Schedule, if more space is required)

Project No. \_\_\_\_\_ [Title]. Certholder (City) and \_\_\_\_\_ (Design Professional) and any other entities named in 00800 SCs are named as primary, noncontributing Additional Insureds including products and completed operations, excluding workers compensation, employers liability and professional liability. Waiver of subrogation applies as allowed by law. [The policies required above shall contain no exclusions for work expressly within the subcontractors scope of work.]

**CERTIFICATE HOLDER****CANCELLATION**

City of Kansas City, Missouri _____ [Department] _____ [Address] Kansas City, MO _____ [Zip]	SHOULD ANY OF THE ABOVE DESCRIBED POLICIES BE CANCELLED BEFORE THE EXPIRATION DATE THEREOF, NOTICE WILL BE DELIVERED IN ACCORDANCE WITH THE POLICY PROVISIONS. AUTHORIZED REPRESENTATIVE
---	---

© 1988-2010 ACORD CORPORATION. All rights reserved.



# CERTIFICATE OF LIABILITY INSURANCE

9/15/2025

DATE (MM/DD/YYYY)

08/29/2024

THIS CERTIFICATE IS ISSUED AS A MATTER OF INFORMATION ONLY AND CONFERS NO RIGHTS UPON THE CERTIFICATE HOLDER. THIS CERTIFICATE DOES NOT AFFIRMATIVELY OR NEGATIVELY AMEND, EXTEND OR ALTER THE COVERAGE AFFORDED BY THE POLICIES BELOW. THIS CERTIFICATE OF INSURANCE DOES NOT CONSTITUTE A CONTRACT BETWEEN THE ISSUING INSURER(S), AUTHORIZED REPRESENTATIVE OR PRODUCER, AND THE CERTIFICATE HOLDER.

**IMPORTANT:** If the certificate holder is an ADDITIONAL INSURED, the policy(ies) must have ADDITIONAL INSURED provisions or be endorsed. If SUBROGATION IS WAIVED, subject to the terms and conditions of the policy, certain policies may require an endorsement. A statement on this certificate does not confer rights to the certificate holder in lieu of such endorsement(s).

<b>PRODUCER</b> Lockton Companies, LLC 444 W. 47th Street, Suite 900 Kansas City MO 64112-1906 (816) 960-9000 kcasu@lockton.com	<b>CONTACT NAME:</b> PHONE: (A/C No. Ext): E-MAIL: ADDRESS:	FAX (A/C No.):
	<b>INSURER(S) AFFORDING COVERAGE</b>	
<b>INSURED</b> INFRASTRUCTURE SOLUTIONS, LLC 1504383 9801 RENNER BLVD. LENEXA KS 66219	<b>INSURER A:</b> Hartford Casualty Insurance Company <i>At</i>	NAIC # 29424
	<b>INSURER B:</b> Hartford Underwriters Insurance Company <i>At</i>	30104
	<b>INSURER C:</b> Trumbull Insurance Company <i>At</i>	27120
	<b>INSURER D:</b> American Casualty Company of Reading, PA <i>A</i>	20427
	<b>INSURER E:</b> Twin City Fire Insurance Company <i>At</i>	29459
	<b>INSURER F:</b>	

**COVERAGES**      **CERTIFICATE NUMBER: 20187836**      **REVISION NUMBER: XXXXXXXX**

THIS IS TO CERTIFY THAT THE POLICIES OF INSURANCE LISTED BELOW HAVE BEEN ISSUED TO THE INSURED NAMED ABOVE FOR THE POLICY PERIOD INDICATED. NOTWITHSTANDING ANY REQUIREMENT, TERM OR CONDITION OF ANY CONTRACT OR OTHER DOCUMENT WITH RESPECT TO WHICH THIS CERTIFICATE MAY BE ISSUED OR MAY PERTAIN, THE INSURANCE AFFORDED BY THE POLICIES DESCRIBED HEREIN IS SUBJECT TO ALL THE TERMS, EXCLUSIONS AND CONDITIONS OF SUCH POLICIES. LIMITS SHOWN MAY HAVE BEEN REDUCED BY PAID CLAIMS.

INSR LTR	TYPE OF INSURANCE	ADDL INSD	SUBR WVD	POLICY NUMBER	POLICY EFF (MM/DD/YYYY)	POLICY EXP (MM/DD/YYYY)	LIMITS
B	<input checked="" type="checkbox"/> COMMERCIAL GENERAL LIABILITY CLAIMS-MADE <input checked="" type="checkbox"/> OCCUR GEN'L AGGREGATE LIMIT APPLIES PER: <input type="checkbox"/> POLICY <input checked="" type="checkbox"/> PROJECT <input type="checkbox"/> LOC <input type="checkbox"/> OTHER:	Y	Y	37UEABG4HH8	09/15/2024	09/15/2025	EACH OCCURRENCE \$ 1,000,000 DAMAGE TO RENTED PREMISES (Ea occurrence) \$ 300,000 MED EXP (Any one person) \$ 10,000 PERSONAL & ADV INJURY \$ 1,000,000 GENERAL AGGREGATE \$ 2,000,000 PRODUCTS - COMP/OP AGG \$ 2,000,000
C	<input checked="" type="checkbox"/> AUTOMOBILE LIABILITY <input checked="" type="checkbox"/> ANY AUTO <input checked="" type="checkbox"/> OWNED AUTOS ONLY <input checked="" type="checkbox"/> HIRED AUTOS ONLY <input type="checkbox"/> SCHEDULED AUTOS <input type="checkbox"/> NON-OWNED AUTOS ONLY	Y	Y	37UEABE5HC9	09/15/2024	09/15/2025	COMBINED SINGLE LIMIT (Ea accident) \$ 1,000,000 BODILY INJURY (Per person) \$ XXXXXXXX BODILY INJURY (Per accident) \$ XXXXXXXX PROPERTY DAMAGE (Per accident) \$ XXXXXXXX
A	<input checked="" type="checkbox"/> UMBRELLA LIAB <input checked="" type="checkbox"/> OCCUR <input type="checkbox"/> EXCESS LIAB <input type="checkbox"/> CLAIMS-MADE DED      RETENTION \$	Y	Y	37RHABG4HNS	09/15/2024	09/15/2025	EACH OCCURRENCE \$ 10,000,000 AGGREGATE \$ 10,000,000 \$ XXXXXXXX
E	<b>WORKERS COMPENSATION AND EMPLOYERS' LIABILITY</b> ANY PROPRIETOR/PARTNER/EXECUTIVE OFFICER/MEMBER EXCLUDED? (Mandatory in NH) If yes, describe under DESCRIPTION OF OPERATIONS below	Y/N	N/A	37 WEA AP8C8A	09/15/2024	09/15/2025	<input checked="" type="checkbox"/> PER STATUTE <input type="checkbox"/> OTH-ER E.L. EACH ACCIDENT \$ 1,000,000 E.L. DISEASE - EA EMPLOYEE \$ 1,000,000 E.L. DISEASE - POLICY LIMIT \$ 1,000,000
D	LEASSED & RENTED EQUIP	N	Y	7018253332	09/15/2024	09/15/2025	\$500,000 LIMIT, \$5,000 DED
B	HIRED AUTO PHYS DAM	N	Y	37UEABE5HC9	09/15/2024	09/15/2025	COMP:\$5K DED; COLL:\$5K DED

DESCRIPTION OF OPERATIONS / LOCATIONS / VEHICLES (ACORD 101, Additional Remarks Schedule, may be attached if more space is required)  
 CONTRACT#: 9829 PROJECT#: 80002486 PROJECT: Emergency Water Distribution Repairs CITY OF KANSAS CITY, MISSOURI IS ADDITIONAL INSURED ON GENERAL LIABILITY, AUTOMOBILE, AND EXCESS LIABILITY ON A PRIMARY, NON-CONTRIBUTORY BASIS AS REQUIRED BY WRITTEN CONTRACT. WAIVER OF SUBROGATION IN FAVOR OF THE ADDITIONAL INSURED APPLIES ON GENERAL LIABILITY, WORKERS COMPENSATION, AUTOMOBILE, EXCESS LIABILITY, AND LEASSED/RENTED EQUIPMENT AS REQUIRED BY WRITTEN CONTRACT AND WHERE ALLOWED BY LAW. COVERAGE IS SUBJECT TO THE TERMS AND CONDITIONS OF THE POLICY

**CERTIFICATE HOLDER****CANCELLATION**

**20187836**  
 CITY OF KANSAS CITY, MISSOURI  
 WATER SERVICES DEPARTMENT  
 4800 E. 63RD STREET  
 KANSAS CITY MO 64130

SHOULD ANY OF THE ABOVE DESCRIBED POLICIES BE CANCELLED BEFORE THE EXPIRATION DATE THEREOF, NOTICE WILL BE DELIVERED IN ACCORDANCE WITH THE POLICY PROVISIONS.

AUTHORIZED REPRESENTATIVE

*[Signature]*





# CERTIFICATE OF LIABILITY INSURANCE

9/15/2025

DATE (MM/DD/YYYY)

8/29/2024

THIS CERTIFICATE IS ISSUED AS A MATTER OF INFORMATION ONLY AND CONFERS NO RIGHTS UPON THE CERTIFICATE HOLDER. THIS CERTIFICATE DOES NOT AFFIRMATIVELY OR NEGATIVELY AMEND, EXTEND OR ALTER THE COVERAGE AFFORDED BY THE POLICIES BELOW. THIS CERTIFICATE OF INSURANCE DOES NOT CONSTITUTE A CONTRACT BETWEEN THE ISSUING INSURER(S), AUTHORIZED REPRESENTATIVE OR PRODUCER, AND THE CERTIFICATE HOLDER.

IMPORTANT: If the certificate holder is an ADDITIONAL INSURED, the policy(ies) must have ADDITIONAL INSURED provisions or be endorsed. If SUBROGATION IS WAIVED, subject to the terms and conditions of the policy, certain policies may require an endorsement. A statement on this certificate does not confer rights to the certificate holder in lieu of such endorsement(s).

<b>PRODUCER</b> Lockton Companies, LLC 444 W. 47th Street, Suite 900 Kansas City MO 64112-1906 (816) 960-9000 kcasu@lockton.com	<b>CONTACT NAME:</b> <b>PHONE (A/C, No, Ext):</b>		<b>FAX (A/C, No):</b>
	<b>E-MAIL ADDRESS:</b>		
<b>INSURER(S) AFFORDING COVERAGE</b>			<b>NAIC #</b>
<b>INSURER A:</b> Continental Casualty Company <i>A</i>			20443
<b>INSURER B:</b>			
<b>INSURER C:</b>			
<b>INSURER D:</b>			
<b>INSURER E:</b>			
<b>INSURER F:</b>			

**INSURED**  
 1504389 INFRASTRUCTURE SOLUTIONS, LLC  
 9801 RENNER BLVD.  
 LENEXA KS 66219

**COVERAGES**      **CERTIFICATE NUMBER:** 20187884      **REVISION NUMBER:** XXXXXXXX

THIS IS TO CERTIFY THAT THE POLICIES OF INSURANCE LISTED BELOW HAVE BEEN ISSUED TO THE INSURED NAMED ABOVE FOR THE POLICY PERIOD INDICATED. NOTWITHSTANDING ANY REQUIREMENT, TERM OR CONDITION OF ANY CONTRACT OR OTHER DOCUMENT WITH RESPECT TO WHICH THIS CERTIFICATE MAY BE ISSUED OR MAY PERTAIN, THE INSURANCE AFFORDED BY THE POLICIES DESCRIBED HEREIN IS SUBJECT TO ALL THE TERMS, EXCLUSIONS AND CONDITIONS OF SUCH POLICIES. LIMITS SHOWN MAY HAVE BEEN REDUCED BY PAID CLAIMS.

INSR LTR	TYPE OF INSURANCE	ADDL SUBR INSD WVD	POLICY NUMBER	POLICY EFF (MM/DD/YYYY)	POLICY EXP (MM/DD/YYYY)	LIMITS
	<b>COMMERCIAL GENERAL LIABILITY</b> <input type="checkbox"/> CLAIMS-MADE <input type="checkbox"/> OCCUR  GEN'L AGGREGATE LIMIT APPLIES PER: <input type="checkbox"/> POLICY <input type="checkbox"/> PRO-JECT <input type="checkbox"/> LOC OTHER:		NOT APPLICABLE			EACH OCCURRENCE \$ XXXXXXXX DAMAGE TO RENTED PREMISES (Ea occurrence) \$ XXXXXXXX MED EXP (Any one person) \$ XXXXXXXX PERSONAL & ADV INJURY \$ XXXXXXXX GENERAL AGGREGATE \$ XXXXXXXX PRODUCTS - COMP/OP AGG \$ XXXXXXXX \$
	<b>AUTOMOBILE LIABILITY</b> <input type="checkbox"/> ANY AUTO <input type="checkbox"/> OWNED AUTOS ONLY <input type="checkbox"/> SCHEDULED AUTOS <input type="checkbox"/> HIRED AUTOS ONLY <input type="checkbox"/> NON-OWNED AUTOS ONLY <input type="checkbox"/> AUTOS ONLY		NOT APPLICABLE			COMBINED SINGLE LIMIT (Ea accident) \$ XXXXXXXX BODILY INJURY (Per person) \$ XXXXXXXX BODILY INJURY (Per accident) \$ XXXXXXXX PROPERTY DAMAGE (Per accident) \$ XXXXXXXX \$ XXXXXXXX
	<b>UMBRELLA LIAB</b> <input type="checkbox"/> OCCUR <b>EXCESS LIAB</b> <input type="checkbox"/> CLAIMS-MADE <input type="checkbox"/> DED <input type="checkbox"/> RETENTION \$		NOT APPLICABLE			EACH OCCURRENCE \$ XXXXXXXX AGGREGATE \$ XXXXXXXX \$ XXXXXXXX
	<b>WORKERS COMPENSATION AND EMPLOYERS' LIABILITY</b> ANY PROPRIETOR/PARTNER/EXECUTIVE OFFICER/MEMBER EXCLUDED? (Mandatory in NH) If yes, describe under DESCRIPTION OF OPERATIONS below	<input type="checkbox"/> Y/N    N/A	NOT APPLICABLE			<input type="checkbox"/> PER STATUTE <input type="checkbox"/> OTH-ER E.L. EACH ACCIDENT \$ XXXXXXXX E.L. DISEASE - EA EMPLOYEE \$ XXXXXXXX E.L. DISEASE - POLICY LIMIT \$ XXXXXXXX
A	<b>BUILDERS RISK</b>	Y    Y	6080031905	9/15/2024	9/15/2025	LIMITS SHOWN BELOW

**SURETY VERIFIED**  
 BY *Debra Moore* 9/10/24

**DESCRIPTION OF OPERATIONS / LOCATIONS / VEHICLES (ACORD 101, Additional Remarks Schedule, may be attached if more space is required)**  
 CONTRACT#: 9829  
 PROJECT#: 80002486  
 PROJECT: Emergency Water Distribution Repairs  
 CITY OF KANSAS CITY, MISSOURI IS ADDITIONAL INSURED ON BUILDERS RISK, IF REQUIRED BY WRITTEN CONTRACT AND SUBJECT TO THE TERMS AND CONDITIONS OF THE POLICY. WAIVER OF SUBROGATION IN FAVOR OF CITY OF KANSAS CITY, MISSOURI APPLIES ON BUILDERS RISK AS REQUIRED BY WRITTEN CONTRACT AND WHERE ALLOWED BY LAW. COVERAGE IS SUBJECT TO THE TERMS AND CONDITIONS OF THE POLICY

<b>CERTIFICATE HOLDER</b>  <b>20187884</b> CITY OF KANSAS CITY, MISSOURI WATER SERVICES DEPARTMENT 4800 E 63RD STREET KANSAS CITY MO 64130	<b>CANCELLATION</b> See Attachment  SHOULD ANY OF THE ABOVE DESCRIBED POLICIES BE CANCELLED BEFORE THE EXPIRATION DATE THEREOF, NOTICE WILL BE DELIVERED IN ACCORDANCE WITH THE POLICY PROVISIONS.  AUTHORIZED REPRESENTATIVE <i>Joseph M. Agrella</i>
--	---

Blanket Master Builders Risk

Construction Type	Hard Cost	Business Income
Frame, PPC 1 through 10	\$5,000,000	\$250,000
Joisted Masonry, PPC 1 through 10	\$10,000,000	\$250,000
Metal Non-Combustible, PPC 1 through 10	\$35,000,000	\$250,000
Masonry Non-Combustible, PPC 1 through 10	\$35,000,000	\$250,000
Fire-Resistive, PPC 1 through 10	\$35,000,000	\$250,000
Street and Road Bridge Construction	\$10,000,000	\$150,000
Street and Road Non Bridge Construction	\$10,000,000	\$150,000
Water & Sewer Line Construction	\$25,000,000	\$150,000
Storm Water Rehab Projects	\$25,000,000	\$150,000

Earthquake:

- Low Hazard: \$1,000,000 occurrence/\$5,000,000 aggregate; \$25,000 deductible
- Critical Hazard: \$1,000,000 occurrence/aggregate; \$100,000

Flood:

- High Hazard: \$250,000 per occurrence/ \$1,000,000 aggregate
  - o \$250,000 deductible
- Moderate Hazard: \$500,000 per occurrence/\$5,000,000 aggregate
  - o \$100,000 deductible
- Low Hazard: \$1,000,000 per occurrence/ \$5,000,000 aggregate
  - o \$25,000 deductible

Deductibles:

- All other perils: \$5,000
- Equipment Breakdown: \$5,000
- Operational Testing: \$5,000
- Property In Transit: \$5,000



KANSAS CITY  
MISSOURI

Finance Department

Revenue Division

414 E 12th St. 1st Floor  
Kansas City, MO 64106-2786

Phone: (816) 513-1120  
Fax: (816) 513-1264  
Email: [revenue@kcmo.org](mailto:revenue@kcmo.org)  
Website: [kcmo.gov/tax](http://kcmo.gov/tax)

Letter Id: L0739595008  
Date: 30-Jun-2023  
Taxpayer Id: \*\*-\*\*\*3660

INFRASTRUCTURES SOLUTIONS, LLC  
9801 RENNER BLVD  
LENEXA KS 66219-9718



## TAX CLEARANCE STATUS: APPROVED

As of this date, this notice is to inform you that INFRASTRUCTURES SOLUTIONS, LLC is current with all taxes and license fees with the City of Kansas City, Mo., Finance Department/ Revenue Division.

Please note this could change if we perform a full review of your accounts in the future. We will let you know if we need to review your accounts. You will need to pay any amounts that are found due at that time.

Mari Ruck  
Commissioner of Revenue

Visit [kcmo.gov/quicktax](http://kcmo.gov/quicktax) to view the status of your account and for online filing.





# AUTHORIZATION TO RELEASE A REVENUE CLEARANCE LETTER

Revenue Division  
414 East 12<sup>th</sup> Street, 2<sup>nd</sup> floor, Room 202 W  
Kansas City, MO 64106 Phone (816) 513-1135 Fax (816) 513-1077 email: revenue@kcmo.org

I authorize the City of Kansas City, Missouri, Finance Department, Revenue Division, to release a Revenue Clearance Letter for:

Name of Taxpayer: \_\_\_\_\_ Tax I.D.# \_\_\_\_\_  
*(PRINT)*

Address: \_\_\_\_\_

**Check this box and the City will send the Clearance Letter to you or the contractor designated.**

I authorize the City to provide a copy of the Taxpayer's Revenue Clearance Letter to the following:

NAME <i>(PRINT)</i>	BUSINESS NAME	TITLE
ADDRESS	CITY, STATE, ZIP CODE	
PHONE NUMBER	FAX NUMBER	E-MAIL ADDRESS

I authorize the City to provide the Taxpayer's Revenue Clearance Letter to all City Departments and to publish on the City's internet/intranet website that the Taxpayer is in compliance with the tax ordinances administered by the City's Commissioner of Revenue.

Please send my 1<sup>st</sup> Revenue Clearance Letter to: \_\_\_\_\_  
*(Print Name of City Department/Contact Person/E-mail/Fax Number)*

This authorization shall expire one (1) year from the date of the signature.

The City, Commissioner of Revenue and the Revenue Division personnel (hereinafter "the City"), are hereby held harmless from any and all liability relating to unauthorized disclosure of confidential tax information resulting from release of information under all applicable confidentiality laws including federal, state, or local including any damages sustained by wrongful transmission of confidential tax information to any other person.

UNDER PENALTIES OF PERJURY, I DECLARE THAT I HAVE EXAMINED THIS AUTHORIZATION, AND TO THE BEST OF MY KNOWLEDGE AND BELIEF, IT IS TRUE, CORRECT AND COMPLETE.

**I hereby certify that I am the Taxpayer named herein or that I have the authority to execute this authorization and hold harmless agreement on behalf of the Taxpayer.**

NAME <i>(PRINT)</i>	TITLE <i>(IF APPLICABLE)</i>	
SIGNATURE	PHONE NUMBER	DATE

**A FACSIMILE OF THIS DOCUMENT SHALL CONSTITUTE AN ORIGINAL**



## **GENERAL CONDITIONS TABLE OF CONTENTS**

### **ARTICLE 1 DEFINITIONS AND TERMINOLOGY**

- 1.01 Defined Terms
- 1.02 Terminology

### **ARTICLE 2 PRELIMINARY MATTERS**

- 2.01 Delivery of Bonds
- 2.02 Evidence of Insurance
- 2.03 Copies of Documents
- 2.04 Commencement of Contract Times; Notice to Proceed
- 2.05 Starting the Work
- 2.06 Before Starting Construction
- 2.07 Initially Acceptable Schedules

### **ARTICLE 3 CONTRACT DOCUMENTS: INTENT, AMENDING, REUSE**

- 3.01 Intent
- 3.02 Reference to Standards and Specifications of Technical Societies
- 3.03 Reporting and Resolving Discrepancies
- 3.04 Amending and Supplementing Contract Documents
- 3.05 Reuse of Documents

### **ARTICLE 4 AVAILABILITY OF LANDS; SUBSURFACE AND PHYSICAL CONDITIONS; REFERENCE POINTS**

- 4.01 Availability of Lands
- 4.02 Subsurface and Physical Conditions
- 4.03 Differing Subsurface or Physical Conditions
- 4.04. Physical Conditions - Underground Facilities
- 4.05 Reference Points
- 4.06 Asbestos, Lead-Based Paint, PCBs, Petroleum, Hazardous Waste or Radioactive Material

### **ARTICLE 5 BONDS AND INSURANCE**

- 5.01 Performance, Payment and Other Bonds
- 5.02 Licensed Sureties and Insurers
- 5.03 Certificates of Insurance
- 5.04 CONTRACTOR's Liability Insurance
- 5.05 CITY's Liability Insurance
- 5.06 Property Insurance
- 5.07 Waiver of Rights
- 5.08 Receipt and Application of Insurance Proceeds
- 5.09 Partial Utilization - Property Insurance

### **ARTICLE 6 CONTRACTOR'S RESPONSIBILITIES**

- 6.01 Indemnification

- 6.02 Supervision and Superintendence
- 6.03 Services, Working Hours, Labor, Materials and Equipment
- 6.04 Progress Schedule
- 6.05 Recovery Schedules
- 6.06 Substitutes and "Or-Equal" Items
- 6.07 Concerning Subcontractors, Suppliers and Others
- 6.08 Patent Fees and Royalties
- 6.09 Permits
- 6.10 Laws or Regulations
- 6.11 Taxes
- 6.12 Use of Site and Other Areas
- 6.13 Record Documents
- 6.14 Safety and Protection
- 6.15 Safety Representative
- 6.16 Hazard Communication Programs
- 6.17 Emergencies
- 6.18 Shop Drawings and Samples
- 6.19 Continuing the Work
- 6.20 CONTRACTOR's General Warranty and Guarantee

#### **ARTICLE 7 OTHER WORK**

- 7.01 Related Work at Site
- 7.02 Coordination

#### **ARTICLE 8 CITY's RESPONSIBILITIES**

- 8.01 Communications to CONTRACTOR
- 8.02 Replacement of DESIGN PROFESSIONAL
- 8.03 Furnish Data and Prompt Payment
- 8.04 Lands and Easements; Reports and Tests
- 8.05 Insurance
- 8.06 Change Orders
- 8.07 Inspections, Tests and Approvals
- 8.08 Limitations on CITY's Responsibilities
- 8.09 Undisclosed Hazardous Environmental Condition
- 8.10 Evidence of Financial Arrangements
- 8.11 CITY's Representative
- 8.12 Visits to Site

#### **ARTICLE 9 DESIGN PROFESSIONAL's STATUS DURING CONSTRUCTION**

- 9.01 General Scope of DESIGN PROFESSIONAL's Duties
- 9.02 Resident Project Representative
- 9.03 Clarifications and Interpretations
- 9.04 Rejecting Defective Work
- 9.05 Shop Drawings, Change Orders and Payments
- 9.06 Determinations for Unit Prices
- 9.07 Decisions on Requirements of Contract Documents and Acceptability of Work
- 9.08 Limitations on DESIGN PROFESSIONAL's Authority and Responsibilities

#### **ARTICLE 10 CHANGES IN THE WORK**

- 10.01 Authorized Changes in the Work
- 10.02 Unauthorized Changes in the Work
- 10.03 Execution of Change Orders
- 10.04 Notification to Surety

## **ARTICLE 11 CHANGE OF CONTRACT PRICE**

- 11.01 Change of Contract Price
- 11.02 Cost of the Work
- 11.03 Cash Allowances
- 11.04 Unit Price Work
- 11.05 Dispute Resolution

## **ARTICLE 12 CONTRACT TIMES**

- 12.01 Time of the Essence
- 12.02 Change of Contract Times
- 12.03 Proof Required To Justify An Extension of Time For Excusable and Compensable Delays
- 12.04 Delays Within CONTRACTOR's Control
- 12.05 Delays Beyond the CITY's and CONTRACTOR's Control
- 12.06 Delay Damages
- 12.07 Dispute Resolution

## **ARTICLE 13 TESTS AND INSPECTIONS; CORRECTION, REMOVAL OR ACCEPTANCE OF DEFECTIVE WORK**

- 13.01 Access to Work
- 13.02 Tests and Inspections
- 13.03 Notice of Defects
- 13.04 Uncovering Work
- 13.05 CITY May Stop the Work
- 13.06 Correction or Removal of Defective Work
- 13.07 Correction Period
- 13.08 Acceptance of Defective Work
- 13.09 CITY May Correct Defective Work

## **ARTICLE 14 PAYMENTS TO CONTRACTOR AND COMPLETION**

- 14.01 Schedule of Values
- 14.02 Application for Progress Payments
- 14.03 Contractor's Warranty of Title
- 14.04 Substantial Completion
- 14.05 Partial Utilization
- 14.06 Final Inspection
- 14.07 Final Payment
- 14.08 Final Completion Delayed
- 14.09 Waiver of Claims
- 14.10 Completion of Work by City

## **ARTICLE 15 SUSPENSION OF WORK AND TERMINATION**

- 15.01 CITY May Suspend Work
- 15.02 CITY May Terminate for Default
- 15.03 CITY May Terminate for Convenience

## **ARTICLE 16 CLAIMS AND DISPUTES**

- 16.01 Definition
- 16.02 Written Notice and Burden of Proof
- 16.03 Time Limits on Claims
- 16.04 Continuing Contract Performance
- 16.05 Injury or Damage to Person or Property
- 16.06 Initial Resolution of Claims and Disputes

16.07 Final Resolution of Claims and Disputes

**ARTICLE 17 MISCELLANEOUS**

17.01 Giving Notice

17.02 Computation of Times

17.03 Cumulative Remedies

17.04 Survival of Obligations

17.05 Controlling Law



## ARTICLE 1 DEFINITIONS AND TERMINOLOGY

### 1.01 Defined Terms

A. Wherever used in these General Conditions or in the other Contract Documents, the following terms have the meanings indicated which are applicable to both the singular and plural thereof:

**1. Addenda** - Written or graphic instruments issued prior to the opening of Bids that clarify, correct or change the Bidding Requirements or the Contract Documents.

**2. Agreement**—The written Contract between CITY and CONTRACTOR governing the Work to be performed; other Contract Documents are attached to the Agreement and made a part thereof as provided therein.

**3. Application for Payment**—The form accepted by CITY's Representative which is to be used by CONTRACTOR in requesting progress or final payments and which is to be accompanied by such supporting documentation as is required by the Contract Documents.

**4. Asbestos** - Any material that contains more than one percent (1%) Asbestos and is friable or is releasing Asbestos fibers into the air above current action levels established by the United States Occupational Safety and Health Administration.

**5. Bid**- The offer or proposal of the Bidder submitted on the Bid Form/Contract setting forth the prices for the Work to be performed. A Bidder's Bid becomes a Contract with CITY if the CITY executes the Bid Form/Contract submitted by Bidder. If the CITY executes the Bid Form/Contract submitted by Bidder, the term "Bidder" shall mean CONTRACTOR.

**6. Bidder**- One who submits a Bid directly to CITY, as distinct from a sub-bidder who submits a bid to a Bidder. If the CITY executes the Bid Form/Contract submitted by Bidder, the term "Bidder" shall mean CONTRACTOR in both the Bidding Documents and Contract Documents unless the context clearly indicates otherwise.

**7. Bidding Documents**- The advertisement or Invitation to Bid, Instructions to Bidders, the Bid Form/Contract, and the proposed Contract Documents (including all Addenda issued prior to receipt of Bids).

**8. Bidding Requirements**- The advertisement or invitation to bid, Instructions to Bidders, Bid security, and the Bid Form/Contract with any supplements.

**9. Bonds**- Payment Bond and Performance and Maintenance Bond and other instruments of security.

**10. Calendar Day**- Any day shown on the calendar, including Saturdays, Sundays, and holidays.

**11. Change Order**- A written document issued by CITY that authorizes an addition, deletion or revision in the Work, or an adjustment in the Contract Price or the Contract Times, issued on or after the Effective Date of the Contract.

**12. CITY/OWNER**- Kansas City, Missouri, a constitutionally chartered municipal corporation, with which CONTRACTOR has entered into the Contract and for whom the Work is to be provided.

**13. CITY's Representative**- Person or agency designated to act for the Director as provided in these Contract Documents.

**14. Consultant**- Person, firm or corporation having a contract with CITY or DESIGN PROFESSIONAL to furnish services as an independent professional associate or Consultant with respect to the Project and who's identified as such in the Supplementary Conditions.

The Consultant(s) is identified and their seals affixed on the Certification Page(s). The certifications describe the respective responsibilities for the Drawings and Specifications prepared by the Consultant(s) and are incorporated into this Contract.

**15. Contract-** The entire and integrated written agreement between CITY and CONTRACTOR concerning the Work that incorporates all Contract Documents. The Bid Form/Contract submitted by Bidder is the Contract between CITY and CONTRACTOR upon execution by CITY. The Contract supersedes prior negotiations, representations, or agreements, whether written or oral.

**16. Contract Documents-** The Contract Documents establish the rights and obligations of the parties and include the Contract, Addenda (which pertain to the Contract Documents), CONTRACTOR's Bid Form/Contract (including documentation accompanying the Bid and any post Bid documentation submitted prior to the Notice of Intent to Contract), the Construction Project Instructions, the Contractor's Utilization Plan/Request for Waiver, the Notice to Proceed, the Bonds, these General Conditions, the Supplementary Conditions, the Specifications and the Drawings as the same are more specifically identified in the Project Manual and the certification page(s) of the DESIGN PROFESSIONAL and Consultant(s), together with approved project baseline schedule and amendments thereto and all Written Amendments, Change Orders, Work Change Directives, and DESIGN PROFESSIONAL's written interpretations and clarifications issued on or after the Effective Date of the Contract, and approved Shop Drawings. Reports and drawings of subsurface and physical conditions are not Contract Documents. Only printed or hard copies of the items listed in this Paragraph are Contract Documents. Files in electronic media format of text, data, graphics, and the like that may be furnished by CITY to CONTRACTOR are not Contract Documents, except project schedules submitted by CONTRACTOR and approved by CITY.

**17. Contract Price-** The money payable by CITY to CONTRACTOR for completion of the Work in accordance with the Contract Documents as stated in the Agreement.

**18. Contract Times-** The number of days or the dates stated in the Supplementary Conditions: (a) to achieve Substantial Completion, and (b) to complete the Work so that it is ready for final payment as evidenced by CITY's Representative's written recommendation of final payment.

**19. CONTRACTOR-** The person, firm, partnership, company, corporation or association licensed or otherwise authorized by law to do business in Missouri, with whom CITY has entered into the Agreement.

**20. Day-** Shall constitute a Calendar Day.

**21. DESIGN PROFESSIONAL-** Architect, Engineer or other licensed professional who is either employed by or has contracted with CITY to serve in a design capacity and whose Consultants, members, partners, employees or agents have prepared and sealed the Drawings and Specifications.

The DESIGN PROFESSIONAL(s) is identified and their seals affixed on the Certification Page(s). The certifications describe the respective responsibilities for the Drawings and Specifications prepared by the DESIGN PROFESSIONAL and are incorporated into this Contract.

**22. DESIGN PROFESSIONAL's Project Representative-** The authorized representative of DESIGN PROFESSIONAL who may be assigned to the Site or any part thereof.

**23. Director-** The term Director shall mean the duly appointed executive officer of a department of City who is empowered by the City Charter or by the City Council to enter into a contract on behalf of City, or to grant a permit for improvements to land owned by City. A Director is authorized to delegate this authority to a City employee so designated in writing.

**24. Drawings-** The drawings which graphically show the scope, extent and character of the Work to be furnished and performed by CONTRACTOR and which have been prepared by DESIGN PROFESSIONAL and are included in the Contract Documents. Shop Drawings are not Drawings as so defined.

**25. Effective Date of the Contract-** The date indicated in the Contract on which it becomes effective, but if no such date is indicated it means the date on which the Contract is fully executed by CITY.

**26. General Requirements-** Sections of Division 1 of the Specifications. The General Requirements pertain to all sections of the Specifications.

**27. Hazardous Environmental Condition-** The presence at the Site of Asbestos, Lead-Based Paint, PCBs, Petroleum, Hazardous Waste, or Radioactive Material in such quantities or circumstances that may present a substantial danger to persons or property exposed thereto in connection with the Work.

**28. Hazardous Waste-** The term Hazardous Waste shall have the meaning provided in Section 1004 of the Solid Waste Disposal Act (42 USC Section 6903) as amended from time to time.

**29. Laws or Regulations-** Any and all applicable laws, rules, regulations, ordinances, codes and orders of any and all governmental bodies, agencies, authorities and courts having jurisdiction.

**30. Lead-Based Paint-** Any paint, varnish, stain, or other applied coating that has one (1) mg or more of lead per square centimeter. The terms "leaded paint" and "lead-containing paint" are synonymous with Lead-Based Paint.

**31. Liens-** Liens, charges, security interests or encumbrances upon real property or personal property.

**32. Milestone-** A principal event specified in the Contract Documents relating to an intermediate completion date or time prior to Substantial Completion of all the Work.

**33. Notice of Intent to Contract-** The written notice by CITY to the apparent successful Bidder stating that upon compliance by that apparent successful Bidder with the conditions in the Bid Documents enumerated, within the time specified, and upon enactment of an appropriate ordinance or resolution, CITY will sign and deliver the Contract.

**34. Notice to Proceed-** A written notice given by CITY to CONTRACTOR fixing the date on which the Contract Times will commence to run and on which CONTRACTOR shall start to perform CONTRACTOR's obligations under the Contract Documents.

**35. Partial Utilization-** Use by CITY of a substantially completed part of the Work for the purpose for which it is intended (or a related purpose) prior to Substantial Completion of all the Work.

**36. PCBs-** Polychlorinated biphenyls.

**37. Petroleum-** Petroleum, including crude oil or any fraction thereof which is liquid at standard conditions of temperature and pressure (60 degrees Fahrenheit and 14.7 pounds per square inch absolute), such as oil, petroleum, fuel oil, oil sludge, oil refuse, gasoline, kerosene, and oil mixed with other non-Hazardous Wastes and crude oils.

**38. Project-** The total construction of which the Work to be provided under the Contract Documents may be the whole, or a part as indicated elsewhere in the Contract Documents.

**39. Project Manual-** The documentary information prepared for bidding and constructing the Work. A listing of the contents of the Project Manual may be issued in one or more volumes and is contained in the table(s) of contents.

**40. Radioactive Material-** Source, special nuclear, or byproduct material as defined by the Atomic Energy Act of 1954 (42 USC Section 2011 et seq.) as amended from time to time.

**41. Samples-** Physical examples of materials, equipment, or workmanship that are representative of some portion of the Work and which establish the standards by which such portion of the Work will be judged.

**42. Shop Drawings-** All drawings, diagrams, illustrations, schedules and other data or information which are specifically prepared or assembled by or for CONTRACTOR and submitted by CONTRACTOR to illustrate some portion of the Work.

**43. Site-** Lands or areas indicated in the Contract Documents as being furnished by CITY upon which the Work is to be performed, including rights-of-way and easements for access thereto, and such other lands furnished by CITY which are designated for the use of CONTRACTOR.

**44. Specifications-** Those portions of the Contract Documents consisting of written technical descriptions of materials, equipment, construction systems, standards and workmanship as applied to the Work and certain administrative details applicable thereto.

**45. Subcontractor-** Any individual, firm, partnership, company, corporation or association licensed or otherwise authorized by law to do business in Missouri, to whom CONTRACTOR, with written notification to CITY, has entered into an agreement to perform a part of the Work.

**46. Substantial Completion-** When Work (or a specified part thereof) has progressed to the point where, in the opinion of DESIGN PROFESSIONAL as evidenced by DESIGN PROFESSIONAL's definitive certificate of Substantial Completion, it is sufficiently complete, in accordance with the Contract Documents, so that the Work (or specified part) can be utilized for the purposes for which it is intended. The terms "substantially complete" and "substantially completed" as applied to all or part of the Work refer to Substantial Completion thereof.

**47. Supplementary Conditions-** The part of the Contract Documents which amends and/or supplements these General Conditions.

**48. Supplier-** A manufacturer, fabricator, supplier, distributor, materialman or vendor having a direct contract with CONTRACTOR or with any Subcontractor to furnish materials or equipment to be incorporated into the Work by CONTRACTOR or any Subcontractor.

**49. Underground Facilities-** All pipelines, conduits, ducts, cables, wires, manholes, vaults, tanks, tunnels or other such facilities or attachments, and any encasements containing such facilities which have been installed underground to furnish any of the following services or materials: electricity, gases, steam, liquid petroleum products, telephone or other communications, cable television, water, wastewater, storm water, other liquids or chemicals, or traffic or other control systems.

**50. Unit Price Work-** Work to be paid for on the basis of unit prices.

**51. Work-** The entire completed construction or the various separately identifiable parts thereof required to be furnished under the Contract Documents. Work includes and is the result of performing or furnishing labor, and furnishing and incorporating material and equipment into the construction, and furnishing documents, all as required by the Contract Documents.

**52. Work Change Directive-** A written directive to CONTRACTOR, issued on or after the Effective Date of the Contract, signed by CITY and recommended by DESIGN PROFESSIONAL, ordering an addition, deletion or revision in the Work, or responding to differing or unforeseen subsurface or physical conditions under which the Work is to be performed, or to emergencies. A Work Change Directive will not change the Contract Price or the Contract Times, but is evidence that the parties expect that the change directed or

documented by a Work Change Directive will be incorporated in a subsequently issued Change Order following negotiations by the parties as to its effect, if any, on the Contract Price or Contract Times.

**53. Work Day** - Any day during which the CONTRACTOR is able to work a period of six (6) hours or more. Days that are not Work Days are days during which the CONTRACTOR is unable to work for a period of six (6) hours by reason of strikes, boycotts, labor disputes, embargoes, unusual delays in transportation or shortage of material, acts of God, acts of the public enemy, acts of superior governmental authority, weather conditions, riots, rebellion, sabotage, or any other circumstances for which CONTRACTOR is not responsible or which is not within its control. Saturdays, Sundays, and holidays on which the CONTRACTOR's forces engage in Work requiring the presence of an inspector, will be considered as Work Days.

**54. Written Amendment-** A written statement modifying the Contract Documents, signed by CITY and CONTRACTOR on or after the Effective Date of the Contract and normally dealing with the non-engineering or non-technical rather than strictly construction-related aspects of the Contract Documents.

## **1.02 Terminology**

### **A. Intent of Certain Terms or Adjectives**

1. Whenever in the Contract Documents the terms "as ordered," "as directed," "as required," "as allowed," "as approved," or terms of like effect or import are used, or the adjectives "reasonable," "suitable," "acceptable," "proper" or "satisfactory" or adjectives of like effect or import are used to describe a requirement, direction, review or judgment of DESIGN PROFESSIONAL as to the Work, it is intended that such requirement, direction, review or judgment will be solely to evaluate, in general, the completed Work for compliance with the requirements of and information in the Contract Documents and conformance with the design concept of the completed Project as a functioning whole as shown or indicated in the Contract Documents (unless there is a specific statement indicating otherwise). The use of any such term or adjective shall not be effective to assign to DESIGN PROFESSIONAL any duty or authority to supervise or direct the furnishing or performance of the Work or any duty or authority to undertake responsibility contrary to the provisions of Paragraph 9.08 or any other provision of the Contract Documents.

### **B. Defective**

1. The word "defective," when modifying the word "Work," refers to Work that is unsatisfactory, faulty or deficient, in that it does not conform to the Contract Documents, or does not meet the requirements of any inspection, reference standard, test or approval referred to in the Contract Documents, or has been damaged prior to CITY 's Representative's recommendation of final payment (unless responsibility for the protection thereof has been assumed by CITY at Substantial Completion in accordance with Paragraph 14.04 or 14.05).

### **C. Furnish, Install, Perform, Provide**

1. The word "furnish," when used in connection with services, materials, or equipment, shall mean to supply and deliver said services, materials, or equipment to the Site (or some other specified location) ready for use or installation and in usable or operable condition.

2. The word "install," when used in connection with services, materials, or equipment, shall mean to put into use or place in final position said services, materials, or equipment complete and ready for intended use.

3. The words "perform" or "provide," when used in connection with services, materials, or equipment, shall mean to furnish and install said services, materials, or equipment complete and ready for intended use.

4. When “furnish,” “install,” “perform,” or “provide” is not used in connection with services, materials, or equipment in a context clearly requiring an obligation of CONTRACTOR, “provide” is implied.

D. Unless stated otherwise in the Contract Documents, words and phrases which have a well-known technical or construction industry or trade meanings are used in the Contract Documents in accordance with such recognized meaning.

## **ARTICLE 2 PRELIMINARY MATTERS**

### **2.01 Delivery of Bonds**

A. CONTRACTOR shall deliver to CITY such Bonds as CONTRACTOR may be required to furnish.

### **2.02 Evidence of Insurance**

A. CONTRACTOR shall deliver to CITY certificates of insurance or other evidence of insurance that CITY may request, which CONTRACTOR is required to purchase and maintain in accordance with Article 5 or any other applicable provision in the Contract Documents.

### **2.03 Copies of Documents**

A. CITY shall furnish to CONTRACTOR one (1) copy of the Drawings and Specifications, including addenda.

### **2.04 Commencement of Contract Times; Notice to Proceed**

A. The Contract Times will commence to run on the date indicated in the Notice to Proceed.

### **2.05 Starting the Work**

A. CONTRACTOR shall start to perform the Work on the date when the Contract Times commence to run, but no Work shall be done at the Site prior to the date on which the Contract Times commence to run, unless otherwise indicated in the Notice to Proceed.

### **2.06 Before Starting Construction**

A. CONTRACTOR's Review of Contract Documents: Before undertaking each part of the Work, CONTRACTOR shall carefully study and compare the Contract Documents and check and verify pertinent figures shown thereon and all applicable field measurements. CONTRACTOR shall promptly report in writing to DESIGN PROFESSIONAL any conflict, error, ambiguity or discrepancy which CONTRACTOR may discover and shall obtain a written interpretation or clarification from DESIGN PROFESSIONAL before proceeding with any Work affected thereby. CONTRACTOR shall not be liable to CITY or DESIGN PROFESSIONAL for failure to report any conflict, error, ambiguity or discrepancy in the Contract Documents, unless CONTRACTOR knew or reasonably should have known thereof.

B. Preliminary Schedules: Within ten (10) days after the Effective Date of the Contract, or on such later date as CITY's Representative shall provide in writing, CONTRACTOR shall submit to CITY's Representative for review:

1. Preliminary Project Schedule: CONTRACTOR shall submit a proposed project schedule for CITY's acceptance. The proposed project schedule shall include a detailed and comprehensive construction schedule utilizing a critical path method diagram network that (a) shows all major procurement and construction elements and phases of the Project; (b) breaks down each element or phase by trade; (c) shows early and late starts so that all float time will be accurately identified; (d) all other activities necessary for the timely completion of the Project in accordance with the scheduled dates for Substantial and Final Completion; and (e) highlights the project's critical path. CITY's acceptance is expressly limited to CITY's acknowledgement that, based upon CITY's limited review, the dates of Substantial

Completion and Milestone dates are acceptable. After final acceptance of the preliminary project schedule by the CITY, it shall be considered the project baseline schedule pursuant to Paragraph 2.07(B).

2. Preliminary schedule of Shop Drawings and Sample submittals which will list each required submittal and the times for submitting, reviewing and processing such submittal; and

3. Preliminary 01290.02 Schedule of Values for all of the Work which will include quantities and prices of items which when added together equals the Contract Price and will subdivide the Work into component parts in sufficient detail to serve as the basis for progress payments during performance of the Work. Such prices will include an appropriate amount of overhead and profit applicable to each item of Work.

**C.** Preconstruction Conference: Before any Work at the Site may be started, a conference attended by CONTRACTOR, DESIGN PROFESSIONAL and others, as appropriate, will be scheduled by CITY's Representative to establish a working understanding among the parties as to the Work and to discuss the schedules referred to in Paragraph 2.06 B, procedures for handling Shop Drawings and other submittals, processing Applications for Payment, maintaining required records, Claims process, dispute resolution or any other applicable provisions of the Contract Documents.

## **2.07 Acceptable Schedules**

**A.** Acceptable schedule: The Contractor shall update and submit to the CITY for review the preliminary schedule within seven (7) Calendar Days after the Notice to Proceed.

1. The CITY shall review and make any necessary comments and/or adjustments to the updated preliminary schedule. The Contractor shall incorporate the CITY's comments and resubmit the updated preliminary schedule within seven (7) Calendar Days from receipt of the CITY's comments.

**B.** Project Baseline Schedule: The accepted updated preliminary schedule shall be considered the project baseline schedule and shall be used by the CONTRACTOR for planning, scheduling, managing, and executing the Work. The project baseline schedule shall not be changed without the written consent of CITY. The project baseline schedule may be further modified by the Supplemental Conditions.

**C.** CONTRACTOR's schedule of values will be acceptable to CITY's Representative as to form and substance if it provides a reasonable allocation of the Contract Price to component parts of the Work.

## **ARTICLE 3 CONTRACT DOCUMENTS : INTENT, AMENDING, REUSE**

### **3.01 Intent**

**A.** The Contract Documents comprise the entire Contract between CITY and CONTRACTOR concerning the Work.

**B.** It is the intent of the Contract Documents to describe a functionally complete Project (or part thereof) to be constructed in accordance with the Contract Documents. Any Work, materials or equipment that may reasonably be inferred from the Contract Documents or from prevailing custom or trade usage as being required to produce the intended result will be furnished and performed whether or not specifically called for at no additional cost to CITY. Clarifications and interpretations of the Contract Documents shall be issued by DESIGN PROFESSIONAL as provided in Paragraph 9.03.

**C.** Correlation and intent of documents: The Drawings and Specifications are intended to supplement each other. Any Work shown on the Drawings and not mentioned in the Specifications (or vice versa) shall be as binding and shall be completed the same as if mentioned or shown on both. In the event of conflicts or discrepancies among the Contract Documents, interpretations will be based on the following priorities:

1. Change Orders and Written Amendments
2. Project Baseline Schedule Requirements
3. Approved Shop Drawings
4. Addenda, with those of later date having precedence over those of earlier date
5. The Supplementary Conditions
6. The General Conditions
7. Drawings and Specifications

**D.** In the case of an inconsistency between Drawings and Specifications, the requirements of the Specifications shall govern. If Drawings are in conflict, larger scale details shall govern over smaller or no-scale Drawings. If Specification sections are in conflict with each other, the conflict shall be resolved by DESIGN PROFESSIONAL in accordance with reasonable interpretation of such documents.

**E.** The general character of the detailed Work is shown on the Drawings, but minor modifications may be made in the full size or scale details. Where the word "similar" occurs on the Drawings, it shall be used in its general sense and not as meaning identical, and all details shall be worked out in relation to their location and their connection to the other parts of the Work. Where on any Drawings a portion of the Work is drawn out and the remainder is indicated in outline, the parts drawn out shall apply also to all other like portions of the Work. Where ornaments or other details are indicated by starting only, such details shall be continued throughout the courses or parts in which they occur and shall also apply to all other similar parts in the Work, unless otherwise indicated.

### **3.02 Reference to Standards and Specifications of Technical Societies**

**A.** Reference to standards, specifications, manuals or codes of any technical society, organization or association, or to Laws or Regulations, whether such reference be specific or by implication, shall mean the latest standard, specification, manual, code or Laws or Regulations in effect at the time of opening of Bids (or on the date of CONTRACTOR's proposal if there are no Bids), except as may be otherwise specifically stated in the Contract Documents.

1. No provision of any such standard, specification, manual, code or instruction of Supplier shall be effective to change the duties or responsibilities of CITY, CONTRACTOR or DESIGN PROFESSIONAL, or any of their Subcontractors, Consultants, agents, or employees from those set forth in the Contract Documents, nor shall it be effective to assign to CITY or DESIGN PROFESSIONAL or any of their Consultants, agents or employees any duty or authority to supervise or direct the furnishing or performance of the Work or any duty or authority to undertake responsibility inconsistent with the provisions of the Contract Documents.

### **3.03 Reporting and Resolving Discrepancies**

**A. Reporting Discrepancies:** If, during the performance of the Work, CONTRACTOR discovers any conflict, error, ambiguity or discrepancy within the Contract Documents or between the Contract Documents and any provision of any Laws or Regulations applicable to the performance of the Work or of any standard, specification, manual, code or any instruction of any Supplier referred to in Paragraph 6.07, CONTRACTOR shall report it immediately to DESIGN PROFESSIONAL in writing. CONTRACTOR shall not proceed with the Work affected thereby (except in an emergency as authorized by Paragraph 6.17) until an amendment or supplement to the Contract Documents has been issued by one of the methods indicated in Paragraph 3.04; provided, however, that CONTRACTOR shall not be liable to CITY or DESIGN PROFESSIONAL for failure to report any such conflict, error, ambiguity or discrepancy unless CONTRACTOR knew or reasonably should have known thereof.



**B. Resolving Discrepancies.** The provisions of the Contract Documents shall take precedence in resolving any conflict, error, ambiguity or discrepancy between the provisions of the Contract Documents and:

1. the provisions of any standard, specification, manual, code or instruction (whether or not specifically incorporated by reference in the Contract Documents); or
2. the provisions of any Laws or Regulations applicable to the performance of the Work.

### **3.04 Amending and Supplementing Contract Documents**

**A.** The Contract Documents may be amended to provide for additions, deletions and revisions in the Work or to modify the terms and conditions thereof in one or more of the following ways:

1. a Written Amendment or
2. a Change Order (pursuant to Article 10), whether pursuant to a Work Change Directive or otherwise.

**B.** The requirements of the Contract Documents may be supplemented and minor variations and deviations in the Work may be authorized, in one or more of the following ways

1. DESIGN PROFESSIONAL's approval of a Shop Drawing or Sample (pursuant to Paragraph 6.18), or
2. DESIGN PROFESSIONAL's written interpretation or clarification (pursuant to Paragraph 9.03).

### **3.05 Reuse of Documents**

**A.** CONTRACTOR and any Subcontractor or Supplier or other person or organization performing or furnishing any of the Work under this Contract:

1. shall not have or acquire any title to or ownership rights in any of the Drawings, Specifications or other documents (or copies of any thereof) prepared by or bearing the seal of DESIGN PROFESSIONAL or Consultant, and
2. shall not reuse any of such Drawings, Specifications, other documents or copies thereof on extensions of the Project or any other project without written consent of CITY, and of DESIGN PROFESSIONAL or Consultant, as applicable, and specific written verification or adaptation by DESIGN PROFESSIONAL or Consultant.

This prohibition will survive final payment, completion, and acceptance of the Work, or termination or completion of the Contract. Nothing herein shall preclude CONTRACTOR from retaining copies of the Contract Documents for record purposes.

## **ARTICLE 4 AVAILABILITY OF LANDS; SUBSURFACE AND PHYSICAL CONDITIONS; REFERENCE POINTS**

### **4.01 Availability of Lands**

**A.** CITY shall furnish the Site. CITY shall identify any encumbrances or restrictions not of general application but specifically related to use of lands so furnished with which CONTRACTOR will have to comply in performing the Work. Easements for permanent structures or permanent changes in existing facilities will be obtained and paid for by CITY, unless otherwise provided in the Contract Documents. If CONTRACTOR and CITY are unable to agree on entitlement to or the amount or extent of any adjustments in the Contract Price or the Contract Times or both as a result of any delay in CITY's furnishing these lands, rights-of-way or easements, CONTRACTOR may make a Claim as provided in Article 16. CONTRACTOR shall provide for all additional lands and access thereto that may be required for temporary construction facilities or storage of materials and equipment.

## 4.02 Subsurface and Physical Conditions

**A. Reports and Drawings:** Reference is made to the Supplementary Conditions for identification of:

1. Subsurface Conditions: Those reports of explorations and tests of subsurface conditions at or contiguous to the Site that have been utilized by DESIGN PROFESSIONAL in preparing the Contract Documents; and
2. Physical Conditions: Those drawings of physical conditions in or relating to existing surface or subsurface structures at or contiguous to the Site (except Underground Facilities) that have been utilized by DESIGN PROFESSIONAL in preparing the Contract Documents.

**B. Limited Reliance by CONTRACTOR on Technical Data Authorized:** CONTRACTOR may rely upon the general accuracy of the technical data contained in reports and drawings of subsurface or physical conditions, but such reports and drawings are not Contract Documents. The technical data is identified in the Supplementary Conditions. Except for reliance on such technical data, CONTRACTOR may not rely upon or make any Claim against CITY, DESIGN PROFESSIONAL or any Consultant with respect to:

1. the completeness of such reports and drawings for CONTRACTOR's purposes, including, but not limited to, any aspects of the means, methods, techniques, sequences and procedures of construction to be employed by CONTRACTOR and safety precautions and programs incident thereto; or
2. other data, interpretations, opinions and information contained in such reports or shown or indicated in such drawings, or
3. any CONTRACTOR interpretation of or conclusion drawn from any technical data or any such other data, interpretations, opinions or information.

## 4.03 Differing Subsurface or Physical Conditions

**A. Notice of Differing Subsurface or Physical Conditions.** If CONTRACTOR believes that any subsurface or physical condition at or contiguous to the Site that is uncovered or revealed either:

1. is of such a nature as to establish that any technical data on which CONTRACTOR is entitled to rely as provided in Paragraphs 4.02 A and 4.02 B is materially inaccurate; or
2. is of such a nature as to require a change in the Contract Documents; or
3. differs materially from that shown or indicated in the Contract Documents; or
4. is of an unusual nature, and differs materially from conditions ordinarily encountered and generally recognized as inherent in work of the character provided for in the Contract Documents; then CONTRACTOR shall, promptly after becoming aware thereof and before further disturbing the subsurface or physical conditions or performing any Work in connection therewith (except in an emergency as required by Paragraph 6.17), notify CITY and DESIGN PROFESSIONAL in writing about such condition(s). CONTRACTOR shall not further disturb such conditions or perform any Work in connection therewith (except as aforesaid) until receipt of written order to do so.

**B. DESIGN PROFESSIONAL's Review:** After receipt of notice as required by Paragraph 4.03 A, DESIGN PROFESSIONAL will promptly review the pertinent conditions, determine the necessity for CITY to obtain additional exploration or tests with respect thereto and notify CITY in writing (with a copy to CONTRACTOR) of DESIGN PROFESSIONAL's findings and conclusions.

**C. Possible Contract Documents Change:** If CITY concludes that a change in the Contract Documents is required as a result of a condition that meets one or more of the categories in Paragraph 4.03 A, a Work Change Directive or a Change Order will be issued as provided in Article 10 to reflect and document the consequences of such change.

**D. Possible Price or Times Adjustments:** An equitable adjustment in the Contract Price or in the Contract Times, or both, will be allowed to the extent that the existence of a subsurface or physical condition causes an increase or decrease in CONTRACTOR's cost of, or time required for, performance of the Work; subject, however, to the following:

1. the condition must meet any one or more of the categories described in Paragraphs 4.03 A.1 through 4.03 A.4, inclusive;
2. a change in the Contract Documents pursuant to Paragraph 4.03 C will not be an automatic authorization of, nor a condition precedent to, entitlement to any such adjustments;
3. with respect to Work that is paid for on a unit price basis, any adjustment in Contract Price will be subject to the provisions of Paragraphs 9.06 and 11.04; and
4. CONTRACTOR shall not be entitled to any adjustment in the Contract Price or Contract Times if;
  - a. CONTRACTOR knew, or by the exercise of ordinary care could have known, of such conditions at the time CONTRACTOR made a final commitment to CITY with respect to Contract Price and Contract Times by the submission of a Bid; or
  - b. the existence of such condition could reasonably have been discovered or revealed as a result of any examination, investigation, exploration, test or study of the Site and contiguous areas required by the Bidding Requirements or Contract Documents to be conducted by or for CONTRACTOR prior to CONTRACTOR's making such final commitment; or
  - c. CONTRACTOR failed to give the written notice as required by Paragraph 4.03 A.

**E.** If CITY and CONTRACTOR are unable to agree on entitlement to, or magnitude of, an equitable adjustment in the Contract Price pursuant to Article 11 and/or Contract Times pursuant to Article 12, a Claim may be made therefore as provided in Article 16. However, CITY, DESIGN PROFESSIONAL and Consultants shall not be liable to CONTRACTOR for any costs, losses or damages (including but not limited to all fees and charges of engineers, architects, attorneys, and other professionals and all other dispute resolution costs) sustained by CONTRACTOR on or in connection with any other project or anticipated project.

#### **4.04. Physical Conditions – Underground Facilities**

**A. Shown or Indicated:** The information and data shown or indicated in the Contract Documents with respect to existing Underground Facilities at or contiguous to the Site is based on information and data furnished to CITY or DESIGN PROFESSIONAL by the owners of such Underground Facilities or by others.

1. CITY and DESIGN PROFESSIONAL shall not be responsible for the accuracy or completeness of any such information or data; and
2. The cost of all of the following will be included in the Contract Price and CONTRACTOR shall have full responsibility for:
  - a. reviewing and checking all such information and data,
  - b. locating all Underground Facilities shown or indicated in the Contract Documents,
  - c. coordination of the Work with the owners of such Underground Facilities during construction, and
  - d. the safety and protection of all such Underground Facilities as provided in Paragraph 6.14 and repairing any damage thereto resulting from the Work.

**B. Not Shown or Indicated:** If an Underground Facility is uncovered or revealed at or contiguous to the Site, and was not shown or indicated in the Contract Documents, or was

shown or indicated incorrectly in the Contract Documents, CONTRACTOR shall, promptly after becoming aware thereof and before further disturbing conditions affected thereby or performing any Work in connection therewith (except in an emergency as required by Paragraph 6.17), identify the owner of such Underground Facility and give written notice to that owner and to CITY and DESIGN PROFESSIONAL.

**C. DESIGN PROFESSIONAL's Review:** After receipt of notice as required by Paragraph 4.04 B, DESIGN PROFESSIONAL will promptly review the consequences of the existence of the Underground Facility and notify CITY in writing (with a copy to CONTRACTOR) of DESIGN PROFESSIONAL's findings and conclusions.

**D. Possible Contract Documents Change:** If CITY concludes that a change in the Contract Documents is required as a result of the existence of an Underground Facility that either was not shown, or was shown incorrectly, in the Contract Documents, a Work Change Directive or Change Order will be issued as provided in Article 10 to reflect and document the consequences of such change.

**E. Possible Price or Times Adjustments:** An equitable adjustment in the Contract Price or in the Contract Times, or both, will be allowed to the extent that the existence of the Underground Facility causes an increase or decrease in CONTRACTOR's cost of, or time required for, performance of the Work; subject, however, to the following:

1. a change in the Contract documents pursuant to Paragraph 4.04 D will not be an automatic authorization of, nor a condition precedent to, entitlement to any such adjustments;
2. with respect to Work that is paid for on a unit price basis, any adjustment in Contract Price will be subject to the provisions of Paragraphs 9.06 and 11.04; and
3. CONTRACTOR shall not be entitled to any adjustment in the Contract Price or Contract Times if;
  - a. CONTRACTOR knew, or by the exercise of ordinary care could have known, of the existence of the Underground Facility at the time CONTRACTOR made a final commitment to CITY with respect to Contract Price and Contract Times by the submission of a Bid; or
  - b. the existence of the Underground Facility could reasonably have been discovered or revealed as a result of any examination, investigation, exploration, test or study of the Site and contiguous areas required by the Bidding Requirements or Contract Documents to be conducted by or for CONTRACTOR prior to CONTRACTOR's making such final commitment; or
  - c. CONTRACTOR failed to give the written notice as required by Paragraph 4.04 B.

**F.** If CITY and CONTRACTOR are unable to agree on entitlement to, or magnitude of, an equitable adjustment in the Contract Price pursuant to Article 11 and/or Contract Times pursuant Article 12, a Claim may be made therefore as provided in Article 16. However, CITY, DESIGN PROFESSIONAL and Consultants shall not be liable to CONTRACTOR for any costs, losses or damages (including but not limited to all fees and charges of engineers, architects, attorneys, and other professionals and all other dispute resolution costs) sustained by CONTRACTOR on or in connection with any other project or anticipated project.

#### **4.05 Reference Points**

**A.** CITY shall provide engineering surveys to establish reference points for construction that in DESIGN PROFESSIONAL's judgment are necessary to enable CONTRACTOR to proceed with the Work. CONTRACTOR shall be responsible for laying out the Work, shall protect and preserve the established reference points and property monuments, and shall make no changes or relocations without the prior written approval of CITY. CONTRACTOR shall report to DESIGN PROFESSIONAL whenever any reference point or property monument is lost or destroyed or requires relocation because of necessary changes in grades or locations, and shall be

responsible for the accurate replacement or relocation of such reference points or property monuments by professionally qualified personnel.

#### **4.06 Asbestos, Lead-Based Paint, PCBs, Petroleum, Hazardous Waste or Radioactive Material**

**A. Reports and Drawings:** Reference is made to the Supplementary Conditions for the identification of those reports and drawings relating to a Hazardous Environmental Condition identified at the Site, if any, that have been utilized by the DESIGN PROFESSIONAL in the preparation of the Contract Documents.

**B. Limited Reliance by CONTRACTOR on Technical Data Authorized:** CONTRACTOR may rely upon the general accuracy of the technical data contained in reports and drawings relating to a Hazardous Environmental Condition at the Site, but such reports and drawings are not Contract Documents. Such technical data is identified in the Supplementary Conditions. Except for such reliance on such technical data, CONTRACTOR may not rely upon or make any Claim against CITY, DESIGN PROFESSIONAL or any Consultant with respect to:

1. the completeness of such reports and drawings for CONTRACTOR's purposes, including, but not limited to, any aspects of the means, methods, techniques, sequences and procedures of construction to be employed by CONTRACTOR and safety precautions and programs incident thereto; or
2. other data, interpretations, opinions and information contained in such reports or shown or indicated in such drawings; or
3. any CONTRACTOR interpretation of or conclusion drawn from any technical data or any such other data, interpretations, opinions or information.

**C.** CONTRACTOR shall not be responsible for any Hazardous Environmental Condition uncovered or revealed at the Site which was not shown or indicated in Drawings or Specifications or identified in the Contract Documents to be within the scope of the Work. CONTRACTOR shall be responsible for all Hazardous Environmental Conditions created with any materials brought to the Site by CONTRACTOR, Subcontractors, Suppliers, or anyone else for whom CONTRACTOR is responsible. CONTRACTOR shall not be entitled to an extension of the Contract Times or an increase in the Contract Price if CONTRACTOR, Subcontractor, Supplier or anyone for whom CONTRACTOR is responsible created any Hazardous Environmental Condition at the Site or in connection with the Work.

**D.** If CONTRACTOR encounters a Hazardous Environmental Condition at the Site or if CONTRACTOR or anyone for whom CONTRACTOR is responsible creates a Hazardous Environmental Condition at the Site, CONTRACTOR shall immediately:

1. secure or otherwise isolate such condition;
2. stop all Work in connection with such condition and in any area affected thereby (except in an emergency as required by Paragraph 6. 15); and
3. notify CITY and DESIGN PROFESSIONAL (and promptly thereafter confirm such notice in writing). CITY shall promptly consult with DESIGN PROFESSIONAL concerning the necessity for CITY to retain a qualified expert to evaluate such condition or take corrective action, if any.

**E.** CONTRACTOR shall neither resume Work nor be required to resume Work in connection with such condition or in any affected area until after CITY has obtained any required permits related thereto and delivered to CONTRACTOR written notice:

1. specifying that such condition and any affected area is or has been rendered safe for the resumption of Work; or
2. specifying any special conditions under which such Work may be resumed safely. If CITY and CONTRACTOR cannot agree as to entitlement to or on the amount or extent, if any, of any adjustment in Contract Price pursuant to Article 11 and/or Contract Times to

pursuant to Article 12 as a result of such Work stoppage or such special conditions under which Work is agreed to be resumed by CONTRACTOR, a Claim may be made therefore as provided in Article 16.

F. If after receipt of written notice as required in Paragraph 4.06 E, CONTRACTOR does not agree to resume Work based on a reasonable belief it is unsafe, or does not agree to resume such Work under special conditions specified in the notice, then CITY may order the portion of the Work that is in the area affected by such condition to be deleted from the Work. If CITY and CONTRACTOR cannot agree as to entitlement to or magnitude of an equitable adjustment in Contract Price pursuant to Article 11 and/or Contract Times pursuant to Article 12 as a result of deleting such portion of the Work, then a Claim may be made therefore as provided in Article 16. CITY may have such deleted portion of the Work performed by CITY's own forces or others in accordance with Article 7.

G. The provisions of Paragraphs 4.02, 4.03, and 4.04 are not intended to apply to a Hazardous Environmental Condition uncovered or revealed at the Site.

H. All materials used, whether new or salvaged, shall be asbestos-free materials. CONTRACTOR shall immediately call to the attention of the CITY's Representative any specified material or product which the CONTRACTOR knows or suspects to contain asbestos, whether new or salvaged.

## **ARTICLE 5 BONDS AND INSURANCE**

### **5.01 Performance, Payment and Other Bonds**

A. CONTRACTOR shall furnish Performance and Maintenance and Payment Bonds, each in an amount at least equal to the Contract Price, as set out in the Contract Documents, as security for the faithful performance and payment of all CONTRACTOR's obligations under the Contract Documents. These Bonds shall remain in effect at least until one (1) year after the date when final payment of the Contract becomes due, except as provided otherwise by Laws or Regulations or by the Contract Documents. CONTRACTOR shall also furnish such other Bonds as are required by the Supplementary Conditions.

B. All Bonds shall be in the form prescribed by the Contract Documents except as provided otherwise by Laws or Regulations. A certified copy of the agent's authority to act must accompany all Bonds signed by an agent.

C. If the surety on any Bond furnished by CONTRACTOR is declared bankrupt or becomes insolvent, or its right to do business is terminated in any state where any part of the Project is located or it ceases to meet the requirement of Paragraph 5.01 B, CONTRACTOR shall within twenty (20) days thereafter substitute another Bond and surety, both of which must be acceptable to CITY.

### **5.02 Licensed Sureties and Insurers**

A. All Bonds and insurance required by the Contract Documents to be purchased and maintained by CITY or CONTRACTOR shall be obtained from surety or insurance companies that are duly licensed in the State of Missouri and in the jurisdiction in which the Project is located, if not in Missouri, to issue Bonds or insurance policies for the limits and coverages so required. All surety and insurance companies shall hold an A.M. Best rating of A-, V, or better.

### **5.03 Certificates of Insurance**

A. CONTRACTOR shall deliver to CITY and DESIGN PROFESSIONAL, prior to the start of any Work at the Project Site, properly completed certificates of insurance or other evidence that the required insurance is in full force and effect, in a form acceptable to CITY. The receipt or acceptance of a certificate of insurance that does not incorporate the required terms and coverage shall not constitute a waiver by the City of the insurance requirements contained in the Contract Documents.

**B.** All policies of insurance (and the certificates or other evidence thereof) required to be purchased and maintained by CONTRACTOR in accordance with Paragraphs 5.04 and 5.06 will contain waiver provisions in accordance with Paragraph 5.07 A. The certificates of insurance will contain a provision stating that should any of the policies described in the certificate be cancelled before the expiration date thereof, notice will be delivered in accordance with the policy provisions.

**C.** If the coverage afforded is cancelled or changed or its renewal is refused, CONTRACTOR shall give at least thirty (30) days prior written notice to CITY and to each other additional insured to whom a certificate of insurance has been issued.

#### **5.04 CONTRACTOR's Liability Insurance**

**A.** CONTRACTOR shall purchase and maintain such liability and other insurance as is appropriate for the Work being performed and furnished, and will provide protection from claims set forth below which may arise out of or result from CONTRACTOR's performance and furnishing of the Work and CONTRACTOR's other obligations under the Contract Documents, whether it is to be performed or furnished by CONTRACTOR, any Subcontractor or Supplier, or by anyone directly or indirectly employed by any of them to perform or furnish any of the Work, or by anyone for whose acts any of them may be liable:

1. claims under workers' compensation, disability benefits and other similar employee benefit acts;
2. claims for damages because of bodily injury, occupational sickness or disease, or death of CONTRACTOR's employees;
3. claims for damages because of bodily injury, sickness or disease, or death of any person other than CONTRACTOR's employees;
4. claims for damages insured by customary personal injury liability coverage;
5. claims for damages, other than to the Work itself, because of injury to or destruction of tangible property wherever located, including loss of use resulting therefore; and
6. claims for damages because of bodily injury or death of any person or property damage arising out of the ownership, maintenance or use of any motor vehicle.

**B.** The policies of insurance so required by Paragraph 5.04 A, to be purchased and maintained shall:

1. with respect to insurance required by Paragraphs 5.04 A.3 through 5.04 A.5 inclusive, include as additional insureds (subject to any customary exclusion for professional liability) CITY, DESIGN PROFESSIONAL, Consultants and any other individuals or entities identified in the Supplementary Conditions to be listed as additional insureds, and include coverage for the respective officers, directors, partners, employees, agents, and other consultants and subcontractors of each and any of all such additional insureds, and the insurance afforded to these additional insureds shall provide primary coverage for all claims covered thereby;
2. include at least the specific coverages and be written for not less than the limits of liability provided in Paragraph 5.04 C or required by Laws or Regulations, whichever is greater;
3. include completed operations insurance;
4. include contractual liability insurance covering CONTRACTOR's indemnity obligations;
5. remain in effect at least until final payment and at all times thereafter when CONTRACTOR may be correcting, removing or replacing defective Work in accordance with Paragraphs 13.06 and 13.07;

6. with respect to completed operations insurance, and any insurance coverage written on a claims-made basis, remain in effect for at least two (2) years after final payment (and CONTRACTOR shall furnish CITY and each other additional insured identified in the Supplementary Conditions to whom a certificate of insurance has been issued evidence satisfactory to CITY and any such additional insured of continuation of such insurance);

7. contain a cross-liability or severability of interest clause or endorsement. Insurance covering the specified additional insureds shall be primary insurance, and all other insurance carried by the additional insureds shall be excess insurance;

8. with respect to commercial automobile liability, commercial general liability, and umbrella liability insurance, CONTRACTOR shall require its insurance carrier(s) to waive all rights of subrogation against CITY, and CITY's officers, directors, partners, employees and agents; and

9. contain a provision or endorsement that the costs of providing the insureds a defense and appeal, including attorneys' fees, as insureds, shall be supplementary and shall not be included as part of the policy limits but shall remain the insurer's responsibility.

**C.** Specific policies of insurance required by this Paragraph 5.04 shall include:

1. Workers' Compensation and Employers' Liability Insurance. This insurance shall protect CONTRACTOR against all claims under applicable state workers' compensation laws, including coverage as necessary for the benefits provided under the United States Longshoremen's and Harbor Workers' Act and the Jones Act. CONTRACTOR shall also be protected against claims for injury, disease, or death of employees which, for any reason, may not fall within the provisions of workers' compensation laws. This policy shall include an "all states" or "other states" endorsement. The liability limits shall be not less than:

Workers' Compensation: Statutory

Employers' liability: \$1,000,000 each occurrence

2. Commercial Automobile Liability Insurance. This insurance shall be occurrence type written in comprehensive form and shall protect CONTRACTOR, and CITY, DESIGN PROFESSIONAL and Consultants against all claims for injuries to members of the public and damage to property of others arising from the use of motor vehicles, either on or off the Project Site, whether they are owned, non-owned, or hired.

The liability limits shall be not less than: \$2,000,000

3. Commercial General Liability Insurance. This insurance shall be occurrence type written in comprehensive form acceptable to CITY. This insurance shall protect CONTRACTOR, and CITY, DESIGN PROFESSIONAL and Consultants as additional insureds, against claims arising from injuries, sickness, disease, or death of any person or damage to property arising out of performance of the Work. The policy shall also include coverage for personal injury liability; contractual liability; completed operations and products liability; and for blasting, explosion, and collapse of buildings; and damage to underground property. The liability limits for bodily injury and property damage shall be not less than:

\$2,000,000 combined single limit for each occurrence

\$2,000,000 general aggregate.

4. The insurer's costs of providing the insureds a defense and appeal as additional insureds, including attorney's fees, shall be supplementary and shall not be included as part of the policy limits but shall remain the insurer's separate responsibility.

## **5.05 CITY's Liability Insurance**

**A.** In addition to the insurance required to be provided by CONTRACTOR under Paragraph 5.04, CITY, at CITY's option, may purchase and maintain at CITY's expense liability insurance



that will protect CITY against claims which may arise from operations under the Contract Documents.

## **5.06 Property Insurance**

**A.** Unless otherwise provided in the Supplementary Conditions, CONTRACTOR shall purchase and maintain property insurance on the Work at the Site in the amount of the full replacement cost thereof (subject to such deductible amounts as may be provided in the Supplementary Conditions or required by Laws or Regulations). This insurance shall:

1. include the interests of CITY, CONTRACTOR, Subcontractors, and any other persons or entities identified in the Supplementary Conditions, each of whom is deemed to have an insurable interest and shall be listed as an insured or additional insured;
2. be written on a Builder's Risk "all-risk" or open peril or special causes of loss policy form that shall at least include insurance for physical loss or damage to the Work, temporary buildings, falsework and materials and equipment in transit, and shall insure against at least the following perils or causes of loss: fire, lightning, extended coverage, theft, vandalism and malicious mischief, earthquake, tornado, collapse, debris removal, demolition occasioned by enforcement of Laws or Regulations, water damage, damage caused by frost and freezing, and acts of God;
3. be maintained in effect until final payment is made unless otherwise agreed to in writing by CITY with thirty (30) days written notice to each other additional insured to whom a certificate of insurance has been issued.

**B.** CITY shall not be responsible for purchasing and maintaining any property insurance to protect the interests of CONTRACTOR, Subcontractors or others involved in the Work to the extent of any deductible amounts. The risk of loss within the deductible amounts will be borne by CONTRACTOR, Subcontractor or others suffering any such loss and if any of them wishes property insurance coverage within the limits of such amounts, each may purchase and maintain it at the purchaser's own expense.

## **5.07 Waiver of Rights**

**A.** CITY and CONTRACTOR intend that all policies purchased in accordance with Paragraphs 5.04 and 5.06 will protect CITY, CONTRACTOR, DESIGN PROFESSIONAL Consultants, Subcontractors, and all other persons or entities identified in the Supplementary Conditions to be listed as insureds or additional insureds in such policies and will provide primary coverage for all losses and damages caused by the perils covered thereby. All such policies shall contain provisions to the effect that in the event of payment of any loss or damage the insurers will have no rights of recovery against any of the insureds or additional insureds thereunder. CITY and CONTRACTOR waive all rights against each other and their respective officers, directors, partners, employees and agents for all losses and damages caused by, arising out of or resulting from any of the perils covered by such policies and any other property insurance applicable to the Work, but only to the extent of insurance coverage; and, in addition, waive all such rights against DESIGN PROFESSIONAL, Consultants, Subcontractors, and all other persons or entities identified in the Supplementary Conditions to be listed as insureds or additional insureds (and the officers, directors, partners, employees, agents, and other consultants and subcontractors of any and each of them) under such policies for losses and damages so caused and covered by insurance. None of the above waivers shall extend to the rights that any party making such waiver may have to the proceeds of insurance held by CITY as trustee or otherwise payable under any policy so issued. None of the above waivers shall apply if specifically in conflict with Laws and Regulations.

## **5.08 Receipt and Application of Insurance Proceeds**

**A.** Any insured loss under the property insurance will be adjusted with CITY and made payable to CITY as fiduciary for the insureds, as their interests may appear, subject to the requirements of any indentures of indebtedness entered into by CITY.

**B.** CITY as fiduciary shall have power to adjust and settle any loss with the insurers unless one of the parties in interest shall object to CITY's exercise of this power in writing within fifteen (15) days after the occurrence of loss. If such objection is made, CITY as fiduciary shall make settlement with the insurers in accordance with such agreement as the parties in interest may reach. If no such agreement among the parties in interest is reached, CITY as fiduciary shall adjust and settle the loss with the insurers.

## **5.09 Partial Utilization – Property Insurance**

**A.** If CITY finds it necessary to occupy or use a portion or portions of the Work prior to Substantial Completion of all the Work, such use or occupancy may be accomplished in accordance with Paragraph 14.05; provided that no such use or occupancy shall commence before the insurers providing the property insurance have acknowledged notice thereof and in writing effected any changes in coverage necessitated thereby. The insurers providing the property insurance shall consent by endorsement on the policy or policies, but the property insurance shall not be canceled or permitted to lapse on account of any such partial use or occupancy.

# **ARTICLE 6 CONTRACTOR'S RESPONSIBILITIES**

## **6.01 Indemnification**

**A.** For purposes of this Paragraph 6.01 only, the following terms shall have the meanings listed:

1. Claims means all claims, damages, liability, losses, costs and expenses, including court costs and reasonable attorneys' fees, including attorney's fees incurred by the City in the enforcement of this indemnity obligation.

2. CONTRACTOR'S Agents means CONTRACTOR's officers, employees, sub-consultants, subcontractors, successors, assigns, invitees, and other agents.

3. CITY means CITY, its Program Manager/Construction Advisor and any of their agents, officials, officers, employees and program managers or construction advisors.

**B.** CONTRACTOR's obligations under this Paragraph with respect to indemnification for acts or omissions, including negligence, of CITY, shall be limited to the coverage and limits of insurance that CONTRACTOR is required to procure and maintain under this Contract. CONTRACTOR affirms that it has had the opportunity to recover the costs of the liability insurance required in this Contract in its contract price.

**C.** CONTRACTOR shall defend, indemnify and hold harmless CITY from and against all Claims arising out of or resulting from all acts or omissions in connection with this Contract caused in whole or in part by CONTRACTOR or CONTRACTOR's Agents, regardless of whether or not caused in part by any act or omission, including negligence, of OWNER.

**D.** In any and all Claims against CITY, DESIGN PROFESSIONAL, CONSULTANT, or any of their respective agents, officers, directors or employees by any employee (or the survivor or personal representative of such employee) of CONTRACTOR, any Subcontractor, any Supplier, any person or organization directly or indirectly employed by any of them to perform or furnish any of the Work, or anyone for whose acts any of them may be liable, the indemnification obligation under Paragraph 6.01 C shall not be limited in any way by any limitation on the amount or type of damages, compensation or benefits payable by or for CONTRACTOR or any such Subcontractor, Supplier or other person or organization under workers' compensation acts, disability benefit acts or other employee benefit acts.

E. The indemnification obligations of CONTRACTOR under Paragraph 6.01 C shall not extend to liability arising out of, resulting from, or caused by the professional negligence, errors or omissions of DESIGN PROFESSIONAL, CONSULTANT, or any of their respective agents, officers, directors or employees.

## **6.02 Supervision and Superintendence**

A. CONTRACTOR shall supervise, inspect and direct the Work competently and efficiently, devoting such attention thereto and applying such skills and expertise as may be necessary to perform the Work in accordance with the Contract Documents. CONTRACTOR shall be solely responsible for the means, methods, techniques, sequences and procedures of construction, but CONTRACTOR shall not be responsible for the negligence of others in the design or specification of a specific means, method, technique, sequence or procedure of construction which is shown or indicated in and expressly required by the Contract Documents. CONTRACTOR shall be responsible to see that the completed Work complies accurately with the Contract Documents.

B. At all times during the progress of the Work, CONTRACTOR shall assign a competent resident superintendent of the Work, who shall not be replaced without written request to and approval by CITY except under extraordinary circumstances. The superintendent will be CONTRACTOR's representative at the Site and shall have authority to act on behalf of CONTRACTOR. All communications given to or received from the superintendent shall be binding on CONTRACTOR.

C. If it is determined to be in the best interest of the Work, CONTRACTOR shall replace the project manager, resident superintendent or any other employee of the CONTRACTOR, Subcontractors, Suppliers or other persons or organizations performing or furnishing any of the Work on the project upon written request by the CITY.

## **6.03 Services, Working Hours, Labor, Materials and Equipment**

A. CONTRACTOR shall provide competent, suitably qualified personnel to survey, lay out and construct or perform the Work as required by the Contract Documents. CONTRACTOR shall at all times maintain good discipline and order at the Site. Except as otherwise required for the safety or protection of persons or the Work or property at the Site or adjacent thereto, and except as otherwise indicated in the Contract Documents, all Work at the Site shall be performed during regular working hours. CONTRACTOR shall not permit overtime work or the performance of Work on Saturday, Sunday or any legal holiday without CITY's written consent given after prior written notice to DESIGN PROFESSIONAL.

B. Unless otherwise specified in Division 1, General Requirements, CONTRACTOR shall furnish and assume full responsibility for all services, materials, equipment, labor, transportation, construction equipment and machinery, tools, appliances, fuel, power, light, heat, telephone, water, sanitary facilities, temporary facilities and all other facilities and incidentals necessary for the furnishing, performance, testing, start-up and completion of the Work.

C. All materials and equipment shall be of good quality and new, except as otherwise provided in the Contract Documents. All warranties and guarantees specifically called for by the Specifications shall expressly run to the benefit of CITY. If required by DESIGN PROFESSIONAL, CONTRACTOR shall furnish satisfactory evidence (including reports of required tests) as to the source, kind, and quality of materials and equipment. All materials and equipment shall be stored, applied, installed, connected, erected, used, cleaned and conditioned in accordance with instructions of the applicable Supplier, except as otherwise provided in the Contract Documents.

D. It is the policy of the CITY that any manufactured goods or commodities used or supplied in the performance of this Contract and any subcontract hereto shall be manufactured or produced in the United States whenever possible.

## **6.04 Progress Schedule**

**A.** CONTRACTOR shall adhere to the progress schedule established in accordance with Article 2 as it may be adjusted from time to time as provided below:

1. CONTRACTOR shall provide, at least once every thirty (30) calendar days, updated information on the project schedule, including thirty (30) day look ahead schedules, projected variances per event category and per Subcontractor, identification of all variances and calculation of the number of Days difference between the as-built critical path and the project schedule critical path

2. CONTRACTOR shall, with each application for payment, provide completed monthly updated status report for the previous month on the project schedule and updated information indicating as-built and as-planned conditions. The updated information on the project schedule shall not modify any Milestone dates in the project schedule that CITY has previously approved. The updated information required is a condition precedent to payment pursuant to paragraph 14.02 and shall include at a minimum:

- a. a concise statement of the outlook for meeting project schedule dates and the reasons for any change in outlook from the previous report;
- b. a review of any significant technical problems encountered during the month;
- c. an explanation of any corrective action taken or proposed; and
- d. a summary of any Claims anticipated by CONTRACTOR with respect to the Work, including the anticipated costs and schedule impacts of any such Claims.

## **6.05 Recovery Schedules**

**A.** If the CONTRACTOR should:

1. fail, refuse or neglect to supply a sufficient number of workers or to deliver the materials or equipment with such promptness as to prevent the delay in the progress of the Work;
2. fail in any respect to commence and diligently prosecute the Work in accordance with the approved baseline project schedule in order to achieve substantial completion;
3. fail to commence, prosecute, finish, deliver or install the different portions of the Work on time as specified in the approved baseline project schedule; or
4. fail in the performance of any of the material covenants of the Contract Documents;

CITY shall have the right to direct the CONTRACTOR, upon seven (7) calendar days notice, to prepare a written recovery plan, for CITY's approval, to accelerate the Work in order to conform to the approved baseline project schedule, including, without limitation, providing additional labor or expediting delivery of materials, performing overtime or re-sequencing the Work without adjustments to the Contract value. Upon CITY's approval of the recovery plan, CONTRACTOR shall accelerate the Work in accordance with the plan.

**B.** Proposed recovery schedules shall be submitted to the CITY as a separate project plan for review and approval by CITY prior to incorporation into the approved baseline schedule. The recovery schedule shall be submitted in a format compatible with the baseline schedule format. Each proposed revision shall be submitted as a separate schedule, with the following minimum requirements:

1. A critical path method diagram showing revised and affected activities or Milestones.
2. An activity report for all revised and affected activities or Milestones.

**C.** Upon acceptance of the recovery schedule by CITY, data shall be added or revised for all new or revised activities and incorporated into the approved baseline project schedule.

## 6.06 Substitutes and “Or-Equal” Items

**A. Materials or equipment:** Whenever an item of material or equipment is specified or described in the Contract Documents by using the name of a proprietary item or the name of a particular Supplier, the specification or description is intended to establish the type, function, appearance and quality required. Unless the specification or description contains, or is followed by, words reading that no like, equivalent or “or-equal” item or no substitution is permitted, other items of material or equipment or material or equipment of other Suppliers may be submitted to CITY for review by CITY’s Representative under the following circumstances:

1. “Or-Equal”: If, prior to receipt of Bids, Bidder proposes an item of material or equipment as functionally equal to that named and sufficiently similar so that no change in related Work will be required, CITY’s Representative may request DESIGN PROFESSIONAL to consider it as an “or-equal” item. DESIGN PROFESSIONAL will review and recommend the acceptance, or rejection, of the proposed item to the CITY’s Representative. For the purposes of this Paragraph, a proposed item of material or equipment will be considered functionally equal to an item so named if:

a. in the exercise of reasonable judgment DESIGN PROFESSIONAL determines that:

(1) it is at least equal in quality, durability, appearance, strength, and design characteristics; and

(2) it will reliably perform at least equally well the function imposed by the design concept of the completed Project as a functioning whole; and

b. Bidder certifies that:

(1) there is no increase in cost to the CITY; and

(2) it will conform substantially, even with deviations, to the detailed requirements of the item named in the Contract Documents.

If the CITY’s Representative approves the proposed item, it may be accepted by CITY.

2. Substitute Items: If CONTRACTOR proposes an item of material or equipment as a substitute item, then CONTRACTOR shall submit sufficient information as provided below to allow CITY’s Representative to determine that the item of material or equipment proposed is essentially equivalent to that named and an acceptable substitute therefore. The procedure for review by the CITY’s Representative will include the following as supplemented in the General Requirements and as CITY’s Representative may determine is appropriate under the circumstances:

a. Requests for review of proposed substitute items of material or equipment will not be accepted by CITY’s Representative from anyone other than CONTRACTOR.

b. If CONTRACTOR wishes to furnish or use a substitute item of material or equipment, CONTRACTOR shall first make written application to CITY’s Representative for acceptance thereof.

c. In the application, CONTRACTOR shall certify that the proposed substitute will perform adequately the functions and achieve the results called for by the general design, be similar in substance to that specified and be suited to the same use as that specified. The application will state the extent, if any, to which the evaluation and acceptance of the proposed substitute will impact CONTRACTOR’s achievement of Substantial Completion, whether or not acceptance of the substitute for use in the Work will require a change in any of the Contract Documents (or in the provisions of any other direct contract with CITY for work on the Project) to adapt the design to the proposed substitute and whether or not incorporation or use of the substitute in connection with the Work is subject to payment of any license fee or royalty.

d. All variations of the proposed substitute from that specified will be identified in the application and available maintenance, repair and replacement service will be indicated. The application will also contain an itemized estimate of all costs or credits that will result directly or indirectly from acceptance of such substitute, including costs of redesign and claims of other contractors affected by the resulting change, all of which will be considered by CITY's Representative in evaluating the proposed substitute. CITY's Representative may require CONTRACTOR to furnish additional data about the proposed substitute.

If the CITY's Representative approves the proposed item, CITY may accept it.

**B. Substitute Construction Methods or Procedures:** If a specific means, method, technique, sequence or procedure of construction is shown or indicated in and expressly required by the Contract Documents, CONTRACTOR may furnish or utilize a substitute means, method, technique, sequence or procedure of construction acceptable to DESIGN PROFESSIONAL. CONTRACTOR shall notify CITY and submit sufficient information to allow DESIGN PROFESSIONAL, in DESIGN PROFESSIONAL's sole discretion, to determine that the substitute proposed is equivalent to that expressly called for by the Contract Documents.

**C. Expenses:** Bidder shall provide all data in support of any "or equal" at Bidder's expense, and CONTRACTOR shall provide all data in support of any proposed substitute at CONTRACTOR's expense.

**D. Evaluation:** DESIGN PROFESSIONAL and CITY's Representative will be allowed a reasonable time within which to evaluate each proposal or submittal made pursuant to Paragraphs 6.06 A, and 6.06 B. CITY will be the sole judge of acceptability. No "or-equal" or substitute will be ordered, installed or utilized without CITY's prior written acceptance which will be evidenced by either a Change Order or an approved Shop Drawing. CITY may require CONTRACTOR to furnish at CONTRACTOR's expense, a special performance guarantee or other surety with respect to any "or-equal" substitute. DESIGN PROFESSIONAL will record time required by DESIGN PROFESSIONAL and Consultants in evaluating substitutes proposed or submitted by CONTRACTOR pursuant to Paragraphs 6.06 A and 6.06 B and in making changes in the Contract Documents (or in the provisions of any other direct contract with CITY for work on the Project) occasioned thereby. Whether or not CITY accepts a substitute so proposed or submitted by CONTRACTOR, CONTRACTOR shall reimburse CITY for the reasonable charges of DESIGN PROFESSIONAL and Consultants for evaluating each such proposed substitute.

## **6.07 Concerning Subcontractors, Suppliers and Others**

**A.** CONTRACTOR shall not employ or retain any Subcontractor, Supplier or other person or organization (including those acceptable to CITY as indicated in Paragraph 6.07 B), whether initially or as a substitute, against whom CITY has a reasonable objection, including but not limited to debarment by City or another governmental entity or decertification of the Subcontractor from the City's Minority and Women's Business Enterprise Program as a result of the Subcontractor's failure to comply with any of the requirements of the provisions of Chapter 3 of the City's Code as determined by the Director of the Civil Rights and Equal Opportunity Department. Contractor shall insert this provision in any subcontractor agreement associated with this Contract. CONTRACTOR shall not be required to employ any Subcontractor, Supplier or other person or organization to furnish or perform any of the Work against whom CONTRACTOR has reasonable objection. CONTRACTOR shall submit required information for all Subcontractors on Form 01290.09 - Subcontractor and Major Material Suppliers List, provided in these Contract Documents, prior to Subcontractor beginning Work at the Site.

**B.** The Supplementary Conditions require the identity of certain Subcontractors, Suppliers or other persons or organizations (including those who are to furnish the principal items of materials or equipment) to be submitted to CITY on or before the date specified in the Supplementary Conditions, for acceptance by CITY. If CONTRACTOR has submitted a list

thereof in accordance with the Supplementary Conditions, CITY may accept (either in writing or by failing to make written objection thereto by the date indicated for acceptance or objection in the Contract Documents) any such Subcontractor, Supplier or other person or organization so identified, or may reject same on the basis of reasonable objection after due investigation, in which case CONTRACTOR shall submit an acceptable replacement for the rejected Subcontractor, Supplier or other person or organization. The Contract Price will be adjusted by the difference in the cost occasioned by such substitution, and an appropriate Change Order will be issued or Written Amendment signed. No acceptance by CITY of any such Subcontractor, Supplier or other person or organization shall constitute a waiver of any right of CITY or DESIGN PROFESSIONAL to reject defective Work.

**C.** CONTRACTOR shall be fully responsible to CITY for all acts and omissions of the Subcontractors, Suppliers and other persons and organizations performing or furnishing any of the Work under a direct or indirect contract with CONTRACTOR just as CONTRACTOR is responsible for CONTRACTOR's own acts and omissions. Nothing in the Contract Documents shall create for the benefit of any such Subcontractor, Supplier or other person or organization any contractual relationship between CITY or DESIGN PROFESSIONAL and any such Subcontractor, Supplier or other person or organization, nor shall it create any obligation on the part of CITY or DESIGN PROFESSIONAL to pay or to see to the payment of any moneys due any such Subcontractor, Supplier or other person or organization except as may otherwise be required by Laws or Regulations.

**D.** CONTRACTOR shall be solely responsible for scheduling and coordinating the Work of Subcontractors, Suppliers and other persons and organizations performing or furnishing any of the Work under a direct or indirect contract with CONTRACTOR.

**E.** CONTRACTOR shall contractually require all Subcontractors, Suppliers and such other persons and organizations performing or furnishing any of the Work to communicate with CITY and DESIGN PROFESSIONAL through CONTRACTOR.

**F.** The divisions and sections of the Specifications and the identifications of any Drawings shall not control CONTRACTOR in dividing the Work among Subcontractors or Suppliers or delineating the Work to be performed by any specific trade.

**G.** All Work performed for CONTRACTOR by a Subcontractor or Supplier shall be pursuant to an appropriate written agreement between CONTRACTOR and the Subcontractor or Supplier that specifically binds the Subcontractor or Supplier to the applicable terms and conditions of the Contract Documents for the benefit of CITY. Whenever any such agreement is with a Subcontractor or Supplier who is listed as an additional insured on the property insurance provided in Paragraph 5.06, the agreement between the CONTRACTOR and the Subcontractor or Supplier will contain provisions whereby the Subcontractor or Supplier waives all rights against CITY, CONTRACTOR, DESIGN PROFESSIONAL, Consultants and all other additional insureds for all losses and damages caused by, arising out of or resulting from any perils, to the extent covered by such policies and any other property insurance applicable to the Work. If the insurers on any such policies require separate waiver forms to be signed by any Subcontractor or Supplier, CONTRACTOR will obtain the same.

**H.** Except as otherwise provided in this subsection H and in accordance with the provisions of subsection C hereof, the agreement between CONTRACTOR and the Subcontractor or Supplier referred to in subsection G, shall provide that the CONTRACTOR and the Subcontractor or Supplier agree not to request CITY or CITY's Representative to intervene in or facilitate the resolution of claims or contract disputes arising out of or related to the agreement between CONTRACTOR and the Subcontractor or Supplier. Furthermore, the Contracts between CONTRACTOR and Subcontractors or Suppliers shall provide that all unresolved claims and disputes between CONTRACTOR and the Subcontractor or Supplier that remain unresolved after thirty (30) calendar days from the notice of claim, shall be subject to mediation as a condition precedent to the institution of legal proceedings by either party. Any such mediation shall be conducted in accordance with the CITY's Code Section 3-467.

I. CONTRACTOR shall not insert any provision in any subcontractor agreement associated with this Contract that explicitly states or implies that the subcontractor shall only be paid for work performed if or when the general CONTRACTOR is paid by the CITY . Contractor's compliance with this provision is a material term of this Contract.

J. CONTRACTORS shall not deny any Subcontractor subcontracting opportunities solely because the Subcontractor is not a signatory to collective bargaining agreements with organized labor.

#### **6.08 Patent Fees and Royalties**

A. CONTRACTOR shall pay all license fees and royalties and assume all costs incident to the use in the performance of the Work or the incorporation into the Work of any invention, design, process, product or device which is the subject of patent rights or copyrights held by others. If a particular invention, design, process, product or device is specified in the Contract Documents for use in the performance of the Work, and if to the actual knowledge of CITY or DESIGN PROFESSIONAL its use is subject to patent rights or copyrights calling for the payment of any license fee or royalty to others, the existence of such rights shall be disclosed by CITY in the Contract Documents. To the fullest extent permitted by Laws or Regulations, CONTRACTOR shall defend, indemnify and hold harmless CITY, DESIGN PROFESSIONAL, Consultants and the officers, directors, employees, agents and other consultants of each and any of them from and against all claims, costs, losses and damages (including but not limited to all fees and charges of engineers, architects, attorneys, and other professionals and all court or arbitration or other dispute resolution costs) arising out of or resulting from any infringement of patent rights or copyrights incident to the use in the performance of the Work or resulting from the incorporation into the Work of any invention, design, process, product or device not specified in the Contract Documents.

#### **6.09 Permits**

A. Unless otherwise provided in the Supplementary Conditions, CONTRACTOR shall obtain and pay for all construction permits and licenses. CITY shall assist CONTRACTOR, when necessary, in obtaining such permits and licenses. CONTRACTOR shall pay all governmental charges and inspection fees necessary for the prosecution of the Work, which are applicable at the time of opening of Bids, or, if there are no Bids, on the Effective Date of the Contract. CONTRACTOR shall pay all charges of utility owners for connections to the Work.

B. CONTRACTOR, at its own expense, shall comply with all Federal, State and local laws and regulations, including, but not limited to the Missouri Clean Water Law (Chapter 644 RSMo) together with any accompanying regulation(s) contained in the Missouri Code of State Regulations (CSR Title 10), as well as any implementing permits, together with any CITY Provisions during the life of this Contract including but not limited to:

1. Approvals and permits as required for construction or land disturbance activities.
2. Compliance with the State of Missouri – Department of Natural Resources (“MDNR”) Missouri State Operating Permit (“Land Disturbance Permit”), MO-R100006 for all construction or land disturbance activity.
3. Development and implementation of a Storm Water Pollution Prevention Plan (SWPPP).
  - (a) Contractor shall not commence land disturbance activity until the initial SWPPP has been finalized.
  - (b) Preparation and submittal of all applications, documentation and exhibits required to obtain MDNR approvals for uninterrupted Work at the Site.
  - (c) Amending/Updating SWPPP.
  - (d) Site Inspections and submittal of Inspection Reports



(e) Proper Operation and Maintenance to achieve compliance with the terms of the Permit.

(f) Maintenance of required records in accordance with MDNR requirements and requirements included in Article 6 of these Contract Documents.

4. In addition to requirements of Article 6, Contractor shall also provide record access to Missouri Department of Natural Resources (MDNR).

5. Failure to control erosion and water pollution is a permit violation. CONTRACTOR shall have 24 hours after receiving notice of the violation to correct the problem. If the CONTRACTOR fails to correct the problem after the time prescribed, the City will hire a remediation expert to fix the problem. In such an event, the CONTRACTOR shall be liable to the City for the remediation costs plus a 10% mark-up of the total contract price. If the CONTRACTOR receives three (3) notices of violation of the erosion control plan and the City's MS4 permit, the Director may issue a stop work order and delay any payment until control measures are properly functioning and stream damage has been mitigated. In such an event, any delay to the project schedule will result in liquidated damages assessed against the CONTRACTOR.

## **6.10 Compliance with Laws and Regulations**

**A.** CONTRACTOR shall comply with all federal, state and local laws, ordinances and regulations applicable to the work and this Contract. CONTRACTOR shall give all notices and comply with all Laws or Regulations applicable to furnishing and performing the Work. Except where otherwise expressly required by applicable Laws or Regulations, neither CITY nor DESIGN PROFESSIONAL shall be responsible for monitoring CONTRACTOR's compliance with any Laws or Regulations. The Laws or Regulations included in this Paragraph shall include, but not be limited to, those set forth in the Supplementary Conditions.

**B. Failure to Comply.** If CONTRACTOR performs any Work in violation of applicable Laws or Regulations, CONTRACTOR shall bear all claims, costs, losses and damages (including but not limited to all fees and charges of engineers, architects, attorneys, and other professionals and all court or arbitration or other dispute resolution costs) caused by, arising out of or resulting therefrom; however, it shall not be CONTRACTOR's primary responsibility to make certain that the Specifications and Drawings are in accordance with Laws or Regulations, but this shall not relieve CONTRACTOR of CONTRACTOR's obligations under Paragraph 3.03.

**C. Conflicts of Interest.** The provisions of City's Code Sections 2-2001 and 3-301, prohibiting City officers and employees from having a financial or personal interest in any contract with City, and Code Sections 3-307, and 3-309, imposing sanctions for violations, shall apply to this Contract. CONTRACTOR certifies that no officer or employee of City has, or will have, a direct or indirect financial or personal interest in this Contract, and that no officer or employee of City, or member of such officer's or employee's immediate family, either has negotiated, or has or will have an arrangement concerning employment to perform services on behalf of CONTRACTOR on this Contract.

**D. Licenses and Permits.** CONTRACTOR, at its own expense, shall secure or cause to be secured all licenses and permits from public or private sources necessary for the fulfillment of its obligations under this Contract. All references in this Contract to the "Code" shall mean City's Code of Ordinances, including any amendments thereto or re-codification thereof unless the context clearly indicates otherwise. CONTRACTOR shall obtain copies of all necessary licenses and permits from Subcontractors required for the Work before Subcontractors begin Work at the Site. CONTRACTOR shall retain such evidence in its files and make available to CITY within ten (10) days after CITY's written request.

**E. Americans with Disabilities Act.** CONTRACTOR agrees to comply, during the course of this Contract, with all provisions of Title II of the 2010 ADA Standards for Accessible Design as amended from time to time.

**F. Affirmative Action.** If the Contract Price exceeds \$300,000.00 and CONTRACTOR employs fifty (50) or more people, CONTRACTOR shall comply with City's Affirmative Action requirements in accordance with the provisions of Chapter 3 of City's Code, the rules and regulations relating to those sections, and any additions or amendments thereto. CONTRACTOR shall not discriminate against any employee or applicant for employment because of race, color, sex, religion, national origin or ancestry, disability, sexual orientation, gender identity or age in a manner prohibited by Chapter 3 of City's Code.

CONTRACTOR shall:

1. Submit, in print or electronic format, a copy of CONTRACTOR'S current certificate of compliance to the City's Civil Rights and Equal Opportunity Department (CREO) prior to receiving the first payment under the contract, unless a copy has already been submitted to CREO at any point within the previous two calendar years. If, and only if, CONTRACTOR does not possess a current certification of compliance, CONTRACTOR shall submit, in print or electronic format, a copy of its affirmative action program to CREO prior to receiving the first payment under the contract, unless a copy has already been submitted to CREO at any point within the previous two calendar years.

2. Require any Subcontractor awarded a subcontract exceeding \$300,000.00 to affirm that Subcontractor has an affirmative action program in place and will maintain the affirmative action program in place for the duration of the subcontract.

3. Obtain from any Subcontractor awarded a subcontract exceeding \$300,000.00 a copy of the Subcontractor's current certificate of compliance and tender a copy of the same, in print or electronic format, to CREO within thirty (30) days from the date the subcontract is executed. If, and only if, Subcontractor does not possess a current certificate of compliance, CONTRACTOR shall obtain a copy of the Subcontractor's affirmative action program and tender a copy of the same, in print or electronic format, to CREO within thirty (30) days from the date the subcontract is executed.

City has the right to take action as directed by City's Civil Rights and Equal Opportunity Department to enforce this provision. If CONTRACTOR fails, refuses or neglects to comply with the provisions of Chapter 3 of City's Code, then such failure shall be deemed a total breach of this Contract and this Contract may be terminated, canceled or suspended, in whole or in part, and CONTRACTOR may be declared ineligible for any further contracts funded by City for a period of one (1) year. This is a material term of this Contract.

**G. Minority and Women Business Enterprises and Workforce.** City is committed to ensuring that minorities and women participate to the maximum extent possible in the performance of City's construction contracts. If minority and women business enterprise (M/WBE) goals have been set for this Contract, CONTRACTOR agrees to comply with all requirements of City's Minority and Women's Business Enterprise Program as enacted in City's Code, Sections 3-421 through 3-469 and as hereinafter amended. CONTRACTOR shall meet or exceed both the MBE and WBE goals set forth in its Contractor Utilization Plan/Request for Waiver. If workforce utilization goals are applicable to this Contract, CONTRACTOR agrees to comply with all requirements of City's Construction Employment Program as enacted in City's Code, Sections 3-501 through 3-527 and as hereinafter amended. CONTRACTOR shall meet or exceed the construction employment goals unless the same shall have been waived in the manner provided by law. CONTRACTOR's compliance with this provision is a material part of this Contract.

#### **H. Records.**

1. For purposes of this section:

(a) "City" shall mean the City Auditor, the City's Internal Auditor, the City's Director of Civil Rights and Equal Opportunity, the City Manager, the City department administering this Contract and their delegates and agents.

(b) "Record" shall mean any document, book, paper, photograph, map, sound recordings or other material, regardless of physical form or characteristics, made or received in connection with this Contract and all Contract amendments and renewals.

2. CONTRACTOR shall maintain and retain all Records for a term of five (5) years that shall begin after the expiration or termination of this Contract and all Contract amendments. City shall have a right to examine or audit all Records and CONTRACTOR shall provide access to City of all records upon ten (10) days written notice from the City.

#### **I. Prevailing Wage.**

1. CONTRACTOR shall comply and require its Subcontractors to comply with;

a. sections 290.210 to 290.340, RSMO the State of Missouri Prevailing Wage Law (the "Law"); and

b. 8 CSR 30-3.010 to 8 CSR 30-3.060, the Prevailing Wage Law Rules (the "Rules"); and

c. the Annual Wage Order (Wage Order) issued by the State of Missouri's Department of Labor and Industrial Relations; and

d. any applicable Annual Incremental Wage Increase (Wage Increase) to the Annual Wage Order.

2. The Law, Rules, Annual Wage Order and any Wage Increase are incorporated into and made part hereof this Contract and shall be collectively referred to in this Section as the "Prevailing Wage Requirements."

3. CONTRACTOR shall pay and require its Subcontractors to pay to all workers performing work under this Contract not less than the prevailing hourly rate of wages for the class or type of work performed by the worker in accordance with the Law, Rules, Wage Order and any applicable Wage Increase. CONTRACTOR shall take whatever steps are necessary to insure that the prevailing hourly wage rates are paid and that all workers for CONTRACTOR and each of its Subcontractors are paid for the class or type of work performed by the worker in accordance with the Prevailing Wage Requirements. If CONTRACTOR shall fail to start to perform CONTRACTOR's obligations under the Contract Documents within sixty (60) days from the Effective Date of the Contract, CONTRACTOR and each of its subcontractors shall be obligated to pay all workers in accordance with any new Wage Order, as subsequently amended by any applicable Wage Increase, issued by the Department of Labor and Industrial Relations within the aforementioned sixty (60) day period. The new Wage Order and any applicable Wage Increase shall govern notwithstanding the fact that the Wage Order being replaced might be physically attached or incorporated in the Contract Documents.

4. Prior to each of its Subcontractors beginning Work on the Site, CONTRACTOR shall require each Subcontractor to complete CITY's Form 00490 entitled "Pre-contract Certification" that sets forth the Subcontractor's prevailing wage and tax compliance history for the two (2) years prior to the bid. CONTRACTOR shall retain one (1) year and make the Pre-contract Certifications available to CITY within five (5) days after written request.

5. CONTRACTOR shall:

a. Keep and require each of its Subcontractors engaged in the construction of public works in performance of the Contract to keep full and accurate records on City's "Daily Labor Force Report" Form indicating the worker's name, occupational title or classification group & skill and the workers' hours. City shall furnish blank copies of the Daily Labor Force Report Form to Contractor for its use and for distribution to Subcontractors. Contractor shall submit its and its Subcontractors Daily Labor Force Reports to City each day; and

b. Submit, and require each of its Subcontractors engaged in the construction of public works in performance of the Contract to submit electronically, in a format prescribed by the City, Certified Payroll Report Information indicating the worker's name, address, social security number, occupation(s), craft(s) of every worker employed in connection with the public work together with the number of hours worked by each worker and the actual wages paid in connection with the Project and other pertinent information as requested by the City; and

c. Submit, and require each of its Subcontractors engaged in the construction of public works in performance of the Contract to submit, electronically, in format prescribed by the City, a Payroll Certification. The Payroll Certification must be signed by the employee or agent who pays or supervises the payment of the workers employed under the Contract for the Contractor and each Subcontractor; and

d. The Daily Labor Force Report, documents used to compile information for the Certified Payroll Report, and Payroll Certification are collectively referred to in this Section as the "Records."

6. CONTRACTOR shall submit its and its Subcontractors Daily Labor Force Reports to CITY each day. CONTRACTOR shall make all of CONTRACTOR's and Subcontractors' Records open to inspection by any authorized representatives of OWNER and the Missouri Department of Labor and Industrial Relations at any reasonable time and as often as they may be necessary and such Records shall not be destroyed or removed from the State of Missouri for a period of one (1) year following the completion of the public work in connection with which the Records are made. CONTRACTOR shall have its and its Subcontractors Certified Payroll Reports and Payroll Certifications available at the CONTRACTOR's office and shall provide the Records to the City electronically at City's sole discretion. In addition, all Records shall be considered a public record and CONTRACTOR shall provide the Records to the CITY in the format required by the CITY within three (3) working days of any request by CITY at the CONTRACTOR's cost. CITY, in its sole discretion, may require CONTRACTOR to send any of the Records directly to the person who requested the Record at CONTRACTOR's expense.

7. CONTRACTOR shall post and keep posted a clearly legible statement of all prevailing hourly wage rates to be paid to all workers employed by CONTRACTOR and each of its Subcontractors in the performance of this Contract in a prominent and easily accessible place at the Site of the Work by all workers.

8. If the Contract Price exceeds \$250,000.00, CONTRACTOR shall and shall require each Subcontractor engaged in any construction of public works to have its name, acceptable abbreviation or recognizable logo and the name of the city and state of the mailing address of the principal office of the company, on each motor vehicle and motorized self-propelled piece of equipment which is used in connection with the Project during the time the CONTRACTOR or Subcontractor is engaged on the project. The sign shall be legible from a distance of twenty (20') feet, but the size of the lettering need not be larger than two (2") inches. In cases where equipment is leased or where affixing a legible sign to the equipment is impractical, the CONTRACTOR may place a temporary stationary sign, with the information required pursuant to this section, at the main entrance of the Project in place of affixing the required information on the equipment so long as such sign is not in violation of any state or federal statute, rule or regulation. Motor vehicles which are required to have similar information affixed thereto pursuant to requirements of a regulatory agency of the state or federal government are exempt from the provisions of this subsection.

9. CONTRACTOR must correct any errors in CONTRACTOR's or any Subcontractors' Records, or CONTRACTOR's or any Subcontractors' violations of the Law, Rules, Annual Wage Order and any Wage Increase within fourteen (14) calendar days after notice from CITY.

10. CONTRACTOR shall and shall require its Subcontractors to cooperate with the CITY and the Department of Labor and Industrial Relations in the enforcement of this Section, the Law, Rules, Annual Wage Order and any Wage Increase. Contractor shall and shall require its Subcontractors to permit CITY and the Department of Labor and Industrial Relations to interview any and all workers during working hours on the Project at CONTRACTOR's sole cost and expense.

11. CONTRACTOR shall file with CITY, upon completion of the Project and prior to final payment therefore, affidavits from CONTRACTOR and each of its Subcontractors, stating that each has fully complied with the provisions and requirements of the Missouri Prevailing Wage Law. CITY shall not make final payment until the affidavits, in proper form and order, from CONTRACTOR and each of its Subcontractors, are filed by CONTRACTOR.

12. CONTRACTOR shall forfeit as a statutory penalty to the CITY one hundred dollars (\$100.00) for each worker employed, for each calendar day, or portion thereof, such worker is paid less than the prevailing hourly rates for any work done under this Contract, by CONTRACTOR or by any of CONTRACTOR's Subcontractors. If CONTRACTOR or any of its Subcontractors have violated any section(s) of 290.210 to 290.340, RSMo, in the course of the execution of the Contract, CITY shall when making payments to the CONTRACTOR becoming due under this Contract, withhold and retain therefrom all sums and amounts due and owing as a result of any violation of sections 290.210 to 290.340, RSMo.

**J. Prevailing Wage Damages.** CONTRACTOR acknowledges and agrees that, based on the experience of CITY, violations of the Missouri Prevailing Wage Act, whether by CONTRACTOR or its Subcontractors, commonly result in additional costs to CITY. CONTRACTOR agrees that additional costs to CITY for any particular violation are difficult to establish and include but are not limited to: costs of construction delays, additional work for CITY, additional interest expenses, investigations, and the cost of establishing and maintaining a special division working under the City Manager to monitor prevailing wage compliance.

1. In the event of the failure by CONTRACTOR or any of its Subcontractors to pay wages as provided in the Missouri Prevailing Wage Act, CITY shall be entitled to deduct from the Contract Price, and shall retain as liquidated damages, one hundred dollars (\$100.00) per day, per worker who is paid less than the prevailing hourly rate of wages, to approximate the additional costs. The sum shall be deducted, paid or owed whether or not the Contract Times have expired.

2. CITY shall give written notice to CONTRACTOR setting forth the workers, who have been underpaid, the amount of the statutory penalty and the amount of the liquidated damages as provided for in this Subparagraph J. CONTRACTOR shall have fourteen (14) calendar days to respond, which time may be extended by CITY upon written request. If CONTRACTOR fails to respond within the specified time, the CITY's original notice shall be deemed final. If CONTRACTOR responds to CITY's notice, CITY will furnish CONTRACTOR a final decision in writing within five (5) days of completing any investigation.

**K. Missouri Secretary of State Business Entity Registration.** CONTRACTOR shall obtain from all Subcontractors for the Project, a copy of their current certificate of good standing or fictitious name registration from the Missouri Secretary of State before they begin work on the Site. CONTRACTOR shall retain such documents in its files and make available to CITY within ten (10) days after written request.

**L. Tropical Hardwoods.** The provisions of Code Section 2-1872, restricting the use of tropical hardwoods, shall apply to this Contract.

**M. Preference for Missouri Products.** Pursuant to Section 71.140 RSMo., preference shall be given to materials, products, supplies and all other articles produced, manufactured, made or grown within the State of Missouri.

**N. Guidelines for Open Excavations.**

1. CONTRACTOR shall restore required excavations to the level of the adjacent surfaces as soon as practicable. Unsupervised open excavations on public properties are discouraged at all times. If CONTRACTOR, in performance of the Work, makes or causes to be made any excavation in, upon, under, through or adjoining any street, sidewalk, alley, park, boulevard, parkway or any other public properties, and shall leave any part or portion thereof open, CONTRACTOR shall provide effective protection to the public.

2. CONTRACTOR shall protect and secure all excavations in roadways in compliance with existing federal, state and local codes and standards, including, but not limited to the most current edition of the Manual of Uniform Traffic Control Devices. CONTRACTOR shall protect and secure all unsupervised excavations not within roadways, either by covering or fencing.

a. Covering. A protective cover that can sustain the weight of persons or of objects that are placed upon it may be installed over an unsupervised excavation. The cover shall be secured to the ground to prevent movement. Protective covers shall have no opening(s) or protuberance(s) of sufficient size to cause a fall and/or injury. Advance warning devices shall be installed as necessary.

b. Fencing. Fencing to prevent entry may be installed surrounding an unsupervised excavation not protectively covered in its entirety. The fencing shall be a minimum of 42" in height. The fencing shall be constructed in such a manner that it is adequately secured and will remain upright at all times under normal Site conditions. All protective coverings and fences over and around excavations shall be inspected at least daily to assure integrity. Protective coverings and/or fences in heavily trafficked areas shall be inspected more often as necessary.

**O. Notification of Utilities.** CONTRACTOR shall adhere to the provisions of Sections 319.010 et seq., RSMo., which requires that a person or firm making an excavation in any public street, road or alley, right of way dedicated to public use, utility easement of record, or within any private street or private property do so only after giving notice to, and obtaining information from, owners of Underground Facilities. The 24-hour, toll-free accident prevention hotline number in Missouri is 1-800-344-7483 (1-800-Digrite).

**P. Employee Eligibility Verification.** CONTRACTOR shall adhere to the provisions of Sections 285.525 et seq., RSMo., which requires that for any contract exceeding five thousand dollars (\$5,000.00), CONTRACTOR shall execute and submit an affidavit, in a form prescribed by CITY, affirming that CONTRACTOR does not knowingly employ any person in connection with the contracted services who does not have the legal right or authorization under federal law to work in the United States as defined in 8 U.S.C. § 1324a(h)(3). CONTRACTOR shall attach to the affidavit documentation sufficient to establish CONTRACTOR'S enrollment and participation in an electronic verification of work program operated by the United States Department of Homeland Security (E-Verify) or an equivalent federal work authorization program operated by the United States Department of Homeland Security to verify information of newly hired employees, under the Immigration Reform and Control Act of 1986. CONTRACTOR may obtain additional information about E-Verify and enroll at <https://e-verify.uscis.gov/enroll/StartPage.aspx?JS=YES>. For those Contractors enrolled in E-Verify, the first and last pages of the E-Verify Memorandum of Understanding that CONTRACTOR will obtain upon successfully enrolling in the program shall constitute sufficient documentation for purposes of complying with this Section. CONTRACTOR shall submit the affidavit and attachments to CITY prior to execution of the Contract, or at any point during the term of the Contract if requested by City.

**Q. OSHA 10-Hour Training Requirement.** CONTRACTOR and any subcontractor working under this Contract shall require every employee on the Site to complete a ten-hour construction safety program which meets the requirements of Section 292.675, RSMo, except for those employees who shall have previously completed the required program and hold documentation to that effect. CONTRACTOR shall remove or require the removal of any

person from the Site who is subject to this requirement and who does not complete or is unable to produce documentation of their successful completion of the required program within the time limitations prescribed by Section 292.675, RSMo. CONTRACTOR shall forfeit the sum of two thousand five hundred dollars (\$2,500.00), in addition to one hundred dollars (\$100.00) per employee each calendar day, or portion thereof, the employee(s) shall continue to be employed without having completed the required program within the time limitations prescribed by Section 292.675, RSMo. CITY shall be entitled to withhold and retain any amounts due and owing hereunder when making payment to CONTRACTOR.

**R. Clean Air Act and Clean Water Act.** CONTRACTOR shall comply with requirements of the Clean Air Act (42 U.S.C. 7401 *et seq.*); Clean Water Act (33 U.S.C. 1251 *et seq.*), Missouri Clean Water Law (Chapter 644 RSMo), Code of Federal regulations (Title 40: Protection of Environment, Title 33: Navigation and Navigable Waters) and the rules of the Missouri Code of State Regulations (CSR Title 10).

**S. Contract information Management System.** If applicable, CONTRACTOR shall comply with CITY's Contract Information Management System requirements. CONTRACTOR shall use CITY's Internet web based Contract Information Management System/Project Management Communications Tool provided by CITY and protocols included in that software during the term of this Contract. CONTRACTOR shall maintain user applications to CITY's provided system for all personnel, subcontractors or suppliers as applicable and shall require subcontractors/subconsultants to maintain same.

**T. Anti-Discrimination Against Israel.** If this Contract exceeds \$100,000.00 and CONTRACTOR employs at least ten employees, pursuant to Section 34.600, RSMo., by executing this Contract, CONTRACTOR certifies it is not currently engaged in and shall not, for the duration of this contract, engage in a boycott of goods or services from the State of Israel; companies doing business in or with Israel or authorized by, licensed by, or organized under the laws of the State of Israel; or persons or entities doing business in the State of Israel.

**U. Ban the Box in Hiring and Promotion**

- a. Pursuant to Section 38-104, City Code Ordinances, CONTRACTOR shall not base a hiring or promotional decision on an applicant's criminal history or sentence related thereto, unless the employer can demonstrate that the employment-related decision was based on all information available including consideration of the frequency, recency and severity of a criminal record and that the record was reasonably related to the duties and responsibilities of the position.
- b. Notwithstanding subsection (a), CONTRACTOR may inquire about an applicant's criminal history after it has been determined that the individual is otherwise qualified for the position, and only after the applicant has been interviewed for the position. Any such inquiry may be made of all applicants who are within the final selection pool of candidates from which a job will be filled.
- c. This provision shall not apply to positions where employers are required to exclude applicants with certain criminal convictions from employment due to local, state or federal law or regulation.

**V. Title VI of the Civil Rights Act of 1964**

- a. Title VI of the Civil Rights Act of 1964 requires that no person in the United States shall, on the grounds of race, color, or national or origin (including limited English proficient individuals), be excluded from participation in, be denied the benefits of, or be subjected to discrimination under any program or activity receiving federal financial assistance. The City of Kansas City, Missouri requires compliance with the requirements of Title VI in all of its programs and activities regardless of the funding source.

- b. CONTRACTOR shall not discriminate on the grounds of race, color, or national or origin (including limited English proficient individuals).

#### **W. Non-discrimination in Employment**

CONTRACTOR shall not discriminate against any employee or candidate for employment on the basis of an individual's race, hair texture or hair style associated with an individual's race, color, sex, religion, national origin, or ancestry, disability, sexual orientation, gender identity or age in a manner prohibited by Chapter 38 of the City Code. CONTRACTOR shall not engage in any discrimination as prohibited by Chapter 3 of the City Code.

#### **X. Quality Services Assurance Act**

If this Contract exceeds \$160,000.00, CONTRACTOR certifies that CONTRACTOR will pay all employees who will work on this Contract in the city limits of Kansas City, Missouri at least \$15.00 per hour in compliance with the City's Quality Services Assurance Act, Section 3-66, Code of Ordinances unless City has granted CONTRACTOR an exemption pursuant to the Quality Services Assurance Act.

### **6.11 Taxes**

**A.** CONTRACTOR shall pay all sales, consumer, use and other similar taxes required to be paid by CONTRACTOR in accordance with the Laws or Regulations of the place of the Project which are applicable during the performance of the Work.

#### **B. Tax Compliance.**

1. As a condition precedent to CITY making its first payment to CONTRACTOR under this Contract, CONTRACTOR shall furnish to CITY sufficient proof from City's Commissioner of Revenue, dated not more than one (1) year prior to the date provided to CITY, verifying that CONTRACTOR is in compliance with the license and tax ordinances administered by City's Revenue Division of the Finance Department.

2. As a condition precedent to Subcontractors performing any Work under this Contract, CONTRACTOR shall obtain from Subcontractor sufficient proof from City's Commissioner of Revenue, dated not more than one (1) year before the date Subcontractor begins Work, verifying that the Subcontractor is in compliance with the license and tax ordinances administered by City's Revenue Division of the Finance Department. CONTRACTOR shall retain such documentation in its files and make available to CITY within ten (10) days after a written request.

3. As a condition precedent to CITY making final payment under this Contract, if this Contract is longer than one (1) year and exceeds the dollar threshold established by ordinance and included in the Supplementary Conditions, CONTRACTOR shall furnish to CITY sufficient proof from City's Commissioner of Revenue, dated not more than one (1) year before the filing of a final Application for Payment, verifying that CONTRACTOR is in compliance with the license and tax ordinances administered by City's Revenue Division of the Finance Department.

4. If this Contract is longer than one (1) year and exceeds the dollar threshold established by ordinance and included in the Supplementary Conditions, CONTRACTOR shall obtain from Subcontractors sufficient proof from City's Commissioner of Revenue, dated not more than one (1) year before the date of CONTRACTOR's final payment to the Subcontractor, that the Subcontractor was or is in compliance with the license and tax ordinances administered by City's Revenue Division of the Finance Department. CONTRACTOR shall retain such documentation in its files and make available to CITY within ten (10) days after written request.



5. If, at the time of final payment to CONTRACTOR, CONTRACTOR is unable to obtain from all its Subcontractors, if any, and furnish to CITY sufficient proof from City's Commissioner of Revenue that all its Subcontractors are in compliance with the license and tax ordinances administered by City's Revenue Division of the Finance Department, CITY may approve final payment to CONTRACTOR if CITY determines that CONTRACTOR has made a good faith effort to furnish evidence or that there are other extenuating circumstances which make it impossible for CONTRACTOR to furnish sufficient proof.

**C. Missouri Sales Tax Exemption.** Pursuant to Section 144.062, RSMo, CITY is a Missouri exempt entity and tangible personal property to be incorporated or consumed in the construction of this Project may be purchased without sales tax. CITY shall furnish CONTRACTOR a Missouri Project Exemption Certificate for Sales Tax at the time of issuance of the Notice to Proceed.

## **6.12 Use of Site and Other Areas**

**A.** CONTRACTOR shall confine construction equipment, the storage of materials and equipment, and the operations of workers to the Site and other areas identified in and permitted by the Contract Documents and other areas permitted by Laws or Regulations. CONTRACTOR shall not unreasonably encumber the Site and the other areas with construction equipment or other materials or equipment. CONTRACTOR shall assume full responsibility for any damage to the Site or the other areas, or to the owner or occupant thereof, or of any adjacent land or areas, resulting from the performance of the Work.

**B.** Should any claim be made by any such owner or occupant because of the performance of the Work, CONTRACTOR shall promptly settle with such other party by negotiation or otherwise resolve the claim by arbitration or other dispute resolution proceeding or at law. In case of a failure on the part of the CONTRACTOR to restore such property or to make good such damage or injuries, the CITY may, upon forty-eight (48) hours written notice to the CONTRACTOR, repair, rebuild or otherwise restore such property as the CITY may deem necessary, and the cost thereof will be deducted from any moneys due or which may become due the CONTRACTOR under this Contract.

**C.** CONTRACTOR shall, to the fullest extent permitted by Laws or Regulations, defend, indemnify and hold harmless CITY, DESIGN PROFESSIONAL, Consultants and the officers, directors, employees, agents and other consultants of each and any of them from and against all claims, costs, losses and damages (including but not limited to all fees and charges of engineers, architects, attorneys, and other professionals and all court or arbitration or other dispute resolution costs) arising out of or resulting from any claim or action, legal or equitable, brought by any such owner or occupant against CITY, DESIGN PROFESSIONAL or any other party indemnified hereunder to the extent caused by or based upon CONTRACTOR's performance of the Work.

**D.** During the progress of the Work, CONTRACTOR shall keep the Site and the other areas free from accumulations of waste materials, rubbish and other debris resulting from the Work. At the completion of the Work CONTRACTOR shall remove all waste materials, rubbish and debris from Site and other areas as well as all tools, appliances, construction equipment and machinery and surplus materials. CONTRACTOR shall leave the Site clean and ready for utilization or occupancy by CITY at Substantial Completion of the Work. CONTRACTOR shall restore to all property not designated for alteration by the Contract Documents to its pre-Work condition.

**E.** CONTRACTOR shall not load nor permit any part of any structure to be loaded in any manner that will endanger the structure, nor shall CONTRACTOR subject any part of the Work or adjacent property to stresses or pressures that will endanger it.

## **6.13 Record Documents**

**A.** CONTRACTOR shall maintain in a safe place at the Site one record copy of all Drawings, Specifications, Addenda, the Contract, Written Amendments, Change Orders, Work

Change Directives, and written interpretations and clarifications in good order and annotated to show all changes made during construction. These record documents, together with all approved Samples and a counterpart of all approved Shop Drawings, will be available to CITY and DESIGN PROFESSIONAL for reference. Upon completion of the Work, these record documents, Samples and Shop Drawings will be delivered to DESIGN PROFESSIONAL for CITY.

#### **6.14 Safety and Protection**

**A.** CONTRACTOR shall be solely responsible for initiating, maintaining and supervising all safety precautions and programs in connection with the Work. CONTRACTOR shall comply with all applicable Laws or Regulations relating to the safety of persons or property to protect them from damage, injury or loss; and shall erect and maintain all necessary safeguards for safety and protection. CONTRACTOR shall deliver to CITY a copy of CONTRACTOR'S Health and Safety Plan as provided in the Notice of Intent to Contract.

**B.** CONTRACTOR shall notify owners of adjacent property and of Underground Facilities and other utility owners when prosecution of the Work may affect them, and shall cooperate with them in the protection, removal, relocation and replacement of their property. All damage, injury or loss to any property referred to in Paragraph 6.14 B.2 or 6.14 B.3 caused, directly or indirectly, in whole or in part, by CONTRACTOR, any Subcontractor, Supplier or any other person or organization directly or indirectly employed by any of them to perform or furnish any of the Work or anyone for whose acts any of them may be liable, shall be remedied by CONTRACTOR (except damage or loss attributable to the fault of Drawings or Specifications or to the acts or omissions of CITY, DESIGN PROFESSIONAL, Consultant, or anyone employed by any of them or anyone for whose acts any of them may be liable, and not attributable, directly or indirectly, in whole or in part, to the fault or negligence of CONTRACTOR, Subcontractor, Supplier or other person or organization directly or indirectly employed by any of them). CONTRACTOR's duties and responsibilities for safety and for protection of the Work shall continue until such time as all the Work is completed and DESIGN PROFESSIONAL has issued a notice to CONTRACTOR in accordance with Paragraph 14.07 that the Work is acceptable (except as otherwise expressly provided in connection with Substantial Completion). CONTRACTOR shall take all necessary precautions for the safety of, and shall provide the necessary protection to prevent damage, injury or loss to:

1. all persons on the Site or who may be affected by the Work;
2. all the Work and materials and equipment to be incorporated therein, whether in storage on or off the Site; and
3. other property at the Site or adjacent thereto, including trees, shrubs, lawns, walks, pavements, roadways, structures, utilities and Underground Facilities not designated for removal, relocation or replacement in the course of the Work.

#### **6.15 Safety Representative**

**A.** In accordance with OSHA standards, CONTRACTOR shall designate a qualified and experienced safety representative whose duties and responsibilities shall be the prevention of accidents and the maintaining and supervising of safety precautions and programs. CONTRACTOR's safety representative shall remain at the Site whenever there is Work in progress and shall immediately notify CITY of any emergencies or accidents occurring at the Site

#### **6.16 Hazard Communication Programs**

**A.** CONTRACTOR shall be responsible for coordinating any exchange of material safety data sheets or other hazard communication information required to be made available to or exchanged between or among employers at the Site in accordance with Laws or Regulations.

## **6.17 Emergencies**

**A.** In emergencies affecting the safety or protection of persons or the Work or property at the Site or adjacent thereto, CONTRACTOR, without special instruction or authorization from CITY or DESIGN PROFESSIONAL, is obligated to act to prevent threatened damage, injury or loss. CONTRACTOR shall give CITY and DESIGN PROFESSIONAL prompt written notice if CONTRACTOR believes that any significant changes in the Work or variations from the Contract Documents have been caused thereby or are required as a result thereof. If CITY determines that a change in the Contract Documents is required because of the action taken by CONTRACTOR in response to an emergency, a Work Change Directive or Change Order will be issued.

**B.** A change in the Contract Documents pursuant to Paragraph 6.15 A will not be an automatic authorization of, nor a condition precedent to, entitlement to adjustment in the Contract Price or Contract Times. If CITY and CONTRACTOR are unable to agree on entitlement to, or magnitude of, an equitable adjustment in the Contract Price or Contract Times, a Claim may be made therefore as provided in Article 16. However, OWNER, DESIGN PROFESSIONAL and Consultants shall not be liable to CONTRACTOR for any costs, losses or damages (including but not limited to all fees and charges of engineers, architects, attorneys, and other professionals and all other dispute resolution costs) sustained by CONTRACTOR on or in connection with any other project or anticipated project.

## **6.18 Shop Drawings and Samples**

**A.** CONTRACTOR shall submit Shop Drawings to DESIGN PROFESSIONAL for review and approval in accordance with the accepted schedule of Shop Drawings and Sample submittals (see Paragraph 2.07). All submittals shall be identified as DESIGN PROFESSIONAL may require and in the number of copies specified in the General Requirements. The data shown on the Shop Drawings shall be complete with respect to quantities, dimensions, specified performance and design criteria, materials and similar data to show DESIGN PROFESSIONAL the services, materials and equipment CONTRACTOR proposes to provide and to enable DESIGN PROFESSIONAL to review the information for the limited purposes required by Paragraph 6.18 D.

**B.** CONTRACTOR shall also submit Samples to DESIGN PROFESSIONAL for review and approval in accordance with said accepted schedule of Shop Drawings and Sample submittals. Each Sample shall be identified clearly as to material, Supplier, pertinent data such as catalog numbers and the use for which intended and otherwise as DESIGN PROFESSIONAL may require to enable DESIGN PROFESSIONAL to review the submittal for the limited purposes required by Paragraph 6.18 D. The numbers of each Sample to be submitted will be as specified in the Specifications.

### **C. Submittal Procedures:**

1. Before submitting each Shop Drawing or Sample, CONTRACTOR shall have determined and verified:

a. all field measurements, quantities, dimensions, specified performance criteria, installation requirements, materials, catalog numbers and similar information with respect thereto;

b. all materials with respect to intended use, fabrication, shipping, handling, storage, assembly and installation pertaining to the performance of the Work;

c. all information relative to means, methods, techniques, sequences and procedures of construction and safety precautions and programs incident thereto; and

d. CONTRACTOR shall also have reviewed and coordinated each Shop Drawing or Sample with other Shop Drawings and Samples and with the requirements of the Work and the Contract Documents.

2. Each submittal shall bear a stamp or specific written indication that CONTRACTOR has satisfied CONTRACTOR's obligations under the Contract Documents with respect to CONTRACTOR's review and approval of that submittal.

3. At the time of each submission, CONTRACTOR shall give DESIGN PROFESSIONAL specific written notice of such variations, if any, that the Shop Drawing or Sample submitted may have from the requirements of the Contract Documents, the notice to be in a written communication separate from the submittal, and, in addition, shall cause a specific notation to be made on each Shop Drawing and Sample submitted to DESIGN PROFESSIONAL for review and approval of each such variation.

#### **D. DESIGN PROFESSIONAL's Review:**

1. DESIGN PROFESSIONAL will review and approve Shop Drawings and Samples in accordance with the schedule of Shop Drawings and Sample submittals accepted by DESIGN PROFESSIONAL as required by Paragraph 2.06. DESIGN PROFESSIONAL's review and approval will be only to determine if the items covered by the submittals will, after installation or incorporation into the Work, conform to the information given in the Contract Documents and be compatible with the design concept of the completed Project as a functioning whole as indicated by the Contract Documents.

2. DESIGN PROFESSIONAL's review and approval will not extend to means, methods, techniques, sequences or procedures of construction (except where a particular means, method, technique, sequence or procedure of construction is specifically and expressly called for by the Contract Documents) or to safety precautions or programs incident thereto. The review and approval of a separate item as such will not indicate approval of the assembly in which the item functions.

3. DESIGN PROFESSIONAL's review and approval of Shop Drawings or Samples shall not relieve CONTRACTOR from responsibility for any variation from the requirements of the Contract Documents unless CONTRACTOR has in writing called DESIGN PROFESSIONAL's attention to each such variation at the time of submission as required by Paragraph 6.18 C.3, and DESIGN PROFESSIONAL has given written approval of each such variation by specific written notation thereof incorporated into or accompanying the Shop Drawing or Sample approval; nor will any approval by DESIGN PROFESSIONAL relieve CONTRACTOR from responsibility for complying with the requirements of Paragraph 6.18 C.1.

**E.** Where a Shop Drawing or Sample is required by the Contract Documents or the schedule of Shop Drawings and Sample submissions accepted by DESIGN PROFESSIONAL as required by Paragraph 2.06, any related Work performed prior to DESIGN PROFESSIONAL's review and approval of the pertinent submittal will be at the sole expense and responsibility of CONTRACTOR.

**F.** CONTRACTOR shall make corrections required by DESIGN PROFESSIONAL and shall return the required number of corrected copies of Shop Drawings and submit as required new Samples for review and approval. CONTRACTOR shall direct specific attention in writing to revisions other than the corrections called for by DESIGN PROFESSIONAL on previous submittals.

#### **6.19 Continuing the Work**

**A.** CONTRACTOR shall carry on the Work and adhere to the progress schedule during all disputes or disagreements with CITY. No Work shall be delayed or postponed pending resolution of any disputes or disagreements, except as permitted by Paragraph 15.04 or as CITY and CONTRACTOR may otherwise agree in writing.

#### **6.20 CONTRACTOR's General Warranty and Guarantee**

**A.** CONTRACTOR warrants and guarantees to CITY, DESIGN PROFESSIONAL and Consultants that all Work will be in accordance with the Contract Documents and will not be

defective. CONTRACTOR's warranty and guarantee hereunder excludes defects or damage caused by:

1. abuse, modification or improper maintenance or operation by persons other than CONTRACTOR, Subcontractors, Suppliers or any other individual or entity for whom CONTRACTOR is responsible; or
2. normal wear and tear under normal usage.

**B.** CONTRACTOR's obligation to perform and complete the Work in accordance with the Contract Documents shall be absolute. None of the following will constitute an acceptance of Work that is not in accordance with the Contract Documents or a release of CONTRACTOR's obligation to perform the Work in accordance with the Contract Documents:

1. observations by DESIGN PROFESSIONAL;
2. recommendation of any progress or final payment by DESIGN PROFESSIONAL;
3. the issuance of a certificate of Substantial Completion or any payment related thereto by CITY to CONTRACTOR;
4. use or occupancy of the Work or any part thereof by OWNER;
5. any review and approval of a Shop Drawing or Sample submittal or the issuance of a notice of acceptability by DESIGN PROFESSIONAL;
6. any inspection, test or approval by others; or
7. any correction of defective Work by CITY.

**C.** Nonconforming Work is rejected unless expressly accepted in writing by the CITY's Representative.

## **ARTICLE 7 OTHER WORK**

### **7.01 Related Work at Site**

**A.** CITY may perform other work related to the Project at the Site by CITY's own forces, or let other direct contracts therefore, or have other work performed by utility owners. If such other work is to be performed and such fact was not noted in the Contract Documents, then:

1. Written notice thereof will be given to CONTRACTOR prior to starting any such other work, and
2. CONTRACTOR may make a Claim therefore as provided in Article 16 if CONTRACTOR believes that such performance involves additional expense to CONTRACTOR or requires additional time and the parties are unable to agree as to the amount or extent thereof.

**B.** CONTRACTOR shall afford each other contractor who is a party to such a direct contract, and each utility owner (and CITY, if CITY is performing the additional work with CITY's employees) proper and safe access to the Site and a reasonable opportunity for the introduction and storage of materials and equipment and the execution of such other work and shall properly connect and coordinate the Work with theirs. Unless otherwise provided in the Contract Documents, CONTRACTOR shall do all cutting, fitting and patching of the Work that may be required to properly connect or otherwise make its several parts come together and properly integrate with such other work. CONTRACTOR shall not endanger any work of others by cutting, excavating or otherwise altering their work and will only cut or alter their work with the written consent of CITY and the others whose work will be affected. The duties and responsibilities of CONTRACTOR under this Paragraph are for the benefit of such utility owners and other contractors to the extent that there are comparable provisions for the benefit of CONTRACTOR in said direct contracts between CITY and such utility owners and other contractors.

C. If the proper execution or results of any part of CONTRACTOR's Work depends upon work performed by others under this Article 7, CONTRACTOR shall inspect such other work and promptly report to CITY and DESIGN PROFESSIONAL in writing any delays, defects or deficiencies in such other work that render it unavailable or unsuitable for the proper execution or results of CONTRACTOR's Work. CONTRACTOR's failure to report same will constitute an acceptance of such other work as fit and proper for integration with CONTRACTOR's Work, except for latent or non-apparent defects and deficiencies in such other work.

## **7.02 Coordination**

A. If CITY contracts with others for the performance of other work on the Project at the Site, the following will be set forth in Supplementary Conditions:

1. the person, firm or corporation who will have authority and responsibility for coordination of the activities among the various prime contractors will be identified;
2. the specific matters to be covered by such authority and responsibility will be itemized; and
3. the extent of such authority and responsibilities will be provided.

B. Unless otherwise provided in the Supplementary Conditions, CITY shall have sole authority and responsibility in respect of such coordination.

## **ARTICLE 8 CITY'S RESPONSIBILITIES**

### **8.01 Communications to CONTRACTOR**

A. Except as otherwise provided in these General Conditions, CITY shall issue all communications to CONTRACTOR.

### **8.02 Replacement of DESIGN PROFESSIONAL**

A. In case of termination of the employment of DESIGN PROFESSIONAL, CITY shall appoint a DESIGN PROFESSIONAL whose status under the Contract Documents shall be that of the former DESIGN PROFESSIONAL.

### **8.03 Furnish Data and Prompt Payment**

A. CITY shall promptly furnish the data required of OWNER under the Contract Documents and shall make payments to CONTRACTOR when they are due.

### **8.04 Lands and Easements; Reports and Tests**

A. CITY's duties in respect of providing lands and easements and providing engineering surveys to establish reference points are set forth in Paragraphs 4.01 and 4.05. Paragraph 4.02 refers to CITY's duty to identify and make available to CONTRACTOR copies of reports of explorations and tests of subsurface conditions at the Site and drawings of physical conditions in existing structures at or contiguous to the Site that have been utilized by DESIGN PROFESSIONAL in preparing the Contract Documents.

### **8.05 Insurance**

A. CITY's responsibilities, if any, for purchasing and maintaining liability and property insurance are set forth in Article 5 and the Supplementary Conditions.

### **8.06 Change Orders**

A. CITY is obligated to execute Change Orders as indicated in Paragraph 10.03.

### **8.07 Inspections, Tests and Approvals**

A. CITY's responsibility for certain inspections, tests and approvals is set forth in Paragraph 13.02 F.

## **8.08 Limitations on CITY's Responsibilities**

A. The CITY shall not supervise, direct or have control or authority over, nor be responsible for, CONTRACTOR's means, methods, techniques, sequences or procedures of construction, or the safety precautions and programs incident thereto, or for any failure of CONTRACTOR to comply with Laws or Regulations applicable to the furnishing or performance of the Work. CITY will not be responsible for CONTRACTOR's failure to perform or furnish the Work in accordance with the Contract Documents.

## **8.09 Undisclosed Hazardous Environmental Condition**

A. CITY's responsibility for an undisclosed Hazardous Environmental Condition uncovered or revealed at the Site is set forth in Paragraph 4.06.

## **8.10 Evidence of Financial Arrangements**

A. CITY will furnish CONTRACTOR reasonable evidence that financial arrangements have been made to satisfy OWNER's obligations under the Contract.

## **8.11 CITY's Representative**

A. CITY will provide a representative during the construction period. The duties, responsibilities and the limitations of authority of the CITY "'s Representative during construction are set forth in the Contract Documents.

## **8.12 Visits to Site**

A. CITY's Representative will make visits to the Site at intervals appropriate to the various stages of construction as CITY's Representative deems necessary in order to observe the progress that has been made and the quality of the various aspects of CONTRACTOR's executed Work. Based on information obtained during such visits and observations, CITY's Representative will endeavor to determine, in general, if the Work is proceeding in accordance with the Contract Documents. CITY's Representative will not be required to make exhaustive or continuous on-Site inspections to check the quality or quantity of the Work.

# **ARTICLE 9 DESIGN PROFESSIONAL's STATUS DURING CONSTRUCTION**

## **9.01 General Scope of DESIGN PROFESSIONAL's Duties**

A. DESIGN PROFESSIONAL's efforts will be directed toward providing for CITY a greater degree of confidence that the completed Work will conform generally to the Contract Documents. On the basis of visits to the Site and on-Site observations, DESIGN PROFESSIONAL will keep CITY informed of the progress of the Work and will endeavor to guard CITY against defective Work. DESIGN PROFESSIONAL's visits to the Site and on-Site observations are subject to all the limitations on DESIGN PROFESSIONAL's authority and responsibility set forth in Paragraph 9.08.

## **9.02 Resident Project Representative**

A. If CITY and DESIGN PROFESSIONAL agree, DESIGN PROFESSIONAL will furnish a resident Project representative to assist DESIGN PROFESSIONAL in providing more extensive observation of the Work. The responsibilities, authority and limitations thereon of any such resident Project representative and assistants will be as provided in Paragraph 9.08 and in the Supplementary Conditions.

## **9.03 Clarifications and Interpretations**

A. DESIGN PROFESSIONAL will issue with reasonable promptness written clarifications or interpretations (which may be in the form of Drawings) of the requirements of the Drawings and Specifications prepared by the DESIGN PROFESSIONAL as DESIGN PROFESSIONAL may determine necessary, which shall be consistent with the intent of and reasonably inferable from the Contract Documents. Such written clarifications and interpretations will be binding on CITY and CONTRACTOR. If CITY or CONTRACTOR believes that a written clarification or

interpretation justifies an adjustment in the Contract Price pursuant to Article 11 and/ or the Contract Times pursuant to Article 12 and the parties are unable to agree to the amount or extent thereof, if any, a Claim may be made therefore as provided in Article 16.

#### **9.04 Rejecting Defective Work**

A. DESIGN PROFESSIONAL will have authority to disapprove or reject Work which DESIGN PROFESSIONAL believes to be defective, that DESIGN PROFESSIONAL believes will not produce a completed Project that conforms to the Contract Documents, or that will prejudice the integrity of the design concept of the completed Project as a functioning whole as indicated by the Contract Documents. DESIGN PROFESSIONAL will also have authority to require special inspection or testing of the Work as provided in Paragraph 13.04 B, whether or not the Work is fabricated, installed or completed.

#### **9.05 Shop Drawings, Change Orders and Payments**

A. In connection with DESIGN PROFESSIONAL's authority as to Shop Drawings and Samples, see Paragraph 6.18.

B. In connection with DESIGN PROFESSIONAL's authority as to Change Orders, see Article 10.

C. In connection with DESIGN PROFESSIONAL's authority as to Applications for Payment, see Article 14.

#### **9.06 Determinations for Unit Prices**

A. DESIGN PROFESSIONAL will initially determine the actual quantities and classifications of Unit Price Work performed by CONTRACTOR. DESIGN PROFESSIONAL will review with CONTRACTOR the DESIGN PROFESSIONAL's preliminary determinations on such matters before rendering a written opinion thereon (by recommendation of an Application for Payment or otherwise to the CITY). CITY reserves the right to make a final determination of the actual quantities and classifications of Unit Price Work in reviewing an Application for Payment. Within ten (10) days after the date of receipt of any such decision, CONTRACTOR may deliver to CITY and to DESIGN PROFESSIONAL written notice of intention to appeal CITY's decision pursuant to Article 16.

#### **9.07 Decisions on Requirements of Contract Documents and Acceptability of Work**

A. DESIGN PROFESSIONAL will be the initial interpreter of the requirements of the Drawings and Specifications prepared by DESIGN PROFESSIONAL and judge of the acceptability of the Work thereunder.

B. When functioning as interpreter and judge under this Paragraph 9.07, DESIGN PROFESSIONAL will not show partiality to OWNER or CONTRACTOR.

C. Claims, disputes and other matters relating to the acceptability of the Work, quantities and classifications of Unit Price Work, or the interpretation of the requirements of the Contract Documents pertaining to the performance and furnishing of the Work will be referred initially to CITY's Representative in writing with a request for a formal decision in accordance with Article 16.

#### **9.08 Limitations on DESIGN PROFESSIONAL's Authority and Responsibilities**

A. Neither DESIGN PROFESSIONAL's authority or responsibility under this Article 9 or under any other provision of the Contract Documents nor any decision made by DESIGN PROFESSIONAL in good faith either to exercise or not exercise such authority or responsibility or the undertaking, exercise or performance of any authority or responsibility by DESIGN PROFESSIONAL shall create, impose or give rise to any duty owed by DESIGN PROFESSIONAL to CONTRACTOR, any Subcontractor, any Supplier, any other person or organization, or to any surety for or employee or agent of any of them.



**B.** DESIGN PROFESSIONAL will not supervise, direct, control or have authority over or be responsible for CONTRACTOR's means, methods, techniques, sequences or procedures of construction, or the safety precautions and programs incident thereto, or for any failure of CONTRACTOR to comply with Laws or Regulations applicable to the furnishing or performance of the Work. DESIGN PROFESSIONAL will not be responsible for CONTRACTOR's failure to perform or furnish the Work in accordance with the Contract Documents.

**C.** DESIGN PROFESSIONAL will not be responsible for the acts or omissions of CONTRACTOR or of any Subcontractor, any Supplier, or of any other person or organization performing or furnishing any of the Work.

**D.** DESIGN PROFESSIONAL's review of the final Application for Payment and accompanying documentation, and all maintenance and operating instructions, schedules, guarantees, Bonds and certificates of inspection, tests and approvals and other documentation required to be delivered by Paragraph 14.07 will only be to determine generally that their content complies with the requirements of, and in the case of certificates of inspections, tests and approvals, that the results certified indicate compliance with, the Contract Documents.

**E.** The limitations upon authority and responsibility set forth in this Paragraph 9.08 shall also apply to DESIGN PROFESSIONAL's Consultants, resident Project representative and assistants as identified in the Supplementary Conditions.

## **ARTICLE 10 CHANGES IN THE WORK**

### **10.01 Authorized Changes in the Work**

**A.** Without invalidating the Contract and without notice to any surety, CITY may, at any time or from time to time, order additions, deletions or revisions in the Work. Such additions, deletions or revisions will be authorized by a Written Amendment, a Change Order, or a Work Change Directive. Upon receipt of any such document, CONTRACTOR shall promptly proceed with the Work involved that will be performed under the applicable conditions of the Contract Documents (except as otherwise specifically provided).

**B.** If CITY and CONTRACTOR are unable to agree on entitlement to, or on the amount or extent, if any, of an adjustment in the Contract Price pursuant to Article 11 or an adjustment of the Contract Times pursuant to Article 12 or both that should be allowed as a result of a Work Change Directive, a Claim may be made therefore as provided in Article 16.

### **10.02 Unauthorized Changes in the Work**

**A.** CONTRACTOR shall not be entitled to an increase in the Contract Price or an extension of the Contract Times with respect to any work performed that is not required by the Contract Documents as amended, modified or supplemented as provided in Paragraph 3.04, except in the case of an emergency as provided in Paragraph 6.17 or in the case of uncovering Work as provided in Paragraph 13.04.

### **10.03 Signing of Change Orders**

**A.** CITY and CONTRACTOR, and DESIGN PROFESSIONAL shall sign appropriate Change Orders covering:

1. changes in the Work which are:
  - a. ordered by CITY pursuant to Paragraph 10.01 A; or
  - b. required because of acceptance of defective Work under Paragraph 13.08 or correcting defective Work under Paragraph 13.09; or
  - c. agreed to by the parties;
2. changes in the Contract Price or Contract Times or both which are agreed to by the parties, including any undisputed sum or amount of time for Work actually performed in accordance with a Work Change Directive; and

3. changes in the Contract Price or Contract Times or both which embody the substance of any written decision recommended by DESIGN PROFESSIONAL and approved by CITY pursuant to Paragraph 9.06, provided that, in lieu of signing any such Change Order, an appeal may be taken from any such decision in accordance with the provisions of the Contract Documents and applicable Laws or Regulations, but during any such appeal, CONTRACTOR shall carry on the Work and adhere to the progress schedule as provided in Paragraph 6.19.

#### **10.04 Notification to Surety**

A. If notice of any change affecting the general scope of the Work or the provisions of the Contract Documents (including, but not limited to, Contract Price or Contract Times or both) is required by the provisions of any Bond to be given to a surety, the giving of any such notice will be CONTRACTOR's responsibility, and the amount of each applicable Bond will be adjusted accordingly.

### **ARTICLE 11 CHANGE OF CONTRACT PRICE**

#### **11.01 Change of Contract Price**

A. The Contract Price constitutes the total compensation (subject to authorized adjustments) payable to CONTRACTOR for performing the Work. All duties, responsibilities and obligations assigned to or undertaken by CONTRACTOR shall be at CONTRACTOR's expense without change in the Contract Price.

B. The Contract Price may only be changed by a Change Order. Any request for an adjustment in the Contract Price shall be based on written notice delivered within fourteen (14) calendar days after occurrence of the event giving rise to the request or within fourteen (14) calendar days after first recognition of the conditions giving rise to the request. Prior notice is not required for requests or claims relating to an emergency endangering life or property as described in Paragraph 6.16. Thereafter, the CONTRACTOR shall submit written documentation of its request, including appropriate supporting documentation, within ten (10) calendar days after giving notice, unless the CITY grants an extension based on good cause shown by the CONTRACTOR that such additional time is warranted.

C. The value of any Work covered by a Change Order or of any request for an adjustment in the Contract Price will be determined as follows:

1. where the Work involved is covered by Unit Prices contained in the Contract Documents, by application of such Unit Prices to the quantities of the items involved (subject to the provisions of Paragraph 11.04); or

2. where the Work involved is not covered by Unit Prices contained in the Contract Documents, by a mutually agreed lump sum; or

3. where the Work involved is not covered by Unit Prices contained in the Contract Documents and agreement to a lump sum is not reached under Paragraph 11.01 C.2, on the basis of the Cost of the Work (determined as provided in Paragraphs 11.02 A and B) plus a CONTRACTOR's fee for overhead and profit (determined as provided in Paragraph 11.01 D).

D. The CONTRACTOR's fee allowed to CONTRACTOR for overhead and profit shall be determined as follows:

1. a mutually acceptable fixed fee; or

2. if a fixed fee is not agreed upon, then a fee based on the following percentages of the various portions of the Cost of the Work:

a. for costs incurred under Paragraphs 11.02 A.1 and 11.02 A.2, the CONTRACTOR's fee shall be ten percent (10%);

b. for costs incurred under Paragraph 11.02 A.3, the CONTRACTOR's fee shall be five percent (5%);

c. where one or more tiers of subcontracts are on the basis of the Cost of the Work plus a fee and no fixed fee is agreed upon, the intent of Paragraphs 11.01 D.2 and 11.02 A.1 through A.3 is that the Subcontractor who actually performs or furnishes the Work, at whatever tier, will be paid a fee of ten percent (10%) of the costs incurred by such Subcontractor under Paragraphs 11.02 A.1 and 11.02 A.2 and that any higher tier Subcontractor and CONTRACTOR will each be paid a fee of five percent (5%) of the amount paid to the next lower tier Subcontractor;

d. no fee shall be payable on the basis of costs itemized under Paragraphs 11.02 A.4, 11.02 A.5 and 11.02 B;

e. the amount of credit to be allowed by CONTRACTOR to CITY for any change which results in a net decrease in cost will be the amount of the actual net decrease in costs plus a deduction in CONTRACTOR's fee by an amount equal to five percent (5%) of such net decrease; and

f. when both additions and credits are involved in any one change, the adjustment in CONTRACTOR's fee shall be computed on the basis of the net change in accordance with Paragraphs 11.01 D.2.a through 11.01 D.2.e, inclusive.

**E.** Whenever the Cost of the Work is to be determined pursuant to Paragraphs 11.02 A and B, CONTRACTOR shall establish and maintain records thereof in accordance with generally accepted accounting practices and submit in form acceptable to CITY an itemized cost breakdown together with supporting data.

## **11.02 Cost of the Work**

**A.** The term "Cost of the Work" means the sum of all costs necessarily incurred and paid by CONTRACTOR in the proper performance of the Work. When the value of any Work covered by a Change Order or when a request for an adjustment in Contract Price is determined on the basis of Cost of the Work, the costs to be reimbursed to CONTRACTOR will be only those additional or incremental costs required because of the change in the Work or because of the event giving rise to the request. Except as otherwise agreed to in writing by CITY, costs covered by Change Orders or requests shall be in amounts no higher than those prevailing in the locality of the Project, shall include only the following items and shall not include any costs itemized in 11.02 B:

1. Payroll costs for employees in the direct employ of CONTRACTOR in the performance of the Work, using occupational titles and job classifications agreed upon by CITY and CONTRACTOR. Such employees shall include, without limitation, job Site superintendents, foremen and other personnel employed full time at the Site. Payroll costs for employees not employed full time on the Work shall be apportioned on the basis of their time spent on the Work. Payroll costs shall include, but not be limited to, salaries and wages plus the cost of fringe benefits which shall include social security contributions, unemployment, excise and payroll taxes, workers' compensation, health and retirement benefits, bonuses, sick leave, vacation and holiday pay applicable thereto. The expenses of performing the Work after regular working hours, on Saturdays, Sundays or legal holidays, shall be included in the above to the extent authorized by OWNER.

2. Cost of all materials and equipment furnished and incorporated into the Work, including costs of transportation and storage thereof, and Suppliers' field services required in connection therewith. All cash discounts shall accrue to CONTRACTOR unless CITY deposits funds with CONTRACTOR with which to make payments, in which case the cash discounts shall accrue to CITY. All trade discounts, rebates and refunds and returns from sale of surplus materials and equipment shall accrue to CITY, and CONTRACTOR shall make provisions so that they may be obtained.

3. Payments made by CONTRACTOR to Subcontractors for Work performed or furnished by Subcontractors. If required by CITY, CONTRACTOR shall obtain competitive bids from Subcontractors acceptable to OWNER and CONTRACTOR and shall deliver such bids to CITY who will then determine, with the advice of DESIGN PROFESSIONAL, which bids, if any, will be accepted. If any subcontract provides that the Subcontractor is to be paid on the basis of the Cost of the Work plus a fee, the Subcontractor's Cost of the Work and fee shall be determined in the same manner as CONTRACTOR's Cost of the Work and fee as provided in Paragraphs 11.01 D and E and 11.02 A and B. All subcontracts shall be subject to the other provisions of the Contract Documents insofar as applicable.

4. Costs of special consultants (including but not limited to engineers, architects, testing laboratories, surveyors, attorneys and accountants) employed for services specifically related to the Work when such services are approved in advance by CITY in writing.

5. Other costs including the following:

a. The proportion of necessary transportation, travel and subsistence expenses of CONTRACTOR's employees incurred in discharge of duties connected with the Work.

b. Cost, including transportation and maintenance, of all materials, supplies, equipment, machinery, appliances, office and temporary facilities at the Site and hand tools not owned by the workers, which are consumed in the performance of the Work, and cost, less market value of such items used but not consumed which remain the property of CONTRACTOR.

c. Rentals of all construction equipment and machinery and the parts thereof whether rented from CONTRACTOR or others in accordance with rental agreements approved by CITY with the advice of DESIGN PROFESSIONAL, and the costs of transportation, loading, unloading, installation, assembly, dismantling and removal thereof, all in accordance with the terms of said rental agreements. The rental of any such equipment, machinery or parts shall cease when the use thereof is no longer necessary for the Work.

d. Applicable sales, consumer, use or similar taxes related to the Work, and for which CONTRACTOR is liable, imposed by Laws or Regulations.

e. Deposits lost for causes other than negligence of CONTRACTOR, any Subcontractor or anyone directly or indirectly employed by any of them or for whose acts any of them may be liable, and royalty payments and fees for permits and licenses required to perform the Work.

f. Losses and damages (and related expenses) caused by damage to the Work, not compensated by insurance or otherwise, sustained by CONTRACTOR in connection with the performance and furnishing of the Work (except losses and damages within the deductible amounts of property insurance established by CITY in accordance with Article 5), provided they have resulted from causes other than the negligence of CONTRACTOR, any Subcontractor, or anyone directly or indirectly employed by any of them or for whose acts any of them may be liable. Such losses shall include settlements made with the written consent and approval of CITY. No such losses, damages and expenses shall be included in the Cost of the Work for the purpose of determining CONTRACTOR's fee. If, however, any such loss or damage requires reconstruction and CONTRACTOR is placed in charge thereof, CONTRACTOR shall be paid for those services a fee proportionate to that stated in Paragraph 11.01 D.2.

g. The cost of utilities, fuel and sanitary facilities at the Site.

h. Minor expenses such as telegrams, long distance telephone calls, telephone service at the Site, expressage and similar petty cash items in connection with the Work.

i. Cost of premiums for additional or increased Bonds, or for insurance required because of approved changes in the Work.

**B. Costs excluded:** The term “Cost of the Work” shall not include any of the following:

1. Payroll costs and other compensation of CONTRACTOR's officers, executives, principals (of partnership and sole proprietorships), general managers, engineers, architects, estimators, attorneys, auditors, accountants, purchasing and contracting agents, expeditors, timekeepers, clerks and other personnel employed by CONTRACTOR whether at the Site or in CONTRACTOR's principal or a branch office for general administration of the Work (if not specifically included in the agreed upon occupational titles and job classifications referred to in Paragraph 11.02 A.1 or specifically covered by Paragraph 11.02 A.4), all of which are to be considered administrative costs covered by the CONTRACTOR's fee.

2. Expenses of CONTRACTOR's principal and branch offices other than CONTRACTOR's office at the Site.

3. Any part of CONTRACTOR's capital expenses, including interest on CONTRACTOR's capital employed for the Work and charges against CONTRACTOR for delinquent payments.

4. Costs due to the negligence of CONTRACTOR, any Subcontractor, or anyone directly or indirectly employed by any of them or for whose acts any of them may be liable, including but not limited to, the correction of defective Work, disposal of materials, or equipment wrongly supplied, and making good any damage to property.

5. Other overhead or general expense costs of any kind and the costs of any item not specifically and expressly included in Paragraph 11.02 A.

### **11.03 Cash Allowances**

**A.** It is understood that CONTRACTOR has included in the Contract Price all allowances so named in the Contract Documents and shall cause the Work so covered to be furnished and performed for such sums as may be acceptable to CITY. CONTRACTOR agrees that:

1. the allowances include the cost to CONTRACTOR (less any applicable trade discounts) of materials and equipment required by the allowances to be delivered at the Site, and all applicable taxes; and

2. CONTRACTOR's costs for unloading and handling on the Site, labor, installation costs, overhead, profit and other expenses contemplated for the allowances have been included in the Contract Price and not in the allowances, and no demand for additional payment on account of any of the foregoing will be valid.

**B.** Prior to final payment, an appropriate Change Order will be issued by CITY to reflect actual amounts due CONTRACTOR on account of Work covered by allowances, and the Contract Price shall be correspondingly adjusted.

### **11.04 Unit Price Work**

**A.** Where the Contract Documents provide that all or part of the Work is to be Unit Price Work, initially the Contract Price will be deemed to include for all Unit Price Work an amount equal to the sum of the established unit price for each separately identified item of Unit Price Work times the estimated quantity of each item as indicated in the Contract. The estimated quantities of items of Unit Price Work are not guaranteed and are solely for the purpose of comparison of Bids and determining an initial Contract Price. Determinations of the actual quantities and classifications of Unit Price Work performed by CONTRACTOR will be made in accordance with Paragraph 9.06.

**B.** Each unit price will be deemed to include an amount considered by CONTRACTOR to be adequate to cover CONTRACTOR's overhead and profit for each separately identified item.

**C.** CITY or CONTRACTOR may negotiate an adjustment of the price per unit of Unit Price Work stated in the Contract if:

1. the quantity of any item of Unit Price Work performed by CONTRACTOR differs by twenty percent (20%) or more from the estimated quantity of such item indicated in the Contract; and

2. there is no corresponding adjustment with respect to any other item of Work; and

3. CONTRACTOR believes that CONTRACTOR is entitled to an increase in Contract Price as a result of having incurred additional expense or CITY believes that CITY is entitled to a decrease in Contract Price.

#### **11.05 Dispute Resolution**

A. If CITY and CONTRACTOR are unable to agree on entitlement to, or magnitude of, an equitable adjustment in the Contract Price in accordance with Article 11 within fourteen (14) calendar days from the receipt of supporting documentation of the request pursuant to 11.01.B., unless the CITY grants an extension based on good cause shown by the CONTRACTOR that such additional time is warranted, then a Claim for such adjustment may be made pursuant to Article 16.

### **ARTICLE 12 CONTRACT TIMES**

#### **12.01 Time of the Essence**

A. All times stated in the Contract Documents are of the essence of the Contract.

#### **12.02 Change of Contract Times**

A. The Contract Times (or Milestones) may only be changed by a Change Order. Any request for an adjustment in the Contract Times shall be based on written notice delivered within fourteen (14) calendar days after occurrence of the event giving rise to the request or within fourteen (14) calendar days after first recognition of the conditions giving rise to the request. Thereafter, the CONTRACTOR shall submit written documentation of its requests, including appropriate supporting documentation, within ten (10) days after giving notice, unless the CITY grants an extension based on good cause shown by the CONTRACTOR that such additional time is warranted.

#### **12.03 Proof Required To Justify an Extension of Time For Excusable and Compensable Delays**

A. In support of any request for an extension of the Contract Times pursuant to this Article, CONTRACTOR must demonstrate to the reasonable satisfaction of the CITY that the critical path of the approved baseline project schedule was delayed. CONTRACTOR shall be entitled to an increase in contract time for the number of days that the critical path was delayed solely as a result of the compensable or excusable event. A compensable or excusable event includes, but is not limited to:

1. unreasonable delay of issuance of Notice to Proceed by CITY;
2. CITY's unreasonable delay of delivery furnished materials, equipment, or work;
3. unreasonable delay responding to shop drawings and submittals;
4. CITY's unreasonable delay in issuing a Change Order;
5. an order by the CITY to stop the Work where the CONTRACTOR was not at fault; and
6. other reasonable grounds as determined by the City in its sole discretion.

B. CONTRACTOR shall compare the critical path of the approved baseline project schedule to the actual critical path of the Work, identifying the specific impact of the compensable or excusable event.

C. CONTRACTOR shall submit to the CITY a written time impact analysis illustrating the influence of each compensable or excusable event on the date of Substantial Completion. The

time impact analysis shall demonstrate the time impact based on the date of the delay in time and the event time computations or all affected activities.

**D.** If the critical path of the Work is delayed by “Force Majeure”, the CONTRACTOR shall be entitled only to an extension of the Contract Times for the number of days of delay to the critical path. For purposes of this paragraph, “Force Majeure” shall mean fire, tornado, flood, earthquake, war, act of terrorism, civil disturbance, or labor strikes away from the project site.

**E.** Extensions of contract time pursuant to the this section will be granted only to the extent that the time adjustments exceed the total float time available when the event causing the delay occurred.

#### **12.04 Delays Within CONTRACTOR’s Control**

**A.** The Contract Times (or Milestones) will not be extended due to delays within the control of CONTRACTOR. Delays attributable to and within the control of a Subcontractor or Supplier shall be deemed to be delays within the control of CONTRACTOR.

#### **12.05 Delays Beyond the CITY’s and CONTRACTOR’s Control**

**A.** Where CONTRACTOR is prevented from completing any part of the Work within the Contract Times (or Milestones) due to delay beyond the control of both CITY and CONTRACTOR, an extension of the Contract Times (or Milestones) in an amount equal to the time lost due to such delay shall be CONTRACTOR’s sole and exclusive remedy for such delay.

#### **12.06 Delay Damages**

**A.** In no event shall CITY be liable to CONTRACTOR, any Subcontractor, any Supplier, any other person or organization, or to any surety for or employee or agent of any of them, for damages arising out of or resulting from:

1. delays caused by or within the control of CONTRACTOR, or
2. delays beyond the control of CITY or CONTRACTOR including but not limited to fires, floods, epidemics, abnormal weather conditions, acts of God or acts or neglect by utility owners or other contractors performing other work as contemplated by Article 7.

**B.** Nothing in this Paragraph 12.06 bars a change in Contract Price pursuant to this Article 12 to compensate CONTRACTOR due to delay, interference, or disruption directly attributable to actions or inaction of CITY, DESIGN PROFESSIONAL, Consultant or anyone for whom CITY, DESIGN PROFESSIONAL or Consultant is responsible.

#### **12.07 Dispute Resolution**

**A.** If CITY and CONTRACTOR are unable to agree on entitlement to, or magnitude of, an equitable adjustment in the Contract Time in accordance with Article 12 within fourteen (14) calendar days from the receipt of supporting documentation of the request pursuant to 12.02, unless the CITY grants an extension based on good cause shown by the CONTRACTOR that such additional time is warranted, then a Claim for such adjustment may be made pursuant to Article 16.

### **ARTICLE 13 TESTS AND INSPECTIONS; CORRECTION, REMOVAL OR ACCEPTANCE OF DEFECTIVE WORK**

#### **13.01 Access to Work**

**A.** CITY, DESIGN PROFESSIONAL, Consultants, other representatives and personnel of CITY, independent testing laboratories and governmental agencies with jurisdictional interests will have access to the Site and Work at reasonable times for their observation, inspecting and testing. CONTRACTOR shall provide them proper and safe conditions for such access and advise them of CONTRACTOR’s Site safety procedures and programs so that they may comply therewith as applicable.

### **13.02 Tests and Inspections**

**A.** CONTRACTOR shall give DESIGN PROFESSIONAL and CITY's Representative timely notice of readiness of the Work for all required inspections, tests or approvals, and shall cooperate with inspection and testing personnel to facilitate required inspections or tests.

**B.** If any Work (or the work of others at the Site) that is to be inspected, tested or approved is covered by CONTRACTOR without written approval required by Paragraphs 13.02 D or 13.02 E, it must, if requested by CITY's Representative, be uncovered for observation.

**C.** Uncovering Work as provided in Paragraph 13.02 B, shall be at CONTRACTOR's expense unless CONTRACTOR has given DESIGN PROFESSIONAL and CITY's Representative timely notice of CONTRACTOR's intention to cover the same and DESIGN PROFESSIONAL and CITY's Representative have not acted with reasonable promptness in response to such notice.

**D.** If Laws or Regulations of any public body (including City) having jurisdiction require any Work (or part thereof) specifically to be inspected, tested or approved by an employee or other representative of such public body, CONTRACTOR shall assume full responsibility for arranging and obtaining such inspections, tests or approvals, pay all costs in connection therewith, and furnish DESIGN PROFESSIONAL and CITY's Representative the required certificates of inspection or approval.

**E.** CONTRACTOR shall be responsible for arranging and obtaining and shall pay all costs in connection with any inspections, tests or approvals required for CITY's and DESIGN PROFESSIONAL's acceptance of materials or equipment to be incorporated into the Work, or acceptance of materials, mix designs, or equipment submitted for approval prior to CONTRACTOR's purchase thereof for incorporation into the Work. Such inspections, tests, or approvals shall be performed by organizations acceptable to CITY and DESIGN PROFESSIONAL.

**F.** CITY shall employ and pay for the services of an independent testing laboratory to perform all inspections, tests, or approvals required by the Contract Documents except:

1. for inspections, tests or approvals covered by Paragraph 13.02 D and E;
2. that costs incurred in connection with tests or inspections conducted pursuant to Paragraph 13.04 B shall be paid as provided in said Paragraph 13.04 B; and
3. as otherwise specifically provided in the Contract Documents.

### **13.03 Notice of Defects**

**A.** Prompt notice of all defective Work of which either CITY or DESIGN PROFESSIONAL has actual knowledge will be given to CONTRACTOR. Defective Work may be rejected, corrected or accepted as provided in this Article 13.

### **13.04 Uncovering Work**

**A.** If any Work (or the work of others at the Site) is covered contrary to the written request of DESIGN PROFESSIONAL or CITY's Representative, it must, if requested by CITY's Representative, be uncovered for DESIGN PROFESSIONAL's or CITY's Representative's observation and replaced at CONTRACTOR's expense.

**B.** If CITY considers it necessary or advisable that covered Work be observed by DESIGN PROFESSIONAL or CITY's Representative or be inspected or tested by others, CONTRACTOR, at CITY's request, shall uncover, expose or otherwise make available for observation, inspection or testing as may be required, that portion of the Work in question, furnishing all necessary labor, material and equipment. If it is found that such Work is defective, CONTRACTOR shall pay all costs, losses and damages (including but not limited to all fees and charges of engineers, architects, attorneys, and other professionals and all court or arbitration or other dispute resolution costs) caused by, arising out of or resulting from such uncovering, exposure, observation, inspection and testing and of satisfactory replacement or reconstruction



(including but not limited to all costs of repair or replacement of work of others); and CITY shall be entitled to an appropriate decrease in the Contract Price. If the parties are unable to agree as to the amount thereof, CITY may make a Claim therefore as provided in Article 16. If, however, such Work is not found to be defective, CONTRACTOR shall be allowed an increase in the Contract Price or an extension of the Contract Times (or Milestones), or both, directly attributable to such uncovering, exposure, observation, inspection, testing, replacement and reconstruction. If the parties are unable to agree as to the amount or extent thereof, CONTRACTOR may make a Claim therefore as provided in Article 16.

### **13.05 CITY May Stop the Work**

**A.** If the Work is defective, or CONTRACTOR fails to supply sufficient skilled workers or suitable materials or equipment, or fails to furnish or perform the Work in such a way that the completed Work will conform to the Contract Documents, CITY may order CONTRACTOR to stop the Work, or any portion thereof, until the cause for such order has been eliminated; however, this right of CITY to stop the Work shall not give rise to any duty on the part of CITY to exercise this right for the benefit of CONTRACTOR, any Subcontractor, Supplier, other individual or entity or any surety or employee or agent of any of them.

### **13.06 Correction or Removal of Defective Work**

**A.** If required by CITY, CONTRACTOR shall promptly, as directed, either correct all defective Work, whether or not fabricated, installed or completed, or, if the Work has been rejected by either DESIGN PROFESSIONAL or CITY's Representative, remove it and replace it with Work that is not defective. CONTRACTOR shall pay all costs, losses and damages (including but not limited to all fees and charges of engineers, architects, attorneys, and other professionals and all court or arbitration or other dispute resolution costs) caused by or resulting from such correction or removal (including but not limited to all costs of repair or replacement of work of others).

### **13.07 Correction Period**

**A.** If within one (1) year after the date of Substantial Completion, or such longer period of time as may be prescribed by Laws or Regulations, by the terms of any applicable special guarantee required by the Contract Documents, or by any specific provision of the Contract Documents, any Work is found to be defective, or if the repair of any damages to the land or areas made available for CONTRACTOR's use by CITY or permitted by Laws and Regulations as contemplated in Paragraph 6.10 is found to be defective, CONTRACTOR shall promptly, without cost to CITY and in accordance with CITY's written instructions:

1. correct the repair of damages to such land or areas; or
2. correct such defective Work, or if it has been rejected by CITY, remove it from the Site and replace it with Work that is not defective; and
3. satisfactorily correct or remove and replace any damage to other Work or to the work of others or damage to other lands or areas resulting therefrom. If CONTRACTOR does not promptly comply with the terms of such instructions, or in the event of an emergency where delay by CONTRACTOR would cause serious risk of loss or damage, CITY may have the defective Work corrected or the rejected Work removed and replaced, and all costs, losses and damages (including but not limited to all fees and charges of engineers, architects, attorneys, and other professionals and all court or arbitration or other dispute resolution costs) caused by or resulting from such removal and replacement (including but not limited to all costs of repair or replacement of work of others) will be paid by CONTRACTOR.

**B.** In special circumstances where a particular item of equipment is placed in continuous service before Substantial Completion of all the Work, the correction period for that item may start to run from an earlier date if so provided in the Specifications or by Written Amendment.

**C.** Where defective Work (and damage to other Work resulting therefrom) has been corrected or removed and replaced under this Paragraph 13.07, the correction period hereunder

with respect to such Work will be extended for an additional period of one (1) year, or such longer period of time as may be prescribed within Paragraph 13.07 A, after such correction or removal and replacement has been satisfactorily completed.

D. CONTRACTOR's obligations under this Paragraph 13.07 are in addition to any other obligation or warranty. The provisions of this Paragraph 13.07 shall not be construed as a substitute for or waiver of the provisions of any applicable statute of limitation or repose.

### **13.08 Acceptance of Defective Work**

A. If, instead of requiring correction or removal and replacement of defective Work, CITY prefers to accept it, CITY may do so. CONTRACTOR shall pay all costs, losses and damages (including but not limited to all fees and charges of engineers, architects, attorneys, and other professionals and all court or arbitration or other dispute resolution costs) attributable to CITY's evaluation of and determination to accept such defective Work and shall pay OWNER for the diminished value of the Work. If any such acceptance occurs prior to DESIGN PROFESSIONAL's recommendation of final payment, a Change Order will be issued incorporating the necessary revisions into the Contract Documents with respect to the Work and, due to the diminished value of the Work, CITY shall be entitled to an appropriate decrease in the Contract Price. If the parties are unable to agree as to the amount thereof, CITY may make a Claim therefore as provided in Article 16. If the acceptance of defective Work occurs after such recommendation, an appropriate amount shall be paid by CONTRACTOR to CITY.

### **13.09 CITY May Correct Defective Work**

A. If CONTRACTOR fails within a reasonable time after written notice from DESIGN PROFESSIONAL or CITY's Representative to correct defective Work or to remove and replace rejected Work as required by CITY in accordance with Paragraph 13.06, or if CONTRACTOR fails to perform the Work in accordance with the Contract Documents, or if CONTRACTOR fails to comply with any other provision of the Contract Documents, CITY may, after seven (7) days written notice to CONTRACTOR, correct and remedy any such deficiency.

B. CITY shall proceed expeditiously when exercising the rights and remedies under this Paragraph 13.09. In connection with such corrective and remedial action, CITY may exclude CONTRACTOR from all or part of the Site; take possession of all or part of the Work and suspend CONTRACTOR's services related thereto; take possession of CONTRACTOR's tools, appliances, construction equipment and machinery at the Site; and incorporate into the Work all materials and equipment stored at the Site or for which CITY has paid CONTRACTOR but which are stored elsewhere. CONTRACTOR shall allow CITY, CITY's Representative, agents and employees, CITY's other contractors, DESIGN PROFESSIONAL and Consultants access to the Site to enable CITY to exercise the rights and remedies under this Paragraph 13.09.

C. All costs, losses and damages (including but not limited to all fees and charges of engineers, architects, attorneys, and other professionals and all court or arbitration or other dispute resolution costs) incurred or sustained by CITY in exercising such rights and remedies will be charged against CONTRACTOR and a Change Order will be issued incorporating the necessary revisions into the Contract Documents with respect to the Work; and CITY shall be entitled to an appropriate decrease in the Contract Price. If CITY and CONTRACTOR are unable to agree as to the amount thereof, CITY may make a Claim therefore as provided in Article 16. Such Claims for costs, losses and damages will include but not be limited to all costs of repair or replacement of work of others destroyed or damaged by correction, removal and replacement of CONTRACTOR's defective or rejected Work.

D. CONTRACTOR shall not be allowed an extension of the Contract Times (or Milestones) because of any delay in the performance of the Work attributable to the exercise by CITY of CITY's rights and remedies under Paragraphs 13.06 and 13.09.

## **ARTICLE 14 PAYMENTS TO CONTRACTOR AND COMPLETION**

### **14.01 Schedule of Values**

A. 01290.02 Schedule of Values established as provided in Article 2 will serve as the basis for progress payments and will be incorporated into form 01290.01 Application for Payment acceptable to DESIGN PROFESSIONAL and CITY. Progress payments for Unit Price Work will be based on the number of units completed.

#### **14.02 Application for Progress Payments**

##### **A. Application for Payment**

1. At least twenty (20) days before the date stipulated in the Supplementary Conditions for each progress payment (but not more often than once a month), CONTRACTOR shall submit to DESIGN PROFESSIONAL for review an Application for Payment filled out and signed by CONTRACTOR covering the Work completed as of the date of the Application and accompanied by such supporting documentation as is required by the Contract Documents. If payment is requested on the basis of materials and equipment not incorporated into the Work but delivered and suitably stored at the Site or at another location agreed to in writing, the Application for Payment shall also be accompanied by a bill of sale, paid invoice or other documentation warranting that CITY has received the materials and equipment free and clear of all Liens and evidence that the materials and equipment are covered by appropriate property insurance and other arrangements to protect CITY's interest therein, all of which will be subject to CITY's approval.

2. Beginning with the second Application for Payment, each Application shall include:

a. an affidavit of CONTRACTOR stating that all previous progress payments received for the Work have been applied to discharge CONTRACTOR's legitimate obligations associated with prior Applications for Payment, and

b. a copy of the most recent 00485.01 M/WBE Monthly Utilization Report CONTRACTOR has submitted to the CITY's Civil Rights and Equal Opportunity Department.

c. a copy of the most recent 00485.02 Project Workforce Monthly Report and 00485.03 Company-Wide Workforce Monthly Report CONTRACTOR has submitted to the OWNER's Civil Rights and Equal Opportunity Department.

d. an update to the approved schedule pursuant to paragraphs 6.04 and 6.05.

3. The amount of retainage with respect to progress payments will be stated in the Supplementary Conditions.

##### **B. Review of Applications**

1. DESIGN PROFESSIONAL will, within ten (10) days after receipt of each Application for Payment, either indicate in writing a recommendation of payment and present the Application to CITY, or return the Application to CONTRACTOR indicating in writing DESIGN PROFESSIONAL's reasons for refusing to recommend payment. In the latter case, CONTRACTOR shall make the necessary corrections and resubmit the Application.

a. After presentation of the Application for Payment to CITY, and if CITY's Representative agrees with DESIGN PROFESSIONAL's recommendation, the amount recommended will (subject to the provisions of Paragraph 14.02 B.4) become due and will be paid by CITY to CONTRACTOR, subject to the provisions of Laws or Regulations.

b. No payment shall be approved until the CONTRACTOR has submitted with the Application accompanying documentation as required by the Contract Documents, including, but not limited to, the documentation required by paragraphs 6.04 and 6.05.

2. DESIGN PROFESSIONAL's recommendation of any payment requested in an Application for Payment will constitute a representation by DESIGN PROFESSIONAL to CITY, based on DESIGN PROFESSIONAL's observations of the executed Work as an experienced and qualified DESIGN PROFESSIONAL and on DESIGN PROFESSIONAL's

review of the Application for Payment and the accompanying data and schedules, that to the best of DESIGN PROFESSIONAL's knowledge, information and belief:

- a. the Work has progressed to the point indicated;
- b. the quality of the Work is generally in accordance with the Contract Documents (subject to an evaluation of the Work as a functioning whole prior to or upon Substantial Completion, to the results of any subsequent tests called for in the Contract Documents, to a final determination of quantities and classifications for Unit Price Work under Paragraph 9.06, and to any other qualifications stated in the recommendation); and
- c. the conditions precedent to CONTRACTOR being entitled to such payment appear to have been fulfilled in so far as it is DESIGN PROFESSIONAL's responsibility to observe the Work.

3. DESIGN PROFESSIONAL's recommendation of any payment, including final payment, shall not mean that DESIGN PROFESSIONAL is responsible for CONTRACTOR's means, methods, techniques, sequence or procedures of construction, safety precautions and programs incident thereto, or any failure of CONTRACTOR to comply with Laws or Regulations applicable to the furnishing or performance of Work.

4. DESIGN PROFESSIONAL may refuse to recommend the whole or any part of any payment if, in DESIGN PROFESSIONAL's opinion, it would be incorrect to make the representations to CITY referred to in Paragraph 14.02 B.2. DESIGN PROFESSIONAL may also refuse to recommend any such payment or, because of subsequently discovered evidence or the results of subsequent inspections or tests, nullify any such payment previously recommended, to such extent as may be necessary in DESIGN PROFESSIONAL's opinion to protect CITY from loss because:

- a. the Work is defective, or completed Work has been damaged requiring correction or replacement;
- b. the Contract Price has been reduced by Written Amendment or Change Orders;
- c. CITY has been required to correct defective Work or complete Work in accordance with Paragraph 13.09; or
- d. DESIGN PROFESSIONAL has actual knowledge of the occurrence of any of the events enumerated in Paragraph 15.02.

### **C. Reduction in Payment**

1. CITY may refuse to make payment of the full amount recommended by DESIGN PROFESSIONAL because:

- a. Claims have been made by third parties against CITY on account of CONTRACTOR's performance or furnishing of the Work; or
- b. Claims have been made by CITY against CONTRACTOR in connection with the Work, except where CONTRACTOR has delivered a specific Bond satisfactory to CITY to secure the satisfaction and discharge of such Claims;
- c. there are other items entitling CITY to a set-off against the amount recommended; or
- d. CITY has actual knowledge of the occurrence of any of the events enumerated in Paragraphs 14.02 B.4.a through c or 15.02 A.1 through 4; but CITY must give CONTRACTOR written notice (with a copy to DESIGN PROFESSIONAL) stating the reasons for such action and promptly pay CONTRACTOR the amount so withheld, or any adjustment thereto agreed to by CITY and CONTRACTOR, when CONTRACTOR corrects to CITY's satisfaction the reasons for such action; or
- e. CITY has made a different determination of the actual quantities and classifications of Unit Price Work.

### **14.03 CONTRACTOR's Warranty of Title**

**A.** CONTRACTOR warrants and guarantees that title to all Work, materials and equipment covered by any Application for Payment, whether incorporated into the Project or not, will pass to CITY no later than the time of payment, free and clear of all Liens.

### **14.04 Substantial Completion**

**A.** When CONTRACTOR considers the entire Work ready for its intended use CONTRACTOR shall notify CITY and DESIGN PROFESSIONAL in writing that the entire Work is substantially complete (except for items specifically listed by CONTRACTOR as incomplete) and request that CITY issue a certificate of Substantial Completion. Within a reasonable time thereafter, CITY, together with CONTRACTOR and DESIGN PROFESSIONAL, shall make an inspection of the Work to determine the status of completion. If DESIGN PROFESSIONAL does not consider the Work substantially complete, DESIGN PROFESSIONAL will notify CONTRACTOR and CITY in writing giving the reasons therefore. If DESIGN PROFESSIONAL considers the Work substantially complete, DESIGN PROFESSIONAL will prepare and deliver to CITY a recommended certificate of Substantial Completion that shall establish the date of Substantial Completion. There shall be attached to the certificate a tentative list of items to be completed or corrected before final payment. CITY shall have seven (7) days after receipt of the recommended certificate during which to make written objection to DESIGN PROFESSIONAL as to any provisions of the certificate or attached list. At the time of delivery of the recommended certificate of Substantial Completion, DESIGN PROFESSIONAL will deliver to CITY and CONTRACTOR a written recommendation as to division of responsibilities pending final payment between CITY and CONTRACTOR with respect to security, operation, safety, protection of the Work, maintenance, heat, utilities, insurance and warranties and guarantees.

**B.** CITY shall have the right to exclude CONTRACTOR from the Site after the date of Substantial Completion, but CITY shall allow CONTRACTOR reasonable access to complete or correct items on the tentative list.

### **14.05 Partial Utilization**

**A.** Use by CITY at CITY's option of any substantially completed part of the Work which has specifically been identified in the Contract Documents, or which CITY, DESIGN PROFESSIONAL and CONTRACTOR agree constitutes a separately functioning and usable part of the Work that can be used by CITY for its intended purpose without significant interference with CONTRACTOR's performance of the remainder of the Work, may be accomplished prior to Substantial Completion of all the Work subject to the following:

1. CITY at any time may request CONTRACTOR in writing to permit CITY to use any such part of the Work which CITY believes to be ready for its intended use and substantially complete. If CONTRACTOR agrees that such part of the Work is substantially complete, CONTRACTOR will certify to CITY and DESIGN PROFESSIONAL that such part of the Work is substantially complete and request CITY to issue a certificate of Substantial Completion for that part of the Work. CONTRACTOR at any time may notify CITY and DESIGN PROFESSIONAL in writing that CONTRACTOR considers any such part of the Work ready for its intended use and substantially complete and request CITY to issue a certificate of Substantial Completion for that part of the Work. Within a reasonable time after either such request, CITY, together with CONTRACTOR and DESIGN PROFESSIONAL, shall make an inspection of that part of the Work to determine its status of completion. If DESIGN PROFESSIONAL does not consider that part of the Work to be substantially complete, DESIGN PROFESSIONAL will notify CITY and CONTRACTOR in writing, giving the reasons therefore. If DESIGN PROFESSIONAL considers that part of the Work to be substantially complete, the provisions of Paragraph 14.04 will apply with respect to certification of Substantial Completion of that part of the Work and the division of responsibility in respect thereof and access thereto.

2. No occupancy or separate operation of part of the Work will be accomplished prior to compliance with the requirements of Paragraph 5.09 with respect to property insurance.

#### **14.06 Final Inspection**

A. Upon written notice from CONTRACTOR that the entire Work or an agreed portion thereof is complete, DESIGN PROFESSIONAL will make a final inspection with CITY and CONTRACTOR and will notify CONTRACTOR in writing of all particulars in which this inspection reveals that the Work is incomplete or defective. CONTRACTOR shall immediately take such measures as are necessary to complete such Work or remedy such deficiencies.

#### **14.07 Final Payment**

##### **A. Application for Payment**

1. After CONTRACTOR has completed all corrections required by Paragraph 14.06 to the satisfaction of DESIGN PROFESSIONAL and CITY's Representative and delivered in accordance with the Contract Documents all maintenance and operating instructions, schedules, guarantees, Bonds, certificates or other evidence of insurance required by Paragraph 5.04, certificates of inspection, marked-up record documents (as provided in Paragraph 6.13) and other documents, CONTRACTOR may make application for final payment following the procedure for progress payments.

2. The final Application for Payment shall be accompanied (except as previously delivered) by:

a. all documentation required by the Contract Documents, including but not limited to the evidence of insurance required by Subparagraph 5.04 B.7; and

b. 01290.14 "Contractor Affidavit for Final Payment" from CONTRACTOR and 01290.15 "Subcontractor Affidavit for Final Payment" from all Subcontractors, regardless of tier.

##### **B. Review of Application and Acceptance**

1. If, on the basis of DESIGN PROFESSIONAL's and CITY's Representative's observation of the Work during construction and final inspection, and DESIGN PROFESSIONAL's and CITY's Representative's review of the final Application for Payment and accompanying documentation as required by the Contract Documents, DESIGN PROFESSIONAL and CITY's Representative are satisfied that the Work has been completed and CONTRACTOR's other obligations under the Contract Documents have been fulfilled, DESIGN PROFESSIONAL will, within ten (10) days after receipt of the final Application for Payment, indicate in writing DESIGN PROFESSIONAL's and CITY's Representative's recommendation of payment and present the Application to CITY for payment. At the same time DESIGN PROFESSIONAL will also give written notice to CITY and CONTRACTOR that the Work is acceptable subject to the provisions of Paragraph 14.09.

2. Otherwise, DESIGN PROFESSIONAL will return the Application to CONTRACTOR, indicating in writing the reasons for refusing to recommend final payment, in which case CONTRACTOR shall make the necessary corrections and resubmit the Application to DESIGN PROFESSIONAL. After the presentation to CITY of the Application and accompanying documentation, in appropriate form and substance, including applicable federal and state prevailing wage provisions, and with DESIGN PROFESSIONAL's recommendation and notice of acceptability, the amount recommended by DESIGN PROFESSIONAL will become due and will be paid by CITY to CONTRACTOR in accordance with Laws and Regulations.

#### **14.08 Final Completion Delayed**

A. If, through no fault of CONTRACTOR, final completion of the Work is significantly delayed and if DESIGN PROFESSIONAL so recommends and CITY concurs, CITY shall, upon

receipt of CONTRACTOR's final Application for Payment and recommendation of DESIGN PROFESSIONAL, and without terminating the Contract, make payment of the balance due for that portion of the Work fully completed and accepted. If the remaining balance to be held by CITY for Work not fully completed or corrected is less than the retainage stipulated in the Supplementary Conditions, and if Bonds have been furnished as required in Paragraph 5.01, the written consent of the surety to the payment of the balance due for that portion of the Work fully completed and accepted shall be submitted by CONTRACTOR to DESIGN PROFESSIONAL with the Application for Payment. Payment shall be made under the terms and conditions governing final payment, except that it shall not constitute a waiver of Claims.

#### **14.09 Waiver of Claims**

**A.** The making and acceptance of final payment will constitute:

1. a waiver of all claims by CITY against CONTRACTOR, except claims previously made in writing and still unsettled, or claims arising from defective Work appearing after final inspection pursuant to Paragraph 14.06, from failure to comply with the Contract Documents or the terms of any special guarantees specified therein, or from CONTRACTOR's continuing obligations under the Contract Documents; and

2. a waiver of all Claims by CONTRACTOR against CITY other than those previously made in writing pursuant to Paragraphs 16.02 and 16.03 and still unsettled.

#### **14.10 Completion of Work by CITY**

**A.** If CITY must complete the Work, all costs and charges incurred by CITY, together with the cost of completing the Work under the Contract, will be deducted from any monies due or which may become due CONTRACTOR. If such expense exceeds the sum which would have been payable under the Contract, then CONTRACTOR and the surety shall be liable and shall pay to CITY the amount of such excess.

### **ARTICLE 15 SUSPENSION OF WORK AND TERMINATION**

#### **15.01 CITY May Suspend Work**

**A.** Notwithstanding any other provision of this Contract, at any time and without cause, and at its sole and absolute discretion, CITY, may suspend the Work or any portion of the Work by written notice to CONTRACTOR, which will initially fix the date on which Work will be resumed. CONTRACTOR shall resume the Work on the date so fixed in the notice unless the date is changed by a subsequent written notice from CITY. CONTRACTOR may be allowed an adjustment in the Contract Price or an extension of the Contract Times, or both, directly attributable to any suspension if CONTRACTOR makes a Claim therefore in accordance with Article 16.

**B.** CONTRACTOR will not be allowed an adjustment in the Contract Price or an extension of the Contract Times if CITY suspends the Work because CONTRACTOR's acts or omissions create or cause an emergency that CITY believes affects the safety or protection of persons, the Work, or property at the Site or adjacent thereto. CITY may order CONTRACTOR to stop the Work, or any portion thereof, until the cause for such order has been adequately addressed by CONTRACTOR; however, this right of CITY to stop the Work shall not give rise to any duty on the part of CITY to exercise this right for the benefit of CONTRACTOR, any Subcontractor, Supplier, other individual or entity or any surety or employee or agent of any of them.

#### **15.02 CITY May Terminate for Default**

**A.** CONTRACTOR may be deemed in default and CITY may terminate the services of CONTRACTOR upon the occurrence of any one or more of the following events:

1. CONTRACTOR fails to perform the Work in accordance with the Contract Documents (including, but not limited to, failure to supply sufficient skilled workers or suitable materials or equipment or failure to adhere to the progress schedule established under Paragraph 2.06 and 2.07 as adjusted from time to time pursuant to Paragraphs 6.04, 6.05, 12.02 and 12.03);

2. CONTRACTOR abandons the Work or declares its intention to abandon the Work;
3. CONTRACTOR assigns or attempts to assign its rights or obligations under this Contract or any part thereof to any third party without the prior written consent of CITY;
4. CONTRACTOR fails to make prompt payment duly owing to any subcontractor for Work completed in accordance to the Contract Documents or material supplier for materials delivered for incorporation into the Work within thirty (30) calendar days after payment was due;
5. CONTRACTOR fails to achieve the required dates of substantial and final completion;
6. CONTRACTOR disregards Laws or Regulations of any public body having jurisdiction;
7. CONTRACTOR disregards the authority of DESIGN PROFESSIONAL or OWNER;  
or
8. CONTRACTOR otherwise violates in any substantial way any provisions of the Contract Documents.

**B.** CITY may, after giving CONTRACTOR (and the surety) seven (7) days written notice and to the extent permitted by Laws or Regulations, terminate the services of CONTRACTOR, exclude CONTRACTOR from the Site and take possession of the Work and of all CONTRACTOR's tools, appliances, construction equipment and machinery at the Site and use the same to the full extent they could be used by CONTRACTOR (without liability to CONTRACTOR for trespass or conversion), incorporate into the Work all materials and equipment stored at the Site or for which CITY has paid CONTRACTOR but which are stored elsewhere, and finish the Work as CITY may deem expedient. In such case, CONTRACTOR shall not be entitled to receive any further payment until the Work is finished. If the unpaid balance of the Contract Price exceeds all costs, losses and damages (including but not limited to all fees and charges of engineers, architects, attorneys, and other professionals and all court or arbitration or other dispute resolution costs) sustained by CITY arising out of or resulting from completing the Work, such excess may be paid to CONTRACTOR. If such costs, losses and damages exceed such unpaid balance, CONTRACTOR shall pay the difference to CITY within fourteen (14) calendar days of CITY'S demand for payment. When exercising any rights or remedies under this Paragraph CITY shall not be required to competitively bid this work unless required by law.

**C.** Where CONTRACTOR's services have been so terminated by CITY, the termination will not affect any rights or remedies of CITY against CONTRACTOR then existing or which may thereafter accrue. Any retention or payment of moneys due CONTRACTOR by CITY will not release CONTRACTOR from liability.

**D.** If, after a default termination, it is determined that the CONTRACTOR was not in default, the rights and obligations of the parties shall be the same as if the termination had been issued for the convenience of the CITY. The CITY shall then be liable to CONTRACTOR for only those costs enumerated in paragraph 15.03.

### **15.03 CITY May Terminate for Convenience**

**A.** Notwithstanding any other provision of this Contract, upon seven (7) calendar days written notice to CONTRACTOR, CITY may, at its sole and absolute discretion, without cause and without prejudice to any other right or remedy of CITY, elect to terminate the Contract. In such case, CONTRACTOR shall, with thirty (30) calendar days of receiving notice of termination under this paragraph, submit to CITY its statement of costs and expenses and shall be paid:

1. for completed and acceptable Work executed in accordance with the Contract Documents prior to the effective date of termination, including fair and reasonable sums for overhead and profit on such Work;



2. for expenses sustained prior to the effective date of termination in performing services and furnishing labor, materials or equipment as required by the Contract Documents in connection with uncompleted Work, plus fair and reasonable sums for overhead and profit on such expenses;

3. for all costs, losses and damages incurred in settlement of terminated contracts with Subcontractors, Suppliers and others; and

4. for reasonable expenses directly attributable to termination if approved in advance by CITY.

**B.** CONTRACTOR shall not be paid on account of loss of anticipated profits or revenue or other economic loss arising out of or resulting from such termination.

**C.** CONTRACTOR waives any costs not submitted to CITY pursuant to paragraph 15.03.A.

**D.** CITY shall, within thirty (30) calendar days after receipt of CONTRACTOR's statement, pay CONTRACTOR all amounts it determines are properly determined.

## **ARTICLE 16 CLAIMS AND DISPUTES**

### **16.01 Definition**

**A.** A Claim is a demand or assertion by the CONTRACTOR seeking, as a matter of right, the adjustment of Contract price and/or times with respect to the terms of the Contract.

### **16.02 Written Notice and Burden of Proof**

**A.** Claims must be made by written notice pursuant to Paragraph 17.01. The written notice shall clearly indicate that the CONTRACTOR is making a claim. The responsibility to substantiate Claims shall rest with the CONTRACTOR. No Claim may be made under this Contract except as provided in this Article.

**B.** Certification of Claim: The written notice of Claim shall include the following statement signed by the CONTRACTOR's representative: "The CONTRACTOR certifies that all statements made and the facts set out in this claim are true and correct and that no false records have been submitted in support of this claim." **Strict compliance with this paragraph shall be a condition precedent to the creation, existence or validity of any Claim.**

### **16.03 Time Limits on Claims**

**A.** The CONTRACTOR must give notice to the CITY within fourteen (14) calendar days after the denial of a request for or failure to reach an agreement on a change in Contract Price and/or change in Contract Time pursuant to Article 11 and Article 12 respectively. After the fourteen (14) day period for making Claims has expired, the Claim shall be considered waived.

**B.** The CONTRACTOR shall submit the Claim to the CITY's Representative.

### **16.04 Continuing Contract Performance**

**A.** Pending final resolution of a Claim, unless otherwise agreed in writing, the CONTRACTOR shall proceed diligently with performance of the Work and the CITY shall continue to make payments in accordance with the Contract Documents. The CITY may, but is not obligated to, notify the Surety of the nature and amount of the Claim.

### **16.05 Injury or Damage to Person or Property**

**A.** If either party to the Contract suffers injury or damage to person or property because of an act or omission of the other party, of any of the other party's employees or agents, or of others for whose acts that party is legally liable, written notice of the injury or damage, whether or not insured, shall be given to the other party within a reasonable time not exceeding thirty (30) days after first observance. The notice shall provide sufficient detail to enable the other party to investigate the matter.

### **16.06 Initial Resolution of Claims and Disputes**

**A.** After the CONTRACTOR has submitted the Claim to the CITY'S Representative, the CITY'S Representative and CONTRACTOR'S Representative shall conduct a settlement conference within fourteen (14) calendar days from the date of receipt of the Claim. If the Claim is not settled within seven (7) calendar days following the date of the settlement conference, the CITY'S Representative and the CONTRACTOR's Representative shall state, in writing, following the conclusion of the seven (7) calendar day period, their respective position as to the matters in dispute.

**B.** The CITY'S and CONTRACTOR'S statement of positions shall state all known factual grounds for each party's position. If the dispute remains unresolved at the end of the seven (7) calendar days from submission of the parties' written position statements, the CONTRACTOR shall have the right to proceed with the pursuit of Claims pursuant to paragraph 16.07.

**C.** If a Claim has been resolved, the OWNER will prepare or obtain appropriate documentation.

#### **16.07 Final Resolution of Claims and Disputes**

**A.** All administrative procedures set forth in this contract must first be exhausted before suit is filed.

**B.** If the CITY'S Representative and the CONTRACTOR'S Representative are unable to resolve the dispute pursuant to 16.06, the parties must submit their statements of position to the Director, who shall review the Claim and make a decision within fourteen (14) calendar days.

**C.** Absent fraud, gross mistake or bad faith, the Director's decision shall be final and binding on CITY and CONTRACTOR within fourteen (14) calendar days after issuance. The CONTRACTOR shall give written notice to the CITY stating its intent to submit its Claim to a court of law pursuant to paragraph 17.05.A. within thirty (30) calendar days after notice of Director's decision.

**D.** The time frames for the Director's decision and for CONTRACTOR'S written notice of intent may be tolled by participation in voluntary mediation. Mediator selection and the procedures to be employed in voluntary mediation shall be mutually acceptable to the parties. Costs of the mediator shall be shared equally among the parties participating in the mediation. In no event shall any time frame be tolled more than 30 days for mediation. However, mediation may be employed at any time at the discretion and mutual agreement of the parties.

**E.** If the dispute is not resolved during voluntary mediation, The CONTRACTOR agrees that it will file no suit based on facts or evidentiary materials that were not presented for consideration to the CITY during the mediation process or of which the CONTRACTOR had knowledge and failed to present during the administrative procedures.

### **ARTICLE 17 MISCELLANEOUS**

#### **17.01 Giving Notice**

**A.** Whenever any provision of the Contract Documents requires the giving of written notice, it will be given by personal delivery, by registered or certified mail, postage prepaid, to the last business address known to the giver of the notice or by confirmed electronic facsimile transmission. Notice is effective on the date of personal delivery, deposit of registered or certified mail, postage prepaid, or confirmed electronic facsimile transmission.

#### **17.02 Computation of Times**

**A.** When any period of time is referred to in the Contract Documents by days, it will be computed to exclude the first and include the last calendar day of such period. If the last day of such period falls on a Saturday or Sunday or on a day made a legal holiday by the law of the applicable jurisdiction, such day will be omitted from the computation.

#### **17.03 Cumulative Remedies**

**A.** The duties and obligations imposed by these General Conditions and the rights and remedies available hereunder to the parties hereto, and, in particular but without limitation, the

warranties, guarantees and obligations imposed upon CONTRACTOR and all of the rights and remedies available to CITY and DESIGN PROFESSIONAL hereunder are in addition to, and are not to be construed in any way as a limitation of, any rights and remedies available to any or all of them which are otherwise imposed or available by Laws or Regulations, by special warranty or guarantee or by other provisions of the Contract Documents, and the provisions of this Paragraph will be as effective as if repeated specifically in the Contract Documents in connection with each particular duty, obligation, right and remedy to which they apply.

#### **17.04 Survival of Obligations**

A. All representations, indemnifications, warranties, and guarantees made in, required by, or given in accordance with the Contract Documents, as well as all continuing obligations indicated in the Contract Documents will survive final payment, completion, and acceptance of the Work or termination or completion of the Contract.

#### **17.05 Controlling Law**

A. This Contract shall be construed and governed in accordance with the laws of the State of Missouri without giving effect to Missouri's choice of law provisions. The CITY and CONTRACTOR: (1) shall submit exclusively to the jurisdiction of the state and federal courts located in Jackson County, Missouri and no other; (2) shall waive any and all objections to jurisdiction and venue; and (3) shall not raise forum non conveniens as an objection to the location of any litigation.



## SUPPLEMENTARY CONDITIONS

Project/Contract Number: 80002486 / 9829

Project Title: Emergency Water Distribution System Repairs

These Supplementary Conditions amend or supplement the General Conditions of the Construction Contract and other provisions of the Contract Documents as indicated below. All provisions that are not so amended or supplemented remain in full force and effect.

**SC-2.03 A.** Article 2, Paragraph 2.03, Copies of Documents, is amended by deleting Paragraph 2.03 A and replacing it with the following:

- A. CITY shall furnish to CONTRACTOR up to one (1) copies of the Drawings and Specifications, including Addenda.

**SC-4.02** Article 4, Paragraph 4.02, Subsurface and Physical Conditions; Subparagraphs A and B are supplemented as follows:

In the preparation of the Contract Documents, **no drawings** of explorations and tests of subsurface conditions at or contiguous to the Site of the Work were utilized.

**SC-4.06** Article 4, Paragraph 4.06, Asbestos, Lead-Based Paint, PCBs, Petroleum Waste or Radioactive Material, Subparagraphs A and B are supplemented as follows:

In the preparation of the Contract Documents, no reports of explorations and tests of any Hazardous Environmental Condition(s) at the Site of the Work were utilized.

**SC- 5.01 A.** Article 5, Paragraph 5.01, Performance, Payment and Other Bonds, Subparagraph A, second sentence, is revised as follows:

These Bonds shall remain in effect at least until 3 **years** after the date when final payment becomes due, except as provided otherwise by Laws or Regulations or by the Contract Documents.

**SC-5.03 A.** Article 5, Paragraph 5.03 Certificates of Insurance, Subparagraph A is amended by adding the following Subparagraph 1:

1. CONTRACTOR shall obtain evidence that all Subcontractors have in force the required coverage in the amounts required by these Contract Documents, and evidence that each is current on its unemployment insurance payments before Subcontractors begin Work at the Site. CONTRACTOR shall retain such evidence in its files and make available to CITY within ten (10) days after written request.

**SC-5.06 A.** Article 5, Paragraph 5.06, Property Insurance, is amended by deleting Subparagraph A and inserting the following:

A. CONTRACTOR shall not be required to purchase and maintain property insurance on the Work at the Site.

**SC-6.06 A.1** Article 6, Paragraph 6.06 Substitutes and "Or-Equal" Items, Paragraph A is amended by adding the following at the end of Paragraph A.1:

Proposed "or-equal" items must be submitted to CITY at least 7 days prior to Bid date at the following address:

4800 E 63<sup>rd</sup> Street  
Kansas City, Missouri 64130  
Attn: Jason Wright, Project Manager

Only Bidders may submit proposed "or-equal" items and such items must require no change in related Work. Acceptance by CITY of any proposed "or-equal" items will be made by Addendum only.

**SC-6.06 A.2.** Article 6, Paragraph 6.06 Substitutes and "Or-Equal" Items, Paragraph A is amended by adding the following at the end of Paragraph A.2:

Proposed substitute items must be submitted to CITY's Representative not later than 7 days prior to the time the item is to be incorporated into the Work. Only CONTRACTOR may submit proposed substitute items, and such items must be submitted to CITY's Representative on the standard City form 01630 - Substitution Request. Acceptance by CITY of any proposed substitute item will be made by Change Order.

**SC-6.10.** Article 6, Paragraph 6.10, Compliance with Laws and Regulations, is amended by adding the following new Subparagraphs immediately following Subparagraph 6.10 I 2:

a. CONTRACTOR will be required to comply with wage rates as follows:

County – Cass, Clay, Jackson and Platte

Work Type: State – Heavy

**SC-6.10.** Article 6, Paragraph 6.10, Compliance with Laws and Regulations, is amended by adding the following new Subparagraph 6.10 S:

1. "Resident Laborers" means laborers who have been residents of the State of Missouri for at least thirty days and who intend to remain Missouri residents, and residents of Nonrestrictive States.

2. "Nonrestrictive States" means states identified by the Missouri Department of Labor and Industrial Relations Division of Labor Standards that have not enacted state laws restricting Missouri laborers from working on public works projects. A list of Nonrestrictive States can be found on the Division web site at <http://www.dolir.mo.gov/ls/index.htm>.

3. A period of Excessive Unemployment is declared when the Missouri Department of Labor and Industrial Relations Division of Labor Standards provides notice of such declaration. When in effect, notice will be provided on the Division web site at <http://www.dolir.mo.gov/ls/index.htm>. It is CONTRACTOR's obligation to determine whether a period of Excessive Unemployment is in effect when this Contract is let.

4. CONTRACTOR agrees to follow the provisions of Section 290.560 - 290.575 RSMo and agrees that if a period of Excessive Unemployment has been declared at any point during the term of this Contract, it will employ and require all Subcontractors of whatever tier to employ only Resident Laborers for the Work to be performed under this CONTRACT. Provided, however, CONTRACTOR may use laborers who are not Resident Laborers when Resident Laborers are not available or are incapable of performing the particular type of work involved if CONTRACTOR so certifies in writing to CITY and CITY issues a written approval. This provision does not apply to regularly employed nonresident executive, supervisory or technical employees.

Article 6, Paragraph 6.10, Compliance with Laws and Regulations, is amended by adding the following new Subparagraph 6.10 T:

Contract Information Management System. CONTRACTOR shall comply with CITY's Contract Information Management System requirements. CONTRACTOR shall use CITY's Internet web based Contract Information Management System/Project Management Communications Tool provided by CITY and protocols included in that software during the term of this Contract. CONTRACTOR shall maintain user applications to CITY's provided system for all personnel, subcontractors or suppliers as applicable.

**SC-6.11.** Article 6, Paragraph 6.11, Taxes, is amended by adding the following sentence to Subparagraph 6.11 B:

B. Tax Compliance. The following subparagraphs apply if the Contract is over \$160,000.00.

**SC-6.21 RESERVED**

**SC-12.01** Article 12, Paragraph 12.01, Time of the Essence is amended by adding the following new Subparagraphs immediately following Subparagraph 12.01 A:

B. Starting and Completion

1. Times stated in the Contract Documents are of the essence of the Contract. CONTRACTOR will likely have to work outside of normal work hours and in unfavorable weather conditions in order to meet these performance requirements. Once the Work starts, CONTRACTOR shall continuously pursue completion of the Work.

2. The Work under this contract will relate to both emergency code 3 repairs as well as other lower-priority work with priority codes 0, 1, and 2. All work orders must be completed within the following completion times. These completion times shall be calculated as the number of days from the date the work order is assigned to CONTRACTOR to the time it is complete.

- Code 3 – 24 hours
- Code 2 – 12 calendar days
- Code 1 – 21 calendar days
- Code 0 – 30 calendar days

C. Liquidated Damages

1. If a work order is not completed within the period stated in Paragraph 12.01 A.2, CONTRACTOR shall pay to CITY the amount of ONE HUNDRED DOLLARS (\$100) as liquidated damages for each Calendar Day, per work order, that is incomplete. A work order is considered complete for the purpose of meeting these performance requirements when the repair has been completed per CITY standards, the site has been backfilled and is ready for restoration, and the CONTRACTOR has provided the required information to close the work order in the CITY's work order system. The amount of liquidated damages shall be deducted from any payments due or to become due to the CONTRACTOR.

2. The CITY may suspend accrual of liquidated damages for delays out of the control of CONTRACTOR if CONTRACTOR can demonstrate such delays per section 12 of Specification 00700, General Conditions. On particularly involved work orders, CONTRACTOR and CITY may negotiate a construction schedule based on the specific work order requirements. Both parties realize that weather conditions may impede the

schedule of some construction work. CONTRACTOR shall strive to meet these performance criteria in spite of normal year-round weather conditions. The CITY may suspend accrual of liquidated damages for an extended period of extreme weather. If an extended period of extreme weather is encountered, it shall be the responsibility of CONTRACTOR to demonstrate that additional completion time should be awarded as per Specification 00700, General Conditions.

Whether or not any liquidated damages are assessed and the amount thereof shall be based on a review of Work Orders and other required documentation. As part of the payment application, the CONTRACTOR shall provide a detailed listing of work orders completed during the month including the work order number, address, cost, date assigned, and date completed in Microsoft Excel format. Work Orders shall be invoiced in the next pay application following their completion. If any given work order is rejected by CITY because it does not meet the requirements of these contract specifications, it will not be considered complete until it has been corrected and accepted by CITY.

**SC-13.07** Article 13, Paragraph 13.07, Correction Period, Subparagraph A is amended as follows:

The correction period set forth in Paragraph 13.07 A shall be three (3) years instead of one (1) year, which longer period of time shall also be applicable to the correction period set forth in Paragraph 13.07 C. All other provisions of Paragraph 13.07 remain unchanged except as necessary to accommodate the revised length of the correction period.

**SC-14.02 A.** Article 14, Paragraph 14.02, Application for Progress Payments, Subparagraph A is amended by deleting Item 3 and adding the following:

3. CITY shall make payments to CONTRACTOR monthly on or about the 15th day of each month. Payments to CONTRACTOR will be made on the basis of ninety-five percent (95%) of the value of the Work satisfactorily completed plus ninety-five percent (95%) of the value of properly stored and insured, unused materials on hand on the Site of the Work. CITY shall retain five percent (5%) of each partial payment until completion and acceptance of the Work covered by the Contract and final payment is due. All Work covered by a payment becomes CITY's property, provided that the Work paid for remains the sole responsibility of CONTRACTOR until all terms and conditions of the Contract have been met.

**SC-14.05** Article 14, Paragraph 14.05, Partial Utilization is amended by adding the following new Subparagraph A.3. immediately following Subparagraph 14.05 A.2:

3. CITY at any time may make a written request to CONTRACTOR to permit CITY to take over operation of any part of the Work although it is not substantially complete. A copy of the request will be sent to DESIGN PROFESSIONAL, and within a reasonable time thereafter CITY, CONTRACTOR and DESIGN PROFESSIONAL shall make an inspection of that part of the Work to determine its status of completion and will prepare a list of the items remaining to be completed or corrected thereon before final payment. If CONTRACTOR does not make written objection to CITY and DESIGN PROFESSIONAL that such part of the Work is not ready for separate operation by CITY, DESIGN PROFESSIONAL will finalize the list of items to be completed or corrected and will deliver such lists to CITY and CONTRACTOR. DESIGN PROFESSIONAL will also make a written recommendation as to the division of responsibilities pending final payment between CITY and CONTRACTOR with respect to security, operation, safety, maintenance, utilities, insurance, warranties and guarantees for that part of the Work, which recommendation will become binding upon CITY and CONTRACTOR at the time when CITY takes over such operation (unless

they shall have otherwise agreed in writing and so informed DESIGN PROFESSIONAL). During such operation and prior to Substantial Completion of such part of the Work, CITY shall allow CONTRACTOR reasonable access to complete or correct items on said list and to complete other related Work.

**SC-17.06** The CONTRACTOR agrees to enter into up to One (1) successive \$2,700,000.00 renewals to this Contract if so requested by the CITY. The determination to renew the Contract will be at the sole discretion of the CITY where such renewal would be in the best interest of the CITY. Upon renewal of the contract, an increase in a Unit Price, if any, will be determined solely by the CITY, and if needed, will not exceed the change in the Consumer Price Index for the period since the Contract or last Renewal was signed. The US All City Average Consumer Price Index – All Urban Consumers (CPI-U) (seasonally adjusted, all items, and current base) will be used. The values used to calculate the maximum potential percent increase will be the value from the month the Contract is executed to the most current monthly value available at the time the Contract is renewed. Values will be from the web site for the Bureau of Labor Statistics, Consumer Price Index.



## SECTION 00830

### PREVAILING WAGE

1. Annual Wage Order No. 31
2. **0830.03 Division of Labor Standards Rules & Regulations** are incorporated into and made part of this Contract and are available at <http://s1.sos.mo.gov/cmsimages/adrules/csr/current/8csr/8c30-3.pdf>.

# Missouri

## Division of Labor Standards

### WAGE AND HOUR SECTION

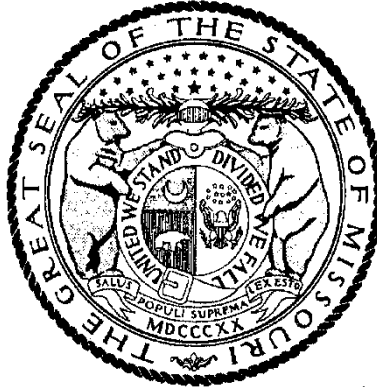

MICHAEL L. PARSON, Governor

# Annual Wage Order No. 31

Section 019  
**CASS COUNTY**

In accordance with Section 290.262 RSMo 2000, within thirty (30) days after a certified copy of this Annual Wage Order has been filed with the Secretary of State as indicated below, any person who may be affected by this Annual Wage Order may object by filing an objection in triplicate with the Labor and Industrial Relations Commission, P.O. Box 599, Jefferson City, MO 65102-0599. Such objections must set forth in writing the specific grounds of objection. Each objection shall certify that a copy has been furnished to the Division of Labor Standards, P.O. Box 449, Jefferson City, MO 65102-0449 pursuant to 8 CSR 20-5.010(1). A certified copy of the Annual Wage Order has been filed with the Secretary of State of Missouri.

Original Signed by \_\_\_\_\_

Todd Smith, Director  
Division of Labor Standards

Filed With Secretary of State: \_\_\_\_\_ **March 8, 2024**

Last Date Objections May Be Filed: **April 8, 2024**

Prepared by Missouri Department of Labor and Industrial Relations

Building Construction Rates for  
CASS County

Section 019

OCCUPATIONAL TITLE	**Prevailing Hourly Rate
Asbestos Worker	\$69.76
Boilermaker	\$27.07*
Bricklayer-Stone Mason	\$62.58
Carpenter	\$65.51
Lather	
Linoleum Layer	
Millwright	
Pile Driver	
Cement Mason	\$27.07*
Plasterer	
Communication Technician	\$60.00
Electrician (Inside Wireman)	\$70.56
Electrician Outside Lineman	\$27.07*
Lineman Operator	
Lineman - Tree Trimmer	
Groundman	
Groundman - Tree Trimmer	
Elevator Constructor	\$27.07*
Glazier	\$27.07*
Ironworker	\$69.62
Laborer	\$53.58
General Laborer	
First Semi-Skilled	
Second Semi-Skilled	
Mason	\$27.07*
Marble Mason	
Marble Finisher	
Terrazzo Worker	
Terrazzo Finisher	
Tile Setter	
Tile Finisher	
Operating Engineer	\$63.62
Group I	
Group II	
Group III	
Group III-A	
Group IV	
Group V	
Painter	\$27.07*
Plumber	\$79.79
Pipe Fitter	
Roofer	\$60.03
Sheet Metal Worker	\$76.56
Sprinkler Fitter	\$27.07*
Truck Driver	\$27.07*
Truck Control Service Driver	
Group I	
Group II	
Group III	
Group IV	

\*The Division of Labor Standards received fewer than 1,000 reportable hours for this occupational title. The public works contracting minimum wage is established for this occupational title using data provided by Missouri Economic Research and Information Center.

\*\*The Prevailing Hourly Rate includes any applicable fringe benefit amounts for each occupational title as defined in RSMo Section 290.210.

Heavy Construction Rates for  
CASS County

Section 019

OCCUPATIONAL TITLE	**Prevailing Hourly Rate
Carpenter	\$27.07*
Millwright	
Pile Driver	
Electrician (Outside Lineman)	\$27.07*
Lineman Operator	
Lineman - Tree Trimmer	
Groundman	
Groundman - Tree Trimmer	
Laborer	\$51.69
General Laborer	
Skilled Laborer	
Operating Engineer	\$59.65
Group I	
Group II	
Group III	
Group IV	
Truck Driver	\$27.07*
Truck Control Service Driver	
Group I	
Group II	
Group III	
Group IV	

Use Heavy Construction Rates on Highway and Heavy construction in accordance with the classifications of construction work established in 8 CSR 30-3.040(3).

Use Building Construction Rates on Building construction in accordance with the classifications of construction work established in 8 CSR 30-3.040(2).

If a worker is performing work on a heavy construction project within an occupational title that is not listed on the Heavy Construction Rate Sheet, use the rate for that occupational title as shown on the Building Construction Rate Sheet.

\*The Division of Labor Standards received fewer than 1,000 reportable hours for this occupational title. Public works contracting minimum wage is established for this occupational title using data provided by Missouri Economic Research and Information Center.

\*\*The Prevailing Hourly Rate includes any applicable fringe benefit amounts for each occupational title.

# OVERTIME and HOLIDAYS

## OVERTIME

For all work performed on a Sunday or a holiday, not less than twice (2x) the prevailing hourly rate of wages for work of a similar character in the locality in which the work is performed or the public works contracting minimum wage, whichever is applicable, shall be paid to all workers employed by or on behalf of any public body engaged in the construction of public works, exclusive of maintenance work.

For all overtime work performed, not less than one and one-half (1½) the prevailing hourly rate of wages for work of a similar character in the locality in which the work is performed or the public works contracting minimum wage, whichever is applicable, shall be paid to all workers employed by or on behalf of any public body engaged in the construction of public works, exclusive of maintenance work or contractual obligation. For purposes of this subdivision, "**overtime work**" shall include work that exceeds ten hours in one day and work in excess of forty hours in one calendar week; and

A thirty-minute lunch period on each calendar day shall be allowed for each worker on a public works project, provided that such time shall not be considered as time worked.

## HOLIDAYS

January first;  
The last Monday in May;  
July fourth;  
The first Monday in September;  
November eleventh;  
The fourth Thursday in November; and  
December twenty-fifth;

If any holiday falls on a Sunday, the following Monday shall be considered a holiday.

# Missouri

## Division of Labor Standards

### WAGE AND HOUR SECTION

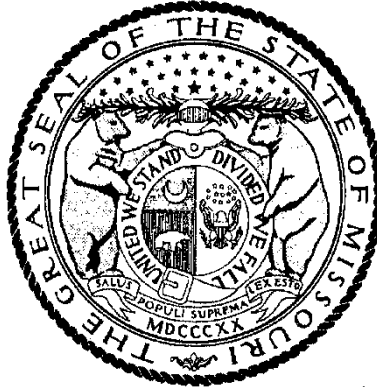

MICHAEL L. PARSON, Governor

## Annual Wage Order No. 31

Section 024  
**CLAY COUNTY**

In accordance with Section 290.262 RSMo 2000, within thirty (30) days after a certified copy of this Annual Wage Order has been filed with the Secretary of State as indicated below, any person who may be affected by this Annual Wage Order may object by filing an objection in triplicate with the Labor and Industrial Relations Commission, P.O. Box 599, Jefferson City, MO 65102-0599. Such objections must set forth in writing the specific grounds of objection. Each objection shall certify that a copy has been furnished to the Division of Labor Standards, P.O. Box 449, Jefferson City, MO 65102-0449 pursuant to 8 CSR 20-5.010(1). A certified copy of the Annual Wage Order has been filed with the Secretary of State of Missouri.

Original Signed by \_\_\_\_\_

Todd Smith, Director  
Division of Labor Standards

Filed With Secretary of State: \_\_\_\_\_ **March 8, 2024**

Last Date Objections May Be Filed: **April 8, 2024**

Prepared by Missouri Department of Labor and Industrial Relations

Building Construction Rates for  
CLAY County

Section 024

OCCUPATIONAL TITLE	**Prevailing Hourly Rate
Asbestos Worker	\$70.59
Boilermaker	\$35.51*
Bricklayer-Stone Mason	\$62.37
Carpenter	\$64.44
Lather	
Linoleum Layer	
Millwright	
Pile Driver	
Cement Mason	\$56.58
Plasterer	
Communication Technician	\$61.30
Electrician (Inside Wireman)	\$68.72
Electrician Outside Lineman	\$35.51*
Lineman Operator	
Lineman - Tree Trimmer	
Groundman	
Groundman - Tree Trimmer	
Elevator Constructor	\$35.51*
Glazier	\$58.94
Ironworker	\$69.61
Laborer	\$50.47
General Laborer	
First Semi-Skilled	
Second Semi-Skilled	
Mason	\$56.70
Marble Mason	
Marble Finisher	
Terrazzo Worker	
Terrazzo Finisher	
Tile Setter	
Tile Finisher	
Operating Engineer	\$63.28
Group I	
Group II	
Group III	
Group III-A	
Group IV	
Group V	
Painter	\$56.98
Plumber	\$78.98
Pipe Fitter	
Roofer	\$59.93
Sheet Metal Worker	\$75.64
Sprinkler Fitter	\$71.38
Truck Driver	\$56.61
Truck Control Service Driver	
Group I	
Group II	
Group III	
Group IV	

\*The Division of Labor Standards received fewer than 1,000 reportable hours for this occupational title. The public works contracting minimum wage is established for this occupational title using data provided by Missouri Economic Research and Information Center.

\*\*The Prevailing Hourly Rate includes any applicable fringe benefit amounts for each occupational title as defined in RSMo Section 290.210.

Heavy Construction Rates for  
CLAY County

Section 024

OCCUPATIONAL TITLE	**Prevailing Hourly Rate
Carpenter	\$64.52
Millwright	
Pile Driver	
Electrician (Outside Lineman)	\$35.51*
Lineman Operator	
Lineman - Tree Trimmer	
Groundman	
Groundman - Tree Trimmer	
Laborer	\$51.51
General Laborer	
Skilled Laborer	
Operating Engineer	\$55.82
Group I	
Group II	
Group III	
Group IV	
Truck Driver	\$51.36
Truck Control Service Driver	
Group I	
Group II	
Group III	
Group IV	

Use Heavy Construction Rates on Highway and Heavy construction in accordance with the classifications of construction work established in 8 CSR 30-3.040(3).

Use Building Construction Rates on Building construction in accordance with the classifications of construction work established in 8 CSR 30-3.040(2).

If a worker is performing work on a heavy construction project within an occupational title that is not listed on the Heavy Construction Rate Sheet, use the rate for that occupational title as shown on the Building Construction Rate Sheet.

\*The Division of Labor Standards received fewer than 1,000 reportable hours for this occupational title. Public works contracting minimum wage is established for this occupational title using data provided by Missouri Economic Research and Information Center.

\*\*The Prevailing Hourly Rate includes any applicable fringe benefit amounts for each occupational title.



# OVERTIME and HOLIDAYS

## OVERTIME

For all work performed on a Sunday or a holiday, not less than twice (2x) the prevailing hourly rate of wages for work of a similar character in the locality in which the work is performed or the public works contracting minimum wage, whichever is applicable, shall be paid to all workers employed by or on behalf of any public body engaged in the construction of public works, exclusive of maintenance work.

For all overtime work performed, not less than one and one-half (1½) the prevailing hourly rate of wages for work of a similar character in the locality in which the work is performed or the public works contracting minimum wage, whichever is applicable, shall be paid to all workers employed by or on behalf of any public body engaged in the construction of public works, exclusive of maintenance work or contractual obligation. For purposes of this subdivision, "**overtime work**" shall include work that exceeds ten hours in one day and work in excess of forty hours in one calendar week; and

A thirty-minute lunch period on each calendar day shall be allowed for each worker on a public works project, provided that such time shall not be considered as time worked.

## HOLIDAYS

January first;  
The last Monday in May;  
July fourth;  
The first Monday in September;  
November eleventh;  
The fourth Thursday in November; and  
December twenty-fifth;

If any holiday falls on a Sunday, the following Monday shall be considered a holiday.

# Missouri

## Division of Labor Standards

### WAGE AND HOUR SECTION

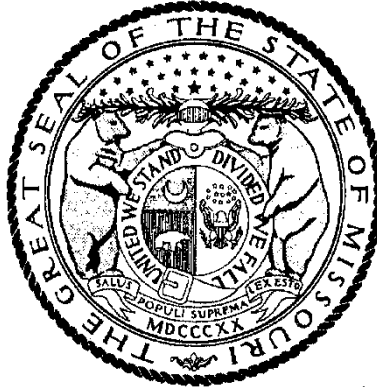

MICHAEL L. PARSON, Governor

# Annual Wage Order No. 31

Section 048  
**JACKSON COUNTY**

In accordance with Section 290.262 RSMo 2000, within thirty (30) days after a certified copy of this Annual Wage Order has been filed with the Secretary of State as indicated below, any person who may be affected by this Annual Wage Order may object by filing an objection in triplicate with the Labor and Industrial Relations Commission, P.O. Box 599, Jefferson City, MO 65102-0599. Such objections must set forth in writing the specific grounds of objection. Each objection shall certify that a copy has been furnished to the Division of Labor Standards, P.O. Box 449, Jefferson City, MO 65102-0449 pursuant to 8 CSR 20-5.010(1). A certified copy of the Annual Wage Order has been filed with the Secretary of State of Missouri.

Original Signed by \_\_\_\_\_

Todd Smith, Director  
Division of Labor Standards

Filed With Secretary of State: \_\_\_\_\_ **March 8, 2024**

Last Date Objections May Be Filed: **April 8, 2024**

Prepared by Missouri Department of Labor and Industrial Relations

OCCUPATIONAL TITLE	**Prevailing Hourly Rate
Asbestos Worker	\$69.50
Boilermaker	\$39.44*
Bricklayer-Stone Mason	\$62.06
Carpenter	\$64.94
Lather	
Linoleum Layer	
Millwright	
Pile Driver	
Cement Mason	\$58.02
Plasterer	
Communication Technician	\$62.38
Electrician (Inside Wireman)	\$70.32
Electrician Outside Lineman	\$61.40
Lineman Operator	
Lineman - Tree Trimmer	
Groundman	
Groundman - Tree Trimmer	
Elevator Constructor	\$93.11
Glazier	\$59.07
Ironworker	\$70.66
Laborer	\$52.42
General Laborer	
First Semi-Skilled	
Second Semi-Skilled	
Mason	\$50.24
Marble Mason	
Marble Finisher	
Terrazzo Worker	
Terrazzo Finisher	
Tile Setter	
Tile Finisher	
Operating Engineer	\$66.05
Group I	
Group II	
Group III	
Group III-A	
Group IV	
Group V	
Painter	\$54.25
Plumber	\$78.88
Pipe Fitter	
Roofer	\$60.69
Sheet Metal Worker	\$76.38
Sprinkler Fitter	\$69.92
Truck Driver	\$54.27
Truck Control Service Driver	
Group I	
Group II	
Group III	
Group IV	

\*The Division of Labor Standards received fewer than 1,000 reportable hours for this occupational title. The public works contracting minimum wage is established for this occupational title using data provided by Missouri Economic Research and Information Center.

\*\*The Prevailing Hourly Rate includes any applicable fringe benefit amounts for each occupational title as defined in RSMo Section 290.210.

Heavy Construction Rates for  
JACKSON County

Section 048

OCCUPATIONAL TITLE	**Prevailing Hourly Rate
Carpenter	\$65.11
Millwright	
Pile Driver	
Electrician (Outside Lineman)	\$90.71
Lineman Operator	
Lineman - Tree Trimmer	
Groundman	
Groundman - Tree Trimmer	
Laborer	\$51.85
General Laborer	
Skilled Laborer	
Operating Engineer	\$60.48
Group I	
Group II	
Group III	
Group IV	
Truck Driver	\$53.04
Truck Control Service Driver	
Group I	
Group II	
Group III	
Group IV	

Use Heavy Construction Rates on Highway and Heavy construction in accordance with the classifications of construction work established in 8 CSR 30-3.040(3).

Use Building Construction Rates on Building construction in accordance with the classifications of construction work established in 8 CSR 30-3.040(2).

If a worker is performing work on a heavy construction project within an occupational title that is not listed on the Heavy Construction Rate Sheet, use the rate for that occupational title as shown on the Building Construction Rate Sheet.

\*The Division of Labor Standards received fewer than 1,000 reportable hours for this occupational title. Public works contracting minimum wage is established for this occupational title using data provided by Missouri Economic Research and Information Center.

\*\*The Prevailing Hourly Rate includes any applicable fringe benefit amounts for each occupational title.

# OVERTIME and HOLIDAYS

## OVERTIME

For all work performed on a Sunday or a holiday, not less than twice (2x) the prevailing hourly rate of wages for work of a similar character in the locality in which the work is performed or the public works contracting minimum wage, whichever is applicable, shall be paid to all workers employed by or on behalf of any public body engaged in the construction of public works, exclusive of maintenance work.

For all overtime work performed, not less than one and one-half (1½) the prevailing hourly rate of wages for work of a similar character in the locality in which the work is performed or the public works contracting minimum wage, whichever is applicable, shall be paid to all workers employed by or on behalf of any public body engaged in the construction of public works, exclusive of maintenance work or contractual obligation. For purposes of this subdivision, "**overtime work**" shall include work that exceeds ten hours in one day and work in excess of forty hours in one calendar week; and

A thirty-minute lunch period on each calendar day shall be allowed for each worker on a public works project, provided that such time shall not be considered as time worked.

## HOLIDAYS

January first;  
The last Monday in May;  
July fourth;  
The first Monday in September;  
November eleventh;  
The fourth Thursday in November; and  
December twenty-fifth;

If any holiday falls on a Sunday, the following Monday shall be considered a holiday.

# Missouri

## Division of Labor Standards

### WAGE AND HOUR SECTION

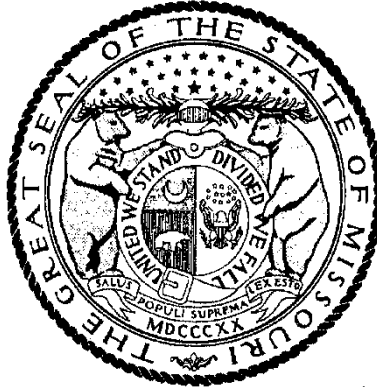

MICHAEL L. PARSON, Governor

# Annual Wage Order No. 31

Section 083  
**PLATTE COUNTY**

In accordance with Section 290.262 RSMo 2000, within thirty (30) days after a certified copy of this Annual Wage Order has been filed with the Secretary of State as indicated below, any person who may be affected by this Annual Wage Order may object by filing an objection in triplicate with the Labor and Industrial Relations Commission, P.O. Box 599, Jefferson City, MO 65102-0599. Such objections must set forth in writing the specific grounds of objection. Each objection shall certify that a copy has been furnished to the Division of Labor Standards, P.O. Box 449, Jefferson City, MO 65102-0449 pursuant to 8 CSR 20-5.010(1). A certified copy of the Annual Wage Order has been filed with the Secretary of State of Missouri.

Original Signed by \_\_\_\_\_

Todd Smith, Director  
Division of Labor Standards

Filed With Secretary of State: \_\_\_\_\_ **March 8, 2024**

Last Date Objections May Be Filed: **April 8, 2024**

Prepared by Missouri Department of Labor and Industrial Relations

Building Construction Rates for  
PLATTE County

Section 083

OCCUPATIONAL TITLE	**Prevailing Hourly Rate
Asbestos Worker	\$70.89
Boilermaker	\$33.79*
Bricklayer-Stone Mason	\$62.40
Carpenter	\$64.93
Lather	
Linoleum Layer	
Millwright	
Pile Driver	
Cement Mason	\$33.79*
Plasterer	
Communication Technician	\$65.26
Electrician (Inside Wireman)	\$70.09
Electrician Outside Lineman	\$33.79*
Lineman Operator	
Lineman - Tree Trimmer	
Groundman	
Groundman - Tree Trimmer	
Elevator Constructor	\$33.79*
Glazier	\$33.79*
Ironworker	\$69.26
Laborer	\$47.89
General Laborer	
First Semi-Skilled	
Second Semi-Skilled	
Mason	\$53.08
Marble Mason	
Marble Finisher	
Terrazzo Worker	
Terrazzo Finisher	
Tile Setter	
Tile Finisher	
Operating Engineer	\$63.82
Group I	
Group II	
Group III	
Group III-A	
Group IV	
Group V	
Painter	\$33.79*
Plumber	\$77.57
Pipe Fitter	
Roofer	\$60.39
Sheet Metal Worker	\$75.86
Sprinkler Fitter	\$33.79*
Truck Driver	\$33.79*
Truck Control Service Driver	
Group I	
Group II	
Group III	
Group IV	

\*The Division of Labor Standards received fewer than 1,000 reportable hours for this occupational title. The public works contracting minimum wage is established for this occupational title using data provided by Missouri Economic Research and Information Center.

\*\*The Prevailing Hourly Rate includes any applicable fringe benefit amounts for each occupational title as defined in RSMo Section 290.210.

Heavy Construction Rates for  
PLATTE County

Section 083

OCCUPATIONAL TITLE	**Prevailing Hourly Rate
Carpenter	\$33.79*
Millwright	
Pile Driver	
Electrician (Outside Lineman)	\$33.79*
Lineman Operator	
Lineman - Tree Trimmer	
Groundman	
Groundman - Tree Trimmer	
Laborer	\$51.05
General Laborer	
Skilled Laborer	
Operating Engineer	\$60.01
Group I	
Group II	
Group III	
Group IV	
Truck Driver	\$53.04
Truck Control Service Driver	
Group I	
Group II	
Group III	
Group IV	

Use Heavy Construction Rates on Highway and Heavy construction in accordance with the classifications of construction work established in 8 CSR 30-3.040(3).

Use Building Construction Rates on Building construction in accordance with the classifications of construction work established in 8 CSR 30-3.040(2).

If a worker is performing work on a heavy construction project within an occupational title that is not listed on the Heavy Construction Rate Sheet, use the rate for that occupational title as shown on the Building Construction Rate Sheet.

\*The Division of Labor Standards received fewer than 1,000 reportable hours for this occupational title. Public works contracting minimum wage is established for this occupational title using data provided by Missouri Economic Research and Information Center.

\*\*The Prevailing Hourly Rate includes any applicable fringe benefit amounts for each occupational title.



# OVERTIME and HOLIDAYS

## OVERTIME

For all work performed on a Sunday or a holiday, not less than twice (2x) the prevailing hourly rate of wages for work of a similar character in the locality in which the work is performed or the public works contracting minimum wage, whichever is applicable, shall be paid to all workers employed by or on behalf of any public body engaged in the construction of public works, exclusive of maintenance work.

For all overtime work performed, not less than one and one-half (1½) the prevailing hourly rate of wages for work of a similar character in the locality in which the work is performed or the public works contracting minimum wage, whichever is applicable, shall be paid to all workers employed by or on behalf of any public body engaged in the construction of public works, exclusive of maintenance work or contractual obligation. For purposes of this subdivision, "**overtime work**" shall include work that exceeds ten hours in one day and work in excess of forty hours in one calendar week; and

A thirty-minute lunch period on each calendar day shall be allowed for each worker on a public works project, provided that such time shall not be considered as time worked.

## HOLIDAYS

January first;  
The last Monday in May;  
July fourth;  
The first Monday in September;  
November eleventh;  
The fourth Thursday in November; and  
December twenty-fifth;

If any holiday falls on a Sunday, the following Monday shall be considered a holiday.

# Missouri

## Division of Labor Standards

### WAGE AND HOUR SECTION

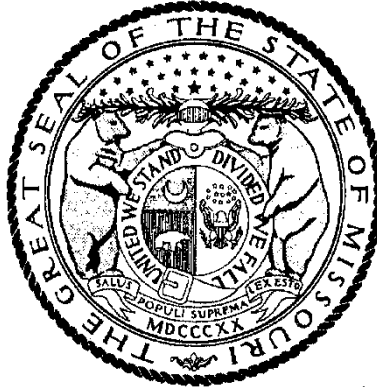

MICHAEL L. PARSON, Governor

# Annual Wage Order No. 31

Section 089  
**RAY COUNTY**

In accordance with Section 290.262 RSMo 2000, within thirty (30) days after a certified copy of this Annual Wage Order has been filed with the Secretary of State as indicated below, any person who may be affected by this Annual Wage Order may object by filing an objection in triplicate with the Labor and Industrial Relations Commission, P.O. Box 599, Jefferson City, MO 65102-0599. Such objections must set forth in writing the specific grounds of objection. Each objection shall certify that a copy has been furnished to the Division of Labor Standards, P.O. Box 449, Jefferson City, MO 65102-0449 pursuant to 8 CSR 20-5.010(1). A certified copy of the Annual Wage Order has been filed with the Secretary of State of Missouri.

Original Signed by \_\_\_\_\_

Todd Smith, Director  
Division of Labor Standards

Filed With Secretary of State: \_\_\_\_\_ **March 8, 2024**

Last Date Objections May Be Filed: **April 8, 2024**

Prepared by Missouri Department of Labor and Industrial Relations

Building Construction Rates for  
RAY County

Section 089

OCCUPATIONAL TITLE	**Prevailing Hourly Rate
Asbestos Worker	\$25.52*
Boilermaker	\$25.52*
Bricklayer-Stone Mason	\$25.52*
Carpenter	\$64.15
Lather	
Linoleum Layer	
Millwright	
Pile Driver	
Cement Mason	\$25.52*
Plasterer	
Communication Technician	\$25.52*
Electrician (Inside Wireman)	\$69.12
Electrician Outside Lineman	\$25.52*
Lineman Operator	
Lineman - Tree Trimmer	
Groundman	
Groundman - Tree Trimmer	
Elevator Constructor	\$25.52*
Glazier	\$25.52*
Ironworker	\$25.52*
Laborer	\$25.52*
General Laborer	
First Semi-Skilled	
Second Semi-Skilled	
Mason	\$25.52*
Marble Mason	
Marble Finisher	
Terrazzo Worker	
Terrazzo Finisher	
Tile Setter	
Tile Finisher	
Operating Engineer	\$25.52*
Group I	
Group II	
Group III	
Group III-A	
Group IV	
Group V	
Painter	\$25.52*
Plumber	\$25.52*
Pipe Fitter	
Roofer	\$25.52*
Sheet Metal Worker	\$25.52*
Sprinkler Fitter	\$25.52*
Truck Driver	\$25.52*
Truck Control Service Driver	
Group I	
Group II	
Group III	
Group IV	

\*The Division of Labor Standards received fewer than 1,000 reportable hours for this occupational title. The public works contracting minimum wage is established for this occupational title using data provided by Missouri Economic Research and Information Center.

\*\*The Prevailing Hourly Rate includes any applicable fringe benefit amounts for each occupational title as defined in RSMo Section 290.210.

Heavy Construction Rates for  
RAY County

Section 089

OCCUPATIONAL TITLE	**Prevailing Hourly Rate
Carpenter	\$25.52*
Millwright	
Pile Driver	
Electrician (Outside Lineman)	\$25.52*
Lineman Operator	
Lineman - Tree Trimmer	
Groundman	
Groundman - Tree Trimmer	
Laborer	\$43.07
General Laborer	
Skilled Laborer	
Operating Engineer	\$48.54
Group I	
Group II	
Group III	
Group IV	
Truck Driver	\$37.09
Truck Control Service Driver	
Group I	
Group II	
Group III	
Group IV	

Use Heavy Construction Rates on Highway and Heavy construction in accordance with the classifications of construction work established in 8 CSR 30-3.040(3).

Use Building Construction Rates on Building construction in accordance with the classifications of construction work established in 8 CSR 30-3.040(2).

If a worker is performing work on a heavy construction project within an occupational title that is not listed on the Heavy Construction Rate Sheet, use the rate for that occupational title as shown on the Building Construction Rate Sheet.

\*The Division of Labor Standards received fewer than 1,000 reportable hours for this occupational title. Public works contracting minimum wage is established for this occupational title using data provided by Missouri Economic Research and Information Center.

\*\*The Prevailing Hourly Rate includes any applicable fringe benefit amounts for each occupational title.

# OVERTIME and HOLIDAYS

## OVERTIME

For all work performed on a Sunday or a holiday, not less than twice (2x) the prevailing hourly rate of wages for work of a similar character in the locality in which the work is performed or the public works contracting minimum wage, whichever is applicable, shall be paid to all workers employed by or on behalf of any public body engaged in the construction of public works, exclusive of maintenance work.

For all overtime work performed, not less than one and one-half (1½) the prevailing hourly rate of wages for work of a similar character in the locality in which the work is performed or the public works contracting minimum wage, whichever is applicable, shall be paid to all workers employed by or on behalf of any public body engaged in the construction of public works, exclusive of maintenance work or contractual obligation. For purposes of this subdivision, "**overtime work**" shall include work that exceeds ten hours in one day and work in excess of forty hours in one calendar week; and

A thirty-minute lunch period on each calendar day shall be allowed for each worker on a public works project, provided that such time shall not be considered as time worked.

## HOLIDAYS

January first;  
The last Monday in May;  
July fourth;  
The first Monday in September;  
November eleventh;  
The fourth Thursday in November; and  
December twenty-fifth;

If any holiday falls on a Sunday, the following Monday shall be considered a holiday.

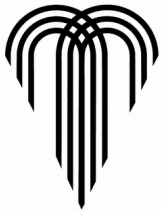

# REQUEST FOR INTERPRETATION

Project Number \_\_\_\_\_

Project Title \_\_\_\_\_

Contractor \_\_\_\_\_

RFI Number \_\_\_\_\_ Date \_\_\_\_\_

From: \_\_\_\_\_

To: \_\_\_\_\_

Re: \_\_\_\_\_

Spec. Sec. Ref: \_\_\_\_\_ Paragraph: \_\_\_\_\_ Drawing Ref: \_\_\_\_\_ Detail: \_\_\_\_\_

Signed: \_\_\_\_\_

Response: \_\_\_\_\_

\_\_\_\_\_  
\_\_\_\_\_  
\_\_\_\_\_  
\_\_\_\_\_  
\_\_\_\_\_  
\_\_\_\_\_  
\_\_\_\_\_  
\_\_\_\_\_  
\_\_\_\_\_  
\_\_\_\_\_

Attachments

Response From: \_\_\_\_\_ To: \_\_\_\_\_ Date Transmitted: \_\_\_\_\_ Date Rec'd: \_\_\_\_\_

Signed: \_\_\_\_\_  
Design Professional

Signed: \_\_\_\_\_  
Owner's Representative

- Distribution:
- Owner
  - Contractor
  - Construction Manager
  - Design Professional
  - Consultant \_\_\_\_\_
  - Other \_\_\_\_\_





## SUPPLEMENTAL DESIGN INSTRUCTION

Project Number \_\_\_\_\_

Project Title \_\_\_\_\_

To Contractor \_\_\_\_\_

From: \_\_\_\_\_ SDI No \_\_\_\_\_ Issue Date: \_\_\_\_\_

---

The Work shall be carried out in accordance with the following supplemental instructions issued in accordance with the Contract Documents without change in Contract Price or Contract Times. Proceeding with the Work in accordance with these instructions indicates your acknowledgement that there will be no change in the Contract Price or Contract Times.

---

Description:

Attachments (*List*)

---

(Signature) Design Professional

Date

---

- Distribution:
- Owner
  - Contractor
  - Construction Manager
  - Design Professional
  - Consultant \_\_\_\_\_
  - Other \_\_\_\_\_





## REQUEST FOR PROPOSAL

Project Number \_\_\_\_\_

Project Title \_\_\_\_\_

To Contractor \_\_\_\_\_

From: \_\_\_\_\_ RFP No \_\_\_\_\_ Issue Date: \_\_\_\_\_

---

Please submit an itemized proposal for changes in the Contract Price and Contract Times for proposed modifications to the Contract Documents described herein. Submit proposal within \_\_\_\_\_ days, or notify the Owner in writing of the date on which you anticipate submitting your proposal.

This is NOT a Change Order, a Work Change Directive or a direction to proceed with the work described in the proposed modifications.

---

Description:

Attachments

---

Prepared by Design Professional

---

Prepared by Construction Manager

---

REQUESTED by OWNER'S Representative

---

Distribution:  Owner  
 Contractor  
 Construction Manager  
 Design Professional  
 Consultant \_\_\_\_\_  
 Other \_\_\_\_\_



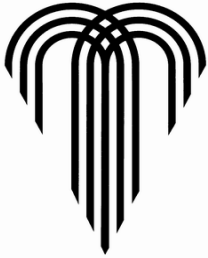

# CHANGE ORDER

**Project Number** \_\_\_\_\_

**Project Title** \_\_\_\_\_

Change Order No: \_\_\_\_\_ Date of Issuance: \_\_\_\_\_

Ordinance No: \_\_\_\_\_ Ordinance Effective Date: \_\_\_\_\_

Contract Notice To Proceed Date: \_\_\_\_\_

To CONTRACTOR:

The Contract is changed as follows: \_\_\_\_\_

\_\_\_\_\_  
\_\_\_\_\_

This Change Order constitutes compensation in full on behalf of the Contractor and its subcontractors and suppliers for all costs, including impact costs and extended general conditions, and markups directly and indirectly attributable to the Work changes ordered herein, for all delays related thereto and for performance of the changes within the time stated. Contractor hereby releases all claims for delay, interruption, extended general conditions, impact and cumulative impact claims for this Work.

[Note: Identify the specific attachments; example: "Attachment A, Additional Scope of Services." Delete all notes before printing final]

See Attached Document(s).

[Note: If the CO does not change the Contract Price, use "Director" instead of "Director of Finance"]

**Not valid until signed by the Director of Finance.**

The original Contract Price was \_\_\_\_\_ \$0.00

Net change by previously authorized Change Orders \_\_\_\_\_ \$0.00

The Contract Price prior to this Change Order was \_\_\_\_\_ \$0.00

The Contract Price will be ( increased by) ( decreased by) ( unchanged) \_\_\_\_\_ \$0.00

The new Contract Price including this Change Order will be \_\_\_\_\_ \$0.00

[Note: If revised, establish and enter new dates. If unchanged, enter current contract dates.

If you are only changing the Final Completion date, add the following reference:

"The Contract Time for Final Completion will be . . ."]

The Contract Time will be ( increased by) ( decreased by) ( unchanged) \_\_\_\_\_ ( ) calendar days

The date of Substantial Completion as of the date of this Change Order therefore is \_\_\_\_\_ Enter Date

The date of Final Completion as of the date of this Change Order therefore is \_\_\_\_\_ Enter Date

Project No. & Title  
 Change Order No.

[Note: Include any required additional signatures.]

<b>DESIGN PROFESSIONAL:</b>	By:	Date:
	Title:	
<b>CONTRACTOR:</b>	By:	Date:
	Title:	
<b>CITY:</b>	By:	Date:
	Title:	

Approved as to form: \_\_\_\_\_  
 Assistant City Attorney

[Note: If this CO does not change the Contract Price, delete the cert. of funds by Finance Director but send signed copy to Finance.]

I certify there is a balance otherwise unencumbered to the credit of the appropriation to which the above amount is chargeable, and a cash balance otherwise unencumbered in the treasury to the credit of the fund from which payment is to be made, each sufficient to meet the above obligation.

By: \_\_\_\_\_  
 Director of Finance Date

- Distribution:
- CITY
  - CONTRACTOR
  - DESIGN PROFESSIONAL

**REMINDER:** CONTRACTOR is responsible for considering the effect this Change Order may have on its ability to meet or exceed the D/M/WBE participation amounts in its Contractor Utilization Plan (CUP) as amended by any previously approved Request for Modification/Substitution. If CONTRACTOR will not be able to achieve the approved participation amounts in performing the work included within this Change Order, or if CONTRACTOR needs to retain the services of additional D/M/WBEs not previously listed in its CUP, CONTRACTOR is advised to submit a Request for Modification/Substitution.



# WORK CHANGE DIRECTIVE

Project Number \_\_\_\_\_

Project Title \_\_\_\_\_

No.: \_\_\_\_\_ Date of Issuance: \_\_\_\_\_

TO: (CONTRACTOR)

You are directed to proceed promptly with the following work:

Description:

Purpose of Work Change Directive:

Attachments: *(List documents supporting change)*

If the above work results on a change in the Contract Price or Contract Times, any request for a Change Order based thereon will involve one or more of the following methods of determining the effect of the change(s).

Method of determining change in  
Contract Price:

Method of determining change in  
Contract Times:

- Unit Prices
- Lump Sum
- As Stipulated in General Conditions
- Other \_\_\_\_\_

- CONTRACTOR's Records
- DESIGN PROFESSIONAL's Records
- City's Records
- Other \_\_\_\_\_

Estimated increase (decrease) in Contract Price:  
\$ \_\_\_\_\_

Estimated increase (decrease) in Contract Times:  
Substantial Completion: \_\_\_\_\_ days;

If the change involves an increase, the estimated Amount is not to be exceeded without further authorization.

Final Completion: \_\_\_\_\_ days.  
If the change involves an increase, the estimated times are not to be exceeded without further authorization.

Recommended:

Recommended:

Recommended:

DESIGN PROFESSIONAL

Construction Manager

City

By (Authorized Signature)

By (Authorized Signature)

By (Authorized Signature)

Distribution:

- City
- Contractor
- Construction Manager

- Design Professional
- Consultant
- Other

# WORK CHANGE DIRECTIVE (“WCD”) INSTRUCTIONS

---

**[Note: Do not attach these instructions to the WCD Form]**

## **A. GENERAL INFORMATION**

This document was developed for use in situations involving changes in the Work which, if not processed expeditiously, might delay the Project. These changes are often initiated in the field and may affect the Contract Price or the Contract Times. This is not a Change Order, but only a directive to proceed with Work that may be included in a subsequent Change Order. If the WCD may result in an increase in the Contract Price, a contract impact cost analysis must be performed prior to issuing the WCD. Availability of funds and authorization to expend funds must be part of the analysis.

For supplemental instructions and minor changes not involving a possible change in the Contract Price or the Contract Times a Supplemental Design Instruction may be used.

## **B. COMPLETING THE WORK CHANGE DIRECTIVE FORM**

Based on conversations between Design Professional, City’s Representative and CONTRACTOR, Design Professional must complete the following:

**DESCRIPTION:** shall include a summary of the Work included in the WCD. Additional information may be attached to the WCD to further define the scope.

**PURPOSE OF WORK CHANGE DIRECTIVE:** will identify clearly if the Work included in the WCD is an addition, deletion, revision, or some combination.

**ATTACHMENTS:** shall identify all attachments included in and made a part of the WCD. Be certain that attachments are clearly labeled.

**METHOD OF DETERMINING CHANGE, IF ANY, IN CONTRACT PRICE:** Mark the method to be used in determining the final cost of Work involved and the estimated net effect on the Contract Price. If the change involves an increase in the Contract Price and the estimated amount is approached before the additional or changed Work is completed, another WCD must be issued to change the estimated price. Do not leave blank spaces or write “To be determined” (or “TBD”). An estimated dollar figure must be assigned to the Work. If the WCD is not likely to change the Contract Price, the space for estimated increase (decrease) should be marked “No Change in Price”.

**METHOD OF DETERMINING CHANGE, IF ANY, IN CONTRACT TIMES:** Mark the method to be used in determining the change in Contract Times and the estimated increase or decrease in Contract Times. If the change involves an increase in the Contract Times and the estimated times are approached before the additional or changed Work is completed, another WCD must be issued to change the times or CONTRACTOR may stop the changed Work when the estimated times are reached. Do not leave blank spaces or write “To be determined” (or “TBD”). If the WCD is not likely to change the Contract Times, the space for estimated increase (decrease) should be marked “No Change in Times”.

Once Design Professional has completed and signed the form, all copies should be sent to CITY for authorization because Design Professional does not have authority to authorize changes in Price or Times. Once authorized by CITY, a copy must be sent by Design Professional to CONTRACTOR. Price and Times may only be changed by Change Order signed by CITY, Design Professional, and CONTRACTOR. If the value of the work included in the WCD exceeds the contingency or budget available for the contract, staff must obtain written approval from the Director or his or her designee before the WCD is issued. A Director or his or her designee may not approve a WCD that will exceed City Council authorization. If the work included in the WCD is needed as a result of an emergency, staff may proceed with the issuance of the WCD without

prior written approval even if the value of the work added is expected to exceed the contract contingency balance.

Once the Work covered by this directive is completed or final cost and times are determined. CONTRACTOR must submit proper documentation for inclusion in a Change Order.

**IF THIS IS A DIRECTIVE TO PROCEED WITH A CHANGE THAT MAY AFFECT THE CONTRACT PRICE OR THE CONTRACT TIMES A CHANGE ORDER, IF ANY, MUST BE PROCESSED PROMPTLY.**

**SECTION 01000**  
**PROJECT REQUIREMENTS**

**1. DESCRIPTION OF WORK:**

A. General

1. The Contractor will provide a minimum of three full-time crews for the duration of the contract to supplement KC Water repair efforts on water mains breaks, valves, hydrants, service lines and other water distribution water system assets. When requested by KC Water, Contractor shall provide an extra crew, with a total of four crews simultaneously when needed due to workload. The makeup of the crew(s) shall be tailored as needed to complete the assigned WO.
2. The Contractor will be expected to complete work orders each week as new work orders are assigned to the Contractor. The work will include frequent emergency repairs that require night and weekend on-call emergency work that require a two-hour response time.
2. KC Water will provide job assignments in the form of a Hansen Work Order (WO). Contractor will have online access to view and update work orders in real time.
3. Contractor shall complete work orders within the time frames stated in section 00800 – Supplementary General Conditions.

B. Work Order Process

1. Work order assignments will be conveyed via email and will also be accessible via the Contractor online access application. The WO details will include the WO number, location (generally a street address), asset size and type, and description of the problem with priority code.
2. The Contractor will obtain the Excavation and Pavement Degradation permits and utilize unit item No. 20. Other specialized or unique services, labor, equipment to be reimbursed. Unless otherwise directed by KC Water, the Contractor will be responsible for restoring repair sites with the exception of asphalt which will be restored by KC Water.
3. Contractor's personnel shall locate and operate valves required for valve repairs or replacements in accordance with WSD procedures, including but not limited to, scheduling of test shuts and main shuts with the WSD and providing proper notification to customers impacted by the shuts when a KC Water Inspector is not available to perform these valve shut tasks.
4. Contractor shall schedule shuts and repairs in coordination with a KC Water repair inspector and in a way to minimize water disruptions to KC Water customers.



5. The Contractor shall make the repairs in accordance with City and KC Water standards and at the direction of KC Water personnel. Contractor shall comply with KC Water standard operating procedures for preventing contamination of water mains, disinfection, flushing, de-chlorination, and putting mains back into service.
6. The Contractor shall backfill the excavation as required by KC Water specifications and in accordance with the current Kansas City SR-1 specification for street patches. Contractor shall pour the concrete trench cap to surface level when working in asphalted areas. Concrete surface shall be smooth and level with the surrounding pavement with a medium broom finish. Contractor shall cause a restoration work order to be linked to the repair work order in CITY's Hansen work order system at the time when the repair work order is closed.
7. Once the repair has been completed as the water is restored, Contractor shall provide the following information to KC Water dispatch and also send via Email to the KC Water Repair distribution list within 12 hours of completing each WO:
  - Hansen Number:
  - Address
  - Summary of Work Performed:
  - Type of Break and Type of Pipe
  - Crew size
  - Date & time on Site
  - Date & time off Site
  - Restoration needed
  - Street Plate information where applicable
  - Job Site Forman Name:
  - Dispatcher Name and Time Called:
  - Valve Shut #:
8. Site Photos
  - a. Take pre, during, and post-construction photos of each work site and upload these photos using the online contractor application to the WO associated with the work site within 24 hours of the work order completion time.
  - b. Each photo shall be identified with the work order number or address of the work, either in the photo file name or visible within the photo itself.
  - c. Each photo will include a visible time/date stamp and shall be a minimum 3 megapixel resolution.
  - d. Post-construction photos shall clearly show the area that was repaired after all work, including site cleanup, is complete.

- e. If unexpected special conditions were encountered at a site before the restoration work was completed, CONTRACTOR shall send CITY additional photo(s) showing those special conditions.
9. Contractor shall use the online contractor application to enter the total work order cost and upload jobsite photos. Where restoration is required, CONTRACTOR shall cause a restoration work order to be linked to the repair work order in CITY's Hansen work order system at the time when the repair work order is closed.

### C. Additional Contractor Responsibilities

In addition to the previously listed requirements, the Contractor shall:

1. Identify and provide email addresses and mobile phone numbers for the Contractor's project manager, superintendent, and crew chief(s). All of these people will have mobile devices capable of accessing online maps, uploading photos, and sending and receiving emails.
2. Contact Missouri 811 for locates
3. Obtain permits not obtained by KC Water
4. Coordinate, as appropriate, with the KC Water repair inspector, Meter Field Services Division, Pipeline Division, KC Water Engineering, Water Dispatch, and other appropriate parties regarding details and schedule of the repair.
5. Provide traffic control and other safety devices not already provided by KC water.
6. Perform test shuts. Valves larger than 12" shall be operated by a KC Water repair inspector.
7. Notify KC Water Dispatch when starting or completing a work order or valve shut.
8. Execute a release for receipt of licensed GIS data for water distribution mapping; maintaining confidentiality of the data in accordance with City requirements, and permanently removing the licensed materials from any media used by Contractor on closeout of the project.
9. Protect from damage any other utilities, services, lines, pipes, and other surface or subsurface features that are near the repair site. If such items are damaged by the Contractor, the Contractor shall be responsible for having such items repaired or replaced.
10. Minimize the damage to the street, curb, driveways, sidewalks, grassed areas, and surfaces during his repairs so as to minimize restoration costs.
11. Other Contractor responsibilities described elsewhere in the Contract documents.

**2. CONTRACT GENERAL SPECIFICATIONS:**

A. The work shall conform to these Project Specifications, contained within the Project Manual, and to the latest revision of KC Water Standards and Specifications for Water Main Extensions and Relocations and the Rules and Regulations for Water Service Lines, which are made a part hereof by reference. These Standards and Specifications in pdf format are available for viewing and printing from the City website at <http://www.kcmo.org>.

B. In cases where the WSD Standards and Specifications for Water Main Extensions and Relocations and Rules and Regulations for Water Service Lines, as referenced, conflict with these Project Specifications or the Project Drawings, the Project Specifications shall govern.

**3. MATERIALS FURNISHED BY THE OWNER:**

The Owner will furnish the Contractor and without charge to the Contractor, the materials listed below. If the Owners stores are out-of-stock of materials requested by the Contractor, those materials shall be obtained by the Contractor. Reimbursement for these materials shall be made in accordance with Article 11 of the General Conditions of this document. All other materials required to complete the work in accordance with the Contract Documents shall be furnished and installed by and at the expense of the Contractor.

<u>Item</u>	<u>Quantity</u>
Ductile Iron Pipe and fittings	as needed
KCMO spec fire hydrant	as needed
Valves	as needed
Valve bases, covers, boxes, risers, op nuts	as needed
Miscellaneous pipe & fittings	as needed

All material furnished by the Owner which is damaged, lost or stolen after its acceptance by the Contractor shall be replaced at the expense of the Contractor.

The Contractor, or his authorized representative, shall sign a bill of receipt for all materials withdrawn from the Water Services Department Stores. The Contractor will be responsible for pickup of materials at the Water Services Department Stores and for delivery to the work site.

All materials withdrawn from the Water Services Department Stores that are not incorporated in the work shall be returned to the Water Services Department Stores. All such material not returned shall be charged to the Contractor and deduction therefore shall be made from the final payment estimate.

All salvaged hydrants, pipe and metal parts shall be returned to the Owner at Water Services Department Stores unless otherwise directed for disposal.

**4. RESTORATION COMPLAINTS:**

CONTRACTOR shall be responsible for addressing and resolving any customer complaints regarding the quality of CONTRACTOR'S restoration in a timely manner. If CITY has to correct CONTRACTOR'S restoration work due to quality or timeliness concerns, CITY will withhold the cost of the corrected restoration work from CONTRACTOR'S payment.

**5. BACKFILL** All backfill shall be thoroughly compacted in strict conformance with KC Water Standards and Specifications for Water Main Extensions and Relocations, and the Public Works Department Pavement Restoration Standards SR-1.

**6. FACILITIES:**

A. The Owner will furnish without charge all necessary water for filling, flushing, and testing the completed line. Use of City's water facilities shall be at the direction of the Water Services Department so that water service to customers served by the facilities is not impaired. Under any conditions, water shall not be wasted. Any water furnished by the Owner must be obtained from the Owner's existing main. All material and service needed to obtain water for construction purposes shall be provided by the Contractor at his sole cost and expense.

B. All power for lighting, operation of the Contractor's plant or equipment, or for any other use which may be required for proper completion of the work to be performed shall be provided by the Contractor at his sole cost and expense.

**7. RIGHTS-OF-WAY:** The Owner will provide right-of-way necessary for construction of the water main where it is in public thoroughfares, city streets, Park Board property, county roads, state highways, or where it crosses private property. The Contractor shall confine his construction operations to the immediate vicinity of the repair location, and shall use due care in placing construction tools, equipment, excavated materials, and pipeline materials and supplies so as to cause the least possible damage to property and interference with public traffic.

Should it become necessary that the Contractor use or occupy the land outside the Owner's right-of-way, the Contractor shall obtain written consent from or execute a written agreement with the owner and tenant of such permitting such operation. The Contractor shall neither enter for pipe delivery nor occupy for any other purpose with men, tools, equipment, construction materials, or excavated materials any private property outside the right-of-way boundaries without such written permission from the owner and tenant of the entered or occupied property. Each owner and tenant of land or other property so occupied shall be notified by the Contractor not less than five (5) days prior to such occupation.

**8. POSITION, LINE OR GRADE:**

The Contractor shall furnish all labor and materials necessary in laying out the work. The Contractor shall be responsible for setting any offset stakes he may require or required by the Engineer. Contractor to locate right-of-ways as required to lay out work.

**9. DISINFECTION:**

Water mains should be kept under slight pressure until the repair area has been excavated and disinfected to prevent backflow of contaminants. All disinfection work shall be in strict conformance with KC Water Standards and Specifications for Water Main Extensions and Relocations.

**10. SETTING FIRE HYDRANTS:** Hydrants shall be installed per Section 02645 – Hydrants and Flushing Assemblies.

**11. SANITARY PROVISIONS:** The Contractor shall provide sanitary conveniences for use of all persons employed on the work. All sanitary conveniences shall conform to the regulations of the Health Department of the City, County, and State. At the completion of the work, all signs and traces of such sanitary provisions shall be removed.

**12. CLEAN-UP:**

All excavated material in excess of that necessary to fill the trench shall be removed and disposed of by the Contractor.

Surplus pipeline materials, tools, and temporary structures shall be removed by the Contractor; all rubbish shall be hauled away by the Contractor and the construction site shall be left clean. Sidewalks, driveways and streets shall be swept clean of dirt, gravel or other debris.

**13. EROSION AND SEDIMENT CONTROL:** All work shall conform to the latest revision of the Kansas City, Missouri Erosion and Sediment Control Specifications which is made a part hereof by reference.

**14. GUIDELINES FOR OPEN EXCAVATIONS:** Required excavations shall be restored to the level of the adjacent surfaces as soon as practicable. Unsupervised open excavations on public properties are not allowed. Every person who for any purpose makes or causes to be made any excavation in, upon, under, through or adjoining any street, sidewalk, alley, park, boulevard, parkway or any other public properties, and shall leave any part or portion thereof open shall provide effective protection to the public.

All excavations in roadways shall be protected and secured in compliance with existing federal, state and local codes and standards, including, but not limited to the most current editions of the Manual of Uniform Traffic Control Devices.

All excavations not within roadways shall be protected and secured. A protective cover over an excavation shall be installed so that it can sustain the weight of any persons and/or objects placed upon it. The cover shall be fixed to the ground so it cannot be moved. Protective covers shall have no opening(s) or protuberance(s) of sufficient size to cause a fall and/or injury. Advance warning devices shall be installed as necessary.

Any excavation that is not covered, shall be fenced in such a way that it surrounds the entire

area under excavation so as to prevent entry by any persons. The fencing shall be a minimum of 42" in height. The fence shall be constructed in such a manner that it is adequately secured and will remain upright at all times under normal site conditions.

All protective coverings and/or fences on excavations shall be inspected at least daily by Contractor to assure integrity. Protective coverings and/or fences in heavily trafficked areas shall be inspected more often as necessary.

**END OF SECTION 01000**

## **SECTION 01270**

### **MEASUREMENT AND PAYMENT**

#### **PART 1 – GENERAL**

##### **1.1 GENERAL**

- A. Payment for Work performed by the Contractor under these Contract Documents will be made in accordance with the General Conditions at the approved Contract Unit Price unless otherwise stated in the Contract Documents. Such payment shall compensate the Contractor for all labor, including wages, fringe benefits, employee taxes, employee liability and worker compensation insurance, vehicles, equipment, tools, overhead and profit, bonding, insurance, risk and ancillary items and tasks necessary to complete the work orders.
- B. Work required to complete assigned work orders, but which has no corresponding unit or lump sum price, shall be a subsidiary item unless otherwise specifically stated in the Contract Documents. Contractor's cost to complete subsidiary items shall be included in the Unit Prices in the Bid Form.
- C. Along with each Application for Payment, Contractor shall include documentation of the quantities included in the pay application. As part of this documentation, Contractor shall complete a Daily Crew Record for each crew for each assigned work order including Hansen Work Order No., work description, labor, hours, materials, specialized or unique labor, equipment or services used in the repair and other information as directed by KC Water. This written documentation must be provided with each Application for Payment to verify the quantities and all costs incurred.
- D. All charges for crew hours must be fully documented in the hourly wages to workers that are reported in Contractor's Daily Labor Force Reports. Costs for management, supervision, superintendence, and administration shall be included in Item 16 – Monthly Project Superintendence.

#### **PART 2 – DESCRIPTION OF UNIT PRICES**

##### **ITEMS 1 – 3: TWO-PERSON CREW FOR RELATED WORK W/O EXCAVATION**

These unit prices include mobilization/demobilization, labor, vehicles, equipment and tools necessary to complete the assigned work orders. Overtime crew rates will only be applied when all members of the crew are entitled to receive regular or double overtime pay due to hours worked on this contract.

Examples of field work without excavation include minor repairs which do not require excavation such as: replacing cover and lid, pouring concrete collar, replacing operating nuts, locating, and uncovering valves, and performing test shuts. This line item is not to supplement the excavation repair crews. If an excavation repair crew size larger than

three-person is needed then the unit price for three-person for repair/ replacements will be utilized to include all extra needs.

#### ITEMS 4 – 9: TWO OR THREE-PERSON CREW FOR REPAIR/REPLACEMENTS

These unit prices include mobilization/demobilization, utility locates, labor, vehicles and all equipment and tools necessary to complete the assigned work orders including but not limited to equipment, vehicles, equipment, pavement and pipe saws, hydraulic hammer, loaders, pumps, generators, air compressors and hammers, and small tools. Cost of pickup of materials from the Owner's stores and transport to the site shall be included in this unit price. This unit price for three-person crew for repair/replacements should include extra expected ancillary staffing needs, such as to pick up parts, etc. Overtime crew rates will be applied only when all members of the crew are entitled to receive regular or double overtime pay due to hours worked on this contract.

#### ITEM 10: GRANULAR EMBEDMENT:

The quantity of granular embedment needed for proper pipe bedding to complete each Work Order shall be identified per ton used. The cost of labor and equipment for placing and compacting the material as pipe embedment at the work site shall be paid using the appropriate unit price for the crew and equipment.

#### ITEMS 11-12: HAULING AND DISPOSAL:

Contractor shall be responsible for the removal of all waste materials generated during the completion of the Work Order. Job excavated materials not suitable for use as backfill or surplus job excavated soils, pavement materials removed for the repair or replacement, debris, abandoned pipe and valve materials not directed by Owner for salvage, etc. shall be removed from the jobsite and properly disposed of. Payment will be made on the basis of truck loads from the site and the unit price shall include all equipment, labor, and disposal fees and any other costs to remove the material from the site and proper disposal.

#### ITEM 13: CONCRETE:

The quantity of concrete necessary to complete assigned Work Orders in accordance with all aspects of Contract specifications for flatwork, base concrete and the construction of thrust blocks behind fittings or saddle blocks shall be paid per cubic yard used. Payment for concrete shall be made at the approved contract unit price for concrete per cubic yard delivered and placed. This cost includes delivery, formwork where needed, reinforcing, and all other incidentals. The cost of labor and equipment for placing the concrete at the work site shall be paid using the appropriate unit price for the crew and equipment.

#### ITEM 14: DIGGABLE FLOWABLE FILL (CONTROLLABLE LOW STRENGTH MATERIAL, CLSM):

The quantity of diggable flowable fill necessary to complete assigned Work Orders in accordance with all aspects of Contract specifications shall be identified per cubic yard



used. Payment for diggable flowable fill shall be made at the approved contract unit price for fill per cubic yard delivered and placed. The cost of labor and equipment for placing the material at the work site shall be included in this line item. Diggable flowable fill (aka CLSM) shall correspond to the requirements of Section 02250 – Trenching, Pipe Embedment and Backfill.

**ITEM 15: TWO-PERSON CREW WITH HYDRO EXCAVATOR FOR REPAIRS:**

This unit price include mobilization/demobilization, labor, vehicles and all equipment and tools necessary to provide and operate a hydro excavator for related repairs, including removal of debris from valve boxes or stand pipes.

**ITEM 16: MONTHLY PROJECT SUPERINTENDENCE:**

Payment for monthly project superintendence will be a lump sum monthly charge to account for overall project field superintendence, supervision, coordination, meetings, billing, compliance, management, support, overhead, technology administrative work not included in other unit price items.

**ITEM 17: SPECIALIZED TRAFFIC CONTROL:**

Payment for specialized traffic control for an assigned Work Order will be made in accordance with Article 11 of the General Conditions of the Contract, including preparation of the traffic control plan, permit fees, and the provision and maintenance of appropriate traffic control devices for the work. Minor traffic control such as placement of traffic cones or barricades at or around the work site or equipment shall be considered subsidiary to the other unit prices and not billed separately.

**ITEM 18: STREET PLATES:**

A portion of street plates will be provided, delivered, and picked up by KC Water. In cases where Contractor provides his own street plates, payment for the provision of street plate(s) over a pavement cut for an assigned Work Order will be made per plate per day needed. This price includes the permit fee, rental fee if any, delivery, pickup, and embedment where required.

**ITEM 19: MATERIALS NOT AVAILABLE FROM OWNER'S STORES:**

If materials (pipe, fittings, valves, and appurtenances listed in Section 01000 as to be furnished by Owner required for an assigned work order are not available through the Owner's Stores, upon approval by KC Water those materials shall be obtained by the Contractor and delivered to the work site. Reimbursement for these materials shall be made in accordance with Article 11 of the General Conditions of the Contract.

**ITEM 20: OTHER SPECIALIZED SERVICES:**

Payment for other specialized and unique services required for assigned work orders and pre-approved, in writing, by KC Water will be made in accordance with Article 11 of the General Conditions of the Contract.

ITEM 21: WEEKDAY CREW ON-CALL PER CREW:

Payment for weekday emergency on-call will be for each 24 hour period each standby crew(s) is on-call during a weekday Monday 7am through Friday 7am. One to four crews may be needed due to workload. KC Water will notify the Contractor of on-call requirements at least 24 hours in advance.

ITEM 22: WEEKEND/HOLIDAY ON-CALL PER CREW:

Payment for weekend/ holiday emergency on-call will be for each 24 hour period each standby crew(s) is on-call during weekends Friday 7am through Monday 7am or Federal holiday. One to four crews may be needed due to workload. KC Water will notify the Contractor of on-call requirements at least 24 hours in advance.

END OF SECTION



# APPLICATION FOR PAYMENT

**Project Number** 80002486/9829

**Project Title** Emergency Water Distribution System Repairs

Final Payment<sup>5</sup>

CONTRACTOR \_\_\_\_\_

Address \_\_\_\_\_

Application Number<sup>2</sup>: \_\_\_\_\_  
 Date: \_\_\_\_\_  
 Ordinance/Resolution Number: \_\_\_\_\_  
 Effective: \_\_\_\_\_  
 PO Number: \_\_\_\_\_  
 Vendor Number: \_\_\_\_\_

Application for Work Accomplished from \_\_\_\_\_ to \_\_\_\_\_

Original Contract Price	[1]		\$	-
Net by Change Orders through		[2]	\$	-
Current Contract Price (1+2)		[3]	\$	-
Completed Work	[4]	\$	-	
Disputed Amounts <sup>3</sup>	[-]	[4a]	\$	-
Stored Material <sup>4</sup>	[5]	\$	-	
Disputed Amounts <sup>3</sup>	[-]	[5a]	\$	-
Total Completed and Stored to Date (4+5)		[6]	\$	-
Previous Payments	[7]	\$	-	
Previous Retainage	[8]	\$	-	
Total Previous Applications (7+8)		[9]	\$	-
Amount This Application (6-9)		[10]	\$	-
Less Retainage This Application (5%)		[-]	[11]	\$ -
Release of Retainage		[12]	\$	-
Total Due This Application (10-11+12)		[13]	\$	-
Liquidated Damages				
Completion of Work	[14]	\$	-	[-] \$ -
Prevailing Wage <sup>7</sup>	[15]	\$	-	[-] \$ -
MBE/WBE Program <sup>7</sup>	[16]	\$	-	[-] \$ -
Workforce Program <sup>7</sup>	[17]	\$	-	[-] \$ -
<b>Total Amount Due Contractor (13 - 14 through 17)</b>		[18]	\$	-

Accompanying Documentation: <sup>1, 2, 3, 4, 5, & 6</sup> and any other information as necessary.

NOTE: Initial all figures on this Application and on the Schedule of Values that are changed to correct errors or conform to the amount recommended. Attach explanation of changes that have been made.

**CONTRACTOR's Certification:**

The undersigned CONTRACTOR certifies that (a) all previous progress payments received from OWNER on account of Work done under this Contract have been applied on account to discharge CONTRACTOR's legitimate obligations incurred in connection with Work covered by all prior Applications for Payment; (b) at time of payment, title of all Work, materials and equipment incorporated into said Work or otherwise listed in or covered by this Application for Payment will pass to OWNER free and clear of all Liens, security interests and encumbrances (except such as are covered by a Bond acceptable to OWNER indemnifying OWNER against any such Lien, security interest or encumbrance); and (c) all Work covered by this Application for Payment is in accordance with the Contract Documents and not defective; and (d) all manufactured goods or commodities used or supplied for this Project are in compliance with Kansas City's Buy America ordinance.

By \_\_\_\_\_  
 Contractor Authorized Representative (Print) Signature

Date \_\_\_\_\_

State of \_\_\_\_\_ )  
 County of \_\_\_\_\_ )SS

Subscribed and Sworn to before me this \_\_\_\_\_ day of \_\_\_\_\_.

My commission expires:

Notary Public: \_\_\_\_\_

DESIGN PROFESSIONAL's Recommendation of Payment:

In accordance with the Contract Documents, based on on-Site observations and the data comprising this application, the DESIGN PROFESSIONAL recommends to the OWNER that to the best of the DESIGN PROFESSIONAL's knowledge, information and belief the Work has progressed as indicated, the quality of the Work is in accordance with the Contract Documents, and the CONTRACTOR is entitled to payment of the Amount above listed in this application.

\_\_\_\_\_  
Name of firm (Print)                      DESIGN PROFESSIONAL (Print)                      (Signature)

Date: \_\_\_\_\_

Construction/Program Manager's Recommendation of Payment: (if applicable)

In accordance with the Contract Documents, based on on-Site observations and the data comprising this application, the Construction/Program Manager recommends to the OWNER that to the best of the Construction/Program Manager's knowledge, information and belief the Work has progressed as indicated, the quality of the Work is in accordance with the Contract Documents, and the CONTRACTOR is entitled to payment of the Amount above listed in this application.

\_\_\_\_\_  
Construction/Program Manager firm (Print)                      Authorized Representative (Print)                      (Signature)

Date: \_\_\_\_\_

City's Representative's Agreement with Recommendation of Payment

\_\_\_\_\_  
City's Representative(print)                      (Signature)                      (Date)

City's Approval

The amount previously recommended is approved for payment.

\_\_\_\_\_  
Director or Designee (Print)                      (Signature)                      (Date)

<sup>1</sup>See General Conditions Article 14.02 A and B

<sup>2</sup>Proof of tax compliance if 1st payment and if Contract amount exceeds \$150,000.00

<sup>3</sup>Schedule of Values--Denote any amounts currently disputed in this application. Attach additional dispute documentation if required.

<sup>4</sup>If requesting payment for stored materials, see General Conditions Article 14.02 A.1

<sup>5</sup>If final payment, current proof of tax compliance if Contract is longer than 1 year and amount exceeds \$150,000.00.

<sup>6</sup> Per General Conditions Sec. 14.02 attach a copy of the most recent 00485.01 M/WBE Monthly Utilization Report, 00485.02 Project Workforce Monthly Report and 00485.03 Company-Wide Workforce Monthly Report CONTRACTOR has submitted to the City's Human Relations Department

<sup>7</sup>Applicable only if final payment

**REMINDER:** CONTRACTOR is responsible for meeting or exceeding the the D/M/WBE participation amounts in its Contractor Utilization Plan (CUP) as amended by any previously approved Request for Modification/Substitution. Any Change Orders or amendments modifying the amount CONTRACTOR is to be compensated will have correspondingly impacted the amount of compensation due D/M/WBEs for purposes of meeting or exceeding the Bidder/Proposer participation. CONTRACTOR is again reminded to consider the effect of any Change Order or amendment, and to submit a Request for Modification/Substitution if appropriate.

Distribution:      Owner                      Project Manager  
                         Contractor                      Design Professional  
                         Construction Manager                      \_\_\_\_\_





## SUBCONTRACTORS AND MAJOR MATERIAL SUPPLIERS LIST

Project Number \_\_\_\_\_ Project Title \_\_\_\_\_

From Contractor \_\_\_\_\_ To \_\_\_\_\_ Date \_\_\_\_\_

Spec. No.	Section Title	4	Firm, Address (Check box if Supplier)	Phone, FAX and e-mail	Contact

Attachments:

Signed by: \_\_\_\_\_ Date \_\_\_\_\_

Distribution:  Owner  Contractor  Construction Manager  Design Professional  Consultant  Other

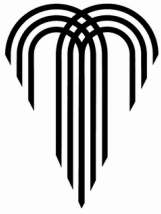

# DAILY LABOR FORCE REPORT

Project Number \_\_\_\_\_ Day \_\_\_\_\_ Date \_\_\_\_\_

Project Title \_\_\_\_\_

Contractor \_\_\_\_\_

Subcontractor \_\_\_\_\_

Weather: (Indicate if weather prevented work and why) \_\_\_\_\_

Shift: (circle) 5-8 hr Days 4-10 hr Days Other \_\_\_\_\_

\* This report *MUST* be completed and turned in for EACH DAY until FINAL COMPLETION.

Worker's Full Legal Name	Occupational Title or Classification Group & Skill	Hours Worked & Time (i.e. 10AM – 4PM)	Race & Gender

I CERTIFY THAT ALL OF THE INFORMATION PROVIDED ABOVE IS TRUE AND COMPLETE.

Contractor/Subcontractor Representative:

Complete Name: (print) \_\_\_\_\_ Title: (print) \_\_\_\_\_

Signature: \_\_\_\_\_

Page \_\_\_\_ of \_\_\_\_

Distribution:  City Department  Contractor  Subcontractor  Other



# CERTIFICATE OF SUBSTANTIAL COMPLETION

Project Number \_\_\_\_\_

Project Title \_\_\_\_\_

CONTRACT FOR: \_\_\_\_\_

CONTRACTOR: \_\_\_\_\_

DATE OF ISSUANCE: \_\_\_\_\_

**PROJECT OR DESIGNATED PORTION SHALL INCLUDE:**

The Work performed under this Contract has been reviewed and found, to the Design Professional's and/or Construction Manager's best knowledge, information and belief, to be substantially complete. Substantial Completion is the state in the progress of the Work when the Work or designated portion thereof is sufficiently complete in accordance with the Contract Documents so the Owner can occupy or utilize the Work for its intended use. The date of Substantial Completion of Project or portion thereof designated above is hereby established as \_\_\_\_\_ which is also the date of commencement of applicable warranties required by the Contract Documents, except as stated below:

A list of items to be completed or corrected is attached hereto. The failure to include any items on such list does not alter the responsibility of the Contractor to complete all Work in accordance with the Contract Documents.

\_\_\_\_\_  
CONSTRUCTION MANAGER BY \_\_\_\_\_ DATE \_\_\_\_\_

\_\_\_\_\_  
DESIGN PROFESSIONAL BY \_\_\_\_\_ DATE \_\_\_\_\_

The Contractor will complete or correct the Work on the list of items attached hereto within \_\_\_\_\_ days from the above date of Substantial Completion.

\_\_\_\_\_  
CONSTRUCTION MANAGER BY \_\_\_\_\_ DATE \_\_\_\_\_

\_\_\_\_\_  
DESIGN PROFESSIONAL BY \_\_\_\_\_ DATE \_\_\_\_\_

The Owner accepts the Work or designated portion thereof as substantially complete and will assume full possession thereof at \_\_\_\_\_ (time) on \_\_\_\_\_ (date).

\_\_\_\_\_  
OWNER'S REPRESENTATIVE BY \_\_\_\_\_ DATE \_\_\_\_\_

- Distribution:
- Owner
  - Contractor
  - Construction Manager
  - Design Professional
  - Consultant \_\_\_\_\_
  - Other \_\_\_\_\_





# PUNCH LIST

Project Number \_\_\_\_\_

Project Title \_\_\_\_\_

CONTRACTOR \_\_\_\_\_

From \_\_\_\_\_ Site Visit Date \_\_\_\_\_

The following items require the attention of the CONTRACTOR for completion or correction. This list may not be all-inclusive, and the failure to include any items on this list does not alter the responsibility of the CONTRACTOR to complete all Work in accordance with the Contract Documents.

Item No.	Location (Area)	Description	Correction/ Completion Date	Verification Check
----------	-----------------	-------------	-----------------------------	--------------------

Attachments

Signed by: \_\_\_\_\_ Date: \_\_\_\_\_

DESIGN PROFESSIONAL (Firm/In House)

- Distribution:
- OWNER
  - CONTRACTOR
  - DESIGN PROFESSIONAL
  - Consultant \_\_\_\_\_
  - Other \_\_\_\_\_



## CONTRACTOR AFFIDAVIT FOR FINAL PAYMENT

Project Number \_\_\_\_\_

Project Title \_\_\_\_\_

STATE OF \_\_\_\_\_ )  
 )SS  
COUNTY OF \_\_\_\_\_ )

The Undersigned, \_\_\_\_\_ of lawful  
(Name)

age, being first duly sworn, states under oath as follows:

1. I am the \_\_\_\_\_ of \_\_\_\_\_ who is the general  
(Title) (CONTRACTOR)  
CONTRACTOR for the CITY on Project No. \_\_\_\_\_ and Project Title \_\_\_\_\_.

2. All payrolls, material bills, use of equipment and other indebtedness connected with the Work for this Project have been paid and all Claims of whatever nature have been satisfied, as required by the Contract.

3 (✓) \_\_\_ Prevailing wage does not apply; or

(✓) \_\_\_ All provisions and requirements set forth in Chapter 290, Section 290.210 through and including 290.340, Missouri Revised Statutes, pertaining to the payment of wages to workmen employed on public works projects have been fully satisfied and there has been no exception to the full and complete compliance with these provisions and requirements and the Annual Wage Order contained in the Contract in carrying out the Contract and Work. CONTRACTOR has fully complied with the requirements of the prevailing wage law as required in the Contract and has attached affidavits from all Subcontractors on this Project, regardless of tier, affirming compliance with the prevailing wage law as stipulated in the Contract.

4. I hereby certify that (a) at project completion and pursuant to contractor's final request for payment, contractor achieved (\_\_\_\_%) Minority Business Enterprise (MBE) participation and (\_\_\_\_%) Women Business Enterprise (WBE) participation on this contract, and (b) listed herein are the names of all certified M/WBE subcontractors, regardless of tier, with whom I, or my subcontractors contracted.

1. Name of MBE/WBE Firm \_\_\_\_\_  
Address \_\_\_\_\_  
\_\_\_\_\_  
Telephone Number (\_\_\_\_\_) \_\_\_\_\_  
IRS Number \_\_\_\_\_  
Area/Scope\*of Work \_\_\_\_\_  
Subcontract Final Amount \_\_\_\_\_

2. Name of MBE/WBE Firm \_\_\_\_\_  
Address \_\_\_\_\_  
\_\_\_\_\_  
Telephone Number (\_\_\_\_\_) \_\_\_\_\_  
IRS Number \_\_\_\_\_  
Area/Scope\*of Work \_\_\_\_\_  
Subcontract Final Amount \_\_\_\_\_

List additional subcontractors, if any, on a similar form and attach to the bid.

Supplier\*\* Final Amount: \_\_\_\_\_

\*Reference to specification sections or bid item number.

- (✓) \_\_\_ Met or exceeded the Contract utilization goals; or
- (✓) \_\_\_ Failed to meet the Contract utilization goals (attach waiver, substitution or modification); or
- (✓) \_\_\_ No goals applied to this Project.

5. CONTRACTOR certifies that each Subcontractor has received full payment for its respective work in connection with the Contract.

6. If applicable, I hereby certify that (1) at project completion and pursuant to contractor's final request for payment, contractor achieved, company-wide, at least ten percent (10%) minority workforce participation and two percent (2%) women workforce participation and (2) a true and accurate copy of my final project workforce monthly report is attached. **NOTE: This paragraph is only applicable if you completed a construction contract that was estimated by the City, prior to solicitation, as requiring more than 800 construction labor hours and costing in excess of \$300,000.00. If applicable you MUST attach copies of your final monthly workforce reports.**

7. This affidavit is made in behalf of the CONTRACTOR for the purpose of securing from Kansas City, Missouri, the certification of completion of the Project and receiving payment therefore.

8. If the Contract amount exceeded \$150,000, CONTRACTOR has submitted proof of compliance with the City tax ordinances administered by the City's Commissioner of Revenue and has on file proof of tax compliance from all Subcontractors. If the Contract term exceeded one (1) year, CONTRACTOR has provided proof of compliance with the City tax ordinances administered by the City's Commissioner of Revenue prior to receiving final payment and has on file proof of tax compliance from all Subcontractors prior to the Subcontractor receiving final payment from CONTRACTOR.

CONTRACTOR \_\_\_\_\_

By \_\_\_\_\_  
(Authorized Signature)

Title \_\_\_\_\_

On this \_\_\_\_\_ day of \_\_\_\_\_, \_\_\_\_\_, before me appeared \_\_\_\_\_, to me personally known to be the \_\_\_\_\_ of the \_\_\_\_\_,

and who executed the foregoing instrument and acknowledged that (s)he executed the same on behalf of \_\_\_\_\_ as its free act and deed.

IN WITNESS WHEREOF, I have hereunto set my hand and affixed my official seal on the day and year first above written.

My commission expires:

\_\_\_\_\_  
Notary Public



# SUBCONTRACTOR AFFIDAVIT FOR FINAL PAYMENT

Project Number \_\_\_\_\_

Project Title \_\_\_\_\_

STATE OF MISSOURI )

) ss:

COUNTY OF \_\_\_\_\_ )

After being duly sworn the person whose name and signature appears below hereby states under penalty of perjury that:

1. I am the duly authorized officer of the business indicated below (hereinafter Subcontractor) and I make this affidavit on behalf of Subcontractor in accordance with the requirements set forth in Section 290.290, RSMo. Subcontractor has completed all of the Work required under the terms and conditions of a subcontract as follows:

Subcontract with: \_\_\_\_\_, Contractor

Work Performed: \_\_\_\_\_

Total Dollar Amount of Subcontract and all Change Orders: \$ \_\_\_\_\_

City Certified MBE WBE DBE NA  
List certifications:

2. Subcontractor fully complied with the provisions and requirements of the Missouri Prevailing Wage Law set forth in Sections 290.210, RSMo through 290.340, RSMo.

**Business Entity Type:**

- Missouri Corporation
- Foreign Corporation
- Fictitious Name Corporation
- Sole Proprietor
- Limited Liability Company
- Partnership
- Joint Venture
- Other (Specify)

**Subcontractor's Legal Name and Address**

\_\_\_\_\_  
 \_\_\_\_\_  
 Phone No. \_\_\_\_\_  
 Fax: \_\_\_\_\_  
 E:mail: \_\_\_\_\_  
 Federal ID No. \_\_\_\_\_

I hereby certify that I have the authority to execute this affidavit on behalf of Subcontractor.

By: \_\_\_\_\_  
 (Signature)  
 \_\_\_\_\_  
 (Title)

\_\_\_\_\_  
 (Print Name)  
 \_\_\_\_\_  
 (Date)

**NOTARY**

Subscribed and sworn to before me this \_\_\_\_ day of \_\_\_\_\_, 20\_\_\_\_.

My Commission Expires: \_\_\_\_\_ By \_\_\_\_\_

\_\_\_\_\_  
Print Name

\_\_\_\_\_  
Title



# DAILY FIELD OBSERVATION REPORT

Project Number \_\_\_\_\_

Project Title \_\_\_\_\_

Contractor \_\_\_\_\_

Report Number \_\_\_\_\_ Date \_\_\_\_\_ Time \_\_\_\_\_

Weather

- Clear     Snow  
 Overcast     Foggy  
 Rain     Cold

- Warm  
 Hot  
 Temperature Range \_\_\_\_\_

Site Conditions

- Clear     Dusty  
 Muddy     \_\_\_\_\_  
 Temperature Range \_\_\_\_\_

Day

- Monday     Thursday  
 Tuesday     Friday  
 Wednesday     \_\_\_\_\_

Persons Contacted:

Work Observed:

Items Discussed:

Materials Delivered:

Requested Revisions or Interpretations:

Nonconforming Work Reported This Date To Contractor:

Remarks:

Attachments

Signed by: \_\_\_\_\_

Date: \_\_\_\_\_

- Distribution:
- Owner
  - Contractor
  - Construction Manager
  - Design Professional
  - Consultant \_\_\_\_\_
  - Other \_\_\_\_\_

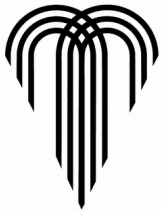

# PERIODIC FIELD OBSERVATION REPORT

Project Number \_\_\_\_\_

Project Title \_\_\_\_\_

Contractor \_\_\_\_\_

Report Number \_\_\_\_\_ Date \_\_\_\_\_ Time \_\_\_\_\_

Weather

- Clear     Snow  
 Overcast     Foggy  
 Rain     Cold

- Warm  
 Hot  
 Temperature Range \_\_\_\_\_

Site Conditions

- Clear     Dusty  
 Muddy     \_\_\_\_\_  
 Temperature Range \_\_\_\_\_

Day

- Monday     Thursday  
 Tuesday     Friday  
 Wednesday     \_\_\_\_\_

Persons Contacted:

Work Observed:

Items Discussed:

Remarks:

Attachments

Signed by: \_\_\_\_\_

Date: \_\_\_\_\_

- Distribution:  Owner  
 Contractor  
 Construction Manager  
 Design Professional  
 Consultant \_\_\_\_\_  
 Other \_\_\_\_\_



## WEEKLY REPORT OF WORKING DAYS

Project Number \_\_\_\_\_

Project Title \_\_\_\_\_

Contractor \_\_\_\_\_

Report Number \_\_\_\_\_ Week Ending: \_\_\_\_\_

DATE:	WORKING DAY	REMARKS		
TOTAL THIS WEEK	PREVIOUSLY	TOTAL TO DATE	WORKING DAYS IN CONTRACT	REMAINING OR OVERTIME

Signed by OWNER'S REPRESENTATIVE \_\_\_\_\_ Date: \_\_\_\_\_

Signed by CONTRACTOR \_\_\_\_\_ Date: \_\_\_\_\_

Distribution:    OWNER    CONTRACTOR    Construction Manager    Design Professional    Consultant    Other



# TRANSMITTAL LETTER

Project Number \_\_\_\_\_

Project Title \_\_\_\_\_

---

TO: \_\_\_\_\_ Date \_\_\_\_\_  
 \_\_\_\_\_ Re: \_\_\_\_\_  
 \_\_\_\_\_  
 \_\_\_\_\_  
 \_\_\_\_\_  
 \_\_\_\_\_

ATTN: \_\_\_\_\_

---

- We are sending you  Attached  Under separate cover via \_\_\_\_\_ the following items:
- Shop Drawings  Prints  Drawings  Samples  Specifications
- Copy of Letter  Change Order  \_\_\_\_\_

Copies	Date	No.	Description

- These are transmitted as checked below:
- For Approval  Approved as Submitted  Resubmit \_\_\_\_\_ Copies for Approval
- For Your Use  Approved as Noted  Submit \_\_\_\_\_ Copies for Distribution
- As Requested  Returned for Corrections  Return \_\_\_\_\_ Corrected Prints
- For Review and Comment  \_\_\_\_\_

Remarks: \_\_\_\_\_

\_\_\_\_\_

\_\_\_\_\_

\_\_\_\_\_

\_\_\_\_\_

\_\_\_\_\_

\_\_\_\_\_

By: \_\_\_\_\_

- Distribution:
- Owner
  - Contractor
  - Construction Manager
  - Design Professional
  - Consultant
  - Other





## SUBSTITUTION REQUEST

Project Number \_\_\_\_\_

Project Title \_\_\_\_\_

To: \_\_\_\_\_

Authorization Number: \_\_\_\_\_

Re: \_\_\_\_\_

From: \_\_\_\_\_

Date: \_\_\_\_\_

Contract For: \_\_\_\_\_

Specification Title: \_\_\_\_\_

Section: \_\_\_\_\_ Page: \_\_\_\_\_ Article/Paragraph: \_\_\_\_\_

Proposed Substitution: \_\_\_\_\_

Manufacturer: \_\_\_\_\_ Address: \_\_\_\_\_ Phone No. \_\_\_\_\_

Trade Name: \_\_\_\_\_ Model No. \_\_\_\_\_

Installer: \_\_\_\_\_ Address: \_\_\_\_\_ Phone No. \_\_\_\_\_

History:  New Product  2-5 years old  5-10 years old  More than 10 years old

Differences between proposed substitution and specified product: \_\_\_\_\_

Point-by-point comparative data attached – REQUIRED

Undersigned certifies:

- Proposed substitution has been fully investigated and determined to be equal or superior in all respects to specified product.
- Same warranty will be furnished for proposed substitution as for specified product.
- Same maintenance, service, and availability of replacement parts, as applicable, are available.
- Proposed substitution will not affect or delay Progress Schedule, except as stated below.
- Cost data as stated above is complete. Claims for additional costs related to accepted substitution which may subsequently become apparent are to be waived.
- Proposed substitution does not affect dimensions and functional clearances, except as stated below.
- Payment will be made for changes to building design, including architectural or engineering design, detailing, licenses, royalties, and construction costs caused by the requested substitution.
- Coordination, installation, and changes in the Work as necessary for accepted substitution will be completed in all respects.

Reason for not providing specified item: \_\_\_\_\_

Similar Installation:

Project: \_\_\_\_\_

Design Professional: \_\_\_\_\_

Address: \_\_\_\_\_

Owner: \_\_\_\_\_

Date Installed: \_\_\_\_\_

Proposed substitution affects other parts of Work:  No  Yes; explain \_\_\_\_\_

Savings to Owner for accepting substitution: \_\_\_\_\_

Proposed substitution changes Contract Time:  No  Yes; add/deduct \_\_\_\_\_ days.

Supporting Data Attached:

Product Data  Drawings  Tests  Reports  Samples  \_\_\_\_\_

Attachments: \_\_\_\_\_

---

---

---

---

Submitted by: \_\_\_\_\_

Signature: \_\_\_\_\_

Firm: \_\_\_\_\_

Address: \_\_\_\_\_

Telephone: \_\_\_\_\_ Fax: \_\_\_\_\_ E-Mail: \_\_\_\_\_

---

---

---

---

Additional Comments:  Contractor  Subcontractor  Supplier  Manufacturer  DP  \_\_\_\_\_

**DESIGN PROFESSIONAL'S REVIEW AND ACTION**

- Substitution approved – Make submittals in accordance with Specification Section 01300.
- Substitution approved as noted – Make submittals in accordance with Specification Section 01300.
- Substitution rejected – Use specified materials.
- Substitution Request received too late – Use specified materials.

Signed by: \_\_\_\_\_ Date: \_\_\_\_\_

- 
- Distribution:
- Owner
  - Design Professional
  - Contractor
  - Consultant
  - Construction Manager
  - Other

**SECTION 01700**  
**TRAFFIC REGULATIONS**

**PART 1 GENERAL**

**1.1 Section Description**

- A. This section provides for the control and maintenance of traffic areas throughout the Work.

**1.2 Section Includes**

- A. Notification
- B. Maintenance of Traffic
- C. Traffic Control
- D. Signs
- E. Vehicle Parking
- F. Flagmen
- G. Lights
- H. Haul Routes
- I. Street Closure

**1.3 Related Sections**

- A. Section 01000 – General Requirements

**1.4 Notification**

- A. Advance written notice of construction activity shall be made to all adjacent residents no less than forty-eight (48) hours, or more than seventy-two (72) hours, before construction begins.
- B. The notice shall describe the activity anticipated in that area, the duration, and the effects upon the residents (such as restricted parking).
- C. The Contractor's on-site contact person, address, and direct telephone number shall be included, in addition to a contact person from City.

**1.5 Maintenance of Traffic**

- A. Traffic shall be maintained through construction, in accordance with the City of Kansas City, Public Works Department Standard Details and the Missouri Department of Transportation ( MoDOT) requirements within state right-of-way.
- B. The Contractor is responsible for maintaining traffic.
- C. The Contractor shall conduct his work so as to minimize interference with traffic, vehicular or pedestrian.
- D. A permit is required from the KCMO Public Works Department, Street and Traffic Division for areas where traffic will be obstructed in Kansas City, Missouri and from MoDOT for areas within MoDOT right-of-way. Contractor shall prepare traffic control plans for the Work and submit to KCMO and MoDOT for traffic control permits.
- E. When necessary to cross or interfere with traffic the Contractor shall provide and maintain suitable and safe bridges, detours, or other temporary expedients for the accommodation of public and private travel. Contractor shall give at least twenty-four (24) hours notice to owners of private drives before interfering with them.
- F. Contractor shall seek approval from MoDOT for any lane closures on state routes. The lane closure request and temporary traffic control plan shall be submitted to MoDOT for review and approval at least two working days prior to the planned closure.

## **1.6 Traffic Control**

- A. General
  - 1. All streets, roads, highways, and other public thoroughfares that are to be temporarily closed or restricted to traffic shall be protected by effective barricades on which shall be placed acceptable warning signs. Barricades shall be located at the nearest intersecting public highway or street on each side of the blocked section.
  - 2. All open trenches and other excavations shall be covered with steel plates and have suitable barricades, signs, and lights to provide adequate protection to the public. Obstructions such as material piles and equipment shall be provided with similar warning signs and lights.
  - 3. All barricades and obstructions shall be illuminated with warning lights from sunset to sunrise. Material storage and performance of the Work on or alongside public streets and highways shall minimize obstruction and inconvenience to the public.
  - 4. All barricades, signs, lights, and other protective devices shall be installed and maintained in conformity with applicable statutory requirements and, where within railroad and highway rights-of-way, as required by the authority having jurisdiction.

5. Working hours on traveled roadways or within the clear zone are typically limited to 9:00 a.m. to 4:00 p.m. Monday through Friday. However, due to the proximity of schools and high volume of traffic additional restrictions on working hours may be required by the KCMO Public Works Department or MoDOT. Contractor shall schedule work around working hour restrictions.
6. The Contractor shall maintain a minimum of one lane of traffic in all directions at all times. No more than 660 feet of lane length can be restricted at a single time unless otherwise specified in the traffic control permit.

**B. Devices:**

1. Contractor shall provide all barricades, cones, construction warning signs, flagmen, and incidental devices to protect personnel and equipment on the Work site.
2. Contractor shall display the required signs. Traffic control devices not in use shall be covered, removed, or turned away from view of oncoming traffic. Whenever the work area changes, all construction warning signs and traffic channelization devices shall be made current in both legend and function.
3. Contractor shall provide "Temporary Traffic Control" that is in accordance with the minimums set forth in the "Manual on Uniform Traffic Control Devices for Streets and Highways" (MUTCD( - Current Edition. Substitutions for the required devices and methods will only be allowed with the written approval of the KCMO Public Works Department, Street and Traffic Division or MoDOT.

**C. Non-work hours:**

1. During non-work hours all roadways shall be opened to normal traffic.
2. Construction equipment or materials shall not interfere with traffic during non-work hours. Barricades (barrels, type I) equipped with appropriate warning lights shall be placed adjacent to the work area. Construction signs, except "ROAD CONSTRUCTION AHEAD" signs, shall be covered or turned from view of oncoming traffic.

## **1.7 Signs**

**A. No Parking:**

1. "Emergency No Parking" signs may be installed at locations approved by KCMO Public Works Department or MoDOT within state right-of-way.
2. Signs shall be in accordance with the KCMO Public Works "Standard Signs for Traffic Maintenance During Construction" or MoDOT requirements. Signs shall be on aluminum or plywood panels. Paper or cardboard signs will not be allowed. Signs must be installed a minimum of eighteen (18) hours prior to beginning Work. The Contractor must contact the Public Works Dispatcher (816-513-9300) as soon as the signs are installed so that the KCMO Police

Department can be notified. The signs cannot be enforced without this notification to City and KCMO Public Works Department.

3. Signs shall be installed on either steel driven posts or existing utility poles at a height of five (5) feet from the bottom of the sign. The signs are to be installed at 150-foot intervals. The Contractor shall immediately remove all signs and covers as soon as work has been completed. If work will cease for more than seventy-two (72) hours, the signs and covers shall be removed and reinstalled subject to the minimum eighteen (18) hours notice.

## **1.8 Vehicle Parking**

- A. Parking of construction vehicles and personal vehicles of Contractor's personal shall not interfere with public traffic and parking, access by emergency vehicles, and City operations.

## **1.9 Flagmen**

- A. Contractor shall provide trained and equipped flagmen to regulate traffic when construction operations or traffic encroach on public traffic lanes.

## **1.10 Lights**

- A. Contractor shall use lights during hours of low visibility to delineate traffic lanes and to guide traffic.

## **1.11 Haul Routes**

- A. Contractor shall consult with City and KCMO Public Works Department or MoDOT within state right-of-way to establish public thoroughfares to be used for haul routes and site access.

## **1.12 Street Closure**

- A. Contractor shall obtain a Street Closure Permit in advance of a proposed closure date.

## **PART 2 PRODUCTS**

1. Not Used

## **PART 3 EXECUTION**

### **3.1 Coordination**

- A. Damages:
  1. Damage to existing roads and utilities during the Work that requires immediate repair may be considered an "emergency". Therefore, Contractor shall immediately contact the utility, the KCMO Public Works Department,

Street and Traffic Division or MoDOT within state right-of-way whenever there is damage that may require immediate repair. Such repair work once declared an “emergency” will be pursued on a continuous (around the clock) basis until complete or advanced to such a point that use of the roadway can be returned to normal operation and any subsequent repairs completed during normal working hours.

**B. Adjustments:**

1. The KCMO Public Works Department, Street and Traffic Division or MoDOT within state right-of-way reserves the right to make adjustments or revisions in traffic handling requirements that may become necessary after the Work has started. These changes will be determined on the basis of periodic inspections throughout the duration of the Work.
2. Notice of such change will be transmitted to the Contractor and it will be his responsibility to make the necessary changes as soon as practicable after receipt of the notification.

### **3.2 Inspections and Maintenance**

**A. Inspections:**

1. The Contractor shall make periodic inspections of the traffic control devices installed as part of Work and shall maintain record of any maintenance required. These records will be maintained throughout the Work and be incorporated as part of the final records.
2. The Contractor shall make daily inspections of the traffic control devices installed.

**B. Maintenance:**

1. Contractor shall be required to designate a specific employee to be responsible for the maintenance of the traffic control devices and establish a method of contacting this person. This information shall be provided to City, the KCMO Public Works Department, Street and Traffic Division, and MoDOT, in writing prior to the start of work.
2. Contractor may, at his option, establish a maintenance agreement with a qualified firm, approved by City, to supply, install and maintain the required traffic control devices throughout the duration of the Work.
3. Whenever the work area changes, all construction warning signs and traffic channelization devices shall be made current in both legend and function.
4. The roadway shall be kept clean and free of construction related debris at all times.

### **3.2 Payment**

- A. No separate payment will be made for the Traffic Control Permits or the maintenance or control of traffic. Contractor shall include in his Total Bid Price all labor, materials, and equipment for the maintenance and control of traffic for his Work and permit costs.

END OF SECTION



## SECTION 02200M – EARTHWORK

### PART 1 - GENERAL

#### 1.01 SUMMARY

- A. This section covers earthwork associated with general excavation, backfill and compaction required for the Work associated with maintenance activities.
- B. This section also covers the handling, storage, transportation and disposal of all excavated material; sheeting and shoring, subgrade preparation, dewatering as necessary or required, protection of adjacent property, construction of fills and embankments, surfacing and grading; and other appurtenant work.
- C. Additional requirements for excavation, backfill and compaction for trenching can be found in Section 02250M – Trenching, Pipe Embedment and Backfill.

#### 1.02 SPECIFICATION MODIFICATIONS

- A. It is understood that throughout this section these Specifications may be modified by appropriate items in Section 01015 – Specific Project Requirements.

#### 1.03 RELATED SECTIONS

- A. Section 00700 – General Conditions.
- B. Section 01000 – General Project Requirements.
- C. Section 01015 – Specific Project Requirements.
- D. Section 02250M – Trenching, Pipe Embedment and Backfill.
- E. Section 02575M – Surface Restoration

#### 1.04 CODES AND STANDARDS

- A. The publications listed below form a part of this specification to the extent referenced. The publications are referred to within the text by the basic designation only.
- B. American Society for Testing and Materials (ASTM):
  - ASTM D698 Standard Test Methods for Laboratory Compaction Characteristics of Soils Using Standard Effort (12,400 ft-lbf/ft<sup>3</sup>).
  - ASTM D1556 Standard Test Method for Density and Unit Weight of Soil in Place by Sand-Cone Method.
  - ASTM D2167 Standard Test Method for Density and Unit Weight of Soil in Place by the Rubber Balloon Method.
  - ASTM D4318 Standard Test Methods for Liquid Limit, Plastic Limit and Plasticity Index of Soils.
  - ASTM D4546 Standard Test Method for One-Dimensional Swell or Collapse of Soils.
  - ASTM D6938 Standard Test Method for In-Place Density and Water Content of Soil and Soil-Aggregate by Nuclear Methods (Shallow Depth).
- C. City of Kansas City, Missouri Department of Public Works, Construction and Material Specifications (<http://kcmo.gov/publicworks/design-construction-standards/>) KCMO PW 2202, Subsection 2202, Untreated Compacted Aggregate.
- D. Kansas Department of Transportation, Standard Specification and Construction Manual, Division 1100, Aggregates.

- E. Missouri Department of Transportation, Missouri Standard Specifications for Highway Construction, Division 1000, Materials Details.

1.05 DEFINITIONS

- A. Paved Areas – Areas for which the final surfacing will be street pavement, shoulders, driveways, parking lots, curbs, gutters, sidewalks, gravel roads or other surface features.
- B. Unpaved Areas – Areas for which the final surfacing will be in a green space.

1.06 INFORMATION PROVIDED BY THE CITY

- A. As provided in the Contract Documents.

1.07 QUALITY ASSURANCE

- A. The Contractor is responsible for the quality assurance and quality control of the Work.
- B. Sampling and Testing:
  - 1. Tests to determine conformance with all requirements of this Specification for quality and properties of all Contractor-secured materials, including borrow materials proposed for use, shall be performed by an independent, state-certified, commercial laboratory retained and compensated by the Contractor and approved by the City/Design Professional.
  - 2. All work associated with QUALITY ASSURANCE shall be included in the Bid Price and will be incidental to the Work. No separate measurement or payment will be made.

1.08 PRODUCT DELIVERY, STORAGE AND HANDLING

- A. The City will furnish the Site in accordance with Section 00700 – General Conditions.
- B. See Section 01000 – General Project Requirements, paragraph EASEMENTS AND RIGHT-OF-WAY for use of private property for delivery, storage and handling.
- C. Perform in a manner to prevent contamination or segregation of materials.

1.09 EXISTING UTILITIES

- A. The Contractor shall notify utilities prior to excavation in accordance with Section 00700 – General Conditions, Article 6 – Contractor’s Responsibilities, paragraph NOTIFICATION OF UTILITIES.
- B. Movement of construction machinery and equipment over pipes and utilities during construction is at the Contractor's sole risk.
- C. For work immediately adjacent to or for excavations exposing a utility or other buried obstruction, excavate by hand, start hand excavation on each side of the indicated obstruction and continue until the obstruction is uncovered or until clearance for the new grade is assured.
- D. Support uncovered lines or other existing work affected by the excavation until approval for backfill is granted by the City.
- E. Report damage to utility lines or subsurface construction immediately to the City.

## PART 2 - PRODUCTS

### 2.01 MATERIALS ENCOUNTERED

- A. Suitable Materials – Materials suitable for use in backfill, fill and embankment include job excavated or borrow material that is free of debris, roots, organic matter, frozen matter and shale particles/rock/stone or gravel with all dimensions less than 2 inches:
  - 1. Cohesion-less materials include gravels, gravel-sand mixtures, sands and gravelly sands; generally exclusive of clayey and silty material with the following properties:
    - (a) Free-draining.
    - (b) Impact compaction will not produce a well-defined moisture-density relationship curve.
    - (c) Maximum density by impact methods will generally be less than by vibratory methods.
    - (d) Generally less than 15% by dry weight of soil particles pass a No. 200 sieve.
  - 2. Cohesive materials include materials made up predominately of silts and clays generally exclusive of sands and gravel with the following properties:
    - (a) Impact compaction will produce a well-defined moisture-density relationship curve.
    - (b) Are not free draining.
- B. Unsuitable Materials – Materials unsuitable for use in backfill, fill and embankment include all material that contains debris, roots, organic matter, frozen matter, shale particles/rock/stone or gravel with any dimension greater than 2 inches. Additionally, as determined by the City/Design Professional, any other materials that are too wet or otherwise unsuitable for providing a stable subgrade or stable foundation for structures or trenches.
- C. Material used for embankment or fill:
  - 1. For soils used below structural elements (such as: footings, slabs, pavements and mats), the portion of material passing the No. 40 sieve shall have a liquid limit not exceeding 40 and a plasticity index not exceeding 25 when tested in accordance with ASTM D4318.

### 2.02 TOPSOIL

- A. On-Site Topsoil – Surface soil stripped and stockpiled on site and modified as necessary to meet the requirements specified herein. When available, topsoil must be existing surface soil stripped and stockpiled on the Site.
- B. Off-Site Topsoil – Conform to requirements specified herein. Additional topsoil must be furnished by the Contractor.
- C. Composition – Natural, friable soil representative of productive, well-drained soils in the area, free of subsoil, stumps, rocks larger than 1- inch diameter, brush, weeds, toxic substances and other material detrimental to plant growth. Amend topsoil pH range to obtain a pH of 5.5 to 7.
- D. Topsoil shall be of a quality at least equal to the existing topsoil in adjacent areas, free from trash, stones, debris and well suited to support plant growth.

### 2.03 WASTE MATERIALS

- A. Waste materials, as described for purposes of this Section, consist of unsuitable materials such as: rock, surplus excavated material, demolition debris and other materials considered unacceptable for use as fill.

- B. Waste materials shall not include environmental pollutants, hazardous substances, contaminated products, by-products, samples or waste materials of any kind that are regulated under environmental laws.

2.04 BORROW MATERIALS

- A. Suitable fill materials, granular materials and topsoil obtained from locations arranged for by Contractor (off the Site) are required to the extent sufficient suitable materials cannot be obtained from excavation and trenching.
- B. Borrow materials shall not exhibit characteristics of high shrink or swell potential as determined from Atterberg limit tests (ASTM D4318) and/or swell tests (ASTM D4546) unless otherwise specified herein.

2.05 GRANULAR FILL MATERIAL

- A. Granular fill material shall consist of crushed stone, sand and gravel or reclaimed asphalt or concrete. The aggregate shall not contain more than 15 percent deleterious rock and shale. The fraction passing the No. 40 sieve shall have a plasticity index not to exceed six. Any sand, silt, clay and any deleterious rock and shale shall be uniformly distributed throughout the material.
- B. Reclaimed asphalt or concrete materials meeting the requirements of aggregate must be approved for use by the City.
- C. Granular fill material shall be in accordance with the following gradation requirements defined in Table 1 below:

**Table 1. Gradation for Granular Fill Material**

Sieve Size	Mass Percent Passing		
	MoDOT Type 5	KDOT Type AB-3	KCMO PW 2202**
2 inch		100	
1 ½ inch		95 to 100	
1 ¼ inch			100
1 inch	100		72 to 100
¾ inch		70 to 95	60 to 90
½ inch	60 to 90		
3/8 inch			43 to 74
No. 4	35 to 60	40 to 65	28 to 60
No. 8		30 to 55	
No. 10			16 to 40
No. 30	10-35		
No. 40		16 to 40	3 to 22
No. 200	0-15	8 to 20*	0 to 15**
* For Type AB-3, the fraction passing the No. 200 sieve shall not exceed ¾ of the fraction passing the No. 40 sieve.			

**Table 1. Gradation for Granular Fill Material**

Sieve Size	Mass Percent Passing		
	MoDOT Type 5	KDOT Type AB-3	KCMO PW 2202**
** For KCMO PW 2200, the difference between Mass Percent Passing of successive sieve sizes shall not exceed 25%. That fraction of material passing the No. 40 sieve shall have a plasticity index not to exceed 8.			

1. MoDOT Type 5 material shall conform to Missouri Department of Transportation, Standard Specifications for Highway Construction, Section 1007, Type 5 Aggregate.
2. KDOT Type AB-3 material shall conform to Kansas Department of Transportation, Standard Specification and Construction Manual, Division 1100, Aggregates.

2.06 CONTROLLED LOW STRENGTH MATERIAL (CLSM)

- A. See Section 02250M – Trenching, Pipe Embedment and Backfill.

PART 3 - EXECUTION

3.01 GENERAL REQUIREMENTS FOR OPEN EXCAVATIONS

- A. Excavations shall be restored to the level of the adjacent surfaces as soon as practicable.
- B. Unsupervised or unprotected excavations are prohibited. The Contractor shall adhere to the City’s no open excavation policy.
- C. Protective Measures in Paved Areas:
  1. Excavations within paved areas shall be protected and secured in accordance with existing federal, state and local codes and standards. This includes, but not limited to, the most current edition of the Manual of Uniform Traffic Control Devices.
- D. Protective Measures Unpaved Areas:
  1. Supervision – As a temporary measure, the Contractor may provide personnel to supervise an open excavation that is not otherwise protected. Supervision shall ensure that the public is protected and shall serve the same function as a protective cover or fencing. A protective cover or fencing shall be installed for all excavations that are not supervised.
  2. Protective Cover – A protective cover shall be installed over the excavation so that it can sustain the weight of any persons and/or objects placed upon it. The cover shall be of sufficient weight or fixed to the ground so it cannot be moved. Protective covers shall have no opening(s) or protuberance(s) of sufficient size to cause a fall or injury. Advance warning devices shall be installed as required by the City/Design Professional.
  3. Fencing – Any excavation that is not covered shall be fenced in so that it surrounds the entire excavation area and prevents entry. The fencing shall be a

minimum of 42 inches in height. The fence shall be secured and upright at all times.

- E. Inspection and Maintenance – Protective measures (coverings and fences) shall be inspected by the Contractor at least daily to assure integrity. Protective measures in heavy traffic areas shall be inspected more often as necessary.
- F. Excavation permits shall be secured prior to starting the work.

### 3.02 EXCAVATION

- A. Excavations shall provide adequate working space and clearances for the work to be performed therein and for installation and removal of concrete forms.
- B. In no case shall excavation faces be undercut for extended footings.
- C. Subgrade surfaces shall be clean and free of loose material of any kind when concrete is placed thereon.
- D. Classification of Excavated Materials – No classification of excavated materials will be made. Excavation and trenching work shall include the removal and subsequent handling of all materials excavated or otherwise removed in performance of the work, regardless of the type, character, composition or condition thereof.

### 3.03 BLASTING

- A. Unless otherwise noted in Section 01015 – Specific Project Requirements, blasting or other use of explosives for excavation will not be permitted.

### 3.04 DEWATERING

- A. Dewatering equipment shall be provided to remove and dispose of all surface water and groundwater entering excavations, trenches or other parts of the Work.
- B. To prevent damage from hydrostatic pressure, flotation or other cause, all excavations shall be protected and kept dry during subgrade preparation and continually thereafter until the structure is built or the pipe is installed and the area is backfilled.
- C. All excavations for concrete structures or trenches which extend down to or below groundwater shall be dewatered by lowering and keeping the groundwater level beneath such excavations 12 inches or more below the bottom of the excavation.
- D. Surface water shall be diverted or otherwise prevented from entering excavations or trenches to the greatest extent possible without causing damage to adjacent property.
- E. If the material within the excavation becomes unsuitable or unstable as a result of the Contractor's inability to implement adequate surface diversion or dewatering measures, then the Contractor shall remove unsuitable materials and replace with approved compacted fill material as directed by City and at no additional cost to the City.
- F. Surface water and groundwater that contains silt and soil shall not be disposed of without pre-treatment.
- G. The Contractor is responsible for the condition of any pipe, conduit or drainage way which is utilized for drainage purposes. Any such pipe, conduit or drainage way utilized shall be left clean and free of sediment.

### 3.05 SHEETING AND SHORING

- A. The Contractor shall provide all shoring, bracing, cribbing, trench boxes, underpinning and sheeting as necessary to support excavations.
- B. The Contractor shall provide a Sheeting and Shoring Plan that includes provisions that will accomplish the following:

1. Prevent undermining of pavements, foundations and slabs.
2. Prevent slippage or movement in banks or slopes adjacent to the excavation.
3. Allow for the abandonment of shoring and sheeting materials in place in critical areas as the Work is completed. In these areas, backfill the excavation to within 3 feet of the finished grade and remove the remaining exposed portion of the shoring before completing the backfill.
4. Except where banks are cut back on a stable slope, excavations for structures shall be supported as necessary to prevent caving or sliding.
5. Excavations shall provide adequate working space and clearances for the Work to be performed.
6. Undercutting of excavation faces is prohibited.

### 3.06 BACKFILL AND COMPACTION

- A. See Section 02250M – Trenching, Pipe Embedment and Backfill for additional requirements.
- B. Weather Limitations – Construction of fills and embankments during freezing weather shall not be done except by permission of the City/Design Professional. No fill or embankment materials shall be installed on frozen surfaces, nor shall froze material, snow or ice be placed in the fill or embankment.
- C. To the extent possible, excess suitable material obtained from trench excavation can be used for the construction of fills and embankments. Additional material shall be provided as required.
- D. After preparation of the fill or embankment site, the subgrade shall be leveled and rolled so that surface materials of the subgrade will be compacted and well bonded with the first layer of the fill or embankment and for subsequent layers.
- E. All fill and embankment materials shall be placed in layers not to exceed 8 inches in un-compacted thickness.
- F. Material deposited in piles or rows by excavating and hauling equipment shall be spread and leveled before compacting.
- G. No shale particles, rock, gravel or stone with any dimension greater than 2 inches shall be placed in the upper 18 inches of any fill or embankment. Rocks or stones within the allowable size limit may be incorporated in the remainder of fills and embankments, provided they are distributed so that they do not interfere with proper compaction.
- H. The material in each layer shall be wetted or dried as required and thoroughly mixed to ensure uniform moisture content and adequate compaction. Each layer shall be thoroughly compacted as follows:
  1. Unpaved Areas:
    - (a) 90% of maximum dry density at moisture content range from 3% below optimum to 2% above optimum as determined by ASTM D698.
    - (b) If the material fails to meet the density specified, compaction methods shall be altered.
  2. Paved Areas:
    - (a) All subgrades below paved area and within 1 foot of a paved areas shall be compacted to 95% of maximum dry density at moisture content range from 3% below optimum to 2% above optimum as determined by ASTM D698 for the subgrade 1 foot outside of paved areas.
    - (b) If the material fails to meet the density specified, compaction methods shall be altered.

3. Project specific requirements for backfill and compaction may be modified in Section 01015 – Specific Project Requirements.
- I. Trenches in Embankments – Wherever a trench is to pass through a fill or embankment, the fill or embankment material shall be placed and compacted to an elevation not less than 36 inches above the top of pipe elevation before the trench is re-excavated.
- J. Trenches and pipes that pass through a water-containing embankment shall eliminate the granular embedment material and the trench bottom shall be graded to provide uniform and continuous support for the pipe. The pipe shall be embedded in embankment material containing no rocks, stones or other pervious material. The embedment material shall be compacted as specified for the embankment.

### 3.07 GRANULAR FILLS

- A. See Section 02250M – Trenching, Pipe Embedment and Backfill for additional requirements.
- B. Granular fill material shall be provided where indicated by City.
- C. Granular fill material shall be placed on suitably prepared subgrades and compacted by vibration.
- D. Backfill and Compaction – The material in each layer shall be wetted or dried as required and thoroughly mixed to ensure uniform moisture content and adequate compaction. Each layer shall be thoroughly compacted with a vibratory compactor to 95% of maximum dry density at moisture content range from 3% below optimum to 2% above optimum as determined by ASTM D698.
- E. If the material fails to meet the density specified, compaction methods shall be altered.
- F. Where granular fills are to be covered with concrete, the top surface shall be graded to the required subgrade.

### 3.08 FIELD QUALITY CONTROL

- A. See Section 02250M – Trenching, Pipe Embedment and Backfill for additional requirements.
- B. Compaction Tests:
  1. Two initial gradation tests shall be made for each type of embedment, fill and backfill material used and one additional gradation test shall be made for each additional 500 tons of each material. At the sole expense of the Contractor, moisture-density (Proctor) tests, relative density tests on the materials and all in-place field density tests shall be performed by the Contractor. All tests performed shall be done in accordance with ASTM D698.
  2. The method of in-place compaction testing including density and moisture content shall be as follows:
    - (a) Density - Cohesive materials: ASTM D2167, ASTM D1556 or ASTM D6938.
    - (b) Density - Cohesion-less materials: ASTM D6938.
    - (c) Moisture Content: ASTM D6938.
  3. The minimum frequency of in-place compaction testing including density and moisture content will be as follows:
    - (a) At least one test for every 2,000 cubic yards of material placed in a mass fill.
    - (b) At least one test when the City suspects the quality of moisture control or effectiveness of compaction.



4. Any material/fill failing to meet required densities shall be removed, replaced and compacted as necessary to achieve specified results.
5. Removal of in-place material and replacement with approved new material will be required if scarifying and re-compaction do not produce the required densities.

### 3.09 EQUIPMENT

- A. The Contractor shall utilize appropriate equipment to obtain the compaction requirements specified. Acceptable equipment includes, but is not limited to, the following:
  1. Tamping Rollers.
  2. Pneumatic Rollers.
  3. Vibratory Rollers.
  4. Other methods that have been tested and have been shown to meet the specified compaction rates.
- B. Power tampers or rammers shall be used for the compaction of material in areas where it is impractical or unsafe to use heavy equipment or as recommended by the City.
- C. Vibratory plate compactors, manual or attached to excavation equipment, may be used for consolidation of embedment and compaction of granular fill in areas where it is impractical or unsafe to use heavy equipment or as recommended by the City.
- D. All compaction equipment is subject to the approval of the City/Design Professional.

### 3.10 FINAL GRADING AND PLACEMENT OF TOPSOIL

- A. After all trenching, backfilling, compaction and embankments to be constructed have been rough graded, all areas shall be final graded to the indicated elevations, slopes and contours.
- B. All cuts, fills, embankments and other areas which have been disturbed or damaged by construction operations shall be surfaced with at least 6 inches of topsoil to meet final grade.
- C. Use of graders or other power equipment will be permitted for final grading and dressing slopes, provided the result is uniform and equivalent to manual methods.
- D. All surfaces shall be graded to provide effective drainage. Unless otherwise indicated, a slope of at least 1 percent shall be provided.
- E. Final grade shall be smooth, even and free from clods, rocks, stones, weeds, brush and other debris.

### 3.11 DISPOSAL OF EXCESS EXCAVATED MATERIALS

- A. Except as otherwise permitted, all excess excavated materials shall be disposed of off-site.
- B. Rock – Excavated rock in excess of the amount permitted to be installed in trench backfill (see Section 02250M – Trenching, Pipe Embedment and Backfill) shall be disposed of off-site.
- C. Other Debris – Waste material and other debris encountered in during excavation shall be disposed of off-site.
- D. The disposal of waste and surplus excavated materials, including hauling, handling and grading is incidental to Earthwork. No separate measurement or payment shall be made.

3.12 SEEDING AND SODDING

- A. All areas disturbed by the Contractor's operations shall be seeded or sodded according to the requirements of Section 02575M – Surface Restoration.

3.13 SETTLEMENT

- A. The Contractor is solely responsible for all settlement which may occur within the correction period (as stipulated in the General Conditions and Supplementary Conditions). Within 30 days after notice from the City, the Contractor shall make all settlement repairs and the associated restoration caused by correcting the settlement.

END OF SECTION

## **SECTION 02250 – TRENCHING, PIPE EMBEDMENT AND BACKFILL**

### **PART 1 - GENERAL**

#### **1.01 SUMMARY**

- A. This section specifies requirements for trench excavation, pipe embedment, backfill and compaction for the installation of water, sanitary sewer and storm water piping.

#### **1.02 SPECIFICATION MODIFICATIONS**

- A. It is understood that throughout this section these Specifications may be modified by appropriate items in Section 01015 – Specific Project Requirements or as otherwise modified in the Contract Documents.

#### **1.03 RELATED SECTIONS**

- A. Section 01000 – General Project Requirements.
- B. Section 01015 – Specific Project Requirements.
- C. Section 02180 – Clearing and Grubbing.
- D. Section 02190 – Demolition.
- E. Section 02200 – Earthwork.
- F. Section 02230 – Geotextiles.
- G. Section 02575 – Surface Restoration.
- H. Section 02930 – Seeding.
- I. Section 02931 – Sodding.

#### **1.04 CODES AND STANDARDS**

- A. The publications listed below form a part of this specification to the extent referenced. The publications are referred to within the text by the basic designation only.
- B. American Society for Testing and Materials (ASTM):
  - ASTM C33 Standard Specification for Concrete Aggregates.
  - ASTM C150 Standard Specification for Portland Cement.
  - ASTM C494 Standard Specification for Chemical Admixtures for Concrete.
  - ASTM C618 Standard Specification for Coal Fly Ash and Raw or Calcined Natural Pozzolan for Use in Concrete.
  - ASTM C940 Method of Determination of Purity by Measurement of Freezing Points.
  - ASTM C1602 Standard Specification for Mixing Water Used in the Production of Hydraulic Cement Concrete.
  - ASTM D698 Standard Test Methods for Laboratory Compaction Characteristics of Soils Using Standard Effort (12,400 ft-lbf/ft<sup>3</sup>).
  - ASTM D4253 Standard Test Methods for Maximum Index Density and Unit Weight of Soils Using a Vibratory Table.
  - ASTM D4254 Standard Test Methods for Minimum Index Density and Unit Weight of Soils and Calculation of Relative Density.
  - ASTM D4318 Standard Test Methods for Liquid Limit, Plastic Limit and Plasticity Index of Soils.

ASTM D4832	Standard Test Method for Preparation and Testing of Controlled Low Strength Material (CLSM) Test Cylinders.
ASTM D6938	Standard Test Method for In-Place Density and Water Content of Soil and Soil-Aggregate by Nuclear Methods (Shallow Depth).

#### 1.05 DEFINITIONS

- A. Paved Areas – Areas for which the final surfacing will be traffic-bearing surface treatments such as street pavement, shoulders, driveways, parking lots, curbs, gutters, gravel roads or other surface treatments for traffic (pavers, etc...). Sidewalks and trails are excluded from the definition.
- B. Unpaved Areas – Areas for which the final surfacing will not be a Paved Area.
- C. Downtown Loop – The area of the city bounded on the north by Interstate 70, on the east by U.S. 71, on the south by Interstate 670 and on the west by Interstate 35.

#### 1.06 INFORMATION PROVIDED BY THE CITY

- A. As provided in the Contract Documents.

#### 1.07 SUBMITTALS

- A. Submit as specified in Section 01300 – Submittals.
- B. Shop Drawings:
  - 1. Sheeting and Shoring Design – Contractor shall submit, in accordance with 29 CFR Part 1926 - OSHA Subpart P - Excavations and Trenches, a shoring design sealed by a registered professional engineer in the State of Missouri for all excavations greater than twenty (20) feet in depth prior to excavation. Submittal will be for informational purposes only.
- C. Testing Reports:
  - 1. Laboratory testing results for proposed Borrow Materials.
  - 2. Laboratory testing results and quarry control reports for Granular Material.
  - 3. Laboratory testing results for and quarry control reports Granular Bedding.
  - 4. Laboratory testing results for compression testing of CLSM.
  - 5. Moisture-density (Proctor) test results.
  - 6. In-Place Density test results.
- D. Other Submittals:
  - 1. Commercial Laboratory – submit name, contact information and certification of the commercial testing laboratory required by paragraph QUALITY ASSURANCE.
  - 2. Mix Design for CLSM.
  - 3. Concrete Plant – submit the name and location of the concrete plant which will provide the CLSM.

#### 1.08 QUALITY ASSURANCE

- A. The Contractor is responsible for the quality assurance and quality control of the Work.
- B. Sampling and Testing:
  - 1. Tests to determine conformance with all requirements of this Specification and for the quality and properties of all Contractor provided materials, including borrow materials proposed for use. The aforementioned testing shall be performed by an independent, state-certified, commercial laboratory retained and compensated by the Contractor and approved by the City.

2. All work associated with QUALITY ASSURANCE shall be included in the Bid Price and will be incidental to the Work.

#### 1.09 PRODUCT DELIVERY, STORAGE AND HANDLING

- A. Stockpile materials in other areas or offsite when adjacent structures, easement limitations or other restrictions prohibit storage adjacent to the Work.
- B. Offsite areas shall be arranged for by the Contractor in accordance with Section 01000 – General Project Requirements.
- C. Granular fill and granular bedding material shall be stored so that it is protected from freezing and significant changes in moisture content.

### PART 2 - PRODUCTS

#### 2.01 MATERIALS ENCOUNTERED

- A. Suitable Materials – As defined by, Section 02200 – Earthwork, paragraph MATERIALS ENCOUNTERED.
- B. Unsuitable Materials – As defined by, Section 02200 – Earthwork, paragraph MATERIALS ENCOUNTERED.
- C. Topsoil – As defined by, Section 02200 – Earthwork, paragraph MATERIALS ENCOUNTERED.
- D. Rock – Unless otherwise specified in Section 01015 – Specific Project Requirements, all Materials encountered, regardless of type, character composition and condition shall be considered "unclassified" for the purpose of payment. Contractor shall determine the quantity of various materials to be excavated prior to submitting their Bid. Rock encountered shall be excavated at no extra cost to City.

#### 2.02 WASTE MATERIALS

- A. As defined by, Section 02200 – Earthwork, paragraph WASTE MATERIALS.

#### 2.03 BORROW MATERIALS

- A. As defined by, Section 02200 – Earthwork, paragraph BORROW MATERIALS.

#### 2.04 GRANULAR BEDDING

- A. Granular bedding for pipe bedding or embedment shall be clean crushed rock with not less than 95 percent passing a ½-inch sieve and not more than 5 percent passing a #No. 4 sieve. The gravel mixture shall contain no clay lumps or organic matter. The fraction passing the No. 4 sieve shall have a liquid limit not greater than 25 and a plasticity index not greater than 5 when tested in accordance with ASTM D4318.
- B. Granular bedding material shall contain no cinders, clay lumps or other material which may cause pipe corrosion.

#### 2.05 JOB EXCAVATED MATERIAL

- A. Material excavated from the trench.
- B. Meets the requirements of suitable material, except that it may include shale particles gravel or stone with any dimension up to 2 inches.

#### 2.06 GRANULAR FILL MATERIAL

- A. Granular Fill Material shall be as defined by, Section 02200 – Earthwork, paragraph GRANULAR FILL MATERIAL.

## 2.07 CONTROLLED LOW STRENGTH MATERIAL (CLSM)

### A. Materials:

1. Portland cement Type I or Type II conforming to ASTM C150.
2. Fly ash conforming to ASTM C618 for Class C.
3. Fine aggregate conforming to ASTM C33.
4. Water, clean and potable conforming to ASTM C1602.
5. Shrinkage compensation shall be proportioned in accordance with the manufacturer's recommendations and as tested by ASTM C940.
6. Admixtures for air entrainment or for other purposes shall conform to ASTM C494 or other appropriate standards referenced by the manufacturer. Admixtures shall only be used when specified in the Contract Documents.

### B. Mixture Design:

1. Mix design for CSLM shall meet the requirements of Kansas City Public Works Department Specification Section 2600, except that the maximum compressive strength shall be from 50 to 125 psi and shall be removable without using a breaker and without damaging the utility.
2. The unit weight of the CLSM shall be a maximum of 120 pounds per cubic foot.

### C. Quality Control:

1. CLSM material shall be provided from a City-approved concrete plant. Contractor shall submit name and location of plant to be used.
2. One set of cylinders for compressive strength testing shall be obtained once per day or for every 100 cubic yards of flowable backfill placed.
3. Cost for Quality Control shall be included in the Bid Price. No separate measurement or payment shall be made.

## 2.08 TOPSOIL

- A. Topsoil shall be as defined by Section 02200 – Earthwork.

## PART 3 - EXECUTION

### 3.01 DEMOLITION

- A. Demolition shall be conducted in accordance with Section 02190 – Demolition.
- B. Waste materials resulting from the cutting of pavement shall be considered demolition debris and disposed in accordance with Section 02190 – Demolition.

### 3.02 PAVEMENT REMOVAL AND RESTORATION

- A. See additional requirements in Section 01000 – General Requirements, paragraph CUTTING AND PATCHING.
- B. Public Right of Way:
  1. Kansas City, Missouri Public Works Department Standard Detail SR-1, Street Cut Restoration is hereby incorporated by reference.
  2. See Section 01015 – Specific Project Requirements for additional detail.
- C. Other Pavement Cut and Restoration:
  1. Removal and replacement on private property shall be done in accordance with paragraph STREET CUT RESTORATION.
  2. Pavement removal shall be no larger than necessary to provide adequate working space for the proper installation of pipe and appurtenances.
  3. Pavement removal for connections to existing lines or structures shall not exceed the extent necessary for their installation.

4. Where the trench parallels the length of concrete walks and the trench location is all or partially under the walk, the entire walk shall be removed and replaced. Where the trench crosses drives, walks, curbs or other hard surfaces, the hard surfaces shall be removed and subsequently replaced between existing joints or between saw cuts as specified for pavement.

D. Driveways:

1. Demolition and restoration of driveways will be as indicated in Section 01015 – Specific Project Requirements or as shown on the Drawings.

3.03 CLEARING AND GRUBBING

- A. Perform clearing and grubbing as indicated or as necessary to perform excavation or trenching.
- B. Clearing and grubbing shall conform to Section 02180 – Clearing and Grubbing.

3.04 STRIPPING

- A. Stripping shall conform to the requirements of Section 02200 – Earthwork, paragraph STRIPPING.

3.05 GENERAL REQUIREMENTS FOR OPEN EXCAVATIONS

- A. See Section 02200 – Earthwork for additional requirements on open excavations.

3.06 BLASTING

- A. Blasting is prohibited unless approved by the City. If approved, Blasting shall conform to the requirements of Section 02200 – Earthwork, paragraph BLASTING.

3.07 DEWATERING

- A. Dewatering of trench excavations shall conform to the requirements of Section 02200 – Earthwork, paragraph DEWATERING.

3.08 SHEETING AND SHORING

- A. Sheeting and shoring for trench excavations shall conform to the requirements of Section 02200 – Earthwork and as specified herein.
- B. Excavations shall provide adequate working space and clearances for the Work to be performed.
- C. In no case shall excavation faces be undercut for extended footings. Trench sheeting shall be removed only if the pipe strength is sufficient to carry trench loads based on the trench width to the back of sheeting. Trench sheeting shall not be pulled until backfilling is completed.
- D. With the written approval from the City, sheeting may be left permanently in the trench. Where trench sheeting is left in place, such sheeting shall not be braced against the pipe, but shall be supported in a manner which will preclude concentrated loads or horizontal thrusts on the pipe. Cross braces installed above the pipe to support sheeting may be removed after pipe embedment has been completed.

3.09 TRENCH EXCAVATION

- A. Classification of Excavated Materials – No classification of excavated materials will be made. Excavation and trenching work shall include the removal and subsequent handling of all materials excavated or otherwise removed in performance of the work, regardless of the type, character, composition or condition.

- B. No more trench shall be opened than is necessary to expedite the work. Except where tunneling is indicated on the Drawings, specified or permitted by the City, all trench excavation shall be open cut.
- C. Alignment, Grade and Minimum Cover:
  - 1. The alignment, grade and elevation of each pipeline shall be as indicated on the Drawings.
  - 2. Trenches for waterlines shall be excavated to a depth sufficient to provide a minimum of 42 inches of pipe cover. Sixteen inch and larger diameter water lines shall be installed with a minimum of 60 inches of pipe cover.
  - 3. Greater pipe cover depths may be necessary on vertical curves or to provide necessary clearance for air release vaults, existing pipes, conduits, drains, drainage structures or other obstructions.
- D. Limiting Trench Widths:
  - 1. Trenches shall be excavated to a width which will provide adequate working space and sidewall clearances for proper pipe installation, jointing and embedment. Minimum trench widths shall be as follows:

**Table 1. Ductile Iron Pipe (DIP) and Polyvinyl Chloride (PVC) Pipe and High-Density Polyethylene Pipe (HDPE)**

<b>Pipe Size (inches)</b>	<b>Min. Trench Width in Earth (inches)</b>	<b>Max. Trench Width in Earth (inches)</b>	<b>Min. Trench Width in Rock (inches)</b>
4	18	24	18
6	24	30	24
8	26	32	26
12	28	34	28
16	34	40	34
20	38	44	38
24	42	48	42
≥ 27	O.D. plus 24	O.D. plus 30	O.D. plus 24

O.D. = Outside Diameter

**Table 2. Prestressed Concrete Cylinder Pipe (PCCP) and Reinforced Concrete Pipe (RCP)**

<b>Pipe Size (inches)</b>	<b>Min. Trench Width in Earth (inches)</b>	<b>Max. Trench Width in Earth (inches)</b>	<b>Min. Trench Width in Rock (inches)</b>
16	36	44	36
20	40	50	40
24	44	56	48
≥ 27	2 * O.D.	(2 * O.D.) + 12	(2 * O.D.) - 12

O.D. = Outside Diameter



- E. Mechanical Excavation:
  1. The use of mechanical equipment will not be permitted in locations where its operation would cause damage to trees, buildings, culverts, adjoining property, utilities or other structures above or below ground. In all such locations, hand excavating methods shall be used.
  2. Mechanical equipment used for trench excavation shall be of a type, design and construction and operated so that the rough trench excavation bottom elevation can be controlled and that trench alignment is such that pipe, when accurately laid to the specified alignment will be centered in the trench with adequate sidewall clearance. Undercutting the trench sidewall to obtain sidewall clearance is not permitted.
- F. Excavation Below Pipe Subgrade – The trench bottom shall be over excavated below the proposed pipe, as indicated in 02250-1 and 02250-2 of this Section, to provide for the installation of granular embedment.
- G. Foundations in Trenches:
  1. Whenever unsuitable or unstable soil conditions are encountered, trench subgrades shall be over-excavated until the trench subgrade is suitable as determined by the City/Design Professional.
  2. Adjustments may be made in the Contract Price in accordance with the provisions of the General Conditions.
- H. Bell Holes:
  1. Bell holes shall provide adequate clearance for tools and methods used in installing pipe.
  2. No part of any bell or coupling shall be in contact with the trench bottom, trench walls or granular embedment when the pipe is jointed. Place embedment around the joint connection after joining the pipe.

### 3.10 TRENCH SUBGRADE

- A. Subgrades for trench bottoms shall be firm, dense and thoroughly compacted and consolidated.
- B. Protect and maintain the trench subgrade when natural suitable materials are encountered.
- C. Remove rock fragments and materials disturbed during excavation and stripped from trench walls.
- D. Subgrades shall be free from mud and muck and shall be sufficiently stable to remain firm and intact.

### 3.11 FOUNDATION

- A. Description – A foundation is necessary when the native soils are unsuitable. For such a condition, the trench shall be over-excavated and a layer of supportive material shall be placed and compacted to provide a firm foundation for the subsequent pipe embedment material.
- B. The Foundation layer is shown on 02250-1 and 02250-2.
- C. Subgrades for trench bottoms which are otherwise solid, but which become mucky on top due to construction operations, shall be reinforced with trench stabilization material.
- D. Material – If the trench foundation is an unsuitable foundation for the pipe, the Contractor shall submit a plan, to the City/Design Professional for review and approval, to include the proposed material to be used for the foundation.

- E. Layer Thickness – Unsuitable material shall be over-excavated until the trench subgrade is suitable as determined by the City/Design Professional.
- F. Bedding:
  - 1. Description – A layer of supportive compacted material to provide even support of the pipe at the grade indicated on the Drawings.
  - 2. The Bedding layer is shown on 02250-1 and 02250-2.
  - 3. Material – Granular Bedding.
  - 4. Layer Thickness:
    - (a) A minimum of 3 inches below the pipe or pipe bell when the pipe is placed on a foundation or suitable material.
    - (b) A minimum of 6 inches below the pipe or pipe bell when the pipe is placed on rock.

### 3.12 HAUNCHING

- A. Description – Extends from the bottom of the pipe to the spring line of the pipe. Haunching provides the most resistance to pipe deflection.
- B. The Haunching layer is shown on 02250-1 and 02250-2.
- C. Material – Granular Bedding.
- D. Layer Thickness – One half the outside diameter of the pipe or pipe bell.

### 3.13 INITIAL BACKFILL

- A. Description – Extends from the spring line of the pipe to a point above the top of the pipe.
- B. Bedding Material:
  - (a) Class A Bedding – Granular Bedding.

### 3.14 FINAL BACKFILL

- A. Description – The zone from the top of the Initial Backfill to the bottom of final surfacing.
- B. The Haunching layer is shown on 02250-1 and 02250-2.
- C. Material:
  - 1. Paved Areas within the Downtown Loop – For areas where the final surfacing is a paved area, the final backfill shall be Controlled Low Strength Material (CLSM).
  - 2. Paved Areas – For areas where the final surfacing is a paved area, the final backfill shall be Granular Fill Material. CLSM may be substituted for Granular Fill Material as approved by the City or as indicated in the Contract Documents.
  - 3. Unpaved Areas:
    - (a) For areas where the final surfacing is an unpaved area, the final backfill material shall be a suitable material.
    - (b) Where the pipe cover is 8 feet or more, job excavated material may be used as backfill if the following requirements are met:
      - (i) The final surfacing is unpaved.
      - (ii) The minimum clearance from the top of the initial backfill is 36 inches or 42 inches from the top of the pipe.
      - (iii) The job excavated material shall not be placed within 18 inches of the finished grade.
- D. Layer Thickness – Varies with pipe depth.

### 3.15 EMBEDMENT

- A. Class A Embedment shall be used for all pipes.

### 3.16 BACKFILL PLACEMENT

- A. Granular Bedding and Granular Fill Material shall be placed in lifts not exceeding 12 inches in loose thickness.
- B. Suitable Material shall be placed in lifts not exceeding 12 inches in loose thickness.
- C. Bedding – Bedding Granular bedding material shall be spread and the surface graded to provide a uniform and continuous support beneath the pipe at all points between bell holes or pipe joints. It is permissible to slightly disturb the finished subgrade surface by the withdrawal of the pipe sling or other lifting tackle.
- D. Haunches:
  - 1. After each pipe has been graded, aligned and placed in final position on the bedding material and shoved home, sufficient pipe embedment material shall be deposited and compacted by shovel slicing or chalking under the pipe haunches on each side of the pipe and back of the bell or end thereof to hold the pipe in proper position and alignment during subsequent pipe jointing and embedment operations.
  - 2. Care shall be taken to protect protective pipe coatings or wraps. If coating or wrapping is damaged, then the Contractor shall repair or replace the coating to the satisfaction of the City at no additional cost to the City.
  - 3. Haunching and initial backfill material shall be deposited uniformly and simultaneously on each side of the pipe to prevent lateral displacement.
- E. Weather Limitations – Backfilling of trenches during freezing weather shall not be done except by permission of the City. No backfill materials shall be installed on frozen surfaces, nor shall froze materials, snow or ice be placed in the trench.
- F. Pipe Encasements – A layer of backfill material not more than 8 inches deep may be placed over concrete arch encasement or concrete reaction blocking after the concrete has reached its initial set, to aid curing. No additional backfill shall be placed over arch encasement or blocking until the concrete has been in place for at least 3 days.
- G. Use of Geotextile Material:
  - 1. Where indicated on the Drawings, migration of soil into the embedment material shall be prevented with geotextile fabric.
  - 2. Geotextile material shall conform to Section 02230 – Geotextiles, paragraph GEOTEXTILES on Subsurface Drainage, unless otherwise indicated on the Drawings or in Section 01015 – Specific Project Requirements.
  - 3. Geotextile shall be placed on the trench surfaces so that it completely surrounds the embedment material. Joints shall be lapped 12 inches.

### 3.17 COMPACTION

- A. Granular Bedding – Vibratory compactors and shovel slicing under the haunches of the pipe.
- B. Granular Fill Material – The material in each layer shall be wetted or dried as required and thoroughly mixed to ensure uniform moisture content. Each layer shall be thoroughly compacted, utilizing a vibratory compactor, to achieve the minimum allowable density of 95% of the maximum dry density (at moisture content range from 3% below optimum to 2% above optimum as determined by ASTM D698). If the granular fill material fails to meet the minimum 95% density specified, the material shall be removed and compacted to achieve 95% or greater.
- C. CLSM – Not applicable.

- D. Suitable Material:
  - 1. Cohesive Materials – As required to obtain 95% maximum dry density in accordance with ASTM D698 with a moisture content range from 3% below optimum to 2% above optimum.
  - 2. Cohesion-less Materials – As required to obtain not less than 85% relative density as determined by ASTM D4253 and ASTM D4254.
- E. Job Excavated Material – Where job excavated material is used for trench backfill, the Contractor shall use compaction methods to ensure that settlement does not occur within the limits of trench excavation. The Contractor shall repair settlement as directed by the City at any time during the Work or at any time during the warranty period. Repairs shall be made at no additional cost to the City.

### 3.18 FINAL SURFACING

- A. Final surfacing shall be indicated on the Drawings.
- B. For unpaved areas, see Section 02200 – Earthwork, paragraph FINAL GRADING AND PLACEMENT OF TOPSOIL.

### 3.19 DITCH CHECK

- A. Continuity of embedment material shall be interrupted by low permeability groundwater barriers to impede passage of groundwater through the embedment.
- B. Materials:
  - 1. Unpaved Areas – Suitable material classified as GC, SC, CL or ML-CL as defined in Section 02200 – Earthwork, paragraph MATERIAL ENCOUNTERED. Barriers shall be compacted to 95% maximum dry density in accordance with ASTM D698 with a moisture content range from 3% below optimum to 2% above optimum.
  - 2. Paved Areas – CLSM.
- C. Barriers shall be constructed the full depth of the trench and shall include the foundation, bedding, haunching, initial backfill and final backfill zones of the trench.
- D. Barriers shall be the full width of the trench excavation and 3 to 5 feet in length measured along the pipe.
- E. Barriers shall be placed in the trench at intervals as shown on the Drawings or as directed by City/Design Professional. Unless otherwise specified by the City/Design Professional or specified in Section 01015 – Specific Project Requirements, the spacing of the groundwater barriers shall not exceed 250 feet.
- F. The installed location of all groundwater barriers shall be noted on the Field Mark-Up Drawing and Construction Record Drawing.
- G. Construction of the groundwater barriers shall be incidental to trenching and backfilling. No separate measurement or payment will be made.

### 3.20 SPECIAL REQUIREMENTS

- A. For trench excavation within paved areas that required full depth and width pavement replacement, refer to additional instruction in Section 01015 – Specific Project Requirements.
- B. Suitable materials shall be approved by the City/Design Professional prior to backfill.
- C. Granular Fill Material may be used for final backfill in unpaved areas to within 18 inches of the final graded surface at the option of the Contractor.

### 3.21 DRAINAGE MAINTENANCE

- A. To the greatest extent practical, open trench excavations shall be protected from surface water. The Contractor shall conduct the Work in a manner that diverts surface water away from the open excavation.
- B. Trenches across roadways, driveways, walks or other trafficways adjacent to drainage ditches or watercourses shall not be backfilled prior to completion of backfilling the trench on the upstream side of the trafficway to prevent impounding water after the pipe has been laid.
- C. Bridges and other temporary structures required to maintain traffic across such unfilled trenches shall be constructed and maintained by the Contractor.
- D. Backfilling shall be done so that water will not accumulate in unfilled or partially filled trenches.
- E. All material deposited in roadway ditches or other water courses crossed by the line of trench shall be removed immediately after backfilling is completed; and the original cross section, grade and contour of the ditches or watercourses shall be restored.
- F. Surface drainage shall not be obstructed longer than necessary.
- G. If the trench subgrade becomes unsuitable or unstable after the trench is excavated and as a result of the Contractor's inability to meet the requirements for DRAINAGE MAINTENANCE, then the Contractor shall over-excavate the unsuitable material and construct a foundation to the satisfaction of the City/Design Professional and at no additional cost to the City.

### 3.22 FIELD QUALITY CONTROL

- A. Compaction Tests:
  - 1. All tests shall conform to ASTM D6938. All tests required shall be made by an approved independent testing laboratory.
  - 2. Two initial gradation tests shall be made for each type of embedment, fill and backfill material.
  - 3. Storm and Sanitary Sewer Installations:
    - (a) Unless otherwise specified in Section 1015 – Specific Project Requirements, the minimum frequency of in-place compaction testing including density and moisture content will be as follows:
      - (i) Compaction testing is required for all trench zones where suitable material or granular fill material is placed.
      - (ii) Compaction testing is not required for granular bedding material or zones of random fill.
      - (iii) One compaction test shall be done every 100 feet of trench length under pavement and for every three vertical feet of backfill lifts placed. A minimum of two sets of tests are required for each trench backfilled regardless of length.
      - (iv) One compaction test will be done for every 300 feet of trench length in unpaved areas and for every three vertical feet of backfill lifts placed. A minimum of two sets of tests are required for each trench backfilled regardless of length.
      - (v) As required when the City/Design Professional suspects the quality of moisture control or effectiveness of compaction.
  - 4. Water Mains and Service Lines:
    - (a) Unless otherwise specified in Section 01015 – Specific Project Requirements, the Contractor shall conduct a minimum of ten (10) in-place

compaction tests at various locations throughout the project area as designated by the City/Design Professional.

5. Backfill that fails to meet required densities shall be removed and compacted as necessary to achieve specified results at no additional cost to the City.
- B. Controlled Low-Strength Material (CLSM) Tests:
1. Determine unconfined compressive strength using cylinders of CLSM sampled, handled, cured and tested in accordance with ASTM D4832. All tests required shall be made by an acceptable independent testing laboratory at the expense of the Contractor.
  2. The minimum frequency of compressive strength testing will be one set of cylinders obtained once per day or for every 100 cubic yards of flowable backfill placed.
- C. Field Quality Control shall be considered incidental to the Work associated with trenching, backfill and compaction. The Contractor shall include all costs in the Bid Price and no separate measurement or payment shall be made.

### 3.23 DISPOSAL OF EXCESS EXCAVATED MATERIALS

- A. Except as otherwise permitted in Section 01015 – Specific Project Requirements, all excess excavated materials shall be hauled off and disposed of off-Site by the Contractor.
- B. The disposal of waste and excess excavated materials, including hauling, handling, grading and surfacing shall be incidental to the work associated with trenching, backfill and compaction. No separate measurement or payment shall be made.

### 3.24 SEEDING AND SODDING

- A. All areas disturbed by the Contractor's operations shall be seeded or sodded according the requirements of Section 02930 – Seeding or Section 02931 – Sodding.

### 3.25 SETTLEMENT

- A. The Contractor is solely responsible for all settlement of backfills, fills and embankments which may occur within the correction period as stipulated in the General Conditions and Supplementary Conditions. The Contractor shall make or cause to be made, all repairs, replacements and restoration associated with settlement within 30 days after receipt of notice from the City.

Drawings 02250-1 and 02250-2 on the following 2 pages.

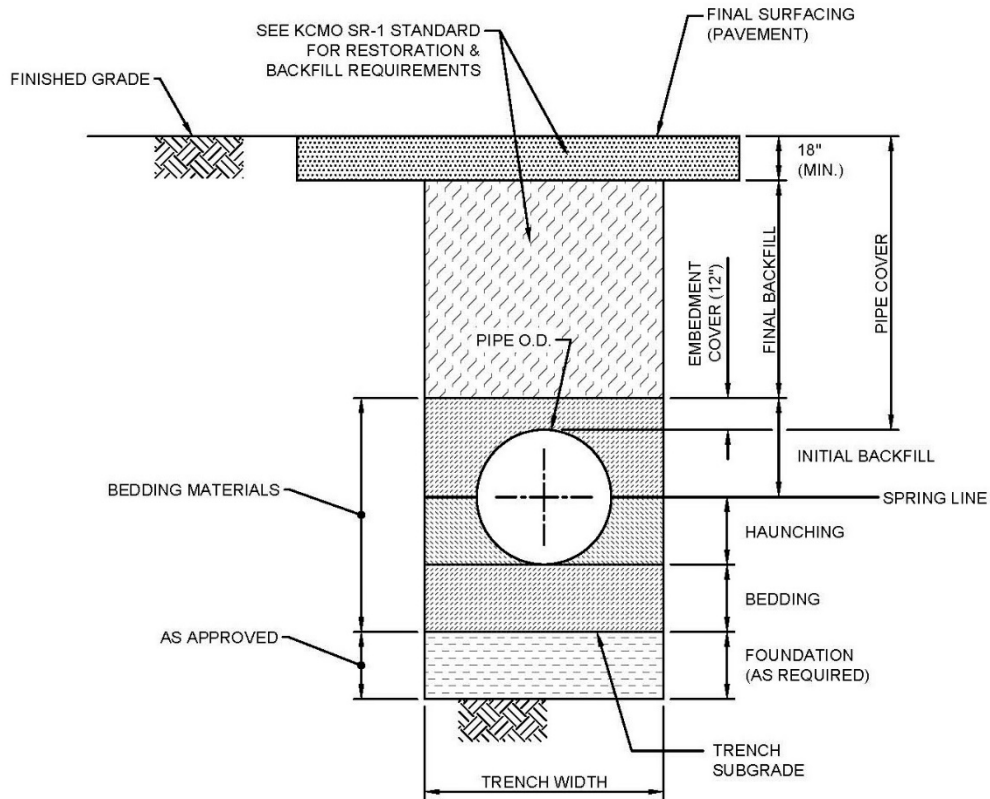

**TRENCH DETAIL, CLASS A BEDDING,  
PAVED AREAS**

WATER SERVICES  
CITY OF KANSAS CITY, MISSOURI

DRAWING NO. **02250-1**

DEVELOPED BY: \_\_\_\_\_  
TECHNICAL ADVISORY COMMITTEE

APPROVED BY: \_\_\_\_\_  
DATE: 09/16/2021

1 OF 1

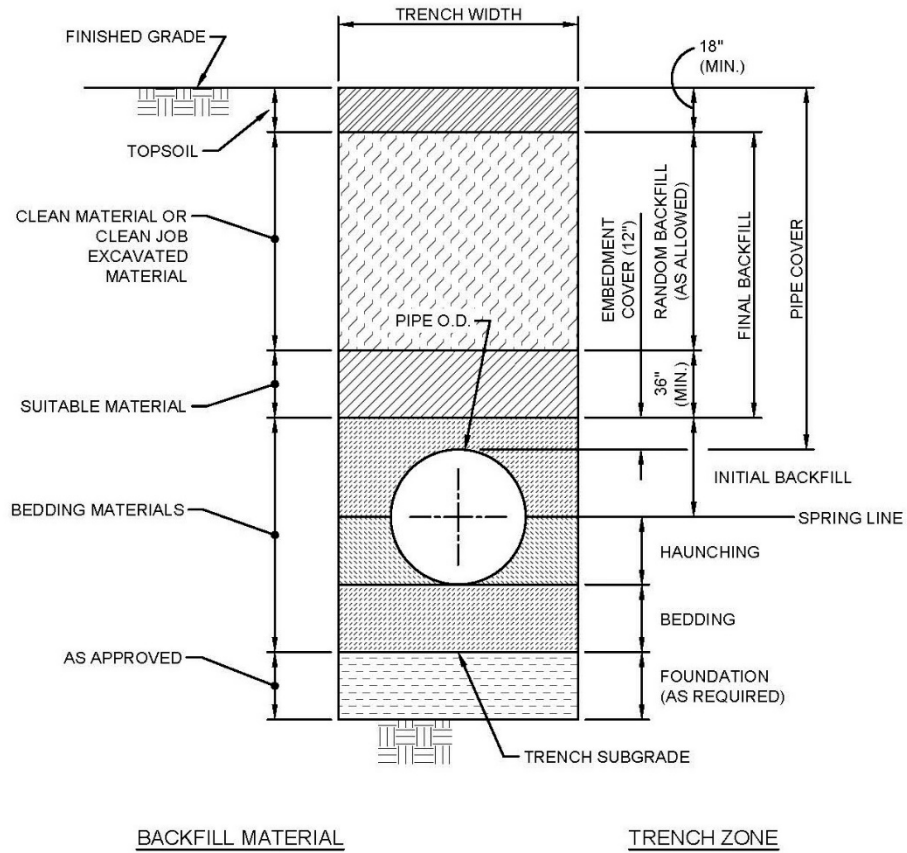

**TRENCH DETAIL, CLASS A BEDDING,  
UNPAVED AREAS**

WATER SERVICES  
CITY OF KANSAS CITY, MISSOURI

DRAWING NO. **02250-2**

DEVELOPED BY: \_\_\_\_\_  
TECHNICAL ADVISORY COMMITTEE

APPROVED BY: \_\_\_\_\_  
DATE: 09/13/2021

1 OF 1

**END OF SECTION**



## SECTION 02618

### DUCTILE IRON PIPE WATER MAIN

#### PART 1 GENERAL

##### 1.1 Section Description

- A. This section provides for pipe, fittings, and appurtenances associated with the installation of ductile iron pipe water main.

##### 1.2 Section Includes

- A. Pipe
- B. Fittings
- C. Appurtenances
- D. Shop Coating and Lining
- E. Bolts and Nuts
- F. Protective Coatings

##### 1.3 Related Sections

- A. Section 01016 – Water Mains Near Sewers
- B. Section 01300 – Submittals
- C. Section 01600 – Material and Equipment
- D. Section 02200 – Excavation and Trenching
- E. Section 02575 – Surface Restoration
- F. Section 02608 – Concrete Vaults
- G. Section 02641 – Valves
- H. Section 02645 – Hydrants, Blow-offs and Flushing Assemblies
- I. Section 02669 – Thrust Restraints
- J. Section 02675 – Water Main Testing, Disinfection and De-chlorination

##### 1.4 References

- A. ANSI/NSF61 - Drinking Water Treatment Chemicals.

- B. ASTM A53 - Standard Specification for Pipe, Steel, Black and Hot-Dipped, Zinc Coated, Welded and Seamless.
- C. ASTM A307 - Standard Specification for Carbon Steel Bolts and Studs, 60,000 psi Tensile.
- D. ASTM D4976 - Standard Specification for Polyethylene Tubing.
- E. AWWA C104/ANSI A21.4 - Cement-Mortar Lining for Cast-Iron Pipe and Fittings.
- F. AWWA C105/ANSI A21.5 - Polyethylene Encasement For Ductile Iron Piping.
- G. AWWA C110/ANSI A21.10 - Gray-Iron and Ductile Iron Fittings.
- H. AWWA C111/ANSI A21.11 - Rubber-Gasket Joints for Cast Iron and Ductile Iron Pressure Pipe and Fittings.
- I. AWWA C115/ANSI A21.15 - Flanged Ductile-Iron Pipe with Ductile Iron or Gray Iron Thread.
- J. AWWA C150/ANSI A21.50 - Standard for the Thickness Design of Ductile Iron Pipe.
- K. AWWA C151/ANSI A21.51 - Ductile Iron Pipe Centrifugally Cast for Water.
- L. AWWA C153/ANSI A21.53 - Ductile-Iron Compact Fittings, 3 in. through 24 in.
- M. AWWA C203 - Standards for Steel Pipe.
- N. AWWA C550 - Protective Epoxy Interior Coatings for Valves and Hydrants.
- O. AWWA C600 - Installation of Ductile Iron Water Mains and their Appurtenances.

## **1.5 Submittals**

- A. Follow the procedures for submittals provided in Section 01300 - Submittals
- B. Submit shop drawings and project data (laying schedule) for piping work showing pipe and fitting sizes, valve locations, joint details; and hydrant locations.

## **1.6 Quality Assurance**

- A. Follow provisions of AWWA C600.
- B. The manufacturer shall be a company specializing in manufacturing the Products specified in this section with minimum three years documented experience.
- C. Mark rejected or defective materials and remove them from the work site.

## 1.7 Delivery, Storage, and Handling

- A. Follow the provisions for the delivery, storage, protection and handling products to and at site provided in Section 01600 - Material and Equipment.
- B. Accept piping on site. Inspect for damage and inventory.

## PART 2 PRODUCTS

### 2.1 Water Main Pipe Materials

#### A. Pipe

- 1. Unless indicated otherwise, all 4" diameter through 12" diameter shall be thickness class 52. Pipe 16-inch diameter and larger shall be thickness Class 54 minimum. The pipe shall be designed in accordance with AWWA C150-ANSI A21.50 and manufactured per AWWA C151-ANSI A21.51 complete with all accessories.
- 2. All ductile iron pipe, and all fittings, valves, and other buried appurtenances, shall be encased in polyethylene.
- 3. Joints: The joints shall be of the push-on type unless otherwise specified conforming to ANSI/AWWA C111/A21.11, except gaskets shall be neoprene or synthetic rubber. Gaskets shall be certified as suitable for chlorinated potable water in accordance with ANSI/NSF61. Natural rubber will not be acceptable.
- 4. Restrained Joints: See Section 02669.

#### B. Fittings

- 1. All fittings shall be made of Ductile Iron and manufactured according to AWWA C110/ANSI A21.10 or AWWA C153/ANSI A21.53.
- 2. Fitting joints shall be Mechanical Joint (MJ), Flange Joint (FLG), or Push-On Joint, per AWWA C111/ANSI A21.11. All MJ glands shall be ductile iron. Fittings shall have distinctly cast upon them, the pressure rating and the letters "DI" or "Ductile". FLG Fittings shall be used only for aboveground installations.
- 3. Flanged Joints: Shall be provided with full-face gaskets and shall meet the requirements of AWWA C115/ANSI A21.15.

#### C. Appurtenances

- 1. Welded - On Outlets: May not be used in lieu of tees.
- 2. Tapping Sleeves:
  - a. Material: All material in the body, lugs, outlet, flange, bridge plate, bolts, nuts and washers shall be ASTM A-276 Type 304 or Type 316 or ASTM A-564 Type 630 stainless steel.

- b. Body: Shall be a minimum of 14 gauge stainless steel and shall fit cast iron pipe classes A, B, C, and D.
  - c. Outlet: Shall be a minimum of 14-gauge stainless steel. The branch outlet shall be supplied with a tap and plug to permit pressure testing the sleeve prior to tapping the main.
  - d. Flange: Shall conform to AWWA C207 Class D with drilling in accordance with ANSI B 16.1 class 125, and shall be indexed per MSS-SP 60 to accept tapping valve.
  - e. Welding: All welding on the coupling shall be done with stainless steel rods.
  - f. Gaskets: Sleeve gaskets shall be full circumferential a minimum of ¼” thick gridded with tapered lap joint ends and stainless steel bridge plates molded flush into the gasket.
  - g. The Outlet: The outlet flange face shall be supplied with a bonded, full-face gasket. All gaskets shall be grade 30 specially compounded rubber, synthetic rubber, or 100 percent neoprene that shall have the necessary qualities to allow outside storage, permanence, and resistance to set after installation.
  - h. Bolts and Nuts: All bolts, nuts and washers shall be loose; lifter bar style bolt attachments shall not be permitted. All bolts and/or nuts shall be impregnated or coated to prevent seizure. Minimum diameter shall be 5/8”.
  - i. Working Pressure: Sleeve shall be designed for a minimum working pressure of 175 psi.
  - j. General: Power Seal Model 3490-AS; JMC 432; Cascade CST-Ex stainless steel extra heavy duty; Ford Model FTSS; Romac STD Band SST-III; Smith Blair Type 665.
  - k. Power Seal Model 3490MJ or approved equal may also be used.
3. Tie Rods: ASTM A276, Type 304 or Type 316 Stainless Steel.
  4. Couplings: Dresser “Style 38” or Smith-Blair “441 or 411 Flexible Coupling”; without pipe stop. Bolted compression type couplings shall be manufactured of steel or ductile iron specifically for use with ductile iron pipe.

#### D. Shop Coating and Lining

1. All pipe and fittings shall be cement mortar lined in accordance with AWWA C104/ANSI A21.4. Pipe cement-mortar lining shall be without an asphaltic interior seal coating. All buried pipe and fittings shall be exterior coated with a black asphaltic coating minimum 1 mil in thickness per AWWA C151/ANSI A21.51. Any pipe or fittings above ground shall be prime coated with 6 mils DFT of Tnemec 140-1211 Epoxy Primer.
2. The exterior of ductile iron pipe shall be coated with a layer of arc-sprayed zinc per ISO 8179. The mass of the zinc applied shall be 200 g/m<sup>2</sup> of pipe surface area. A finishing layer topcoat shall be applied to the zinc. The mean dry film thickness of the finishing layer shall not be less than 3 mils with a local minimum not less than 2 mils. The coating system shall conform in

every respect to ISO 8179-1 "Ductile iron pipes - External zinc-based coating - Part 1: Metallic zinc with finishing layer. Second Edition 2004-06-01.

3. Ductile Iron Pipe used for sewers shall have an interior protective coating of Tnemec 431 coating.

E. Bolts and Nuts

1. Bolts: ASTM A307, chamfered or rounded ends projecting 1/4 to 1/2 inch from surface.
2. Nuts: ASTM A307, hexagonal, ANSI B18.2.2.

F. Marking:

1. Markings shall be legibly indented in the pipe or painted thereon with waterproof paint.

## 2.2 Protective Coatings

A. Polyethylene Encasement:

1. Polyethylene encasement materials shall be in accordance with ASTM D4976 and AWWA C105/ A21.5; LLD-12 mil or HDCL-4 mil. LLD-12 mil polywrap shall be blue.

<u>Item</u>	<u>LLD-12 mil</u>	<u>HDCL-4 mil</u>
Tensile Strength, psi	4,400	6,300
Elongation, percent	1,000	100
Dielectric Strength, v/mil	1,900	800
Tear Resistance, gf	4,400	250
Impact Resistance, g	1,100	800

2. The minimum tube size for each pipe diameter shall be in accordance with AWWA C105 as follows:

### Polyethylene Flat Tube Width (inches)

Nominal Pipe Diameter (inches)	Push-on Bell & Spigot Joints	Mechanical Joints
4	14	16
6	17	20
8	21	24
10	25	27
12	29	30
14	33	34
16	37	37
18	41	41
20	45	45
24	53	53

3. Adhesive tape shall be a general purpose adhesive tape 1-inch wide and approximately 8 mils thick, such as Scotch Tape No. 50, Polyken No. 900, Tapecoat CT or approved equal (Duct Tape will not be allowed).
  - B. Exterior Surfaces Underground (Excluding Pipe & Fittings): All metal surfaces, including each mechanical coupling, shall be thoroughly cleaned and then coated with Tnemec coal-tar epoxy "High-Build Tnemec-Tar". All material and the application thereof shall conform to AWWA C203.
  - C. Above ground pipe and fittings shall be field coated with Tnemec Coal Tar Epoxy "High-Build Tnemec-Tar."

## PART 3 EXECUTION

### 3.1 Handling

- A. Pipe, fittings, and accessories shall be handled in a manner that will ensure installation in a sound, undamaged condition. Equipment, tools, and methods used in unloading, reloading, hauling, and laying pipe and fittings shall be such that the pipe, pipe coating, and fittings are not damaged. Hooks shall not be used. Under no circumstances shall pipe or accessories be dropped or dumped. Pipe and fittings shall not be moved by inserting anything into pipe ends.
- B. Pipe and fittings on which the cement lining has been broken or loosened shall be replaced. Where the damaged areas are small and readily accessible, the lining may be permitted to be repaired in accordance with AWWA C104.

### 3.2 Inspection

- A. Pipe and fittings shall be carefully examined for cracks and other defects immediately before installation. Spigot ends shall be examined with particular care since they are vulnerable to damage from handling. All defective, damaged, or unsound pipe and fittings shall be rejected and marked as such and removed from the site of the work.

### 3.3 Preparation

#### A. Cutting Pipe:

1. Ductile iron pipe shall be cut with a saw or an abrasive wheel. Existing cast iron pipe shall be cut with a saw or abrasive wheel.
2. The cutting of pipe with a torch will not be permitted.
3. Cutting shall be done in a neat manner without damage to the pipe or the cement lining. Cuts shall be smooth, straight, and at right angles to the pipe axis. After cutting, the end of the pipe shall be dressed with a file to remove all roughness and sharp corners.

#### B. Cleaning:

1. The interior of all pipe and fittings shall be thoroughly cleaned of foreign matter before being installed and shall be kept clean until the work has been accepted.
2. Surfaces shall be wire brushed, if necessary, wiped clean, and kept clean until jointing is completed.

### 3.4 Installation

#### A. General

1. Alignment: Runs intended to be straight shall be laid straight. Deflections from a straight line or grade shall not exceed the quantities stipulated in Table 4 or Table 5 of AWWA C600. Shorter pipe sections or special bends shall be installed where the alignment or grade requires them.
2. Laying Pipe: Pipe shall be protected from lateral displacement by pipe embedment material installed as specified in Section 02200. Under no circumstances shall the pipe be laid in water; and no pipe shall be laid in unsuitable trench conditions.
  1. Pipe shall be laid with the bell ends facing the direction of laying except when reverse laying is specifically authorized by the WSD.
  2. Whenever pipe laying is stopped, the open end of the line shall be sealed with a watertight plug that will prevent water and objects from entering the pipe.
3. No pipe length less than 18" shall be used.

#### B. Mechanical Joints:

1. The gasket and gland shall, after proper joint cleaning, be in position on the spigot before shoving the pipe to its final position. Center the entering spigot so that the gland or follower ring is parallel to the face of the connecting bell. Joint shall be shoved "home" and the gland properly positioned with respect to the

connecting bell with the connecting pipes in as nearly perfect alignment as practicable. The bolts shall be slightly and uniformly tightened. Deflection may be made after the bolts are tightened.

2. Coat the gasket with a lubricant (suitable for potable water) supplied by the pipe manufacturer and all surfaces of the bell, spigot, and gland that will come in contact with the gasket at any time during assembly.
3. Gasket shall be carefully pushed into position and evenly seated in the bell. The gland shall be shoved into place against the gasket, the bolts inserted, and the nuts tightened with the fingers until snug. Final tightening of the bolts shall be done with a ratchet torque wrench.
4. Partially tighten the bottom bolt, then the top bolts, alternately either side, and finally the remaining bolts, alternately tightening bolts 180 degrees apart. This cycle is then to be repeated until all bolts are tightened to the torque specified by the manufacturer:

5/8" bolts --- 40 to 60 foot pounds

3/4" bolts --- 60 to 90 foot pounds

5. If sealing is not maintained at the torque specified, the joint shall be disassembled, thoroughly cleaned, and reassembled. Overstressing of bolts to compensate for poor installation practice will not be permitted.

C. Push-On Joints:

1. Wipe the gasket seat clean with a cloth and position in place. Coat the gasket with a lubricant supplied by the pipe manufacturer. Apply to all of the inner surface of the gasket that will come into contact with the entering pipe.
2. Clean the plain end of the pipe and apply a thin film of lubricant (suitable for potable water) to the outside of the plain end of the pipe and its beveled edge. Align the plain end of the pipe with the bell of the pipe to which it is to be joined. The joint deflection angle should not exceed the recommended maximum of the manufacturer.
3. Bring the plain end of the pipe in contact with the gasket and exert sufficient force on the entering pipe so that its plain end compresses the gasket and makes contact with the base of the socket of the bell. This force can be applied by means of a jack type tool, backhoe, or other methods approved by the WSD.

D. Flanged Joints:

1. When bolting, care shall be taken to provide uniform gasket compression and prevent unnecessary stress on the flanges. Flange shall be free to move in any direction while the flange bolts are being tightened. Bolts shall be tightened gradually and at a uniform rate to provide uniform gasket compression.
2. Use full-face gaskets only.



E. Restrained Joints:

1. Restrained joints shall be installed in accordance with the pipe manufacturer's recommendations.
2. All joints within utility casings shall be restrained joints.

F. Encasement:

1. Polyethylene encasement shall be installed on all ductile iron pipe and fittings. The polyethylene shall prevent contact between the pipe, fittings, and the surrounding embedment.
2. The polyethylene encasement shall be installed as specified in "Method A" below and as shown on the Construction Detail Drawing No. 02618-1.
  - a. Method A: Polyethylene tubing shall be approximately two (2) feet longer than the length of the pipe section to provide a one (1) foot overlap on each adjacent pipe section. Tube ends need not be taped in place unless directed by the WSD. Repair rips, punctures, or other damages to the polyethylene with adhesive tape or with a short length of polyethylene tube cut open, wrapped around the pipe, and secured with adhesive tape as directed by the WSD (duct tape is not allowed).
3. Pipe-Shaped Appurtenances: Bends, reducers, offsets, and other pipe-shaped appurtenances shall be covered with polyethylene in the same manner as the pipe.
4. Odd-Shaped Appurtenances: Valves, tees, crosses, and other odd-shaped pieces that cannot practically be wrapped in a tube shall be wrapped with a flat sheet or split length of polyethylene tube. The sheet shall be passed under the appurtenance and brought up around the body. Seams shall be made by bringing the edges together, folding over twice, and taping down. Tape polyethylene securely in place at overlaps, valve tops and all other penetrations.
5. Lifting devices shall not be placed over polyethylene.
6. Polyethylene shall be protected from exposure to weather or damage at all times.
7. Openings in Encasement: Openings for branches, service taps, blow-offs, air valves, and similar appurtenances shall be made by making an x-shaped cut in the polyethylene and temporarily folding the film back. After the appurtenance is installed, tape the slack securely to the appurtenance and repair the cut as well as any other damaged areas in the polyethylene with tape. The new appurtenance shall be wrapped.
8. Junctions between Wrapped and Unwrapped Pipe: Where polyethylene wrapped pipe joins an existing pipe which is not wrapped, extend the

polyethylene tube to cover the unwrapped pipe a distance of at least three feet. Secure the end with circumferential turns of tape.

9. Taps: Wrap 3 layers of adhesive tape over the polyethylene, covering the area where the tapping machine will be mounted. Mount the machine over the tape. Make the tap and install the corporation stop through the tape and polyethylene. After making the service connection, inspect the polyethylene, and repair damaged areas with tape.

### **3.5 Water Main and Sewer Separation**

- A. Refer to Section 01016

### **3.6 Appurtenances**

- A. Concrete Vaults: Refer to Section 02608
- B. Valves: Refer to Section 02641
- C. Hydrants, Blow-off, and Flushing Assemblies: Refer to Section 02645
- D. Thrust Restraints: Refer to Section 02669

END OF SECTION

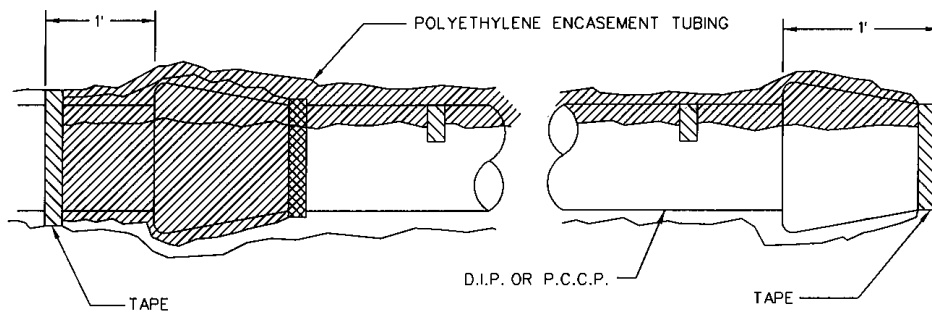

METHOD A

NOTES

1. TAPE IN ACCORDANCE WITH AWWA C-105

POLYETHYLENE ENCASEMENT FOR BURIED PIPE

WATER SERVICES DEPARTMENT CITY OF KANSAS CITY, MISSOURI

REVISED: APRIL 2014

CONSTRUCTION DETAIL DRAWING NO. 02618-1

## **SECTION 02641**

### **VALVES**

#### **PART 1 GENERAL**

##### **1.1 Section Description**

- A. This section provides for the installation of required valves for water main construction.

##### **1.2 Section Includes**

- A. Gate Valves
- B. Butterfly Valves
- C. Air Release Valves
- D. Tapping Valves
- E. Valve Boxes, Bases, Lids and Covers, Torque Limiting Devices
- F. Valve Seals and Coatings
- G. Check Valves

##### **1.3 Related Sections**

- A. Section 01300 – Submittals
- B. Section 01600 – Material and Equipment
- C. Section 02608 – Concrete Vaults
- D. Section 02618 – Ductile Iron Pipe Water Main
- E. Section 02669 – Thrust Restraints

##### **1.4 References**

- A. ANSI B16.1 - Pipe Flanges and Flanged Fittings, Cast-Iron
- B. ANSI/AWWA C110/A21.10 - Ductile-Iron and Gray-Iron Fittings.
- C. ANSI/AWWA C111/A21.11 - Rubber-Gasket Joints for Ductile-Iron Pressure Pipe and Fittings.
- D. AWWA C504 - Rubber-Seated Butterfly Valves.

- E. AWWA C509-94 - Standard Specification for Resilient Seated Gate Valves for Water Supply Service.
- F. AWWA C512-99 - Air Release, Air/Vacuum, and Combination Air Valves for Water Works Service.
- G. ASTM A48 - Standard Specifications for Gray-Iron Castings.
- H. ASTM A126 - Standard Specifications for Gray-Iron Castings for Valves, Flanges, and Pipe Fittings.
- I. ASTM A276 - Standard Specification for Stainless Steel Bars and Shapes.
- J. ASTM A536 - Standard Specification for Ductile Iron Castings.
- K. ASTM A564 - Standard Specification for Hot-Rolled and Cold-Finished Stainless Steel Bars and Shapes.
- L. ASTM D471 - Standard Test Method for Rubber Property-Effect of Liquids.
- M. ASTM D1149 - Standard Test Method for Rubber Deterioration-Surface Ozone Cracking in a Chamber.
- N. C508: Swing-Check Valves for Waterworks Service, 2 in. through 24 in.

## **1.5 Submittals**

- A. Follow the procedures for submittals provided in Section 01300 - Submittals
- B. Shop Drawings: Detailed drawings, data and descriptive literature on all valves and appurtenances, including:
  - 1. Manufacturer
  - 2. Dimensions
  - 3. Size
  - 4. Materials of construction
  - 5. Weight
  - 6. Protective coating
  - 7. Actuator weight and turns to operate where applicable
  - 8. Calculations for actuator torque where applicable
  - 9. Proof of design tests in accordance with Sec. 5.2.4. AWWA C504
  - 10. Cross section drawings detailing all components

- C. The Contractor shall submit descriptive literature describing the proposed valves and accessories. Contractor shall also furnish a copy of the manufacturer's warranty that applies to the valves and actuators.

## **1.6 Quality Assurance**

- A. Valves shall be manufactured by a company specializing in the regular production of the Products specified herein and proven reliable in similar service for at least five (5) years.
- B. Insofar as possible, all valves of the same specific type shall be the product of one (1) manufacturer.

## **1.7 Delivery, Storage and Handling**

- A. Follow the provisions for the delivery, storage, protection and handling Products to and at site provided in Section 01600 - Material and Equipment.

## **PART 2 PRODUCTS**

### **2.1 General**

- A. Marking and identification of valves shall conform to AWWA C504 or AWWA C509.

### **2.2 Gate Valves**

- A. Gate Valves: Except as modified or provided herein, all gate valves shall be 200 psi, ductile iron body, resilient-seated, tight closure gate valves with non-rising stems conforming to the requirements of AWWA C509. Thin wall valves are prohibited.
- B. Valve Ends:
  - 1. Mechanical Joint or Push On Joint: Conforming to ANSI/AWWA C111/A21.11 except where flange ends are required. All glands shall be ductile iron.
  - 2. Flanged: Conforming to the dimensions and drilling of ANSI B16.1 for cast iron flanges and flange fittings, Class 125. The laying lengths of the flange valves shall conform to the dimensions of ANSI B16.1.
- C. Valve Gate: Wedge type gate with a minimum 3/8 inch thick resilient rubber, urethane rubber, Buna "N" or SBR rubber bonded to or mechanically attached to one side or both sides of the gate. No sliding or shear is permitted on the resilient seat, when compressed to a drop-tight shut-off.
- D. Fasteners: All exterior bolts and nuts shall be ASTM A276 Type 304 or Type 316 stainless steel.

- E. Operating Nut: The valve shall be equipped with a two-inch square AWWA **stainless steel** nut having a flanged base upon which shall be cast the word OPEN and an arrow indicating the direction to open. The nut shall be securely pinned to the actuator shaft using a stainless steel fastener
- F. Valve Stems: The gate valve stems shall be produced from a material that is corrosion resistant to potable water and has a minimum yield strength of 40 KSI.
- G. Seals: Gate Valves shall be provided with stem seals of the "O" ring type. Two "O" rings shall be used with at least one "O" ring inserted above the thrust collar. The packing plate shall be attached to the valve bonnet by not less than two (2) bolts if bolts are required and one "O" ring below the thrust collar.
- H. Coatings: All exterior surfaces of each valve shall be cleaned and painted in the shop with two (2) coats of asphalt varnish conforming to Federal Specifications TT-V-51-E. The interior surface shall have a protective coating of fusion-bonded, non-toxic epoxy that is safe for potable water. Non-toxic epoxy may also be used for exterior coating
- I. Tapping Valves: The valves shall be 200 psi, ductile iron body, resilient-seated, tight closure gate valves with non-rising stems in conformance with ANSI/AWWA C509, except that the outlet end shall be a standard mechanical joint end conforming to ANSI/AWWA C111/A21.11 and the inlet end shall have an inlet flange conforming to ANSI B16.1 for cast iron flanges, Class 125. Gland shall be ductile iron. Approved mechanical joint valves shall be used with Power Seal Model 3490MJ tapping sleeves.

### 2.3 Butterfly Valves

- A. General: These specifications provide for the purchase and installation of ductile iron, vault installation or direct bury, rubber-seated, tight closure in both directions, 16 fps butterfly valves and actuators in sizes from 16-inch through 90-inch diameter. All valves shall be Short-Body Flanged-end valves for use in vaults or Mechanical-Joint-end valves for direct bury. The valves and actuators shall be of the latest model with all standard accessories ordinarily furnished to the industry except as otherwise specified herein. All valves of one size shall be built by one manufacturer with actuators built by one manufacturer. The latest revision of AWWA C504, Standard for Rubber Seated Butterfly Valves, shall govern unless noted otherwise herein. The intent of all provisions of AWWA C504 shall apply equally to valves larger than 48" diameter and to 250 psi valves unless noted otherwise herein. Each valve shall have a unique serial number, which shall be part of the information on the tag specified in paragraph 10.
- B. Owner's Data: The quantity, pressure rating, valve material type, and sizes shall be as indicated on the drawings. Each valve shall be fastened to and delivered on an individual pallet on 4" x 4", or heavier, wood skids, high enough to protect the valve and actuator. All other requirements of AWWA C504 Section 6.2 "Shipping" shall apply. Delivery shall be to the jobsite.
- C. Descriptive Literature: The Bidder shall include literature describing the valves and actuators to be furnished.

- D. Warranty: The Supplier shall furnish three copies of the warranty that applies to the valves and actuators they propose to furnish. The warranty period shall be for a minimum of three years after substantial completion of the contract under which the valve is installed or twenty years from the date of shipment, whichever comes first.
- E. Shop Drawings: The approved Supplier, ONLY, before manufacturing the valves and actuators, shall submit eight (3) sets of certified shop drawings, parts lists, exploded assembly drawings, and material specifications, for approval, to the WSD. In addition to the above, the supplier shall furnish certified copies of proof-of-design tests performed in accordance with Section 5.2.4 of AWWA C504.
- F. Design: All valve parts shall be designed for a minimum safety factor of 3, based on yield strength, or 5, based on tensile strength.
- G. Flow Coefficient "K": The flow coefficient in terms of velocity head (K), in the full open position, shall not be greater than the following:

	<u>75 psi</u>	<u>150 psi</u>	<u>250 psi</u>
16 inch thru 24 inch	K=0.40	K=0.45	K=0.55
30 inch thru 48 inch	K=0.40	K=0.40	K=0.50
54 inch thru 72 inch	K=0.40	K=0.40	-----
78 inch thru 90 inch	K=0.40	-----	-----

Pressure measurements shall be made at two pipe diameters upstream of the valve and eight pipe diameters downstream of the valve in accordance with recommended procedures of ASME Report on Fluid Meters, Latest Edition.

- H. Minimum Port Diameter: The minimum port diameter through the valve shall not be less than as listed below:

<u>Nominal Size</u>	<u>Allowable Difference in Diameter</u>
16-inch - 42 inch	1 inch
48-inch - 54-inch	1 1/4-inch
60-inch - 72-inch	1 1/2-inch
78-inch - 90-inch	3 inch

- I. Fasteners: All bolts and nuts inside and outside the valve, except Mechanical Joint bolts and nuts, shall be ASTM A276 Type 304 or Type 316 stainless steel or ASTM A564 Grade 630 stainless steel.
- J. Valve Body: The valve body shall be ductile iron poured to full gray iron thickness.

The position of the valve seat in the valve body shall be marked on the outside of the valve body, within 12 inches of the actuator nut of upper valve trunion, tagged or cast, in 1/4" high print, "SEAT THIS SIDE." Tags shall be ASTM A276 Type 304 or Type 316 stainless steel.



- K. End Plate: No bolt or end thrust adjusting screw shall extend through the End Plate.
- L. End Connections: The dimensions and drillings of end flanges shall conform to ANSI B16.1 for 75 psi valves, ANSI B16.1 Table 5 for 150 psi valve and 250 psi valves, both with 150 psi drillings. If specified in the invitation to bid, 250 psi dimensions and drillings of end flanges shall conform to ANSI B16.1 Table 8, to include but not be limited to, flange outside diameter, flange thickness, bolt circle diameter, bolt diameter, and bolt quantity. The Mechanical Joint valves are to include the following accessories: gaskets, ductile iron gland rings, mechanical joint bolts, and nuts.
- M. Shafts: All valve shafts shall be in accordance with AWWA C504 Table 3 unless otherwise addended herein. All valve shafts, dowels, and taper pins shall be ASTM A276 Type 304 or Type 316 stainless steel or ASTM A564 Grade 630 condition H1100 stainless steel. The valve shaft shall have a means of clearly indicating the position of the disc on the actuator end of the shaft. This mark shall be machine grooved and shall be visible when the cover and lubrication are removed and shall be offset to the same side as the disc. The valve shaft shall be completely enclosed between the valve body and the actuator body.
- N. Valve Disc: The valve disc shall be ductile iron and shall seat perpendicular to the centerline axis of the valve body.
- O. Valve Seats: The resilient seat shall be EPDM synthetic rubber applied either to the valve disc or valve body. The resilient seat shall be mechanically secured to either the valve disc or valve body with ASTM A276 Type 304 or Type 316 stainless steel fasteners or non-bonding epoxy. Resilient seats shall be field adjustable and replaceable without special tools or instruction.

Mating surfaces for the valve seats shall be ASTM A276 Type 304 or Type 316 stainless steel.

All seats shall be designed to provide tight shut-off with flow in both directions.

- P. Shaft Seals: Seal shall be provided by the use of standard V-type packing or standard "O" ring seals; pull-down packing is not acceptable. The valve shall be designed so that the actuator may be removed and replaced while the valve is in service without losing water.
- Q. Actuator: The actuator shall be Limitorque Model HBC series or Auma Model GS series (additional spur gear reduction gear boxes may be necessary to achieve minimum "number of turns" requirement) or those that have received written approval after May 1, 2002 from the Water Services Department. The actuator shall be a link lever traveling nut type, worm gear type, or yoke and nut type and shall be capable of withstanding submersion in water to a pressure of 10 psi. All exposed bolts, nuts, and shafts shall be of ASTM A276 Type 304 or Type 316 stainless steel or ASTM A564 Grade 630 condition 1100 stainless steel. All actuators must have outside mechanical adjustments capable of adjusting valve travel without removing the valve from the pipeline or removing the actuator cover.

Buried service valves shall open right (clockwise). The actuator shall be equipped with a two-inch square AWWA ductile iron nut having a flanged base upon which

shall be cast the word OPEN and an arrow indicating the direction to open. The nut shall be securely pinned to the actuator shaft using a stainless steel fastener.

Vault service valves shall open left (counter-clockwise). The actuator shall be supplied with a handwheel. The handwheel shall be no smaller in diameter than 30 inches and no larger in diameter than 36 inches. Manual actuators shall be suitable for future adaptation to motor operation. Vault service actuators shall have an indicator on the exterior of the actuator indicating the valve disc position. This indicator shall be stainless steel.

All gearing and actuator stops shall be enclosed in a suitable housing with a removable cover to permit inspection, repair, and adjustment of the mechanism. Adjustable stop limiting devices shall be provided inside the actuator housing to stop the input shaft at full open and full closed positions. The use of stop nuts or shaft collars which rely on clamping forces or set screws to prevent rotation of the nut or collar on the screw shaft will not be acceptable.

The actuator shall rotate the disc from full open to full closed and vice-versa using not less than, nor more than, the number of turns indicated below:

Valve Size (Inches)	Minimum Turns	Maximum Turns
16	30	60
20	40	80
24	40	80
30	40	200
36	80	200
42	80	220
48	90	300
54	90	700
60	200	700
72	200	700
90	200	700

The number of turns shall be included in the information on the tag specified in paragraph 10.

- R. Painting Interior of Valves: The interior of valves sizes 16-inch through 48-inch shall be coated with a white, NSF 61 certified, fusion-bonded or powder coated epoxy. The interior of valve sizes 54-inch through 90-inch shall be coated with a white epoxy paint, Tnemec N141 NSF 61 or approved equal. Surface preparation and application shall be in accordance with SSPC PA-1. The dry film thickness of the coating shall be a minimum of 10 mils. A painting Affidavit of Compliance shall be submitted in accordance with paragraph 21 and AWWA C550 NSF 61 and shall be free of holidays.

- S. Painting Exterior of Valves: The exterior of valve sizes 16-inch through 48-inch shall be coated with an NSF 61 certified, fusion-bonded or powder coated epoxy. The exterior of valve sizes 54-inch through 90-inch shall be coated with an epoxy paint, Themec N141 NSF 61 or approved equal. Surface preparation and application shall be in accordance with SSPC PA-1. The dry film thickness of the coating shall be a minimum of 10 mils. A painting Affidavit of Compliance shall be submitted in accordance with paragraph 21 and AWWA C550 NSF 61 and shall be free of holidays.
- T. Factory Inspection: The Water Services Department's inspector will witness leakage and hydrostatic tests at the Manufacturer's facility and will inspect all valves for conformance to the specifications. The Manufacturer shall include in the bid all expenses for transportation, lodging, and meals required by the Department's inspector to complete the inspection. Absolutely no expenses are to be paid by the inspector at any time.

After the valves are delivered, the Water Services Department may again test the valves and actuators for compliance with the specifications. The valves that do not meet specification will be shipped back to the manufacturer for modifications, at the Manufacturer's expense. The manufacturer shall also be responsible for all testing expenses incurred by the Department if the valve fails to perform as specified herein.

- U. Tests: All test data per AWWA C504 shall be submitted in triplicate to the WSD.
- V. Affidavit of Compliance: The manufacturer shall send an affidavit of compliance, in triplicate, to the WSD.
- W. Torque Limiting Devices: Contractor shall provide a Torque Limiting Device for each direct-bury butterfly valve as specified herein.
1. The torque limiting device shall make over-torque, in either direction, impossible. The unit shall be preset and designed to release when the torque level exceeds 210 foot pounds on the operating nut, in either direction, OPENING or CLOSING the valve. The torque unit shall reset automatically when the torque level drops below 200 foot pounds on the operating nut in either direction.
  2. The torque level of the unit shall be adjustable so it may be field set to release at a desired torque limit.
  3. The device shall be model D86 Overtorque Protector, manufactured by Aunspach Controls Co, Inc. or approved equal.
  4. The unit shall be less than 5-1/4 inches in diameter and made to mount on the valve inside of the 6-inch diameter stem riser tube of the valve box or in the valve box.
  5. The unit shall be provided with a two-inch AWWA operating nut, securely attached to the device. The nut shall have an arrow on the base indicating the valve opens to the "RIGHT" (clockwise) and the word "OPEN". The unit shall be provided with a two-inch square tapered AWWA socket securely attached to the device. The socket shall fit a 2-inch AWWA nut.

6. The unit shall be designed to withstand submersion in water to a pressure of 10 psi; to endure long periods (years) of active or inactive use buried underground and submerged in water. The unit shall be sealed to prevent water and direct from entering the mechanism. The unit shall be packed with a suitable grease.
7. All housing parts, including nut and socket, shall be coated inside and outside with catalyzed (2-part) epoxy. A top coat of catalyzed (2-part) polyurethane enamel shall be applied over the epoxy for additional hardness and extra corrosion protection.
8. Contractor shall mount the torque limiting device's integral socket on each butterfly valve's 2-inch AWWA operating nut inside of the stem riser tube before backfilling around the valve. No fasteners or screws shall be used.

## **2.4 Air Release Valves**

### **A. Air Release Valves and Vaults:**

1. Air release assemblies shall be manufactured in accordance with AWWA C512.
2. Air release valve vaults and castings: Refer to Section 02608.
3. All piping shall be brass pipe except the air outlet from the air release valve that shall be brass or copper tubing. Brass piping shall be ASTM B43, Extra Strong with ASME 816.1 Class 250 fittings.

### **B. Air Release Valves for mains 12-inches in diameter or smaller (3/4-inch Diameter):**

1. Isolation valves shall be 3/4-inch bronze ball valves, 150 psi working pressure.
2. The 3/4-inch air release assembly shall be as manufactured by ARI Flow Control Accessories, Model S-050 or an approved equal.
3. Air release valves shall be installed in accordance with Drawing No. 02641-1.
4. Provide vault cover with minimum one 1-inch dia. hole for air flow.

### **C. Air Releases Valves for mains larger than 12-inches in diameter as specified on the Contract Drawings:**

1. For 2-inch air release valves:
  - a. Each assembly shall have a two-inch inlet connection.
  - b. Isolation valves shall be 2 inch bronze ball valves with screwed, non-rising stems, 175 psi working pressure..
  - c. The 2-inch air release valve shall be an ARI Flow Control Accessories Combination Air Release Valve, Model D-040 or approved equal.

- d. The 2-inch air release valves shall be installed in accordance with Drawing No. 02641-2.
  - e. Provide vault cover with a minimum four 1-inch dia. holes for air flow.
2. For 3-inch air release valves:
- a. The 3-inch air release valve shall be an ARI Flow Control Accessories Combination Air Release Valve, Model D-060-C HF or approved equal.
  - b. The 3-inch air release valves shall be installed in accordance with Drawing No. 02641-2B
  - c. Provide vault cover with a minimum nine 1-inch dia. holes for air flow.

## **2.5 Valve Boxes, Bases, Lids and Covers**

- A. One-piece Valve Boxes and Bases:
- 1. One-piece valve boxes and bases shall be injection molded plastic conforming to ANSI/ASTM 2853, Class 1212 as manufactured by Ametek or approved equal.
- B. Two-piece Valve Box and Base:
- 1. Valve Boxes: Boxes shall be 6" Class 52 DIP; or 6" Class 160 PVC pipe. Bases are required on all valves.
  - 2. Valves Bases: Valve bases shall be Clay & Bailey No. 2260-4 or an approved equal.
- C. Lids and Covers: Valve lids and covers shall be Clay & Bailey No. 2193, 2193NS or an approved equal. Valve lids shall have "Water" cast in the lid.

## **2.6 Check Valves**

- A. All check valves shall be Ken-Flex Resilient Hinge check valves as manufactured by Kennedy Valve Company or approved equal.
- B. Check valves shall be ductile iron body with reinforced Buna-N rubber flapper.
- C. Check Valves shall be rated for 250 psi working pressure, 500 psi hydrostatic test for structural soundness.
- D. Check Valves shall have ANSI 16.1 – Class 125 flanged end connections.
- E. The check valve body shall have full flow equal to nominal pipe diameter at all points in the valve. The valve body shall be of ductile iron construction to ASTM-A-536 –

65-45-12. Castings will be clean and sound without defects that will impair their service. No plugging or welding of such defects will be allowed. The seating surface will be at a 45 degree angle to minimize water hammer.

- F. Rubber Clapper & Hinge shall be constructed of ductile iron to ASTM-A 536-65-45-12. Both Clapper and hinge shall have permanently bonded Buna-N rubber with a metal reinforcement connecting the hinge to the clapper.
- G. The top cover plate will be of ductile iron to ASTM-A536-65-45-12 & must be of full size to allow removal of the disc without removing the valve from line. All exterior nuts and bolts shall be 304 or 316 stainless steel.
- H. All iron parts inside and out will be fusion bonded epoxy coated. All coatings must be NFS-61 approved for use in drinking water systems.
- I. Vault service check valves shall have an external mechanical position indicator.

### **PART 3 EXECUTION**

#### **3.1 Inspection**

- A. Each valve shall be inspected before installation to insure that all foreign substances have been removed from within the valve body, and shall be opened and closed to see that all parts are in required working condition.

#### **3.2 Setting Valves**

- A. All valves and fittings shall be set and jointed in the manner specified herein. The valves shall be set vertical in the horizontal pipeline. All valves shall be anchored directly to adjacent tees or crosses.
- B. One-piece valve box and base or a two-piece valve box and valve base shall be installed on all valves. An approved valve box alignment device shall also be installed in all valve boxes.
- C. Valve covers, bases, and lids shall be supported and maintained, centered and plumb over the actuator nut. Cover shall be flush with the roadway or ground surface or at such other as directed by the WSD.

#### **3.3 Appurtenances**

- A. Hydrants; Blow-off, and Flushing Assemblies: Refer to Section 02645
- B. Concrete Vaults and Covers: Refer to Section 02608
- C. Thrust Restraints: Refer to Section 02669
- D. General
  - 1. Certification: The manufacturer shall provide an affidavit in triplicate certifying that the valves and actuators comply with the provisions of these Specifications.

E. Leak Tests: (for Butterfly Valves)

1. Each valve shall be shop tested in both directions for leaks in the closed position. The test shall be conducted with the body in a horizontal plane.
2. Air pressure shall be applied to the lower face of the disc for 5 minutes.
3. Both 150-psi and 250-psi rated valves shall be leak tested to 250-psi pressure.
4. The upper surface of the valve disc shall be visible and covered with a pool of water at "O" psi pressure. There shall be no leakage past the valve disc. Bubbles will appear in the water on the disc if it is leaking.
5. The valve body shall be tested with an internal hydrostatic pressure equivalent to two times the specified shutoff pressure. There shall be no leakage, during the test, through the metal, the end joints, or the shaft seals; nor shall any part be permanently deformed.
6. The hydrostatic test period for 4-inch valve bodies through 20-inch bodies shall be at least 3 minutes. Valve bodies 24-inch and larger shall be tested for at least 10 minutes.

F. Performance Tests:

1. Each valve shall be shop operated three times from full closed to full open position, and reverse, under no flow condition to demonstrate that the complete assembly is workable.
2. Each valve should also be tested in the same manner following installation.

END OF SECTION

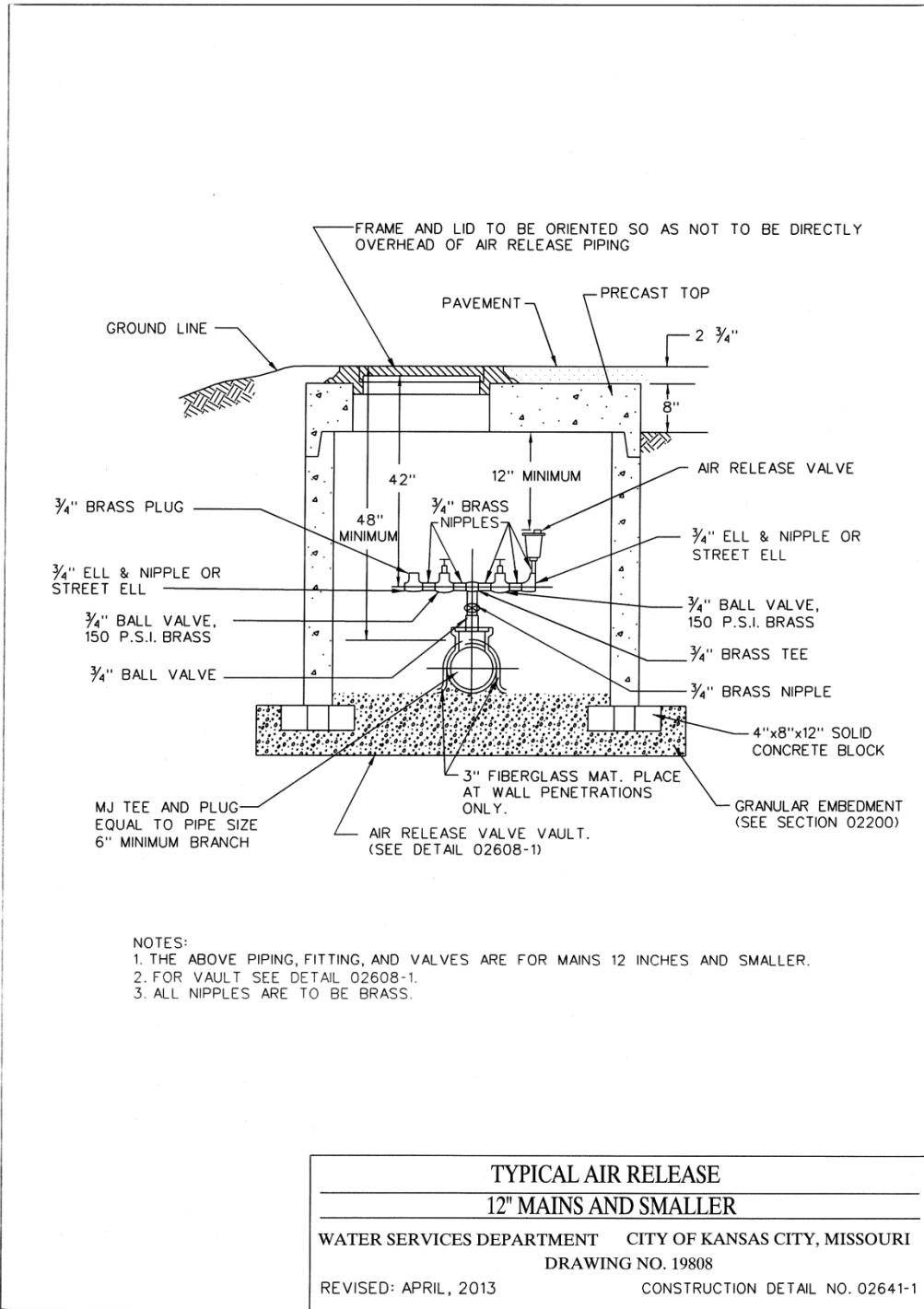

WaterWMSStd-airrelease.dgn 5/7/2013 4:25:07 PM



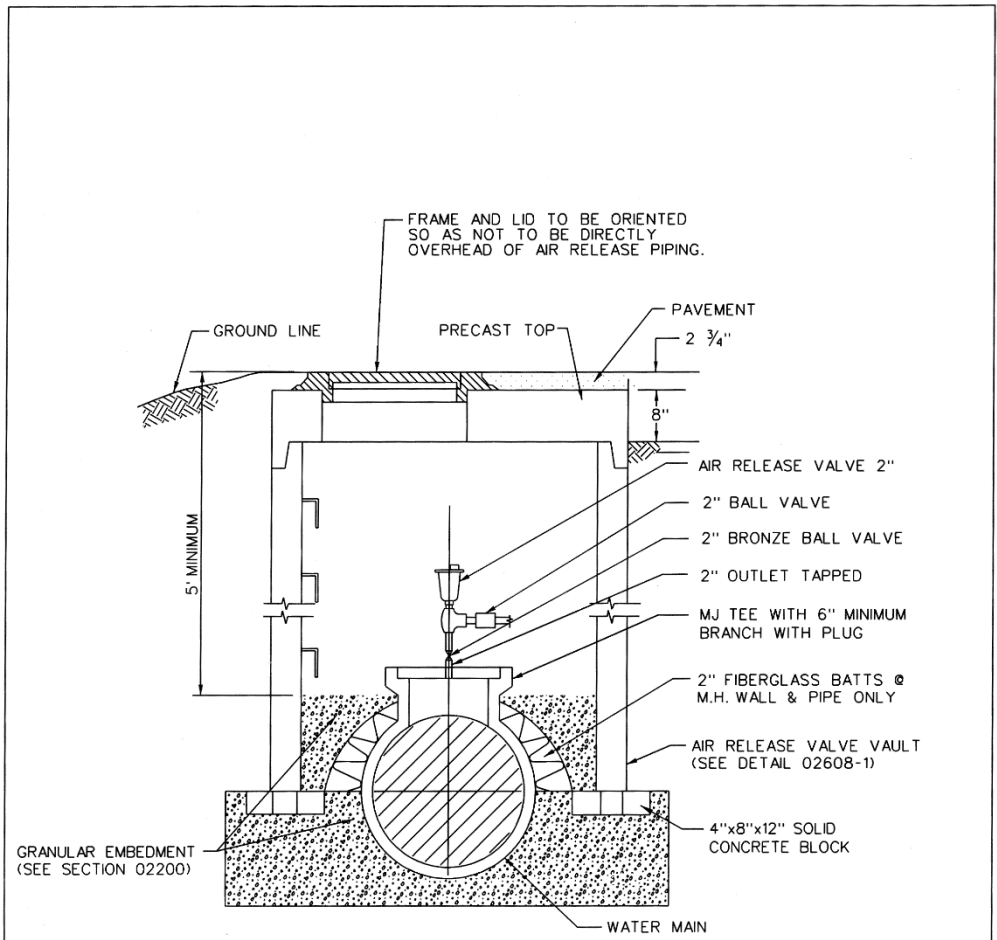

NOTES:

1. THE ABOVE PIPING, FITTINGS AND VALVES ARE FOR MAINS 16 INCHES AND LARGER.
2. FOR VAULT SEE DETAIL 02608-1.
3. ALL NIPPLES ARE TO BE BRASS.

<b>TYPICAL AIR RELEASE 2" OR SMALLER</b>	
<b>16" MAINS AND LARGER</b>	
WATER SERVICES DEPARTMENT    CITY OF KANSAS CITY, MISSOURI	
REVISED: APRIL, 2013	CONSTRUCTION DETAIL DRAWING NO. 02641-2

...Air\_Release\_det43013.dgn 5/7/2013 4:27:34 PM

DEETER FOUNDRY PRODUCT NO.1194  
 MANHOLE RING & SOLID COVER  
 WITH "WATER KCMO" LETTERS  
 AND FOUNTAIN LEGEND.  
 PROVIDE COVER WITH NINE  
 1-INCH DIA. HOLES FOR AIR FLOW.

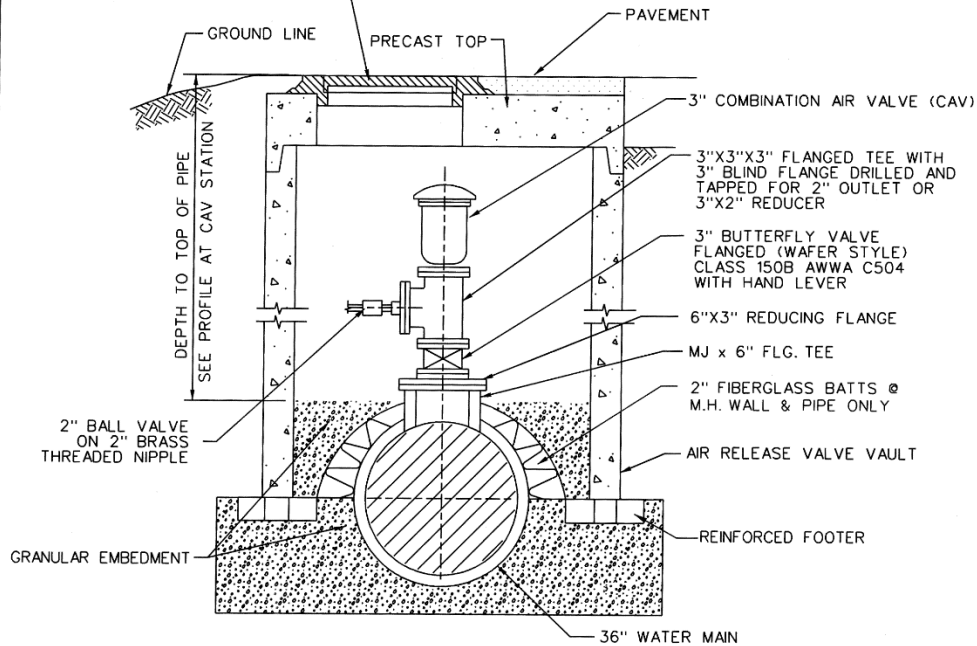

NOTES:

1. FOR VAULT DETAILS, SEE SECTION 02608, KCMO WSD STANDARDS AND SPECIFICATIONS AND ASTM C478. TOP, RISER, & FOOTERS, SHALL BE SUITABLE FOR TRAFFIC CONDITIONS AND DESIGNED TO MEET H-20 WHEEL LOAD REQUIREMENTS.
2. BRASS PIPING SHALL BE ASTM B43, EXTRA STRONG W/ ASME 816.1 CLASS 250 FITTINGS
3. CAV TO BE A.R.I. FLOW CONTROL CAV MODEL NO. D-060-C HF OR APPROVED EQUAL.
4. WHERE VAULT IS INSTALLED OUTSIDE OF PAVEMENT LIMITS, PROVIDE MINIMUM 12" OF SOIL ABOVE VAULT TOP FOR RESTORATION OF GRASS OR LANDSCAPE FEATURES AND GRADE TO MATCH ADJACENT EXISTING SURFACE.

TYPICAL AIR RELEASE 3" OR LARGER  
 16" MAINS AND LARGER

WATER SERVICES DEPARTMENT CITY OF KANSAS CITY, MISSOURI

REVISED: APRIL 2013 CONSTRUCTION DETAIL DRAWING NO. 02641-2B

...13-INCH CAV DETAIL Rev42913 dgn 5/7/2013 4:09:27 PM

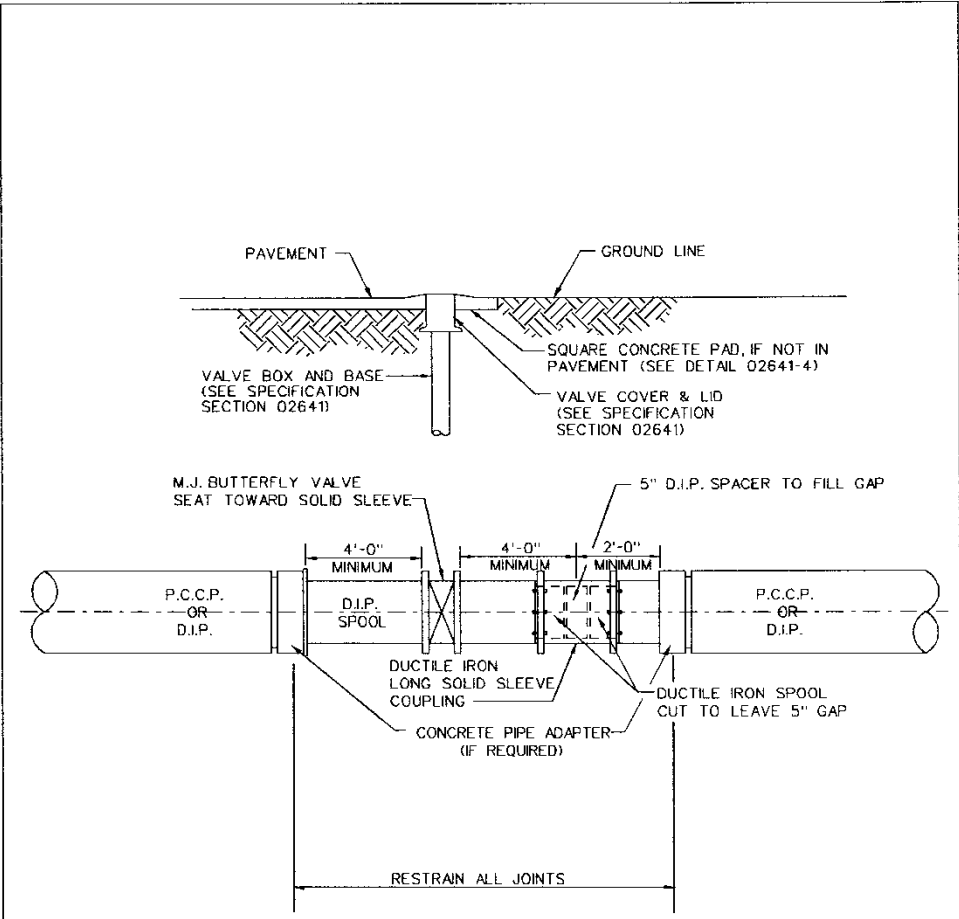

- NOTES:
1. TORQUE LIMITERS TO BE PLACED ON ALL BUTTERFLY VALVES.
  2. ALL PIPE AND BOLTS TO BE PAINTED WITH ONE COAT COAL TAR EPOXY AFTER ASSEMBLY.
  3. RESTRAIN ALL JOINTS BETWEEN ADAPTERS.

<b>TYPICAL BUTTERFLY VALVE INSTALLATION</b>	
WATER SERVICES DEPARTMENT	CITY OF KANSAS CITY, MISSOURI
	DRAWING NO. 19808
REVISED: MARCH, 2011	CONSTRUCTION DETAIL NO. 02641-3

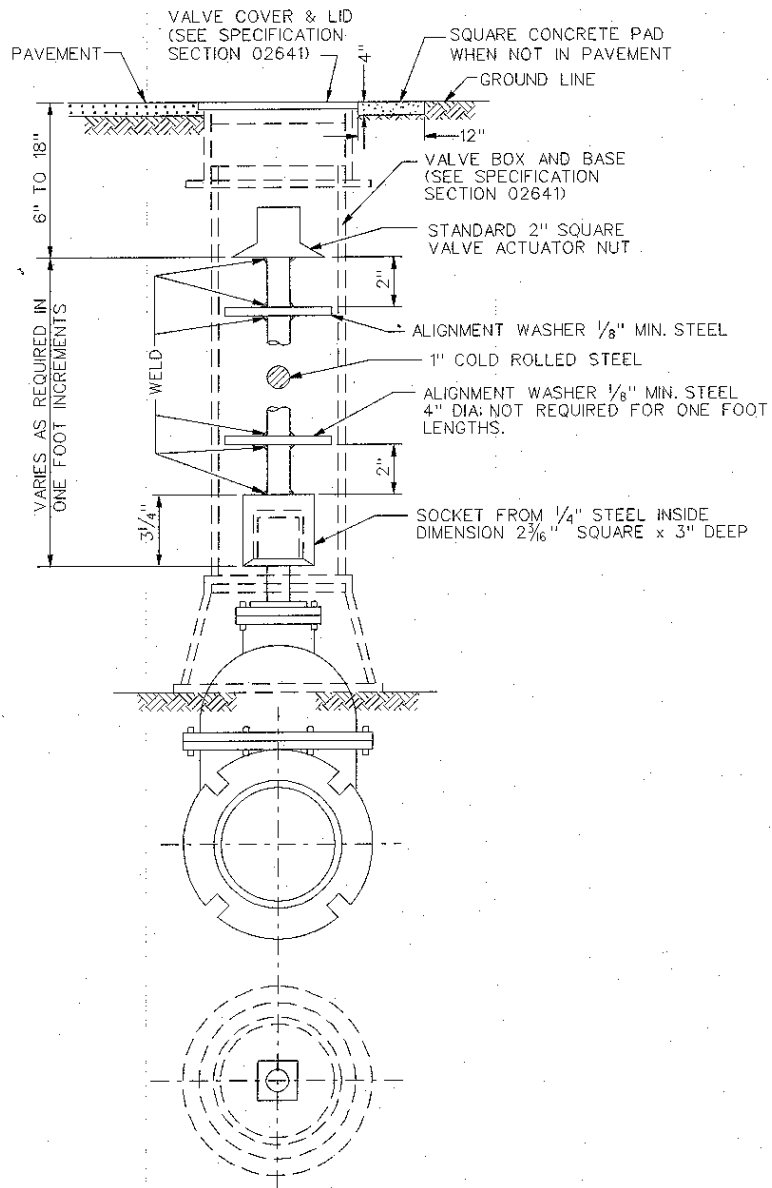

**ACTUATOR NUT EXTENSION**

**WATER SERVICES DEPARTMENT CITY OF KANSAS CITY, MISSOURI**

REVISED: FEBRUARY, 2003 CONSTRUCTION DETAIL DRAWING NO. 02641-4

## **SECTION 02645M – HYDRANTS AND FLUSHING ASSEMBLIES**

### **PART 1 - GENERAL**

#### **1.01 SUMMARY**

- A. This section provides requirements for the furnishing and installation of hydrants and flushing assemblies associated with maintenance activities.

#### **1.02 SPECIFICATION MODIFICATIONS**

- A. It is understood that throughout this section these Specifications may be modified by appropriate items in Section 01015 – Specific Project Requirements or as otherwise indicated on the Contract Drawings.

#### **1.03 RELATED SECTIONS**

- A. Section 01000 – General Project Requirements.
- B. Section 01015 – Specific Project Requirements.
- C. Section 02250M – Trenching, Pipe Embedment and Backfill.
- D. Section 02669M – Thrust Restraints.

#### **1.04 CODES AND STANDARDS**

- A. The publications listed below form a part of this specification to the extent referenced. The publications are referred to within the text by the basic designation only.
- B. American Water Works Associations (AWWA):
  - AWWA C111/A21.11-17 Rubber-Gasket Joints for Ductile-Iron Pressure Pipe and Fittings.
  - AWWA C502 Dry-Barrel Fire Hydrants.

#### **1.05 DEFINITIONS**

- A. Bury line: The location on the lower barrel of the hydrant that intersects with the finished grade.
- B. Cover: The distance from the ground line to the top of the connecting pipe.
- C. Hydrant Trench Depth: The distance from the bottom of the hydrant base to the finished grade (bury line).

#### **1.06 MATERIALS PROVIDED BY THE CITY**

- A. The City will provide Contractor with hydrant assemblies.

#### **1.07 QUALITY ASSURANCE**

- A. The Contractor is responsible for the quality assurance and quality control of the Work.

#### **1.08 PRODUCT DELIVERY, STORAGE AND HANDLING**

- A. Follow the provisions for delivery, storage, protection, and handling Products to the site and on site as provided in Section 01000 – General Project Requirements.
- B. After the units on site, inspect for damage and inventory.

- C. Packaging:
  - 1. All hydrants shall be bundled in a group no larger than three (3) hydrants wide by three (3) hydrants high. All hydrants shall be shipped with the hydrant base inlet pointing down. All hydrants shall be separated wood framing adequate to prevent the hydrants from touching the ground or each other. Binding the hydrants together shall be a band or wrap adequate to per handling of the hydrant bundles with a crane truck or a forklift. All hydrants shall be delivered with the hydrant nozzle cap installed.
- D. Delivery:
  - 1. All hydrants shall be available for pickup from the City's Yard Store, 2409 E. 18<sup>th</sup> Street, Kansas City, Missouri, 64127.
- E. Hydrants shall be the current Kansas City, Missouri pattern hydrants manufactured specifically for the City of Kansas City, Missouri.
  - 1. Bonnet sections:
    - (a) Field painted bonnet sections:
      - (i) Reference paragraph HYDRANT INSTALLATION.
      - (ii) Hydrants connected to mains less than 6-inches.:
        - a. Contractor applied.
        - b. Red (Krylon 5814 or approved equal).
        - c. Gloss finish.
      - (iii) Hydrants connected to mains equal to 6-inches and less than 12-inches:
        - a. Manufacturer applied black, gloss finish.
      - (iv) Hydrants connected to mains 12-inches or larger mains:
        - a. Contractor applied.
        - b. Green (Krylon 5816 or approved equal).
        - c. Gloss finish.
    - 2. This color-coding is intended to provide firefighters and other emergency workers a permanent, quick visual reference to indicate the size of water main connected to each hydrant.

## PART 2 - EXECUTION

### 2.01 EXCAVATION

- A. Excavation shall be in conformance with Section 02250M – Trenching, Pipe Embedment and Backfill.

### 2.02 HYDRANT INSTALLATION

- A. Layout:
  - 1. Hydrants shall be installed so that there is a minimum clear area of 5 feet in all directions to allow for operation of hydrant. Notify City's representative if the minimum clear distance cannot be met.
  - 2. The Contractor shall furnish all labor and material in laying out the work.
  - 3. If it is necessary to change the location of a hydrant from the current location, then the City shall approve the staked location of each hydrant before its installation.
- B. The weep holes of the hydrant shall be kept clear and free to drain.
- C. Place 1-½ cubic yards of stone fill as indicated on the standard details.
- D. Hydrant Trench Depth: Five (5) feet unless otherwise indicated.

- E. Hydrants shall stand plumb.
  - F. When placed along roadways the centerline of the hydrant shall be as follows:
    - 1. A minimum of twenty-four (24) inches from the back of the curb.
    - 2. A minimum of 4 feet from the edge of pavement where no curb exists.
  - G. Setting of Hydrants:
    - 1. Hydrants shall be set so that the breakaway (traffic) flange is installed at the manufacturer's recommend height above finished grade (which is the top of the pavement in paved areas).
    - 2. Unless otherwise indicated on the Drawings the Contractor shall set the height of the traffic flange as follows:
      - (a) Using an offset fitting or other combination of fittings between the valve and hydrant base.
  - H. Hydrants shall not be set in a drainage ditches.
  - I. Hydrant shall be rotated so as to have the nozzle facing the street. If site conditions dictate, at the direction of the City, the hydrant shall be rotated to face another direction.
  - J. Hydrants are to be installed with mechanical joint anchoring fittings or approved restraint devices. Refer to Section 02669M – Thrust Restraints.
  - K. Hydrants are to be installed in accordance with the following standard Construction Detail Drawings:
    - 1. 02645-1 – Typical Hydrant Installation with 90 Degree Bend (Type “A” Setting).
    - 2. 02645-2 – Straight Set Hydrant Installation (Type “B” Setting).
    - 3. 02645-3 – Typical Hydrant Set in Back-slope.
  - L. After installation and before hydrants are placed in service, Contractor shall field apply two separate coats of all surface spray enamel paint, in accordance with paint manufacturers recommendations, to completely cover each hydrant bonnet in accordance with paragraph HYDRANT COLOR CODING.
- 2.03 FLUSHING ASSEMBLIES
- A. Flushing assemblies shall be installed in accordance with the following standard Construction Detail Drawings:
    - 1. 02645-4 – Typical Flushing Assembly, 12-inch Mains and Smaller.
- 2.04 POLYETHYLENE ENCASMENT
- A. Polyethylene encasement shall be installed on all ductile iron pipe, fittings, valves and other appurtenances including the hydrant sets.
  - B. Install polyethylene encasement to the bury line of fire hydrants.
  - C. Cut holes in the polyethylene encasement at the base of fire hydrants to allow drainage from the weep holes into the underlying stone fill.
- 2.05 BACKFILL AND COMPACTION
- A. The areas around each hydrant valve shall be thoroughly compacted to prevent settlement of these areas.
  - B. Backfill and compaction shall be in accordance with Section 02250M – Trenching, Pipe Embedment and Backfill.

DETAILS ON THE NEXT SIX PAGES

DETAIL 02645-1

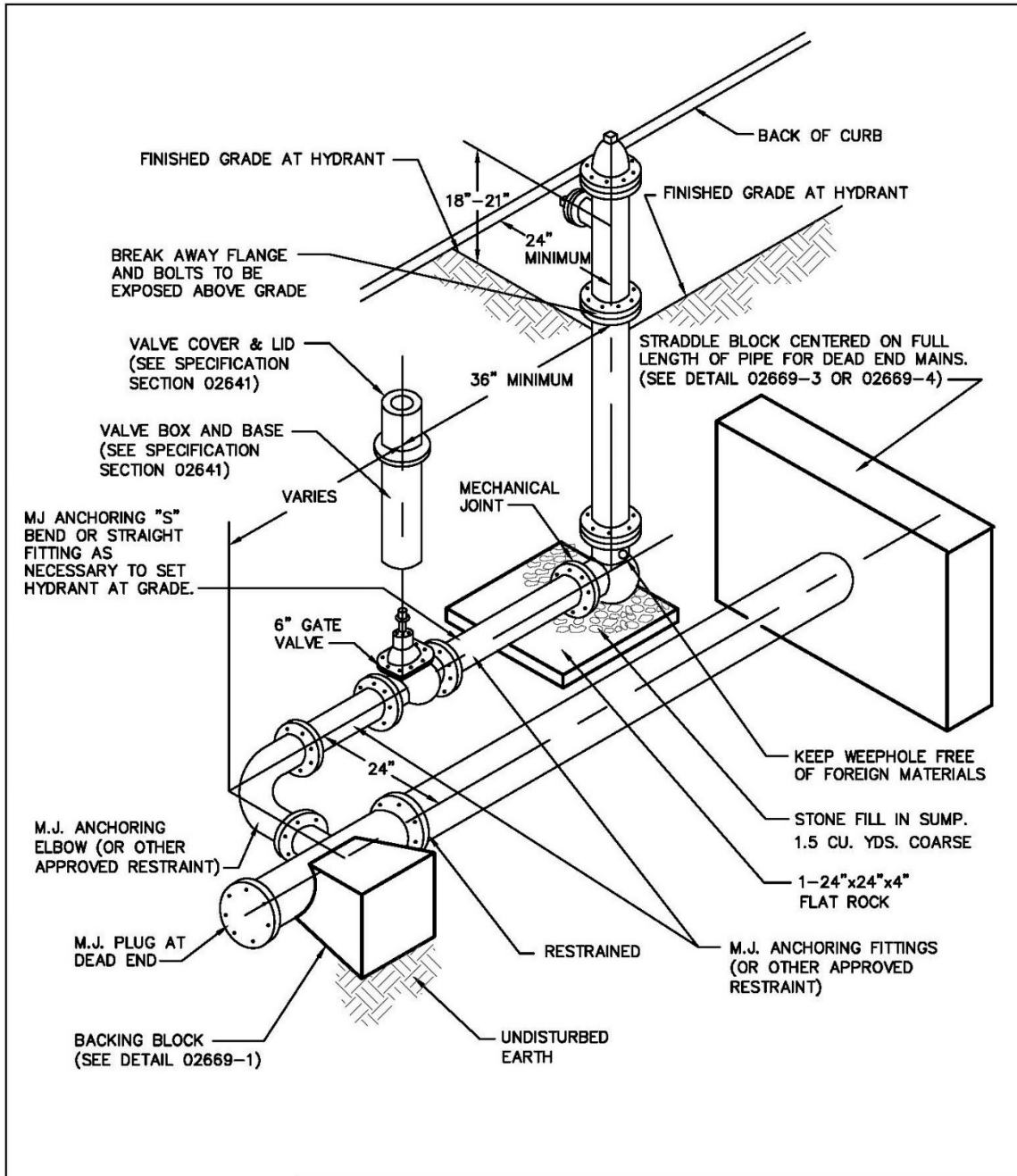

TYP. HYDRANT INSTALL. WITH 90° BEND  
(TYPE "A" SETTING)

WATER SERVICES  
CITY OF KANSAS CITY, MISSOURI

DRAWING NO. 02645-1

DEVELOPED BY: TECHNICAL ADVISORY COMMITTEE

APPROVED BY:

DATE: 12/10/2020

1 OF 1



DETAIL 02645-2

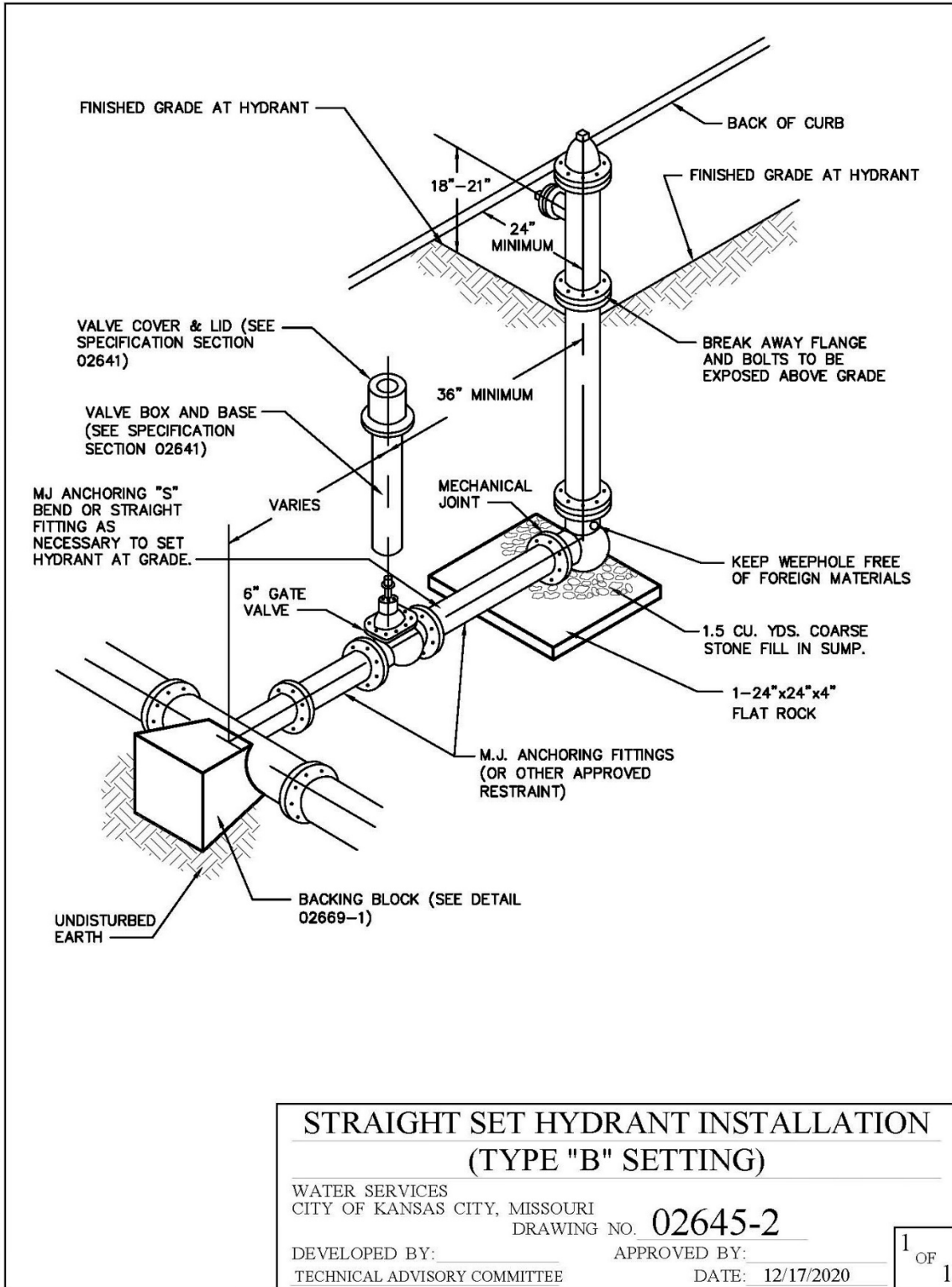

**STRAIGHT SET HYDRANT INSTALLATION  
(TYPE "B" SETTING)**

WATER SERVICES  
CITY OF KANSAS CITY, MISSOURI  
DRAWING NO. **02645-2**

DEVELOPED BY: \_\_\_\_\_ APPROVED BY: \_\_\_\_\_  
TECHNICAL ADVISORY COMMITTEE DATE: 12/17/2020

1 OF 1

DETAIL 02645-3

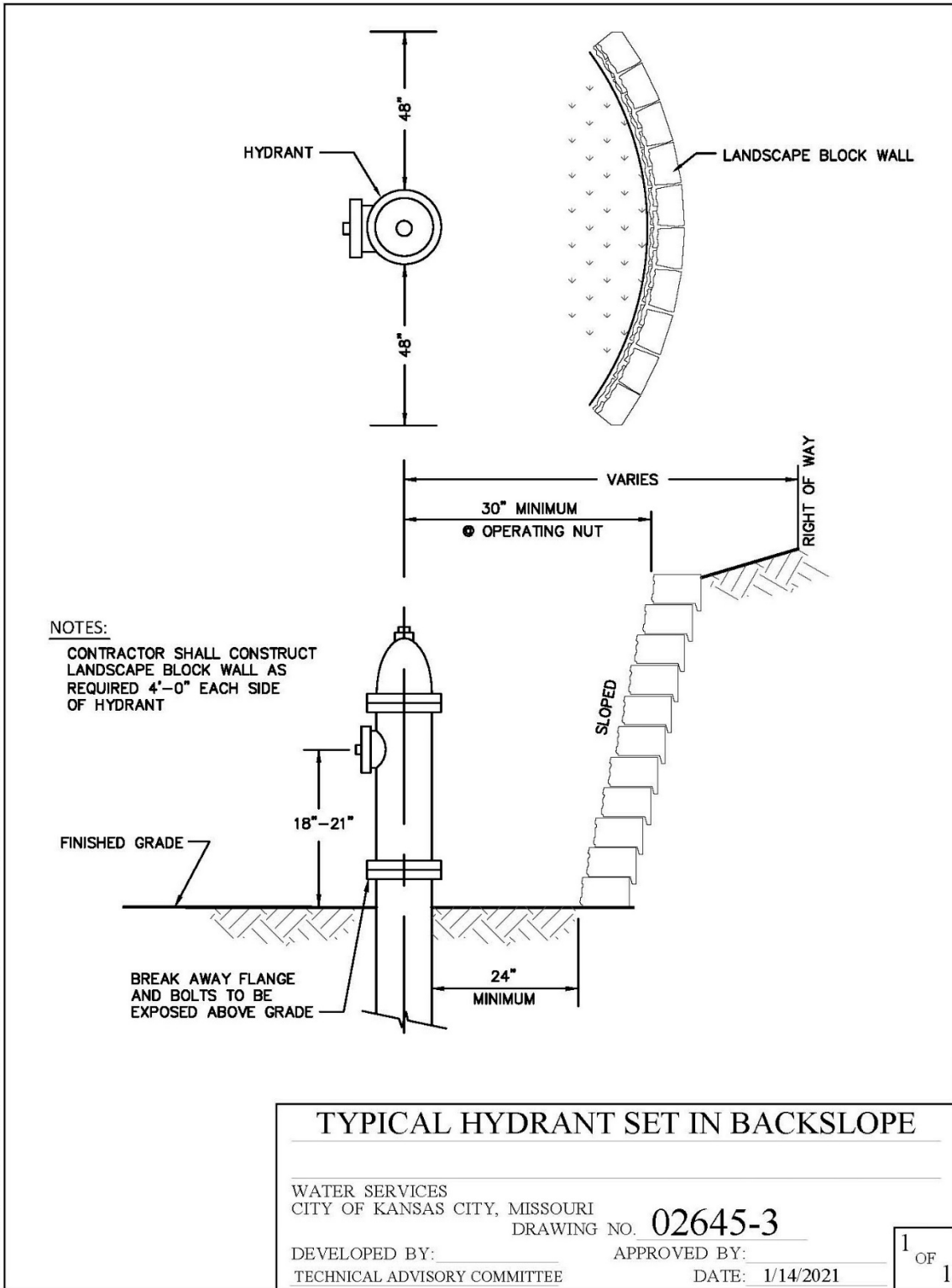

DETAIL 02645-4

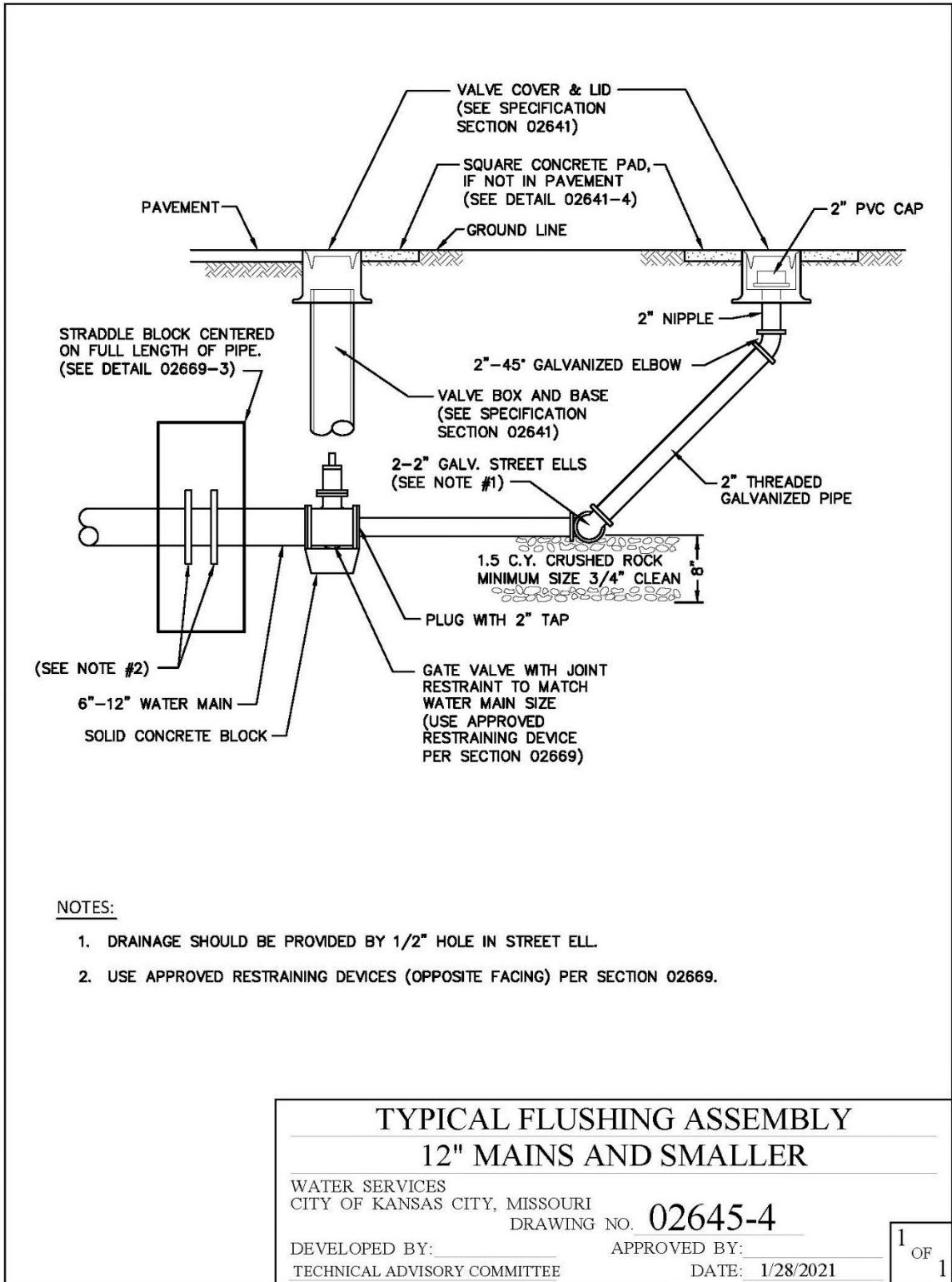

DETAIL 02645-5

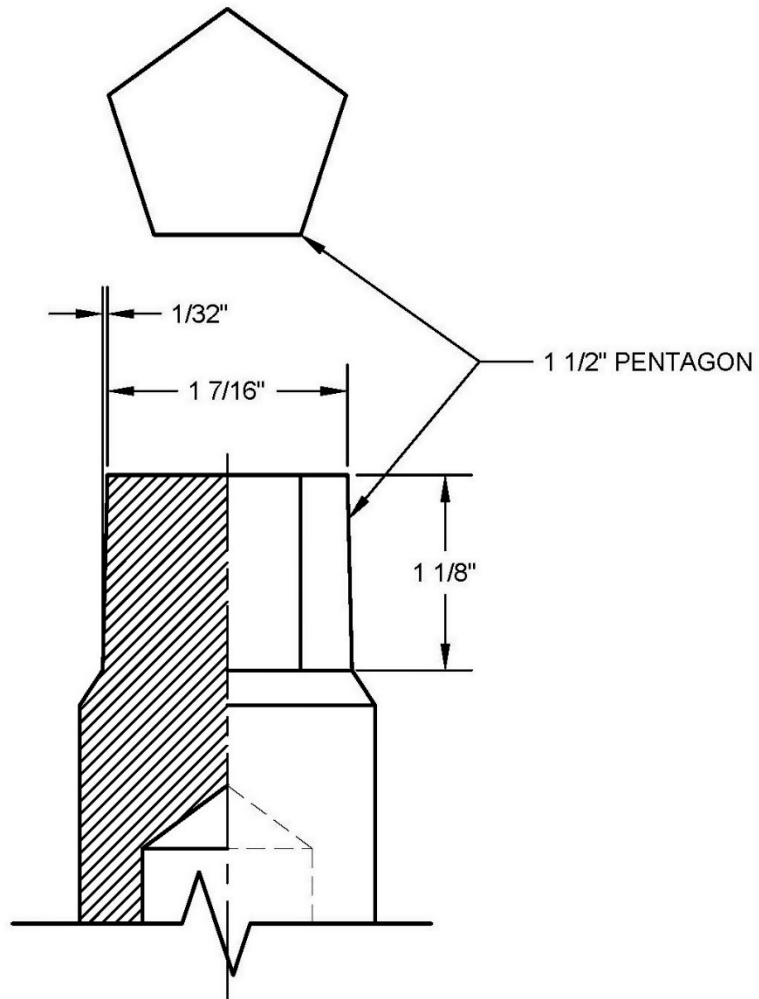

**OPERATING NUT (STEM NUT)**

WATER SERVICES  
CITY OF KANSAS CITY, MISSOURI

DRAWING NO. **02645-5**

DEVELOPED BY: \_\_\_\_\_  
TECHNICAL ADVISORY COMMITTEE

APPROVED BY: \_\_\_\_\_  
DATE: 12/16/2020

1 OF 1

Detail 02645-6

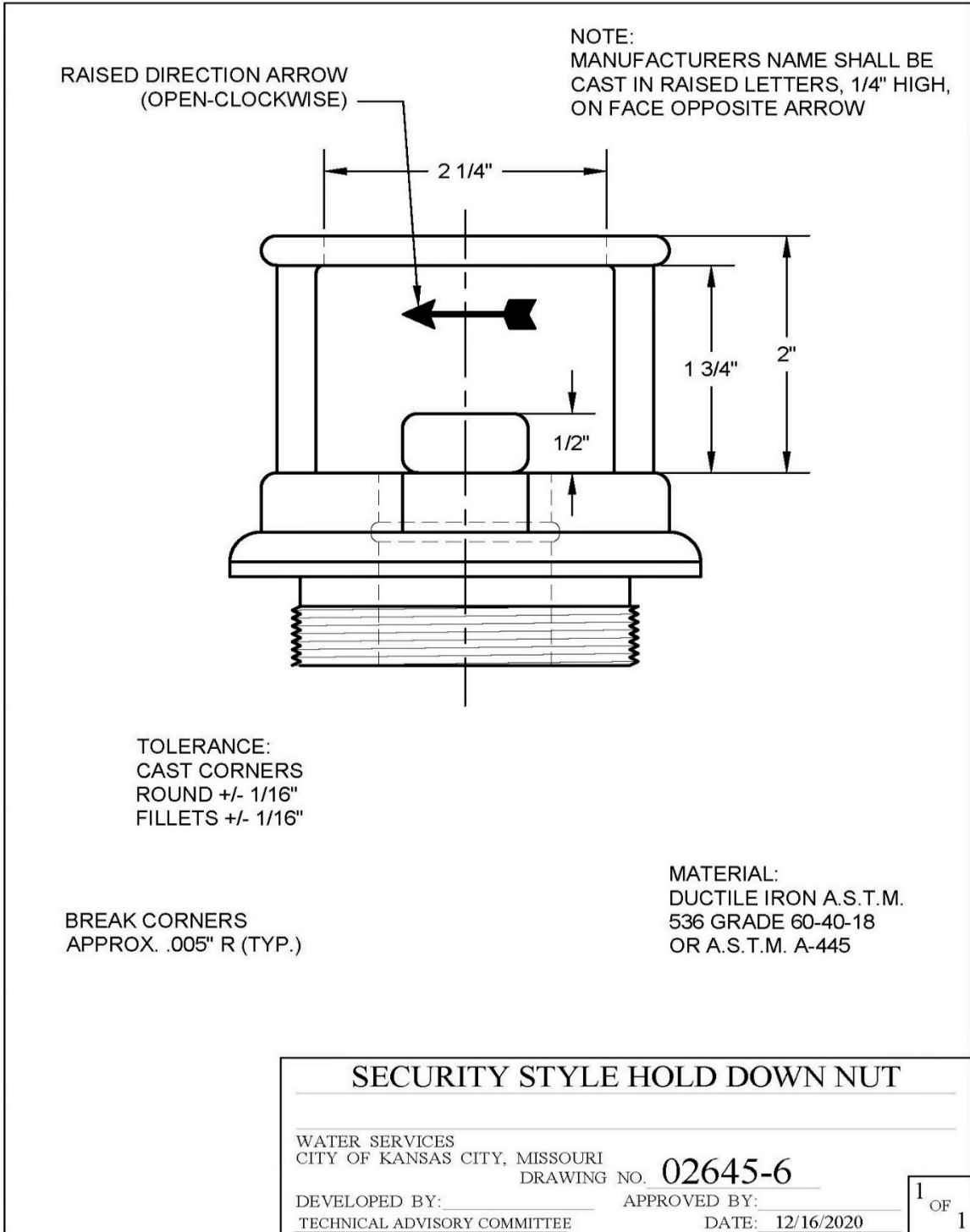

END OF SECTION

## SECTION 02669M – THRUST RESTRAINTS

### PART 1 - GENERAL

#### 1.01 SUMMARY

- A. This section provides for the required restraining devices to prevent the movement of pipe and fittings for work associated with maintenance activities.
- B. This section includes Restrained Joints and Concrete Blocking (backing blocks and straddle blocks).
- C. The specifications for concrete and appurtenances provided in this section only pertain to thrust restraint of water mains.

#### 1.02 SPECIFICATION MODIFICATIONS

- A. It is understood that throughout this section these Specifications may be modified by appropriate items in Section 01015 – Specific Project Requirements, or as otherwise indicated on the Contract Drawings.

#### 1.03 RELATED SECTIONS

- A. Section 01000 – General Project Requirements.
- B. Section 01015 – Specific Project Requirements.

#### 1.04 CODES AND STANDARDS

- A. The publications listed below form a part of this specification to the extent referenced. The publications are referred to within the text by the basic designation only.
- B. American Society for Testing and Materials (ASTM):
  - ASTM A615 Standard Specification for Deformed and Plain Carbon-Steel Bars for Concrete Reinforcement.
  - ASTM A616 Standard Specification for Rail-Steel Deformed and Plain Carbon-Steel Bars for Concrete Reinforcement.
- C. City of Kansas City, Missouri Department of Public Works Construction and Material Specifications (<http://kcmo.gov/publicworks/design-construction-standards/>):
  - KCMO PW 2208 Subsection Section 2208, Portland Cement Concrete Pavement.

#### 1.05 INFORMATION PROVIDED BY THE CITY

- A. As provided in the Contract Documents.

#### 1.06 SUBMITTALS

- A. Shop Drawings:
  - 1. Submit shop drawings and descriptive details showing the size, length, and location of each fitting and adjacent pipe, and the details of all anchorage and harnessing proposed.
- B. Other:
  - 1. Concrete Mix Design. See paragraph 2.04, part A.

1.07 QUALITY ASSURANCE

- A. The manufacturer shall be a company specializing in manufacturing the Products specified in this section with minimum three (3) years documented experience.

1.08 PRODUCT DELIVERY, STORAGE AND HANDLING

- A. Follow the provisions for the delivery, storage, protection and handling products to and on site as provided in Section 01000 – General Project Requirements.
- B. Concrete Mix Design: In accordance with KCMO PW 2208, a mix design, for all concrete mixes to be used, shall be submitted to the City in accordance with paragraph SUBMITTALS. As a minimum the following information must be in the Quality Management file for the plant or included with the mix design:
  - 1. Mix design designation required by project.
  - 2. Project name, location, project number and date.
  - 3. Name and location of ready mix plant or plants.
  - 4. List the source and type of all materials from each plant supplying mix.
  - 5. CA and FA Sieve Analysis and quality checks from each plant supplying mix. CA-Ledge, quarry or mine name and location. FA- Sand plant name, location and source (MO or Kaw River) (less than 6 months old).
  - 6. ASR test results (less than 2 years old).
  - 7. Durability Factor test results for CA (less than 2 years old).
  - 8. Cement chemical analysis.
  - 9. Specific gravity of all materials.
  - 10. The mix design shall be based on one cubic yard of concrete or one cubic meter if required.
  - 11. The mix design shall contain the weight and volume of each mix component (S.S.D.).
  - 12. The results of 28-day compressive strengths shall be submitted when requested by the City.

PART 2 - PRODUCTS

2.01 RESTRAINED PUSH-ON JOINTS FOR DUCTILE IRON PIPE

- A. Flex-Ring® as manufactured by American Ductile Iron Pipe.
- B. Fast-Grip® as manufactured by American Ductile Iron Pipe.
- C. Super-Lock® as manufactured by McWane.
- D. TR Flex® as manufactured by McWane.
- E. Field Lok® as manufactured by McWane.
- F. Snap-Lok® as manufactured by Griffin Pipe Products.

2.02 RESTRAINED MECHANICAL JOINTS FOR DUCTILE IRON PIPE

- A. MEGALUG® as manufactured by EBAA Iron, Inc. MEGALUG.
- B. Uni-Flange® as manufactured by The Ford Meter Box Company, Inc.
- C. Restrained joint fittings: One Bolt.
- D. Restrained mechanical joints shall not be used on plain end fittings.

2.03 CONCRETE BLOCKING

- A. Concrete:
  - 1. Concrete shall conform to KCMO PW 2208 except as follows:

- (a) Limestone may be used as coarse aggregate.
  - (b) Design strength of concrete shall be 4,500 psi or greater.
  - (c) Slump shall be 4 inches.
  - (d) Coarse Aggregate: 1-inch maximum.
  - (e) Air entrainment admixture is required.
  - (f) Water reducing admixture is required.
2. Ready mix concrete shall be supplied by a plant approved by the KCMO Public Works Department according to the Ready Mix Concrete Quality Management Plan. Submit ready mix concrete plant information in accordance with paragraph SUBMITTALS when requested by City.
  3. Submit concrete mix design in accordance with KCMO PW 2208.C and in accordance with the paragraph SUBMITTALS.
- B. Water for mixing and curing concrete shall be potable.
- C. Reinforcing Steel:
1. Reinforcing steel bars shall conform to the requirements of the following Standards and Grades:
    - (a) ASTM A615: Grade 40 or 60.
    - (b) ASTM A616: Grade 50 or 60.
- D. Forms:
1. Suitable and substantial forms shall be provided. All forms shall be constructed and maintained plumb and true to line, securely braced, tied, clamped and shored, and tight enough to prevent leakage of concrete.
  2. Where applicable, undisturbed earth may be used in lieu of forms.
  3. The deflection of the forms due to the weight of plastic concrete, placing equipment, and workmen shall be accurately figured and taken into account in the design of the forms so that finished concrete members will have surfaces, lines, planes, and elevations required within tolerances in accordance with ACI 117.
  4. Forms for walls and thrust restraints shall be designed structurally for the rate of placement of concrete.
  5. All forms shall be removed prior to backfill unless the following conditions are met:
    - (a) As directed by the City.
    - (b) When constructed of unbrace plywood have a thickness of ½-inch or less, removal shall be optional unless otherwise directed by the City.
  6. Forms shall be constructed so that they can be removed without damage to the concrete.
- E. Formwork Accessories:
1. Forms shall be securely braced and tied with approved form ties that do not leave any parts within ¾ inch of the surface of the concrete. Wire ties and wood spreaders will not be permitted.

## PART 3 - EXECUTION

### 3.01 REACTION ANCHORAGE AND BLOCKING

- A. Piping and fittings with push-on or mechanical joints, or similar joints subject to internal pressure shall be blocked, anchored, or harnessed to preclude separation of joints.



- B. All push-on and mechanical joint bends deflecting 11-1/4 degrees or more shall be provided with suitable blocking, anchors, joint harness, or other acceptable means for preventing movement of the pipe caused by internal pressure.
- C. Concrete backing blocks shall extend from the fitting to solid undisturbed earth and shall be installed so that all joints and bolts are accessible for repair.
- D. Standard Dimensions and Details: The City's standard details for backing blocks are provided for three (3) ranges of soil resistance. The dimensions of backing blocks shall be as indicated on the following details:
  - 1. 2,000 PSF Soil Resistance: Unless otherwise indicated on the Drawings or in Section 01015 – Specific Project Requirements, backing blocks shall be constructed in accordance with the following details:
    - (a) Detail 02669-1 – Typical Backing Blocks for Tees and Plugs (2,000 PSF Soil Resistance).
    - (b) Detail 02669-2 – Typical Backing Blocks for Horizontal Bends (2,000 PSF Soil Resistance).
    - (c) Detail 02669-3 – Typical Straddle Block for 6 and 8-inch Pipe (2,000 PSF Soil Resistance).
    - (d) Detail 02669-4 – Typical Straddle Block for 12 and 16-inch Pipe (2,000 PSF Soil Resistance).
    - (e) Detail 02669-5 – Typical Straddle Block for 20, 24 and 30-inch Pipe (2,000 PSF Soil Resistance).
  - 2. 2,500 PSF Soil Resistance: When the Design Professional can justify through geotechnical investigation, laboratory testing and analysis that the soil conditions within the project area meet or exceed a 2,500 pounds per square foot soil resistance, the backing blocks may be constructed in accordance with the following details. These details may only be used if noted on the Drawings or in Section 01015 – Specific Project Requirements:
    - (a) Detail 02669-6 – Alternate Backing Blocks for Tees and Plugs (2,500 PSF Soil Resistance).
    - (b) Detail 02669-7 – Alternate Backing Blocks for Horizontal Bends (2,500 PSF Soil Resistance).
    - (c) Detail 02669-8 – Alternate Straddle Block for 6 and 8-inch Pipe (2,500 PSF Soil Resistance).
    - (d) Detail 02669-9 – Alternate Straddle Block for 12 and 16-inch Pipe (2,500 PSF Soil Resistance).
    - (e) Detail 02669-10 – Alternate Straddle Block for 20, 24 and 30-inch Pipe (2,500 PSF Soil Resistance).
  - 3. 3,000 PSF Soil Resistance: When the Design Professional can justify through geotechnical investigation, laboratory testing and analysis that the soil conditions within the project area meet or exceed a 3,000 pounds per square foot soil resistance, the backing blocks may be constructed in accordance with the following details. These details may only be used only if noted on the Drawings or in Section 01015 – Specific Project Requirements:
    - (a) Detail 02669-11 – Alternate Backing Blocks for Tees and Plugs (3,000 PSF Soil Resistance).
    - (b) Detail 02669-12 – Alternate Backing Blocks for Horizontal Bends (3,000 PSF Soil Resistance).
    - (c) Detail 02669-13 – Alternate Straddle Block for 6 and 8-inch Pipe (3,000 PSF Soil Resistance).

- (d) Detail 02669-14 – Alternate Straddle Block for 12 and 16-inch Pipe (3,000 PSF Soil Resistance).
- (e) Detail 02669-15 – Alternate Straddle Block for 20, 24 and 30-inch Pipe (3,000 PSF Soil Resistance).

### 3.02 CONCRETE AND REINFORCING STEEL

#### A. Placing of Reinforcing Steel:

1. Before being installed in the final position, all metal reinforcements shall be free of mud, clay, ice, grease, oil, loose rust and scale, and other coatings that would reduce or destroy the bond.
2. Metal reinforcements shall be accurately formed and positioned to the required dimensions.
3. Steel reinforcements shall be accurately positioned as required and shall be secured against displacement by using annealed wire ties or suitable clips at all intersections.
4. The steel reinforcements shall be supported by metal supports, spacers, or hangers.
5. The legs on the metal chair supports shall be plastic coated.

#### B. Forms:

1. Verify lines, levels and centers before proceeding with formwork.
2. A coat of non-staining oil, lacquer, or other approved material shall be applied to protect form surface and to facilitate stripping. Coating shall be applied in strict accordance with the directions of the manufacturer.
3. Forms shall be removed in such manner as to assure the complete safety of the structure. In no case shall supporting forms or shoring be removed until the concrete has acquired sufficient strength.

#### C. Placing of Concrete:

1. Only those methods and arrangements of equipment shall be used which will reduce to a minimum any segregation of coarse aggregate from the concrete.
2. Every consideration shall be given to the proper placement of all concrete and the proper care of all concrete after placement.
3. Concrete shall be deposited into the forms or on the grade as nearly as practicable in its final position and in such manner that the concrete will completely fill the forms.
4. Vibration shall not be used to move concrete in a horizontal direction after initial placement.
5. Concrete that has partially hardened or has been contaminated by foreign material shall not be deposited in the Work and shall be removed from the Site at no additional cost to the City.
6. When inclined chutes beyond the mixer are permitted by the City, a baffle shall be provided at the bottom end so that concrete will drop vertically without segregation.
7. No water shall be added to the concrete for any reason at the job site that will result in exceeding the specified water-cement ratio.
8. Care shall be taken to assure proper concrete coverage of reinforcing steel as designed.
9. Placement operations shall be performed in such a manner as to prevent loose earth falling into the excavation during placement of concrete.

10. Concrete that might contact forms or reinforcing steel during placement shall be placed by the use of trunks or pipes whenever the drop exceeds six (6) feet for unexposed work, or three (3) feet for exposed work.
  11. When trunks or pipe are used, they shall be located at horizontal spacing of not to exceed ten (10) feet.
  12. Concrete for thrust restraints shall be placed in horizontal layers not exceeding two (2) feet in depth.
  13. Placing of concrete in thrust restraints shall be done in such manner as to prevent "cold joints," both horizontally and vertically.
- D. Vibrating:
1. Mechanical internal vibrators shall be used whenever possible in all formed concrete work.
  2. Vibrators shall be inserted at uniform spacing of twelve (12) inches to twenty (20) inches to assure thorough consolidation of all concrete.
  3. Vibrators shall be inserted and withdrawn vertically to a depth, which will assure penetration into the previous lift with vibration periods of from five (5) to fifteen (15) seconds.
  4. Form vibration and/or hand spading will be required at points inaccessible for thorough internal vibration.
  5. During placement of concrete, stand-by vibrators shall be immediately available in the event of mechanical failure in the vibrators being used.

### 3.03 RESTRAINED JOINTS

- A. Use of restrained joints shall be as indicated on the Drawings.
- B. Length of restrained joints shall be as indicated on the Drawings.
- C. Differing subsurface or physical conditions: If the Contractor or City's Representative discovers during performance of the Work that support for a backing block against undisturbed soil cannot be obtained, then use of restrained joint pipe may be necessary. Refer to Section 00700 – General Conditions, Article 4:
  1. The Contractor shall notify the City that a restrained joint may be required.
  2. The Design Professional or the City shall provide the Contractor with the required length of restrained joints.
  3. Calculations for the required length of restrained pipe shall be subject to approval by the City.

### 3.04 BACKFILL

- A. To aid in the curing of concrete, a maximum of eight (8) inches of un-compacted backfill material may be placed over the concrete backing block.
- B. No compaction shall occur or additional backfill placed over the backing block until the concrete has been in place for at least one (1) day.

### 3.05 SUPPORT FOR FITTINGS

- A. Backing blocks, anchorages, or other supports for fittings installed in fills or other unstable ground, above grade, or exposed within structures, shall be provided as shown on the Drawings, required by the Construction Detail Drawings and as directed by the City.

3.06 EXTERIOR COATINGS

- A. All clamps, rods, bolts, and other metal accessories used in reaction anchorages, or joint harness subject to submergence or contact with earth or other fill material and not encased in concrete shall be protected from corrosion by two coats of approved coal tar epoxy applied in the field to clean, dry metal surfaces. The first coat shall be dry and hard before the second coat is applied.
- B. Metal surfaces exposed above grade or within vaults shall be painted with one prime coat and two finish coats of a paint acceptable to the City.

DETAILS 02669-1 THROUGH 02669-15  
ARE ON THE FOLLOWING 15 PAGES

DETAIL 02669-1

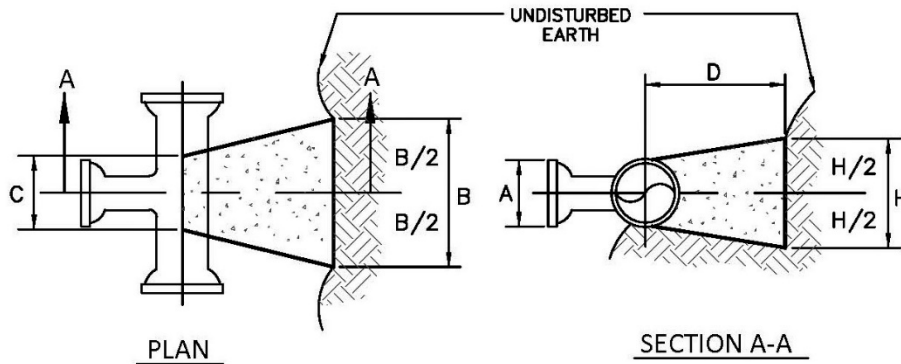

NOTES:

1. BACKING BLOCKS FOR PIPING SIZES UP THROUGH 12-INCH ARE BASED ON WORKING PRESSURE OF 175 P.S.I. PLUS 50% SURGE.
2. BACKING BLOCKS FOR PIPING SIZES 16-INCH THROUGH 24-INCH ARE BASED ON A WORKING PRESSURE OF 150 P.S.I. PLUS 50% SURGE.
3. THE PROJECT DESIGN PROFESSIONAL IS RESPONSIBLE FOR THE DESIGN OF THRUST BLOCKS. THE BLOCK SIZES SPECIFIED HEREIN ARE MINIMUM SIZES, BASED ON SOIL RESISTANCE OF 2,000 POUNDS PER SQUARE FOOT. WHERE SOFTER SOILS MAY BE ENCOUNTERED, THE PROJECT DESIGN PROFESSIONAL MUST PROVIDE A DESIGN FOR REVIEW BY THE DEPARTMENT.

BRANCH OR PLUG SIZE A	B (in.)	C (in.)	D (in.)	H (in.)	REQUIRED BEARING AREA (SQ.FT.)	ESTIMATED CONCRETE REQ. CYD.
6"	46	6	20	24	7.4	0.24
8"	60	8	26	32	13.2	0.55
12"	114	12	51	38	29.7	2.45
16"	126	16	55	52	45.2	4.00
20"	140	20	60	72	70.7	6.74
24"	184	24	80	80	101.8	13.00
30"	230	30	100	100	159.0	25.61

**TYPICAL BACKING BLOCKS FOR TEES AND PLUGS**  
**2,000 POUNDS PER SQUARE FOOT SOIL RESISTANCE**

WATER SERVICES  
 CITY OF KANSAS CITY, MISSOURI

DRAWING NO. **02669-1**

DEVELOPED BY: \_\_\_\_\_  
 TECHNICAL ADVISORY COMMITTEE

APPROVED BY: \_\_\_\_\_

DATE: 1/13/2021

1 OF 1

DETAIL 02669-2

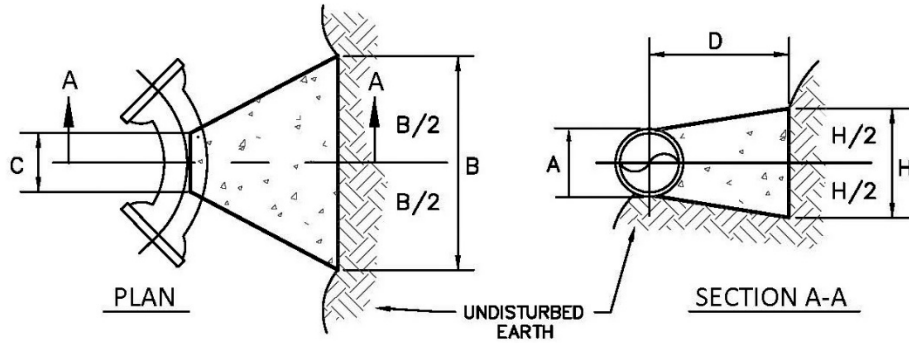

NOTES:

1. BACKING BLOCKS FOR PIPING SIZES UP THROUGH 12-INCH ARE BASED ON WORKING PRESSURE OF 175 P.S.I. PLUS 50% SURGE.
2. BACKING BLOCKS FOR PIPING SIZES 16-INCH THROUGH 24-INCH ARE BASED ON A WORKING PRESSURE OF 150 P.S.I. PLUS 50% SURGE.
3. THE PROJECT DESIGN PROFESSIONAL IS RESPONSIBLE FOR THE DESIGN OF THRUST BLOCKS. THE BLOCK SIZES SPECIFIED HEREIN ARE MINIMUM SIZES, BASED ON SOIL RESISTANCE OF 2,000 POUNDS PER SQUARE FOOT. WHERE SOFTER SOILS MAY BE ENCOUNTERED, THE PROJECT DESIGN PROFESSIONAL MUST PROVIDE A DESIGN FOR REVIEW BY THE DEPARTMENT.

11° DEGREE BENDS						
PIPE SIZE A	B (in.)	C (in.)	D (in.)	H (in.)	REQUIRED BEARING AREA (SQ.FT.)	ESTIMATED CONCRETE REQ. CYD.
6"	18	6	12	12	1.5	0.03
8"	28	8	12	14	2.6	0.06
12"	38	12	13	22	5.8	0.14
16"	50	16	17	26	8.9	0.28
20"	64	20	22	32	13.9	0.58
24"	76	24	26	38	20.0	0.97
30"	95	30	33	48	31.2	1.90

22° DEGREE BENDS						
PIPE SIZE A	B (in.)	C (in.)	D (in.)	H (in.)	REQUIRED BEARING AREA (SQ.FT.)	ESTIMATED CONCRETE REQ. CYD.
6"	28	6	12	16	2.9	0.06
8"	34	8	13	22	5.1	0.11
12"	56	12	22	30	11.6	0.43
16"	72	16	28	36	17.7	0.85
20"	86	20	33	46	27.6	1.54
24"	106	24	41	54	39.7	2.77
30"	136	30	53	66	62.1	5.60

45° DEGREE BENDS						
PIPE SIZE A	B (in.)	C (in.)	D (in.)	H (in.)	REQUIRED BEARING AREA (SQ.FT.)	ESTIMATED CONCRETE REQ. CYD.
6"	38	6	16	22	5.7	0.15
8"	54	8	23	28	10.1	0.39
12"	82	12	35	40	22.7	1.28
16"	100	16	42	50	34.6	2.37
20"	130	20	55	60	54.1	4.83
24"	152	24	64	74	77.9	8.10
30"	196	30	83	90	121.7	16.49

90° DEGREE BENDS						
PIPE SIZE A	B (in.)	C (in.)	D (in.)	H (in.)	REQUIRED BEARING AREA (SQ.FT.)	ESTIMATED CONCRETE REQ. CYD.
6"	60	6	27	26	10.5	0.46
8"	84	8	38	32	18.7	1.12
12"	126	12	57	44	42.0	3.47
16"	160	16	72	58	64.0	7.36
20"	200	20	90	72	100.0	14.27
24"	242	24	109	86	143.9	24.98
30"	324	30	147	100	224.9	52.46

TYP. BACKING BLOCKS FOR HORIZONTAL BENDS  
2,000 POUNDS PER SQUARE FOOT SOIL RESISTANCE

WATER SERVICES  
CITY OF KANSAS CITY, MISSOURI

DRAWING NO. 02669-2

DEVELOPED BY: \_\_\_\_\_  
TECHNICAL ADVISORY COMMITTEE

APPROVED BY: \_\_\_\_\_

DATE: 1/13/2021

1 OF 1

DETAIL 02669-3

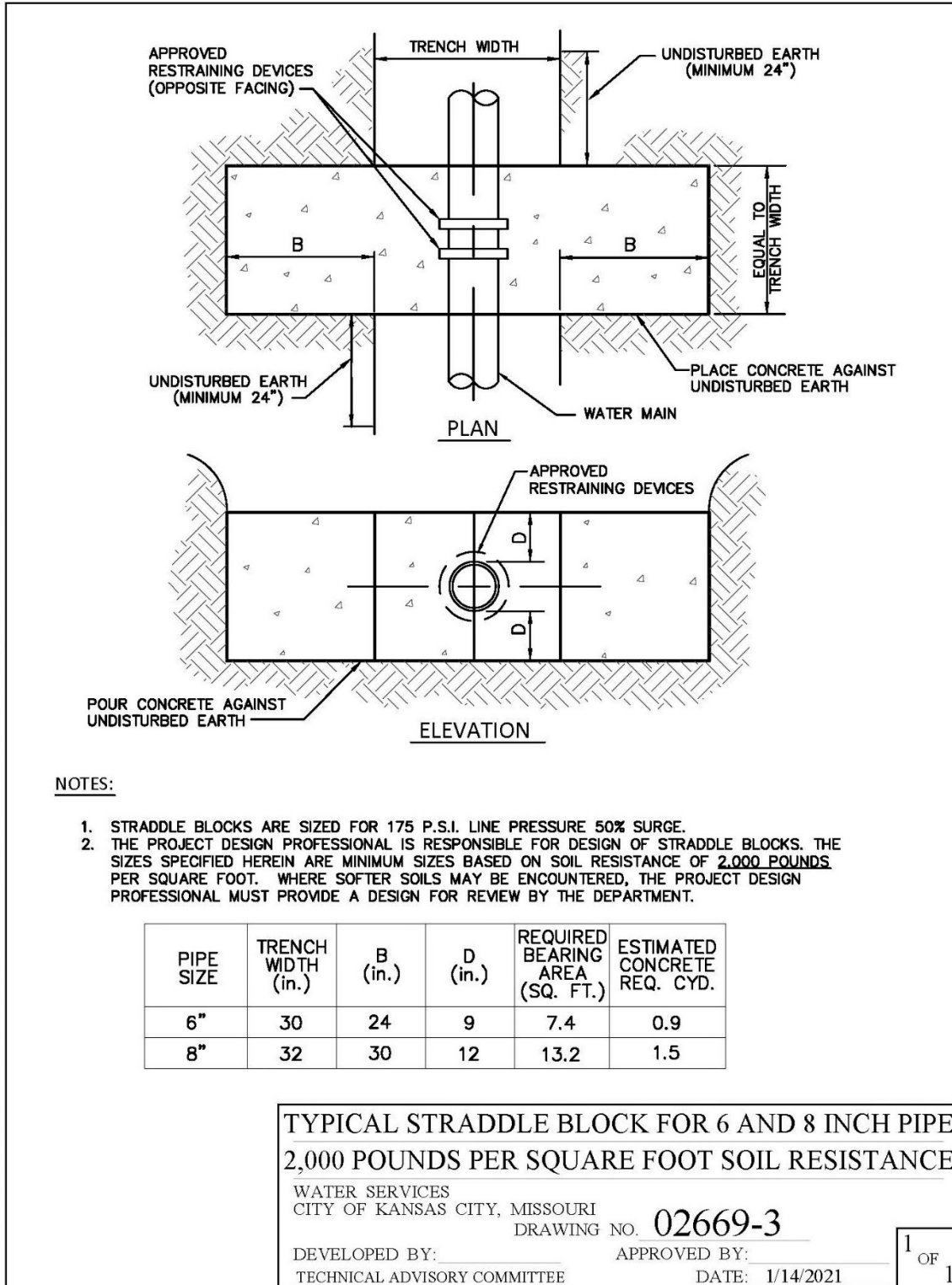

DETAIL 02669-4

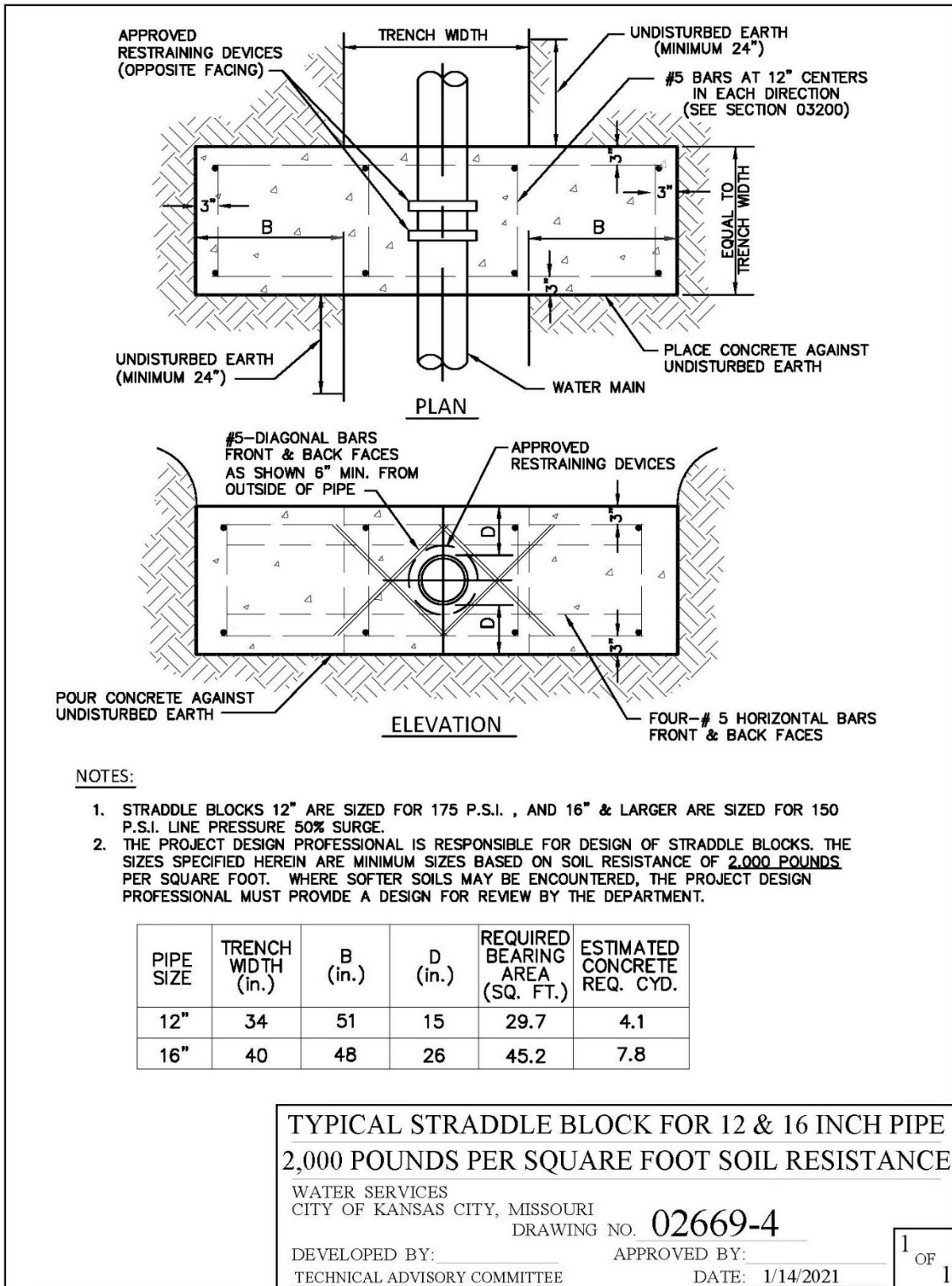



DETAIL 02669-5

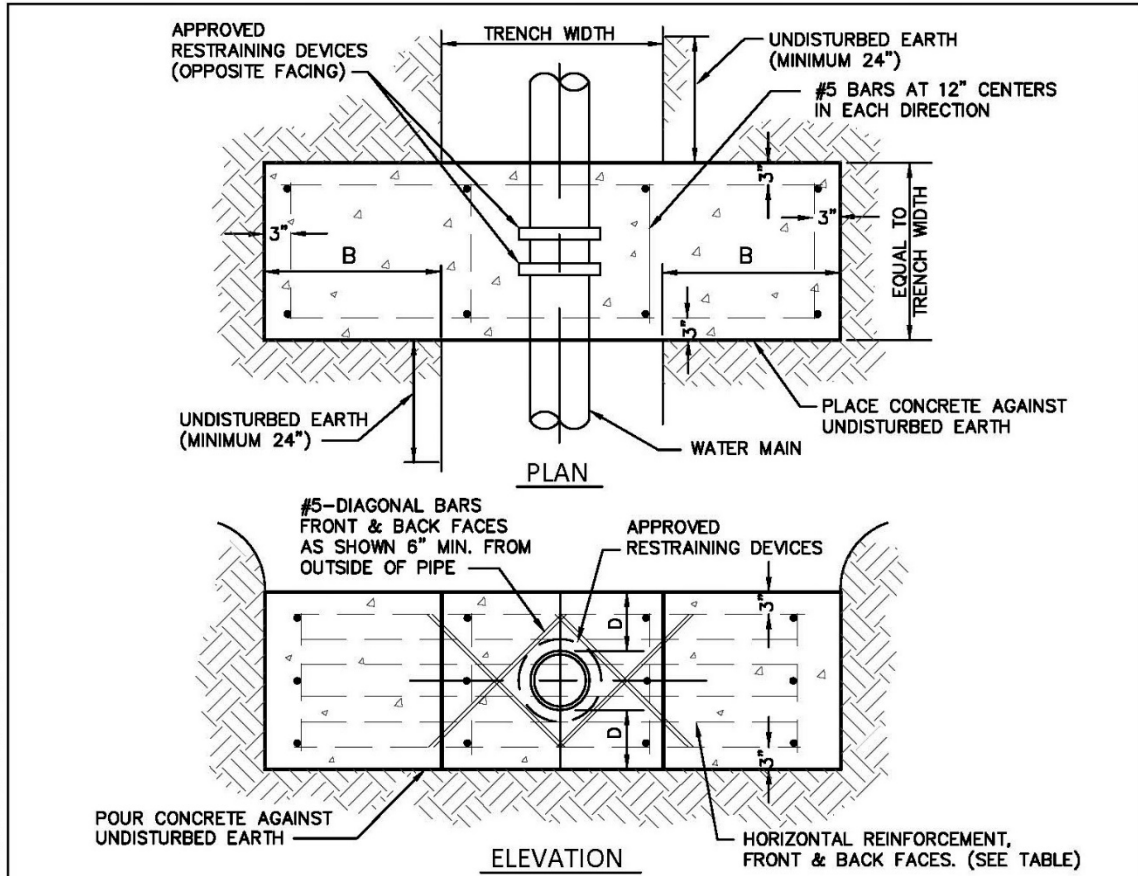

NOTES:

1. STRADDLE BLOCKS ARE SIZED FOR 150 P.S.I. LINE PRESSURE 50% SURGE.
2. THE PROJECT DESIGN PROFESSIONAL IS RESPONSIBLE FOR DESIGN OF STRADDLE BLOCKS. THE SIZES SPECIFIED HEREIN ARE MINIMUM SIZES BASED ON SOIL RESISTANCE OF 2,000 POUNDS PER SQUARE FOOT. WHERE SOFTER SOILS MAY BE ENCOUNTERED, THE PROJECT DESIGN PROFESSIONAL MUST PROVIDE A DESIGN FOR REVIEW BY THE DEPARTMENT.

PIPE SIZE	BAR SIZE	NO. OF BARS (each face)	TRENCH WIDTH (in.)	B (in.)	D (in.)	REQUIRED BEARING AREA (SQ. FT.)	ESTIMATED CONCRETE REQ. CYD.
20"	#5	5	44	71	26	70.7	12.3
24"	#6	6	48	92	28	101.8	18.6
30"	#7	6	60	115	35	159.0	36.4

**TYP. STRADDLE BLOCK FOR 20, 24, & 30 INCH PIPE**  
**2,000 POUNDS PER SQUARE FOOT SOIL RESISTANCE**

WATER SERVICES  
 CITY OF KANSAS CITY, MISSOURI  
 DRAWING NO. **02669-5**

DEVELOPED BY: \_\_\_\_\_ APPROVED BY: \_\_\_\_\_  
 TECHNICAL ADVISORY COMMITTEE DATE: 1/14/2021

DETAIL 02669-6

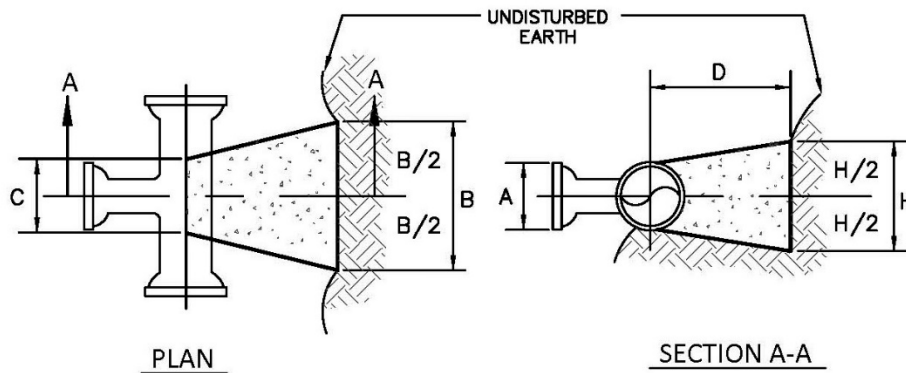

NOTES:

1. BACKING BLOCKS FOR PIPING SIZES UP THROUGH 12-INCH ARE BASED ON WORKING PRESSURE OF 175 P.S.I. PLUS 50% SURGE.
2. BACKING BLOCKS FOR PIPING SIZES 16-INCH THROUGH 24-INCH ARE BASED ON A WORKING PRESSURE OF 150 P.S.I. PLUS 50% SURGE.
3. THE PROJECT DESIGN PROFESSIONAL IS RESPONSIBLE FOR THE DESIGN OF THRUST BLOCKS. THE BLOCK SIZES SPECIFIED HEREIN ARE MINIMUM SIZES, BASED ON SOIL RESISTANCE OF 2,500 POUNDS PER SQUARE FOOT. WHERE SOFTER SOILS MAY BE ENCOUNTERED, THE PROJECT DESIGN PROFESSIONAL MUST PROVIDE A DESIGN FOR REVIEW BY THE DEPARTMENT.

BRANCH OR PLUG SIZE A	B (in.)	C (in.)	D (in.)	H (in.)	REQUIRED BEARING AREA (SQ.FT.)	ESTIMATED CONCRETE REQ. CYD.
6"	48	6	21	18	5.9	0.20
8"	60	8	26	26	10.6	0.45
12"	96	12	42	36	23.8	1.62
16"	110	16	47	48	36.2	2.79
20"	140	20	60	60	56.5	5.76
24"	180	24	78	66	81.4	10.41
30"	220	30	95	84	127.2	19.73

**ALT. BACKING BLOCKS FOR TEES AND PLUGS**  
**2,500 POUNDS PER SQUARE FOOT SOIL RESISTANCE**

WATER SERVICES  
 CITY OF KANSAS CITY, MISSOURI  
 DRAWING NO. **02669-6**

DEVELOPED BY: \_\_\_\_\_ APPROVED BY: \_\_\_\_\_  
 TECHNICAL ADVISORY COMMITTEE DATE: 1/13/2021

1 OF 1

DETAIL 02669-7

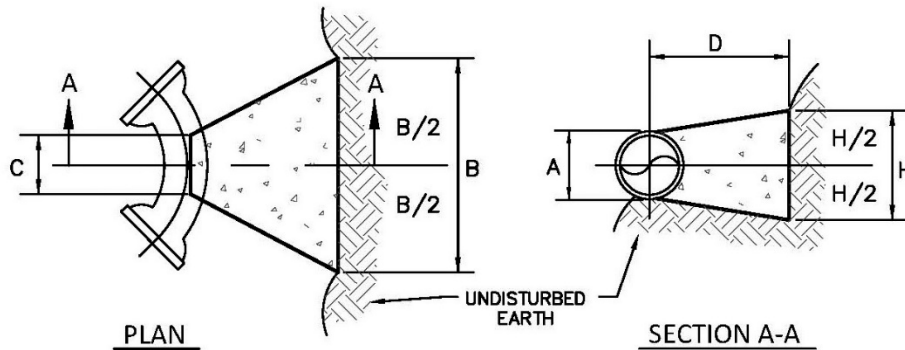

NOTES:

1. BACKING BLOCKS FOR PIPING SIZES UP THROUGH 12-INCH ARE BASED ON WORKING PRESSURE OF 175 P.S.I. PLUS 50% SURGE.
2. BACKING BLOCKS FOR PIPING SIZES 16-INCH THROUGH 24-INCH ARE BASED ON A WORKING PRESSURE OF 150 P.S.I. PLUS 50% SURGE.
3. THE PROJECT DESIGN PROFESSIONAL IS RESPONSIBLE FOR THE DESIGN OF THRUST BLOCKS. THE BLOCK SIZES SPECIFIED HEREIN ARE MINIMUM SIZES, BASED ON SOIL RESISTANCE OF 2,500 POUNDS PER SQUARE FOOT. WHERE SOFTER SOILS MAY BE ENCOUNTERED, THE PROJECT DESIGN PROFESSIONAL MUST PROVIDE A DESIGN FOR REVIEW BY THE DEPARTMENT.

11° DEGREE BENDS						
PIPE SIZE A	B (in.)	C (in.)	D (in.)	H (in.)	REQUIRED BEARING AREA (SQ.FT.)	ESTIMATED CONCRETE REQ. CYD.
6"	18	6	12	12	1.5	0.032
8"	28	8	12	14	2.6	0.059
12"	36	12	12	20	5.8	0.100
16"	40	16	12	26	8.9	0.167
20"	56	20	18	30	13.9	0.401
24"	64	24	20	36	20.0	0.617
30"	90	30	30	40	31.2	1.447

22° DEGREE BENDS						
PIPE SIZE A	B (in.)	C (in.)	D (in.)	H (in.)	REQUIRED BEARING AREA (SQ.FT.)	ESTIMATED CONCRETE REQ. CYD.
6"	24	6	12	16	2.3	0.050
8"	28	8	12	20	4.1	0.091
12"	46	12	19	28	9.3	0.341
16"	78	16	24	32	14.1	0.593
20"	86	20	35	36	22.1	1.365
24"	96	24	36	48	31.8	2.000
30"	142	30	52	54	49.6	4.534

45° DEGREE BENDS						
PIPE SIZE A	B (in.)	C (in.)	D (in.)	H (in.)	REQUIRED BEARING AREA (SQ.FT.)	ESTIMATED CONCRETE REQ. CYD.
6"	34	6	14	20	4.5	0.11
8"	46	8	19	26	8.1	0.26
12"	80	12	34	34	18.2	1.00
16"	100	16	42	40	27.7	1.90
20"	116	20	48	54	43.3	3.40
24"	150	24	63	60	62.3	6.50
30"	168	30	69	84	97.4	11.10

90° DEGREE BENDS						
PIPE SIZE A	B (in.)	C (in.)	D (in.)	H (in.)	REQUIRED BEARING AREA (SQ.FT.)	ESTIMATED CONCRETE REQ. CYD.
6"	52	6	23	24	8.4	0.32
8"	78	8	35	28	14.9	0.84
12"	122	12	55	40	33.6	3.00
16"	144	16	64	52	51.2	5.30
20"	180	20	80	64	80.0	10.20
24"	208	24	92	80	115.2	17.00
30"	288	30	129	90	179.9	37.10

**ALT. BACKING BLOCKS FOR HORIZONTAL BENDS**  
**2,500 POUNDS PER SQUARE FOOT SOIL RESISTANCE**

WATER SERVICES  
 CITY OF KANSAS CITY, MISSOURI

DRAWING NO. **02669-7**

DEVELOPED BY: \_\_\_\_\_  
 TECHNICAL ADVISORY COMMITTEE

APPROVED BY: \_\_\_\_\_  
 DATE: 1/13/2021

1 OF 1

DETAIL 02669-8

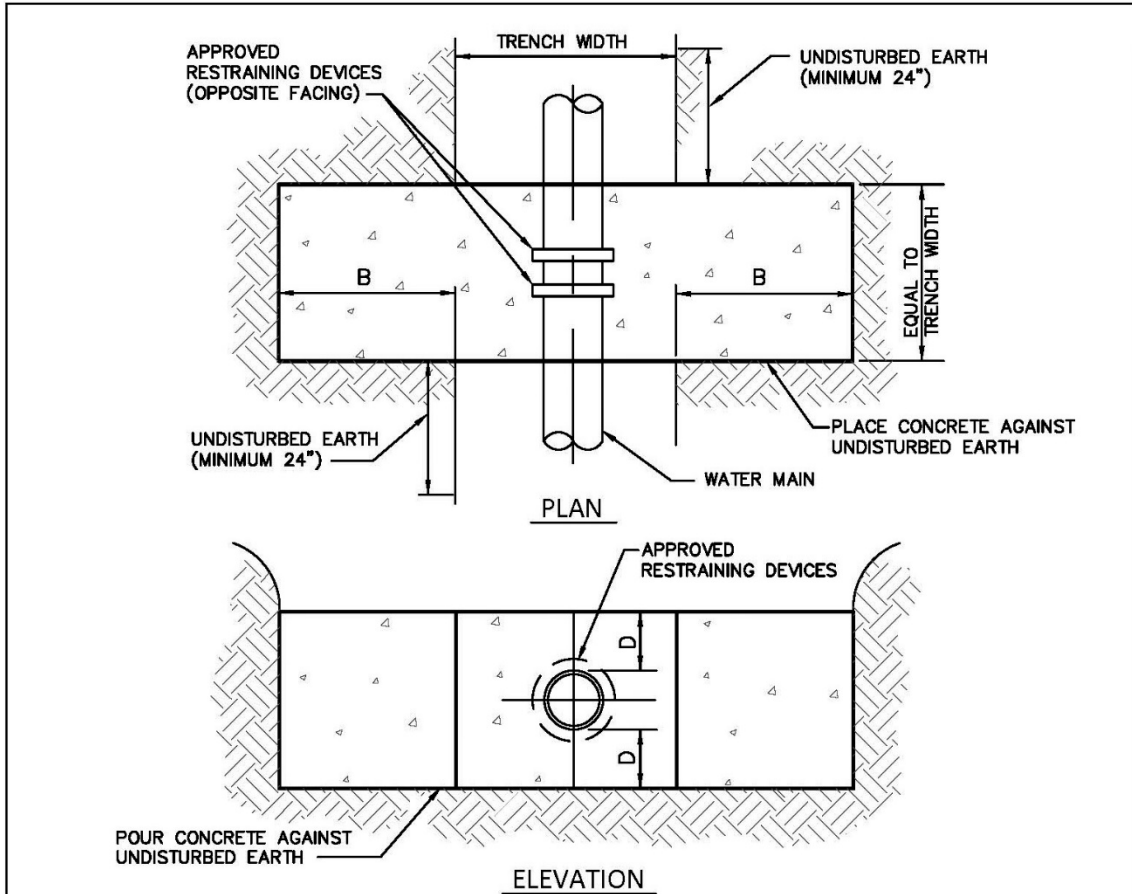

NOTES:

1. STRADDLE BLOCKS ARE SIZED FOR 175 P.S.I. LINE PRESSURE 50% SURGE.
2. THE PROJECT DESIGN PROFESSIONAL IS RESPONSIBLE FOR DESIGN OF STRADDLE BLOCKS. THE SIZES SPECIFIED HEREIN ARE MINIMUM SIZES BASED ON SOIL RESISTANCE OF 2,500 POUNDS PER SQUARE FOOT. WHERE SOFTER SOILS MAY BE ENCOUNTERED, THE PROJECT DESIGN PROFESSIONAL MUST PROVIDE A DESIGN FOR REVIEW BY THE DEPARTMENT.

PIPE SIZE	TRENCH WIDTH (in.)	B (in.)	D (in.)	REQUIRED BEARING AREA (SQ. FT.)	ESTIMATED CONCRETE REQ. CYD.
6"	30	24	6	5.9	0.71
8"	32	32	8	10.6	1.16

THIS DETAIL TO BE USED ONLY IF SPECIFIED BY PROJECT DESIGN PROFESSIONAL ON APPROVED FOR CONSTRUCTION DRAWINGS.

**ALT. STRADDLE BLOCK FOR 12 & 16 INCH PIPE**  
**2,500 POUNDS PER SQUARE FOOT SOIL RESISTANCE**

WATER SERVICES  
 CITY OF KANSAS CITY, MISSOURI  
 DRAWING NO. **02669-8**

DEVELOPED BY: \_\_\_\_\_ APPROVED BY: \_\_\_\_\_  
 TECHNICAL ADVISORY COMMITTEE DATE: 1/14/2021

DETAIL 02669-9

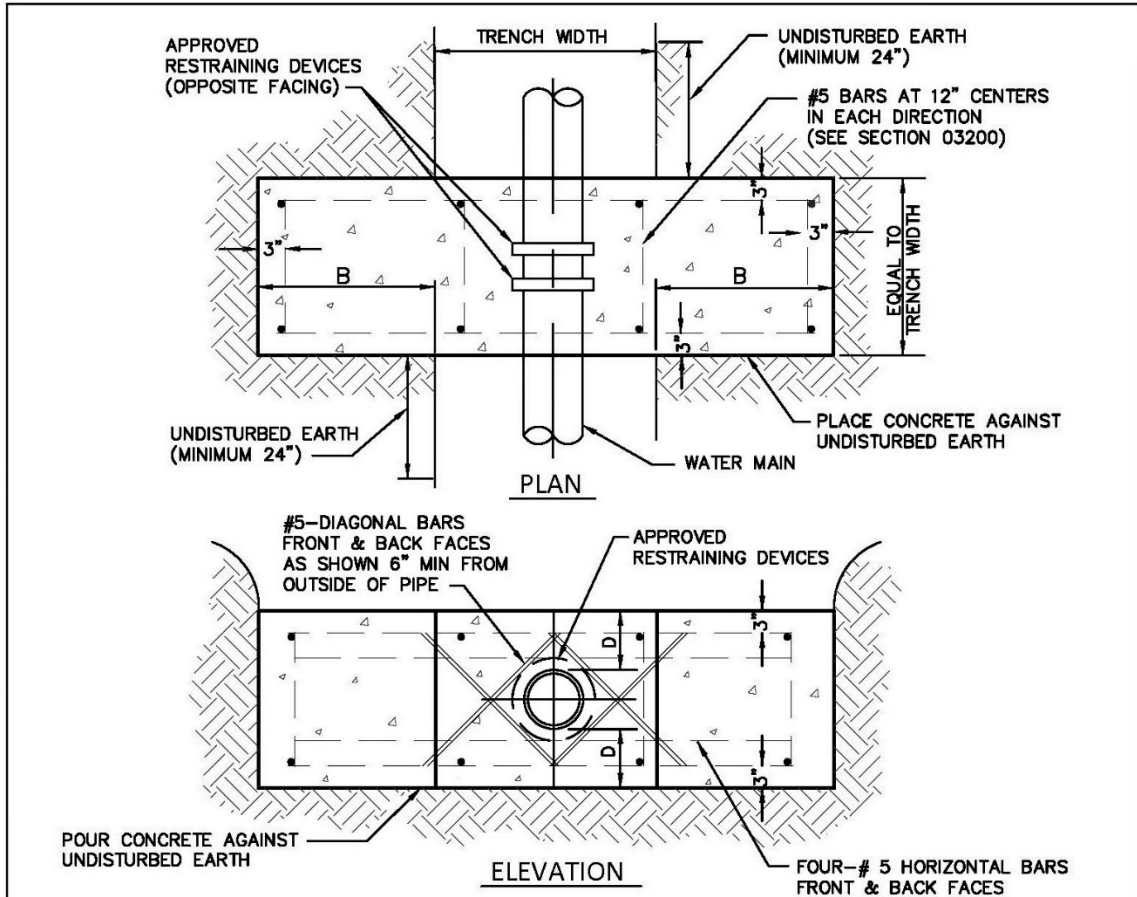

NOTES:

1. STRADDLE BLOCKS 12" ARE SIZED FOR 175 P.S.I. , AND 16" & LARGER ARE SIZED FOR 150 P.S.I. LINE PRESSURE 50% SURGE.
2. THE PROJECT DESIGN PROFESSIONAL IS RESPONSIBLE FOR DESIGN OF STRADDLE BLOCKS.
3. THE SIZES SPECIFIED HEREIN ARE MINIMUM SIZES BASED ON SOIL RESISTANCE OF 2,500 POUNDS PER SQUARE FOOT. WHERE SOFTER SOILS MAY BE ENCOUNTERED, THE PROJECT DESIGN PROFESSIONAL MUST PROVIDE A DESIGN FOR REVIEW BY THE DEPARTMENT.

PIPE SIZE	TRENCH WIDTH (in.)	B (in.)	D (in.)	REQUIRED BEARING AREA (SQ. FT.)	ESTIMATED CONCRETE REQ. CYD.
12"	34	38	17	23.8	3.60
16"	40	45	22	36.2	6.51

THIS DETAIL TO BE USED ONLY IF SPECIFIED BY PROJECT DESIGN PROFESSIONAL ON APPROVED FOR CONSTRUCTION DRAWINGS.

**ALT. STRADDLE BLOCK FOR 12 & 16 INCH PIPE**  
**2,500 POUNDS PER SQUARE FOOT SOIL RESISTANCE**

WATER SERVICES  
 CITY OF KANSAS CITY, MISSOURI  
 DRAWING NO. **02669-9**

DEVELOPED BY: \_\_\_\_\_ APPROVED BY: \_\_\_\_\_  
 TECHNICAL ADVISORY COMMITTEE DATE: 1/14/2021

DETAIL 02669-10

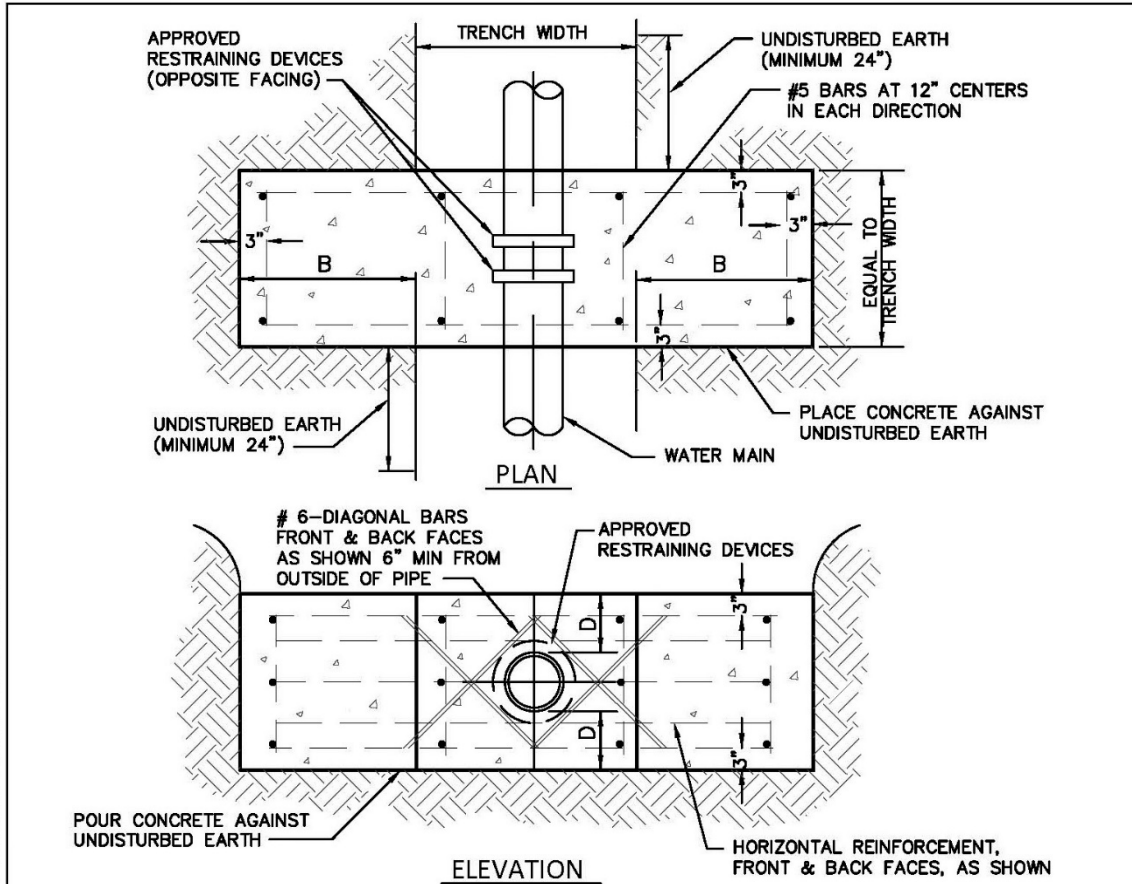

NOTES:

1. STRADDLE BLOCKS ARE SIZED FOR 150 P.S.I. LINE PRESSURE 50% SURGE.
2. THE PROJECT DESIGN PROFESSIONAL IS RESPONSIBLE FOR DESIGN OF STRADDLE BLOCKS. THE SIZES SPECIFIED HEREIN ARE MINIMUM SIZES BASED ON SOIL RESISTANCE OF 2,500 POUNDS PER SQUARE FOOT. WHERE SOFTER SOILS MAY BE ENCOUNTERED, THE PROJECT DESIGN PROFESSIONAL MUST PROVIDE A DESIGN FOR REVIEW BY THE DEPARTMENT.

PIPE SIZE	BAR SIZE	NO. OF BARS	TRENCH WIDTH (in.)	B (in.)	D (in.)	REQUIRED BEARING AREA (SQ. FT.)	ESTIMATED CONCRETE REQ. CYD.
20"	#5	5	44	60	24	56.5	10.2
24"	#6	5	48	78	26	81.4	15.5
30"	#7	5	60	96	33	127.2	30.2

THIS DETAIL TO BE USED ONLY IF SPECIFIED BY PROJECT DESIGN PROFESSIONAL ON APPROVED FOR CONSTRUCTION DRAWINGS.

ALT. STRADDLE BLOCK FOR 20, 24, & 30 INCH PIPE  
2,500 POUNDS PER SQUARE FOOT SOIL RESISTANCE

WATER SERVICES  
CITY OF KANSAS CITY, MISSOURI

DRAWING NO. 02669-10

DEVELOPED BY:  
TECHNICAL ADVISORY COMMITTEE

APPROVED BY:  
DATE: 1/14/2021

1 OF 1

DETAIL 02669-11

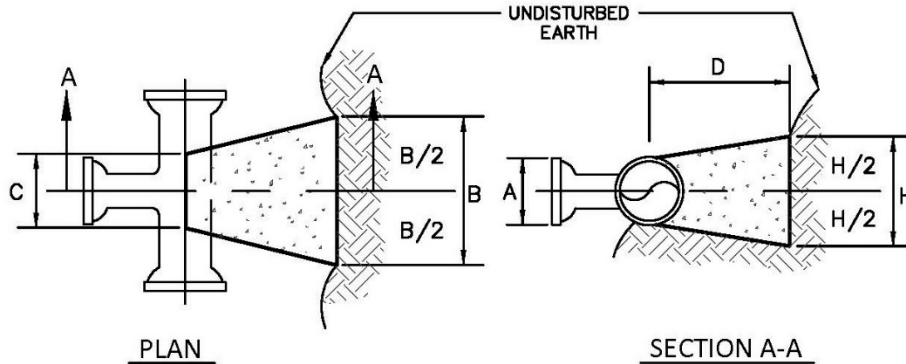

NOTES:

1. BACKING BLOCKS FOR PIPING SIZES UP THROUGH 12-INCH ARE BASED ON WORKING PRESSURE OF 175 P.S.I. PLUS 50% SURGE.
2. BACKING BLOCKS FOR PIPING SIZES 16-INCH THROUGH 24-INCH ARE BASED ON A WORKING PRESSURE OF 150 P.S.I. PLUS 50% SURGE.
3. THE PROJECT DESIGN PROFESSIONAL IS RESPONSIBLE FOR THE DESIGN OF THRUST BLOCKS. THE BLOCK SIZES SPECIFIED HEREIN ARE MINIMUM SIZES, BASED ON SOIL RESISTANCE OF 3,000 POUNDS PER SQUARE FOOT. WHERE SOFTER SOILS MAY BE ENCOUNTERED, THE PROJECT DESIGN PROFESSIONAL MUST PROVIDE A DESIGN FOR REVIEW BY THE DEPARTMENT.

BRANCH OR PLUG SIZE A	B (in.)	C (in.)	D (in.)	H (in.)	REQUIRED BEARING AREA (SQ.FT.)	ESTIMATED CONCRETE REQ. CYD.
6"	40	6	17	18	4.9	0.14
8"	54	8	23	24	8.8	0.34
12"	72	12	30	40	19.8	0.97
16"	88	16	36	50	30.2	1.80
20"	114	20	47	60	47.1	3.65
24"	136	24	56	72	67.9	6.22
30"	154	30	62	100	106.0	10.83

THIS DETAIL TO BE USED ONLY IF SPECIFIED BY PROJECT DESIGN PROFESSIONAL ON APPROVED FOR CONSTRUCTION DRAWINGS.

**ALT. BACKING BLOCKS FOR TEES AND PLUGS**  
**3,000 POUNDS PER SQUARE FOOT SOIL RESISTANCE**

WATER SERVICES  
 CITY OF KANSAS CITY, MISSOURI

DRAWING NO. **02669-11**

DEVELOPED BY: \_\_\_\_\_  
 TECHNICAL ADVISORY COMMITTEE

APPROVED BY: \_\_\_\_\_  
 DATE: 1/13/2021

1 OF 1

DETAIL 02669-12

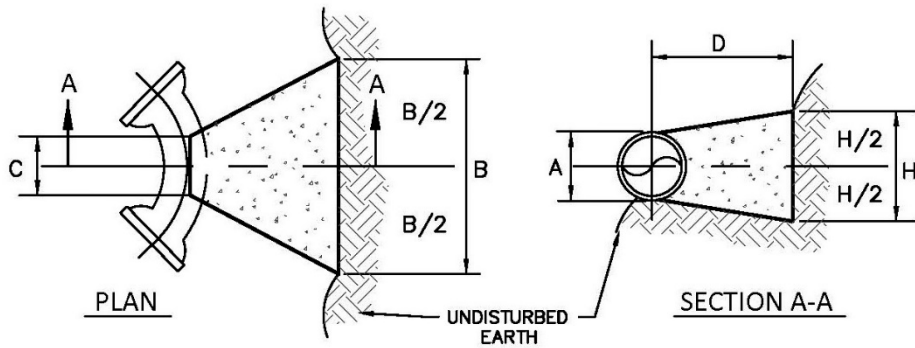

NOTES:

1. BACKING BLOCKS FOR PIPING SIZES UP THROUGH 12-INCH ARE BASED ON WORKING PRESSURE OF 175 P.S.I. PLUS 50% SURGE.
2. BACKING BLOCKS FOR PIPING SIZES 16-INCH THROUGH 24-INCH ARE BASED ON A WORKING PRESSURE OF 150 P.S.I. PLUS 50% SURGE.
3. THE PROJECT DESIGN PROFESSIONAL IS RESPONSIBLE FOR THE DESIGN OF THRUST BLOCKS. THE BLOCK SIZES SPECIFIED HEREIN ARE MINIMUM SIZES, BASED ON SOIL RESISTANCE OF 3,000 POUNDS PER SQUARE FOOT. WHERE SOFTER SOILS MAY BE ENCOUNTERED, THE PROJECT DESIGN PROFESSIONAL MUST PROVIDE A DESIGN FOR REVIEW BY THE DEPARTMENT.

11° DEGREE BENDS						
PIPE SIZE A	B (in.)	C (in.)	D (in.)	H (in.)	REQUIRED BEARING AREA (SQ.FT.)	ESTIMATED CONCRETE REQ. CYD.
6"	18	6	12	12	1.0	0.032
8"	20	8	12	14	1.7	0.044
12"	32	12	12	20	3.9	0.101
16"	36	16	12	24	5.9	0.144
20"	40	20	12	34	9.2	0.226
24"	52	24	14	38	13.3	0.380
30"	76	30	23	40	20.8	0.971

22° DEGREE BENDS						
PIPE SIZE A	B (in.)	C (in.)	D (in.)	H (in.)	REQUIRED BEARING AREA (SQ.FT.)	ESTIMATED CONCRETE REQ. CYD.
6"	24	6	12	14	1.9	0.048
8"	28	8	12	18	3.4	0.073
12"	46	12	17	24	7.7	0.227
16"	62	16	23	28	11.8	0.491
20"	78	20	29	34	18.4	0.949
24"	96	24	36	40	26.5	1.704
30"	142	30	56	42	41.4	4.100

45° DEGREE BENDS						
PIPE SIZE A	B (in.)	C (in.)	D (in.)	H (in.)	REQUIRED BEARING AREA (SQ.FT.)	ESTIMATED CONCRETE REQ. CYD.
6"	30	6	12	18	3.8	0.074
8"	40	8	16	24	6.7	0.176
12"	74	12	31	30	15.1	0.785
16"	94	16	39	36	23.1	1.521
20"	120	20	50	44	36.1	3.044
24"	140	24	58	54	51.9	5.057
30"	164	30	67	72	81.2	9.125

90° DEGREE BENDS						
PIPE SIZE A	B (in.)	C (in.)	D (in.)	H (in.)	REQUIRED BEARING AREA (SQ.FT.)	ESTIMATED CONCRETE REQ. CYD.
6"	52	6	23	20	7.0	0.265
8"	72	8	32	26	12.4	0.664
12"	112	12	50	36	28.0	2.238
16"	128	16	56	48	42.7	3.841
20"	166	20	73	58	66.6	7.845
24"	188	24	82	74	96.0	12.732
30"	270	30	120	80	149.9	28.935

THIS DETAIL TO BE USED ONLY IF SPECIFIED BY PROJECT DESIGN PROFESSIONAL ON APPROVED FOR CONSTRUCTION DRAWINGS.

**ALT. BACKING BLOCKS FOR HORIZONTAL BENDS  
3,000 POUNDS PER SQUARE FOOT SOIL RESISTANCE**

WATER SERVICES  
CITY OF KANSAS CITY, MISSOURI

DRAWING NO. **02669-12**

DEVELOPED BY: \_\_\_\_\_  
TECHNICAL ADVISORY COMMITTEE

APPROVED BY: \_\_\_\_\_

DATE: 1/13/2021

1 OF 1



DETAIL 02669-13

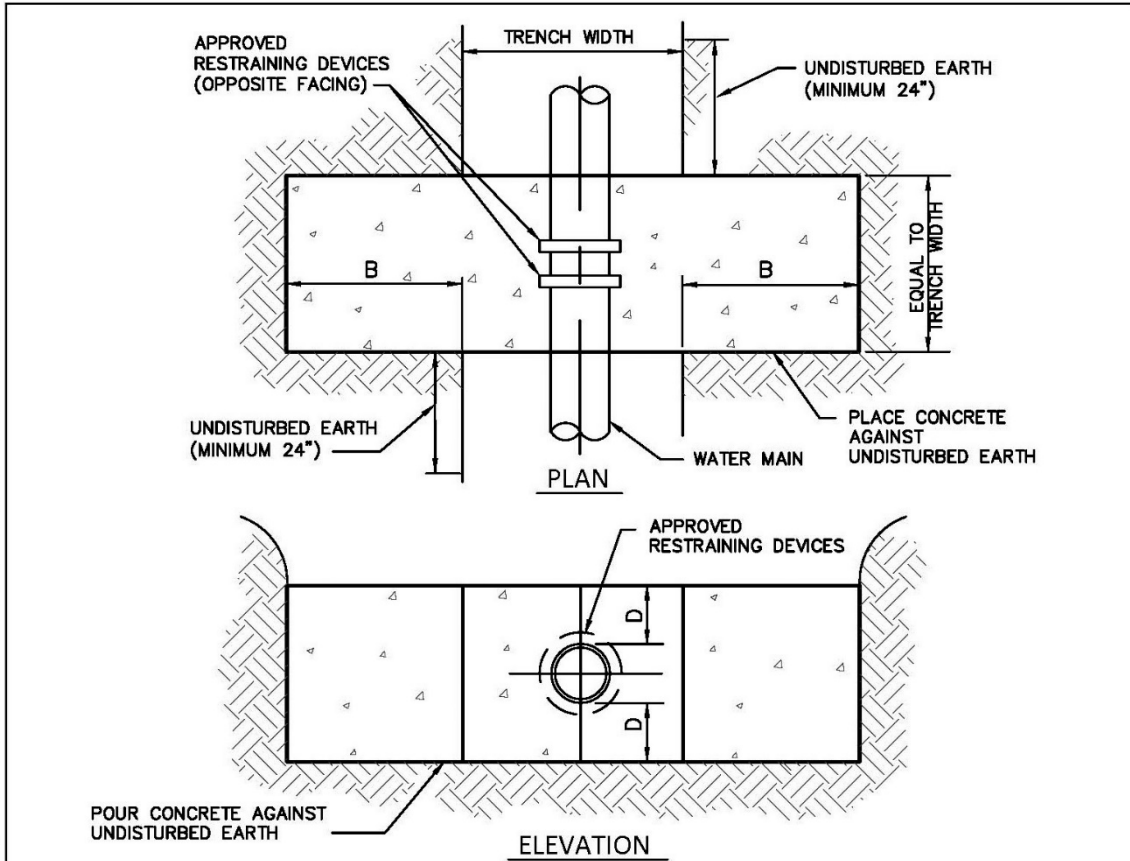

NOTES:

1. STRADDLE BLOCKS ARE SIZED FOR 175 P.S.I. LINE PRESSURE 50% SURGE.
2. THE PROJECT DESIGN PROFESSIONAL IS RESPONSIBLE FOR DESIGN OF STRADDLE BLOCKS. THE SIZES SPECIFIED HEREIN ARE MINIMUM SIZES BASED ON SOIL RESISTANCE OF 3,000 POUNDS PER SQUARE FOOT. WHERE SOFTER SOILS MAY BE ENCOUNTERED, THE PROJECT DESIGN PROFESSIONAL MUST PROVIDE A DESIGN FOR REVIEW BY THE DEPARTMENT.

PIPE SIZE	TRENCH WIDTH (in.)	B (in.)	D (in.)	REQUIRED BEARING AREA (SQ. FT.)	ESTIMATED CONCRETE REQ. CYD.
6"	30	24	5	4.9	0.62
8"	32	29	7	8.8	1.00

THIS DETAIL TO BE USED ONLY IF SPECIFIED BY PROJECT DESIGN PROFESSIONAL ON APPROVED FOR CONSTRUCTION DRAWINGS.

**ALT. STRADDLE BLOCK FOR 6 AND 8 INCH PIPE**  
**3,000 POUNDS PER SQUARE FOOT SOIL RESISTANCE**

WATER SERVICES  
 CITY OF KANSAS CITY, MISSOURI  
 DRAWING NO. **02669-13**

DEVELOPED BY: \_\_\_\_\_ APPROVED BY: \_\_\_\_\_  
 TECHNICAL ADVISORY COMMITTEE DATE: 1/14/2021

1  
OF  
1

DETAIL 02669-14

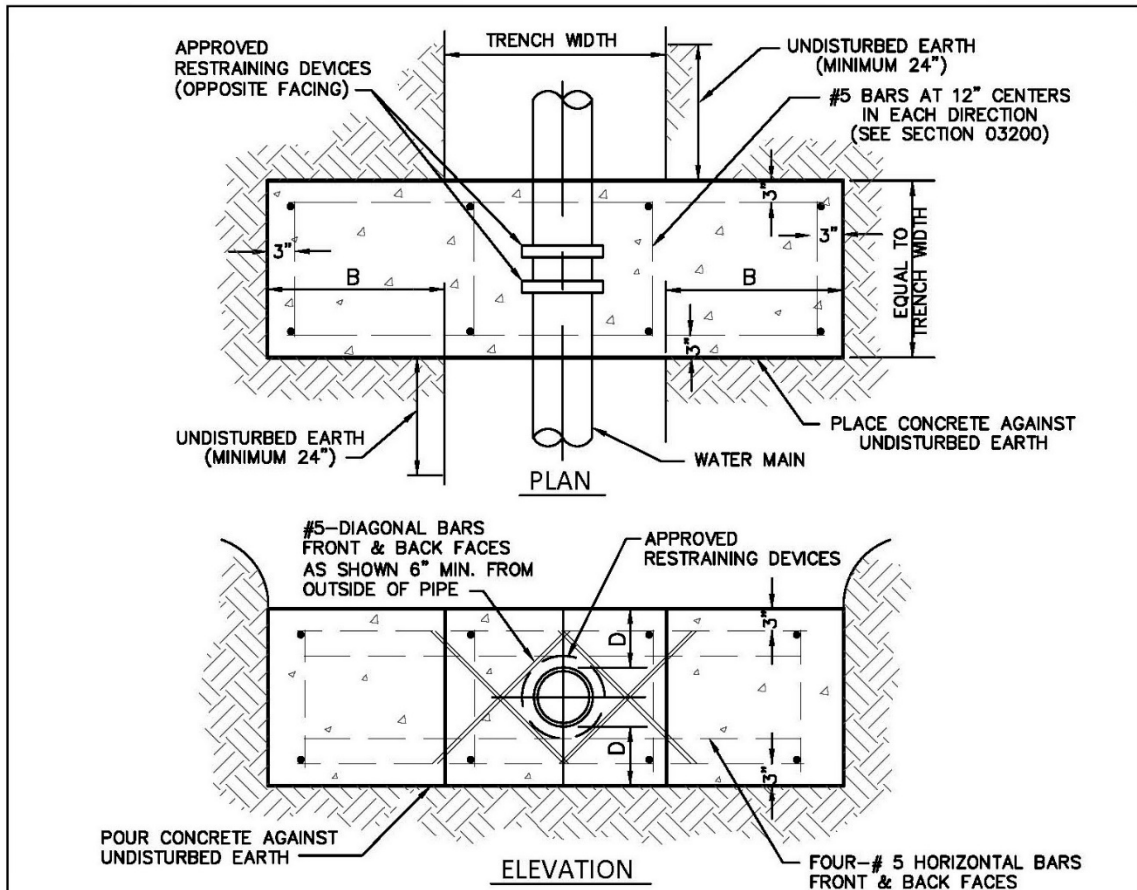

NOTES:

1. STRADDLE BLOCKS 12" ARE SIZED FOR 175 P.S.I. , AND 16" & LARGER ARE SIZED FOR 150 P.S.I. LINE PRESSURE 50% SURGE.
2. THE PROJECT DESIGN PROFESSIONAL IS RESPONSIBLE FOR DESIGN OF STRADDLE BLOCKS. THE SIZES SPECIFIED HEREIN ARE MINIMUM SIZES BASED ON SOIL RESISTANCE OF 3,000 POUNDS PER SQUARE FOOT. WHERE SOFTER SOILS MAY BE ENCOUNTERED, THE PROJECT DESIGN PROFESSIONAL MUST PROVIDE A DESIGN FOR REVIEW BY THE DEPARTMENT.

PIPE SIZE	TRENCH WIDTH (in.)	B (in.)	D (in.)	REQUIRED BEARING AREA (SQ. FT.)	ESTIMATED CONCRETE REQ. CYD.
12"	34	34	15	19.8	3.0
16"	40	42	18	30.2	5.4

THIS DETAIL TO BE USED ONLY IF SPECIFIED BY PROJECT DESIGN PROFESSIONAL ON APPROVED FOR CONSTRUCTION DRAWINGS.

**ALT. STRADDLE BLOCK FOR 12 & 16 INCH PIPE**  
**3,000 POUNDS PER SQUARE FOOT SOIL RESISTANCE**

WATER SERVICES  
 CITY OF KANSAS CITY, MISSOURI  
 DRAWING NO. **02669-14**

DEVELOPED BY: \_\_\_\_\_ APPROVED BY: \_\_\_\_\_  
 TECHNICAL ADVISORY COMMITTEE DATE: 1/14/2021

1 OF 1

DETAIL 02669-15

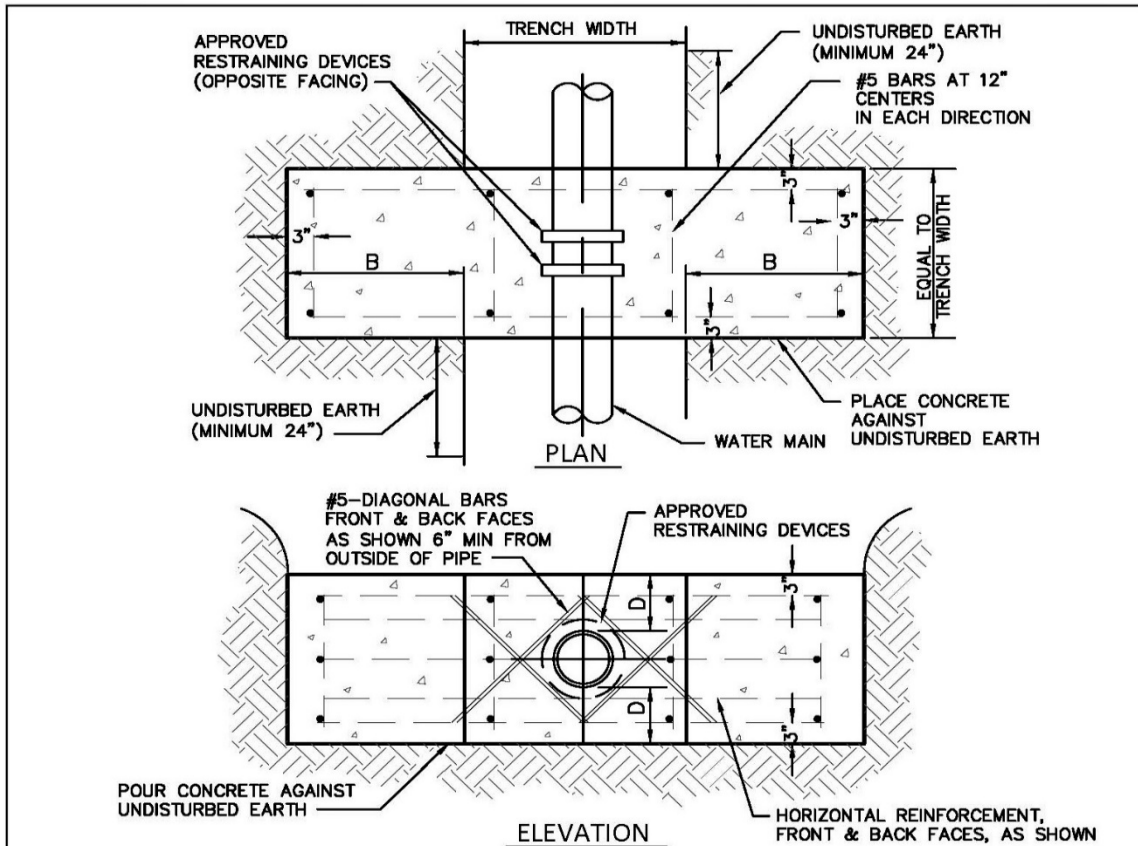

NOTES:

1. STRADDLE BLOCKS ARE SIZED FOR 150 P.S.I. LINE PRESSURE 50% SURGE.
2. THE PROJECT DESIGN PROFESSIONAL IS RESPONSIBLE FOR DESIGN OF STRADDLE BLOCKS. THE SIZES SPECIFIED HEREIN ARE MINIMUM SIZES BASED ON SOIL RESISTANCE OF 3,000 POUNDS PER SQUARE FOOT. WHERE SOFTER SOILS MAY BE ENCOUNTERED, THE PROJECT DESIGN PROFESSIONAL MUST PROVIDE A DESIGN FOR REVIEW BY THE DEPARTMENT.

PIPE SIZE	BAR SIZE	NO. OF BARS	TRENCH WIDTH (in.)	B (in.)	D (in.)	REQUIRED BEARING AREA (SQ. FT.)	ESTIMATED CONCRETE REQ. CYD.
20"	#5	5	44	57	20	47.1	8.6
24"	#6	5	48	68	24	68.0	13.2
30"	#7	5	60	85	30	106.3	25.7

THIS DETAIL TO BE USED ONLY IF SPECIFIED BY PROJECT DESIGN PROFESSIONAL ON APPROVED FOR CONSTRUCTION DRAWINGS.

ALT. STRADDLE BLOCK FOR 20, 24, & 30 INCH PIPE  
3,000 POUNDS PER SQUARE FOOT SOIL RESISTANCE

WATER SERVICES  
CITY OF KANSAS CITY, MISSOURI

DRAWING NO. 02669-15

DEVELOPED BY: \_\_\_\_\_  
TECHNICAL ADVISORY COMMITTEE

APPROVED BY: \_\_\_\_\_

DATE: 1/14/2021

1 OF 1

END OF SECTION

## SECTION 03000 - MISCELLANEOUS CONCRETE

### PART 1 - GENERAL

#### 1.1 SCOPE

- A. The Contractor shall perform all concrete work as required to complete the work specified in the contract documents.
- B. This section covers miscellaneous concrete work associated with the construction of water, wastewater and stormwater infrastructure. This section does not apply to concrete work associated with surface restoration. See Section 02575 – Surface Restoration for concrete requirements associated with curb, gutter, sidewalk and street work.

#### 1.2 RELATED SECTIONS

- A. Section 03370 – Sanitary Sewer Manhole Construction.
- B. Section 03608 – Concrete Vaults.

#### 1.3 CODES AND STANDARDS

- A. The publications listed below form a part of this specification to the extent referenced. The publications are referred to within the text by the basic designation only.
- B. American Society for Testing and Materials (ASTM):
  - ASTM A615 Deformed and Plain Billet Steel Bars for Concrete Reinforcement.
  - ASTM C31 Test Methods of Making and Curing Concrete Test Specimens in the Field.
  - ASTM C33 Concrete Aggregates.
  - ASTM C39 Test Method for Compressive Strength of Cylindrical Concrete Specimens.
  - ASTM C94 Ready-Mixed Concrete.
  - ASTM C143 Standard Test Method for Slump of Hydraulic-Cement Concrete.
  - ASTM C150 Portland Cement.
- C. American Concrete Institute (ACI):
  - ACI 304 Recommended Practice for Measuring, Mixing, Transporting and Placing Concrete.
  - ACI 305 Committee Report on Hot-Weather Concreting.
  - ACI 306 Committee Report on Cold-Weather Concreting.
  - ACI 309 Recommended Practice for Consolidation of Concrete.
  - ACI 318 Building Code Requirements for Reinforced Concrete.
  - ACI 347 Recommended Practice for Concrete Formwork.

#### 1.4 SUBMITTALS

- A. Contractor shall submit product data for review on the following items required by this Division:
  - 1. Laboratory name.
  - 2. Aggregate testing and gradation.
  - 3. Design mix.
- B. Product data shall be submitted in accordance with Section 01300 – Submittals.

## PART 2 - PRODUCTS

### 2.1 CEMENT

A. Cement shall conform to ASTM C150, Type I, unless high early strength is required in which instance Type III shall be used. Cement may be bagged or bulk.

### 2.2 FINE AGGREGATE

A. Fine aggregate, clean natural sand, shall conform to ASTM C33 and have the following gradation:

<u>Sieve</u>	<u>% Passing</u>	<u>% Retained</u>
3/8"	100	0
#4	95-100	0-5
#8	80-100	0-20
#16	50-85	15-50
#30	25-60	40-75
#50	10-30	70-90
#100	2-10	90-98

### 2.3 COARSE AGGREGATE

A. Clean crushed rock, washed gravel, or other inert granular material, except that clay and shale particles shall not exceed one percent. Coarse aggregate shall conform to ASTM C33 and have the following gradation:

<u>Sq. Sieve</u>	<u>% Passing</u>	<u>% Retained</u>
3/4"	90-100	0-10
3/8"	20-55	45-80
#4	0-10	90-100
#8	0-5	95-100

### 2.4 WATER

A. Potable water from a municipal or other public water supply district shall be used for mixing and curing.

### 2.5 REINFORCING STEEL

A. Reinforcing Steel:

1. Reinforcing steel bars shall conform to the requirements of the following Standards and Grades:
  - (a) ASTM A615: Grade 40 or 60.
  - (b) ASTM A616: Grade 50 or 60.

B. Bending details shall conform to ACI 318.

### 2.6 FORMS AND FORMWORK ACCESSORIES

A. Forms:

1. Suitable and substantial forms shall be provided. All forms shall be constructed and maintained plumb and true to line, securely braced, tied, clamped and shored in order to prevent leakage of concrete and prevent deflection or displacement of forms during

placement of concrete. All exposed corners and edges shall have 1" fillets. All joints shall be mortar tight; open joints shall be sealed as required.

2. Where applicable, undisturbed earth may be used in lieu of forms.
  3. The deflection of the forms due to the weight and rate of placing concrete, placing equipment, and workmen shall be accurately figured and taken into account in the design of the forms so that finished concrete members will have surfaces, lines, planes, and elevations required within tolerances in accordance with ACI 117.
  4. All forms shall be removed prior to backfill unless the following conditions are met:
    - (a) As directed by the City.
    - (b) When constructed of unbraced plywood having a thickness of ½-inch or less, removal shall be optional unless otherwise directed by the City.
  5. Forms shall be constructed so that they can be removed without damage to the concrete.
- B. Formwork accessories:
1. Forms shall be securely braced and tied with approved form ties that do not leave any parts within ¾ inch of the surface of the concrete. Wire ties and wood spreaders will not be permitted.

## 2.7 CONCRETE MIX

### A. Concrete:

1. Concrete shall conform to KCMO PW 2208 except as follows:
  - (a) Limestone may be used as coarse aggregate.
  - (b) Design strength of concrete shall be 4,500 psi or greater at 28 days.
  - (c) Maximum slump shall be 4 inches. Determination of slump shall conform to ASTM C143.
  - (d) Coarse Aggregate: 1-inch maximum.
  - (e) Air entrainment admixture is required to provide 4 to 6 percent entrained air when placed, in conformance with ASTM C185.
  - (f) Water reducing admixture is required.
2. Ready mix concrete shall be supplied by a plant approved by the KCMO Public Works Department according to the Ready Mix Concrete Quality Management Plan. Submit ready mix concrete plant information in accordance with paragraph SUBMITTALS.
3. Submit concrete mix design in accordance with KCMO PW 2208.C and in accordance with the paragraph SUBMITTALS.

### B. Concrete shall be delivered to the site in conformance with ASTM C94.

## PART 3 - EXECUTION

### 3.1 REINFORCING STEEL AND CONCRETE

#### A. Placing of Reinforcing Steel:

1. Before being installed in the final position, all metal reinforcements shall be free of mud, clay, ice, grease, oil, loose rust and scale, and other coatings that would reduce or destroy the bond.
2. Metal reinforcements shall be accurately formed and positioned to the required dimensions. All bars are to be accurately placed and securely tied at all intersections. All reinforcing steel shall be placed so it is covered with a minimum of 3" of concrete.
3. Steel reinforcements shall be accurately positioned as required and shall be secured against displacement by using annealed wire ties or suitable clips at all intersections.
4. The steel reinforcements shall be supported by metal supports, spacers, or hangers.
5. The legs on the metal chair supports shall be plastic coated.

B. Forms:

1. Verify lines, levels and centers before proceeding with formwork.
2. A coat of non-staining oil, lacquer, or other approved material shall be applied to protect form surface and to facilitate stripping. Coating shall be applied in strict accordance with the directions of the manufacturer.
3. Forms shall be removed in such manner as to assure the complete safety of the structure. In no case shall supporting forms or shoring be removed until the concrete has acquired sufficient strength.

C. Placing of Concrete:

1. Only those methods and arrangements of equipment shall be used which will reduce to a minimum any segregation of coarse aggregate from the concrete.
2. Every consideration shall be given to the proper placement of all concrete and the proper care of all concrete after placement.
3. Concrete shall be deposited into the forms or on the grade as nearly as practicable in its final position and in such manner that the concrete will completely fill the forms.
4. Vibration shall not be used to move concrete in a horizontal direction after initial placement.
5. Concrete that has partially hardened or has been contaminated by foreign material shall not be deposited in the Work and shall be removed from the Site at no additional cost to the City.
6. When inclined chutes beyond the mixer are permitted by the City, a baffle shall be provided at the bottom end so that concrete will drop vertically without segregation.
7. No water shall be added to the concrete for any reason at the job site that will result in exceeding the specified water-cement ratio. Any water withheld when batching the concrete shall be noted on the material delivery ticket.
8. Care shall be taken to assure proper concrete coverage of reinforcing steel as designed.
9. Placement operations shall be performed in such a manner as to prevent loose earth falling into the excavation during placement of concrete.
10. Concrete that might contact forms or reinforcing steel during placement shall be placed by the use of trunks or pipes whenever the drop exceeds six (6) feet for unexposed work, or three (3) feet for exposed work.
11. When trunks or pipe are used, they shall be located at horizontal spacing of not to exceed ten (10) feet.
12. Concrete for thrust restraints shall be placed in horizontal layers not exceeding two (2) feet in depth.
13. Placing of concrete in thrust restraints shall be done in such manner as to prevent "cold joints," both horizontally and vertically.

D. Vibrating:

1. In conformance with ACI 309, mechanical internal vibrators shall be used whenever possible in all formed concrete work.
2. Vibrators shall be inserted at uniform spacing of twelve (12) inches to twenty (20) inches to assure thorough consolidation of all concrete.
3. Vibrators shall be inserted and withdrawn vertically to a depth, which will assure penetration into the previous lift with vibration periods of from five (5) to fifteen (15) seconds.
4. Form vibration and/or hand spading will be required at points inaccessible for thorough internal vibration.
5. During placement of concrete, stand-by vibrators shall be immediately available in the event of mechanical failure in the vibrators being used.

- E. No concrete shall be deposited below water. The excavation may be damp but shall contain no water.
- F. Concrete shall be conveyed from the mixer to the place of final deposit by methods which will prevent the separation or loss of materials. Retempering of concrete is not permissible.
- G. For formed surfaces, the Contractor shall break off ties, grout voids which are deeper than ½" and chip out honeycombed areas to solid concrete and grout flush with formed surface.
- H. Curing shall be maintained continuously for seven days after placing concrete or until forms are removed and the surface finished. Concrete surface temperature is to be maintained between 50°F and 100°F for at least seven days.
- I. Concrete shall not be placed on iced or frozen subgrade or when the air temperature is below 20°F. Concreting shall not be continued when the air temperature is below 45°F unless the following conditions are attained:
  - 1. Mixing water shall be heated (to a maximum of 150°F).
  - 2. Aggregates shall be heated until free of all ice and frost.
  - 3. The concrete temperature after mixing shall be between 50°F and 70°F if the air temperature is 20°F to 45°F.
  - 4. After the concrete is placed, it shall be covered, protected, and heated so as to maintain a minimum of 70°F air temperature for the 24 hours and 50°F air temperature for the next six days. Open-flame type heaters are not permitted. Heating equipment not vented outside of the covering will not be permitted.
  - 5. Moist conditions shall be maintained during the heating period.
  - 6. All covering, heating equipment, etc., shall be on hand and approved by the Engineer before any concrete is placed.
- J. Calcium chloride, as an admixture, shall not be used.
- K. Exposed concrete is not to be placed in air temperatures above 100°F. Cover, protect and cool work as to maintain the temperature of the concrete below 100°F. The concrete temperature, after mixing, shall not be greater than 85°F. Spray and/or shade aggregate piles and cool mixing water as required.

### 3.2 CONCRETE TEST CYLINDERS

- A. All concrete test cylinders shall be provided by a certified testing laboratory. The testing of test cylinders, including transportation, shall be paid for by the Contractor.
- B. The laboratory shall make at least three test cylinders for each day's pour in excess of 10 cubic yards of each class of concrete, and three test cylinders for each additional 50 cubic yards or major fraction thereof, as directed by the Engineer.
- C. The laboratory shall ship the test cylinders to the laboratory on the second day, where the laboratory shall proceed to cure until tested. One cylinder shall be tested on the seventh day, and the remaining cylinders shall be tested on the 28th day. The test cylinders shall be identified at the time cast, and as to which pour is represented. Unsatisfactory tests of cylinders shall make the concrete represented subject to rejection, with consequent removal and replacement required.
- D. Concrete test cylinders shall be cast and tested in accordance with ASTM C31 and C39. The testing laboratory shall furnish four copies of test reports for test cylinders and distributed as follows:
  - 1. 2 copies – City.
  - 2. 2 copies – Contractor.



3.3 CLEANUP

- A. Cleanup operations shall be conducted in accordance with Section 01566 –  
Cleanup Operations

END OF SECTION