



CITY PLAN COMMISSION STAFF REPORT

City of Kansas City, Missouri
City Planning & Development Department
www.kcmo.gov/cpc

November 6, 2024

Project Name

Popeyes at BB North Oak

Docket # 13

Request

CD-CPC-2024-00149
Rezoning to UR/MPD (Major Amendment)

Applicant

Daniel Finn
Phelps Engineering

Owner

Jeff Berg
BB North Oak Devco LLC

Location	9806 N Oak Trfy
Area	About 7.2 Acres
Zoning	MPD
Council District	1 st
County	Clay
School District	North Kansas City

Surrounding Land Uses

North: Undeveloped, institutional uses, zoned R-1.5, R-80
South: Commercial uses, zoned MPD, B3-2
East: Residential uses, zoned R-7.5
West: Residential uses, zoned MPD, R-1.5

Land Use Plan

The Gashland/Nashua Area Plan recommends Residential Medium Density and Mixed Use Neighborhood future land use for this location. See Criteria A for more information.

Major Street Plan

North Oak Trafficway is identified on the City's Major Street Plan as a Local Link.

APPROVAL PROCESS



SUMMARY OF REQUEST + KEY POINTS

The applicant is seeking approval of a major amendment to a Master Planned Development to allow for a drive-through restaurant in district MPD on about 7.20 acres generally located at 9806 N Oak Trafficway.

PROJECT TIMELINE

The application for the subject request was filed on 10/1/2024. Scheduling deviations from 2024 Cycle 11.1 have occurred.

- The applicant requested a continuance from the November 6th CPC hearing for additional time to complete public engagement.

NEIGHBORHOOD AND CIVIC ORGANIZATIONS NOTIFIED

The subject site is not located within a registered neighborhood or homes association.

REQUIRED PUBLIC ENGAGEMENT

Public engagement as required by 88-505-12 does apply to this request. Applicant hosted a meeting on 11/13/2024. A summary of the meeting is attached to the staff report, see Attachment #3.

EXISTING CONDITIONS

The subject site is currently undeveloped and part Lot 4 out of five commercial pad sites in the MPD.

CONTROLLING + RELATED CASES

Case No. CD-CPC-2021-00208 – Ordinance 220235 9700 N Oak - A request to approve a major amendment to the approved MPD (Master Planned Development District) preliminary development plan, which also serves as preliminary plat to create five (5) lots and one (1) tract on about 7.2 acres, generally located at the northwest corner of N. Oak Trfy and NE. 97th St.
Approved March 28, 2022

Case No. CD-CPC-2023-00131 – Ordinance 240510 - approval of a major amendment to a previously approved Master Planned Development to allow for an oversized menu board monument sign in district MPD on about 1.4 acres generally located at the northwest corner of NE 97th Street and N Oak Trafficway.
Approved 6/27/2024

PROFESSIONAL STAFF RECOMMENDATION

Docket #13 Approval with Conditions

VICINITY MAP



PLAN REVIEW

The plan proposes amending Lot 4 from auto repair, limited (oil change) to a drive-through eating and drinking establishment. Popeye's is the proposed tenant for Lot 4, whereas the previously approved plan showed a drive-through restaurant for Popeye's on Lot 5. The proposed building is 2,700 square feet with two drive-through lanes fronting N Oak Trafficway.

There is one proposed access to Lot 4 from the private drive to the west. Vehicles will circulate counterclockwise on the site through the parking area and drive-through. Twenty-seven parking spaces are provided on Lot 4 and there are no proposed changes to the other lots within the plan area.

Landscaping is shown between the drive-through and North Oak Trafficway and the private drive to the north. A stormwater detention basin is proposed between the drive-through and N Oak Trafficway and will be planted with sod. Proposed species on the landscape plan include Red Maple, Honey Locust, White Oak, Dogwood, inkberry, Sumac, Switch Grass, and others.

Proposed building materials include wood siding, brick, and EIFS.

PLAN ANALYSIS

MPD Lot and Building (88-280), Use- Specific (88-300), and Development Standards (88-400)

Standards	Applicability	Meets	More Information
Lot and Building Standards (88-280)	Yes	Yes	
Accessory or Use- Specific Standards (88-340)	Yes	Yes	Drive-Through Standards
Boulevard and Parkway Standards (88-323)	No	N/A	
Parkland Dedication (88-408)	No	N/A	
Tree Preservation and Protection (88-424)	No	N/A	
Parking and Loading Standards (88-420)	Yes	Yes	
Landscape and Screening Standards (88-425)	Yes	Yes, subject to conditions	
Outdoor Lighting Standards (88-430)	Yes	Yes, subject to conditions	
Sign Standards (88-445)	Yes	Yes, subject to conditions	
Pedestrian Standards (88-450)	Yes	Yes	

SPECIFIC REVIEW CRITERIA

Development Plans, Project Plan, or Site Plan (88-516-05)

In order to be approved, a development plan, project plan, or site plan must comply with all of the following criteria:

A. The plan must comply with all standards of the Zoning and Development Code and all other applicable city ordinances and policies;

The proposed plan complies with applicable sections of the Zoning and Development Code. Although the plan complies with Code, staff does not feel three drive-through restaurants and one drive-through carwash are the highest and best uses across the street from a residential neighborhood and next to multi-unit residential buildings.

The previously approved plan did not comply with the Medium Density Residential future land use designation in the Gashland/Nashua Area Plan, but no Area Plan amendment was required by Long Range Planning staff. No Area plan amendment was required by Long Range staff for this major amendment as only one lot is changing.

Long Range Planning determined "the development plan is likely to achieve both Gashland/Nashua area plan and KC Spirit Playbook goals. Since the first submittal the developer has implemented the

Long Range correction to include sidewalks on the western side of the property and a direct sidewalk connection to the main structure. To better align with the Gashland/Nashua Area Plan and the KC Spirit Playbook, it is recommended that additional landscaping be incorporated along North Oak Trafficway, as this street is designated as a primary image street within the area plan." -Alexis Berra

B. The proposed use must be allowed in the district in which it is located;

The MPD zoning establishes allowed uses. The previously approved MPD allowed motor vehicle repair, limited on Lot 4 and the proposed change is to a drive-through eating and drinking establishment. There is one drive-through restaurant already constructed on Lot 1 and another shown on the plan for Lot 5.

C. Vehicular ingress and egress to and from the site, and circulation within the site must provide for safe, efficient, and convenient movement of traffic not only within the site but on adjacent roadways;

Vehicular access to the site is adequate from the private drive to the west of the lot. All lots will be accessed from this private drive rather than curb cuts off N Oak Trafficway.

D. The plan must provide for safe, efficient, and convenient non-motorized travel opportunities, being pedestrian and bicycle movement, on the subject site;

There are sidewalks shown along the private drive to the west that will connect sidewalks around the building with a crosswalk.

E. The plan must provide for adequate utilities based on City standards for the particular development proposed.

Utilities are adequate to serve the site, subject to conditions.

F. The location, orientation, and architectural features, including design and material, of buildings and other structures on the site must be designed to be compatible with adjacent properties.

The building and drive-through configuration is consistent with Culver's on Lot 1; however, there is concern from staff and residents on N Oak Trafficway about the amount of drive-through lanes the overall plan allows that will contribute to noise, light, and engine idling. The previously approved plan and now proposed plan do not prioritize buildings fronting on the street and accommodating pedestrians from the neighborhoods across North Oak Trafficway to the east and apartments to the west.

G. Landscaping, berms, fences, and/or walls must be provided to buffer the site from undesirable views, noises, lighting, or other off-site negative influences and to buffer adjacent properties from negative influences that may be created by the plan.

The landscape plan shows screening of the drive-through that meets minimum Code requirements. Proposed shrubs are supposed to be 3 feet after the first growing season, which took the applicant two rounds of review to revise. Although 3 feet is the requirement, staff is concerned whether this will be adequate screening to buffer light, noise, and vehicle emissions from the residences across North Oak Trafficway. Additionally, staff asked the applicant to use native seed mix in the detention basin area to enhance stormwater absorption; however, the applicant declined this suggested revision.

H. The design of streets, drives, and parking areas within the project should result in a minimum of area devoted to asphalt or other impervious surfaces consistent with the needs of the project and city code requirements.

Proposed impervious surface is typical of a commercial development. The percentage of impervious surface was not provided on the plans.

- I. **The plan must identify trees to be removed and trees to be preserved during the development of the subject property with the goal of saving trees that are not required to be removed for the development of the property.**

There are no existing trees onsite.

Master Planned Developments (88-520-03-G)

In reviewing and making decisions on proposed MPD rezonings and preliminary development plans, review and decision-making bodies must consider at least the following factors:

- A. **The preliminary development plan's consistency with any adopted land use plans for the area;**

As previously discussed, the proposed plan and previously approved plan do not align with the future land use recommendation of Residential Medium High Density. Long Range Planning determined the plan is generally likely to align with other factors of the Gashland/Nashua Area Plan and KC Spirt Playbook.

During review and presentation of the previously approved MPD in February 2022, the City Plan Commission had a tied 3 to 3 vote on the motion to recommend approval of the case to City Council. Due to the tie vote, the Commission motioned to recommend "no recommendation" to the City Council. This case history shows the long-term concern over what was proposed for the MPD.

- B. **The preliminary development plan's consistency with the MPD district provisions of 88-280; and**

The previous versions of the MPD were rezoned on the basis of a mixed-use development with commercial and residential uses. A variety of uses does not automatically qualify as mixed-use development per the Code and best planning practices. Multiple drive-through facilities do not generally contribute to a true mixed-use development, which is meant to be pedestrian oriented.

The plan does not comply with Objective 4, "sustainable, long-term communities that provide opportunity and environmental and social equity for residents." The proposed plan contributes to vehicle-dominant uses that can result in health and safety hazards.

The plan does not comply with Objective 7, "a coordinated transportation systems that includes an inter-connected hierarchy of appropriately designed improvements for pedestrians, bicycles, and vehicles." The proposed plan has some pedestrian infrastructure as required by Code, but is primarily auto-dominant.

The plan does not comply with Objective 8, "compatibility of buildings and other improvements as determined by their arrangement, massing, form, character, and landscaping to establish a high-quality livable environment." Massing and form of the proposed building is compatible with the existing commercial buildings but does not establish a high-quality livable environment. The residents across North Oak Trafficway have expressed concerns to staff about increased vehicle idling, noise, light, and trash.

- C. **The sufficiency of the terms and conditions proposes to protect the interest of the public and the residents of the MPD in the case of a plan that proposes development over a long period of time.**

Staff has added a condition for the developer to install additional landscaping to what is shown on the plan to create a stronger buffer between the drive-through lanes and North Oak Trafficway and the

neighborhood to the east. Additionally, staff provided a condition for all lighting on the pad sites not to exceed what is recommended by the Illuminating Engineering Society.

ATTACHMENTS

1. Conditions Report
2. Applicants Submittal
3. Public Engagement Materials
4. Additional documents, if applicable

PROFESSIONAL STAFF RECOMMENDATION

City staff recommends **approval with conditions** as stated in the conditions report.

Respectfully Submitted,



Genevieve Kohn, AICP
Lead Planner



Plan Conditions

Report Date: November 14, 2024

Case Number: CD-CPC-2024-00149

Project: Popeyes at BB North Oak

Condition(s) by City Planning and Development Department. Contact Genevieve Kohn at (816) 513-8808 / Genevieve.Kohn@kcmo.org with questions.

1. This major amendment shall also serve as an MPD final plan for Lot 4.
2. The developer shall submit an affidavit, prepared by an engineer licensed in the State of Missouri, verifying that all outdoor lighting has been installed in accordance with approved plans and that lighting levels do not exceed that shown on the approved lighting plan at the property lines prior to Certificate of Occupancy.
3. All signage shall conform to 88-445 and shall require a sign permit prior to installation.
4. That prior to issuance of the Certificate of Occupancy for each lot within the plat the developer shall submit an affidavit, completed by a landscape architect licensed in the State of Missouri, verifying that street trees have been installed in accordance with the approved Street Tree Planting Plan and are healthy.
5. The developer shall screen all roof and/or ground mounted mechanical and utility equipment in compliance with 88-425-08.
6. The developer shall submit an affidavit, completed by an ISA certified arborist, an SAF certified forester, a professional engineer, or a landscape architect licensed in the State of Missouri, verifying that all trees preserved and all trees planted to meet mitigation required of the approved plan, whichever is applicable, has been installed or preserved in accordance with the plan and is healthy prior to Certificate of Occupancy.
7. The developer shall submit an affidavit, completed by a landscape architect licensed in the State of Missouri, verifying that all landscaping required of the approved plan has been installed in accordance with the plan and is healthy prior to Certificate of Occupancy.
8. That Ordinance No. 220235, including all conditions provided therein, shall remain in full force and effect.
9. The developer shall provide an additional layer of landscape screening along the drive-through fronting N Oak Trfy with varieties of Juniperus virginiana, Thuja occidentalis, or Viburnum.
10. Spillover light from signage, on any lot within the MPD, onto R-zoned property or public rights-of-way may not exceed 2 lux, measured at grade along the property line.
11. All lighting shall not exceed the recommend levels of the Illuminating Engineering Society on all lots within the MPD.
12. The applicant shall revise plans prior to ordinance request to address Public Works - Mobility's correction: Provide a sidewalk connection from N Oak Trafficway. Right now pedestrian path is to go all the way around to the private drive. It could also go from NE 96th Terr to the east side of the building if preferred.

Condition(s) by Public Works Department. Contact Terry Thomas at (816) 513-2510 / Terry.A.Thomas@kcmo.org with questions.

13. The developer shall pay impact fees as required by Chapter 39 of the City's Code of ordinances as required by the Land Development Division.
14. The developer shall submit a letter to the Land Development Division from a Licensed Civil Engineer, Licensed Architect, or Licensed Landscape Architect, who is registered in the State of Missouri, that identifies sidewalks, curbs, and gutters in disrepair as defined by Public Works Department's "OUT OF REPAIR CRITERIA FOR SIDEWALK, DRIVEWAY AND CURB revised 11/5/2013" and based on compliance with Chapters 56 and 64 of the Code of Ordinances for the sidewalks, curbs, and gutters where said letter shall identify the quantity and location of sidewalks, curbs, gutters that need to be constructed, repaired, or reconstructed to remedy deficiencies and/or to remove existing approaches no longer needed by this project. The developer shall secure permits to repair or reconstruct the identified sidewalks, curbs, and gutters as necessary along all development street frontages as required by the Land Development Division and prior to issuance of any certificate of occupancy permits including temporary certificate occupancy permits.

Condition(s) by Water Services Department. Contact Heather Massey at (816) 513-2111 / heather.massey@kcmo.org with questions.

15. The developer shall ensure that water and fire service lines should meet current Water Services Department Rules and Regulations. Prior to C of O.

<https://www.kcwater.us/wp-content/uploads/2022/05/2022-Rules-and-Regulations-for-Water-Service-Lines-Final.pdf>

Condition(s) by Water Services Department. Contact Kirk Rome at (816) 513-0368 / kirk.rome@kcmo.org with questions.

16. Trees shall not be planted in the existing water easement along North Oak.
Any grading within the existing water easement shall receive pre-approval from the KC Water Director.

Condition(s) by Water Services Department. Contact Lucas Kaspar at (816) 513-2131 / Lucas.Kaspar@kcmo.org with questions.

17. The developer shall submit a detailed Micro storm drainage analysis from a Missouri-licensed civil engineer to KC Water showing compliance with the current, approved Macro study on file with the City and with current adopted standards in effect at the time of submission, including Water Quality BMP's, prior to approval and issuance of any building permits to construct improvements on the site or prior to recording the plat, whichever occurs first. The developer shall verify and/or improve downstream conveyance systems or address solutions for impacted properties due to flow contributions from the site; and that the developer construct any other improvements as required by KC Water as necessary to mitigate impacts from rate, volume, and quality of runoff from each proposed phase.
18. The developer must grant a BMP Easement to the City as required by KC Water, prior to recording the plat or issuance of any building permits.

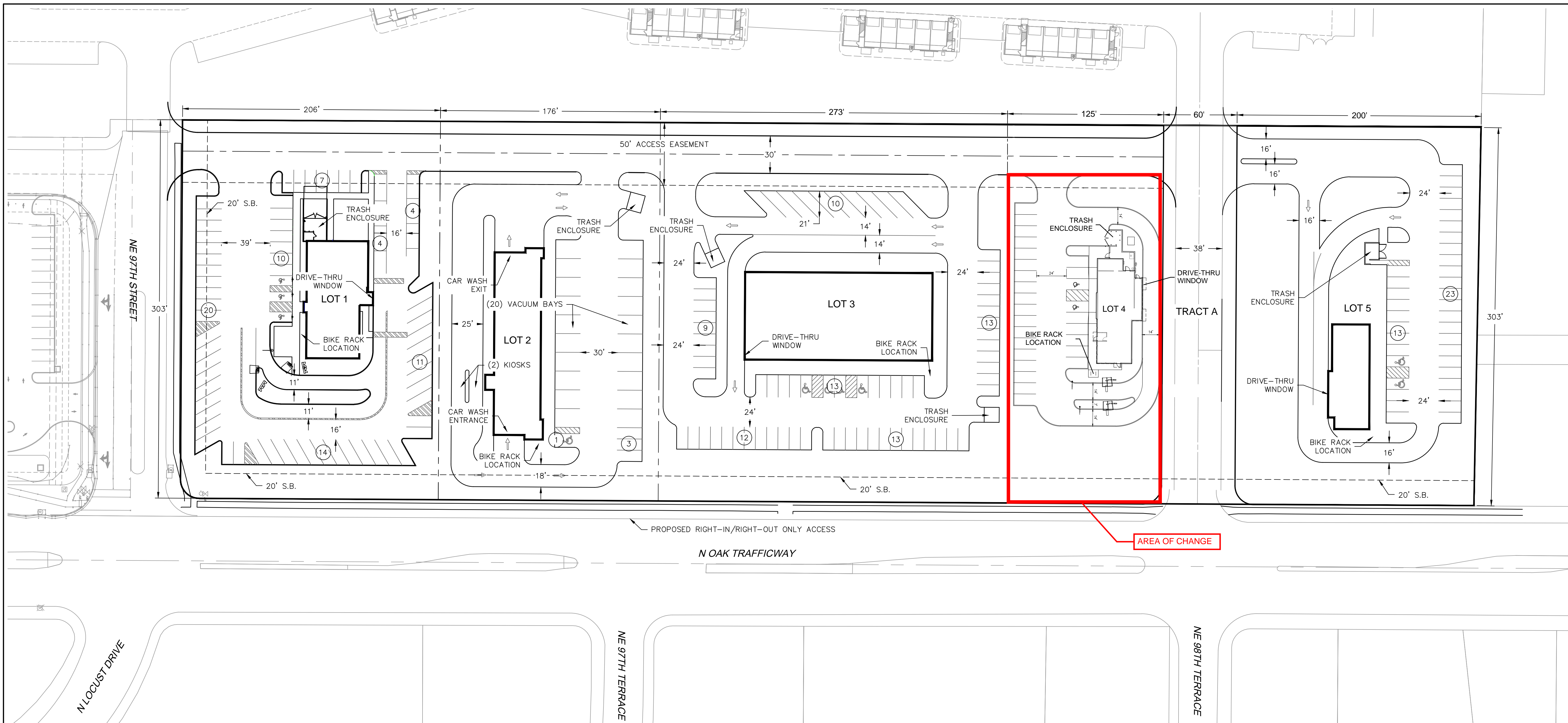

TABLE 1: SITE DATA

SITE DATA	EXISTING	PROPOSED	DEVIATION REQUESTED?	APPROVED
ZONING	MPD	MPD	NO	N/A
GROSS LAND AREA				
- IN SQUARE FEET	313,818	313,818	NO	N/A
- IN ACRES	7.20	7.20	NO	N/A
RIGHT-OF-WAY DEDICATION				
- IN SQUARE FEET	0	0	NO	N/A
- IN ACRES	0	0	NO	N/A
BUILDING AREA (SQ. FT.)	0	28,200	NO	N/A
F.A.R.	0	0.09	NO	N/A
RESIDENTIAL USE INFO	N/A	N/A	NO	N/A
TOTAL LOTS				
- RESIDENTIAL			NO	N/A
- PUBLIC/CIVIC			NO	N/A
- COMMERCIAL		5	NO	N/A
- INDUSTRIAL		0	NO	N/A
- OTHER		1	NO	N/A

TABLE 2: BUILDING DATA

SITE DATA	EXISTING	PROPOSED	DEVIATION REQUESTED?	APPROVED
REAR SETBACK	NONE	NONE	NO	N/A
FRONT SETBACK	NONE	20 FT.	NO	N/A
SIDE SETBACK	NONE	NONE	NO	N/A
SIDE SETBACK (ABUTTING STREET)	NONE	20 FT.	NO	N/A
HEIGHT	NONE	30 FT.	NO	N/A

DEVELOPMENT DATA TABLE

CATEGORY (Item)	EX. ZONING (a)	PR. ZONING (a)	GROSS AREA (AC.) (b)	EXISTING R/W (AC.) (c)	PROPOSED R/W (AC.) (c)	NET AREA (AC.) (d)	USE (e)	NUMBER OF FLOORS (f)	MAX. BUILDING HEIGHT (FT.) (f)	GROSS BUILDING AREA (SF) (g)	BUILDING COVERAGE (SF) (h)	F.A.R. (h)	PARKING STALLS REQUIRED			LONG-TERM BICYCLE PARKING STALLS REQUIRED			SHORT-TERM BICYCLE PARKING STALLS			COMMENCEMENT DATE (l)	COMPLETION DATE (l)	
													Ratio (j)	Required (j)	Provided (j)	Ratio (k)	Required (k)	Provided (k)	Ratio (k)	Required (k)	Provided (k)			
LOT 1	MPD	MPD	1.43	0.00	0.00	1.43	Restaurant Drive Thru	1	30	4,500	4,500	0.07	10 per 1000 SF	45	70	1 + 1 per 5,000 SF	2	2	10% of vehicular (min. 3)	7	8			
LOT 2	MPD	MPD	1.19	0.00	0.00	1.22	Car Wash Drive Thru	1	30	6,000	6,000	0.11	None	0	4	1 + 1 per 10,000 SF	2	2	10% of vehicular (min. 3)	3	4			
LOT 3	MPD	MPD	2.00	0.00	0.00	1.93	Retail & Restaurant Drive Thru	1	30	12,000	12,000	0.14	2.5 per 1000 SF (retail) 10 per 1000 SF (rest.)	70 max.	70	1 + 1 per 10,000 SF (retail) 1 + 1 per 5,000 SF (rest.)	4 max.	4	10% of vehicular (min. 3)	7	8	2022	2025	
LOT 4	MPD	MPD	0.87	0.00	0.00	0.87	Restaurant Drive Thru	1	30	2,700	2,700	0.07	10 per 1000 SF	27	27	1 + 1 per 5,000 SF	2	2	10% of vehicular (min. 3)	3	4			
LOT 5	MPD	MPD	1.34	0.00	0.00	1.34	Restaurant Drive Thru	1	30	3,000	3,000	0.05	10 per 1000 SF	30	36	1 + 1 per 5,000 SF	2	2	10% of vehicular (min. 3)	4	4			
TRACT A	MPD	MPD	0.41	0.00	0.00	0.41	Access Tract																Existing	
TOTAL			7.20	0.00	0.00	7.20				28,200	28,200	0.09		172	207		12	12		24	28			

TABLE 4: PARKING DATA

88-420 PARKING	VEHICLE SPACES		BIKE SPACES		ALTERNATIVES PROPOSED?
	REQUIRED	PROPOSED	REQUIRED (LONG/SHORT)	PROPOSED (LONG/SHORT)	
LOT 1	45	70	2/7	2/8	NO
LOT 2	0	4	2/3	2/4	NO
LOT 3	70 MAX.	70	4/7	2/8	NO
LOT 4	27	27	2/3	2/4	NO
LOT 5	30	36	2/4	2/4	NO
TRACT A	N/A	N/A	N/A	N/A	NO
TOTAL	172	207	12/24	12/28	NO

- NOTES:
- PROPOSED HEAD-IN PARKING SPACES SHALL BE A MINIMUM OF 9' WIDE BY 18' LONG. PROPOSED PARALLEL PARKING SPACES SHALL BE A MINIMUM OF 9' WIDE BY 22' LONG. PARKING LOT DESIGN SHALL MEET STANDARDS IN 88-420-15.
 - PROPOSED LOTS MAY BE SUBDIVIDED IN THE FUTURE VIA MINOR SUBDIVISION PLAT.

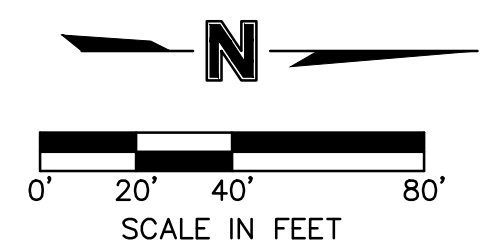

PHILIPS ENGINEERING, INC.
1370 N. Winchester
Olathe, Kansas 66061
(913) 393-1155
Fax (913) 393-1166
www.philipsengineering.com



REV. NO.	DATE	REVISIONS DESCRIPTION	BY

SITE PLAN & PRELIMINARY PLAT
BB N OAK DEV CO LLC PROPERTY
MPD DEVELOPMENT PLAN

KANSAS CITY, MO

drawn by: AEB
checked by: DAF
approved by: JDC
QA/QC by: JDC
project no.: 240374
drawing no.: 1
date: 09-29-2024

SITE DEVELOPMENT PLANS FOR POPEYE'S LOUISIANA KITCHEN

ADDRESS: 9806 N. OAK TRAFFICWAY
IN THE CITY OF KANSAS CITY, CLAY COUNTY, MISSOURI

INDEX	
C000	COVER SHEET
C001	GENERAL NOTES
C002	DEMOLITION PLAN
C100	SITE PLAN
C200	GRADING PLAN
C300	UTILITY PLAN
C400	STORM SEWER PLAN & PROFILES
C401	INFILTRATION TRENCH DETAILS
C500	DRAINAGE MAP & CALCULATIONS
LS-1	LANDSCAPE PLAN
	SITE PHOTOMETRIC PLAN
	ARCHITECTURAL PLANS



COVER SHEET
POPEYE'S LOUISIANA KITCHEN
KANSAS CITY, CLAY COUNTY, MISSOURI
SITE ADDRESS: 9806 N. OAK TRAFFICWAY

UTILITY COMPANIES:

- SPIRE ENERGY (816) 472-3434
BEVERLY PASSANTINO
7500 E. 35TH TERRACE
KANSAS CITY, MO. 64129
EMAIL: beverly.passantino@spireenergy.com
- EVERGY (816) 420-4721
MELISSA FELTES
8325 N. PLATTE PURCHASE DRIVE
KANSAS CITY, MO. 64118
E-MAIL: Melissa.Feltes@kcpl.com
- AT&T (816) 734-8700
JILL SCHROEDER
9556 N. MCGEE COURT
KANSAS CITY, MO 64155
EMAIL: j0311@att.com
- CITY OF KANSAS CITY (816) 513-2627
PUBLIC WORKS DEPARTMENT
414 E. 12TH STREET
KANSAS CITY, MO. 64106
- CITY OF KANSAS CITY (GENERAL NUMBER) (816) 513-1313
CARLA HASKINS (WATER) (816) 513-2133
EMAIL: carla.haskins@kcmo.org
AMY BUNNELL (LAND DEVELOPMENT DIVISION) (816) 513-2552
EMAIL: amy.bunnell@kcmo.org
4800 E. 63RD STREET
KANSAS CITY, MO. 64130
- TIME WARNER CABLE (816) 358-8833
15 NW BARRY ROAD
KANSAS CITY, MO. 64155

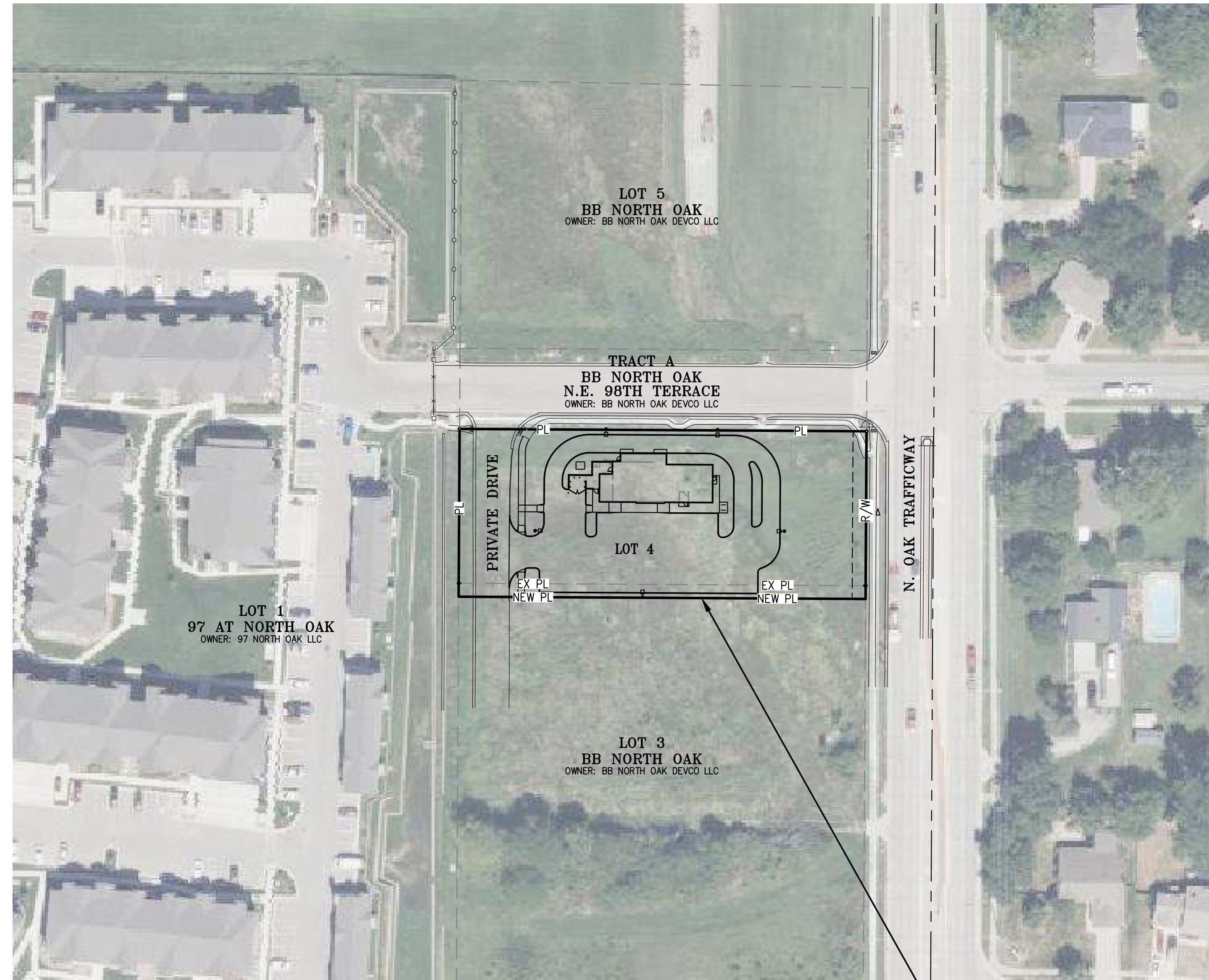

PREPARED & SUBMITTED BY:

PHELPS ENGINEERING, INC.
1270 N. WINCHESTER
OLATHE, KS 66061
913-393-1155 OFFICE
913-393-1166 FAX
CONTACT: JUDD CLAUSSEN, P.E.

OWNER:

BB NORTH OAK DEVCO, LLC
7121 W. 79TH STREET
OVERLAND PARK, KS 66204
CONTACTS: DOUG HENZLIK, JODY STRINGER
PHONE: 913-725-0406

DEVELOPER:

CSM GROUP
10190 KATY FREEWAY, SUITE 350
HOUSTON, TX 77043
CONTACTS: FELIX ZAMIKOVSKY
PHONE: 713-907-2840

BENCHMARK:

VERTICAL DATUM = NAVD88 BASED ON GPS OBSERVATION USING SMARTNET GPS NETWORK
1. SET "1" CUT IN CENTER FRONT FACE OF CURB INLET N. SIDE OF 98TH TERR. NORTH OF NW COR. OF PROPERTY
ELEVATION = 1023.92

LEGAL DESCRIPTION:

LOT 4, BB NORTH OAK, TOGETHER WITH THE NORTH 10 FT OF LOT 3, BB NORTH OAK, A SUBDIVISION IN KANSAS CITY, CLAY COUNTY, MISSOURI.

GROSS AREA = ±0.8665 ACRES / ±37,745 SQ.FT.

FLOOD NOTE:

THIS PROPERTY LIES WITHIN ZONE X, DEFINED AS AREAS DETERMINED TO BE OUTSIDE THE 0.2% ANNUAL CHANCE FLOODPLAIN, AS SHOWN ON THE FLOOD INSURANCE RATE MAP PREPARED BY THE FEDERAL EMERGENCY MANAGEMENT AGENCY FOR KANSAS CITY, COMMUNITY NO. 290173, CLAY COUNTY, MISSOURI, MAP NO. 29095C00646, AND DATED JANUARY 20, 2017.

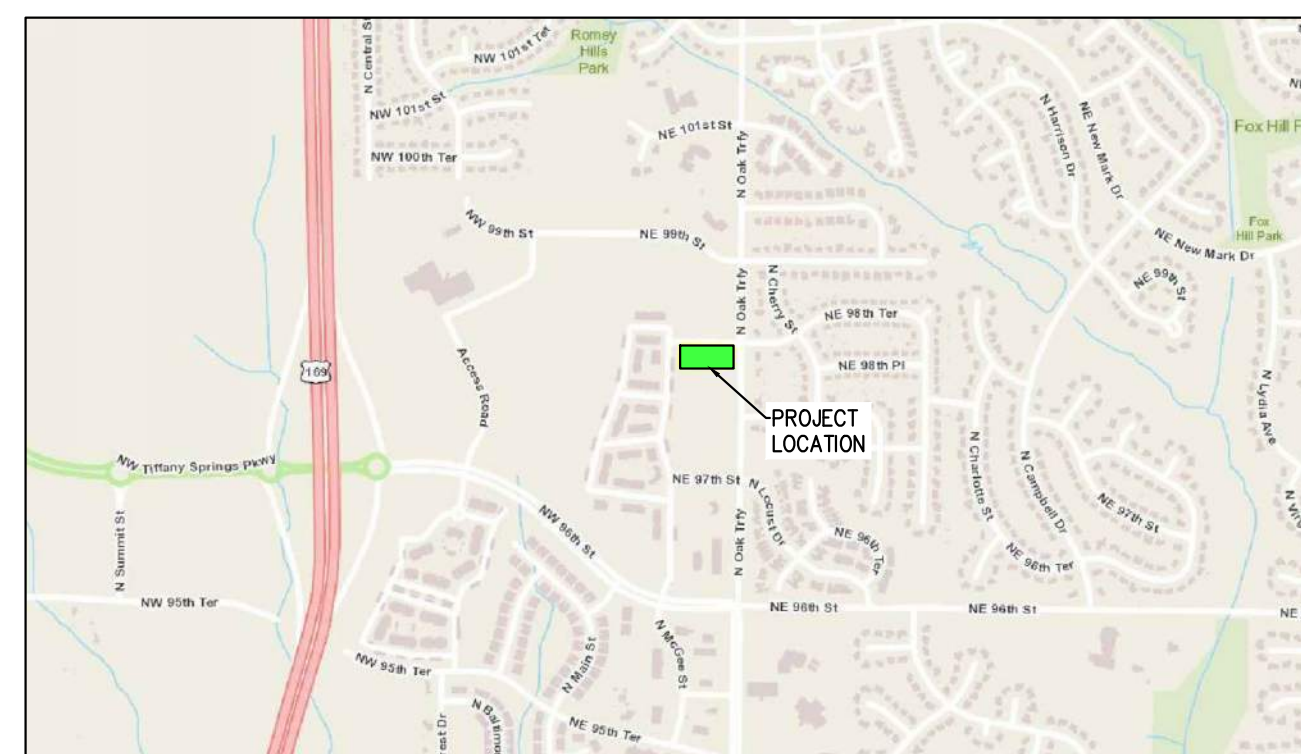

VICINITY MAP
NOT TO SCALE

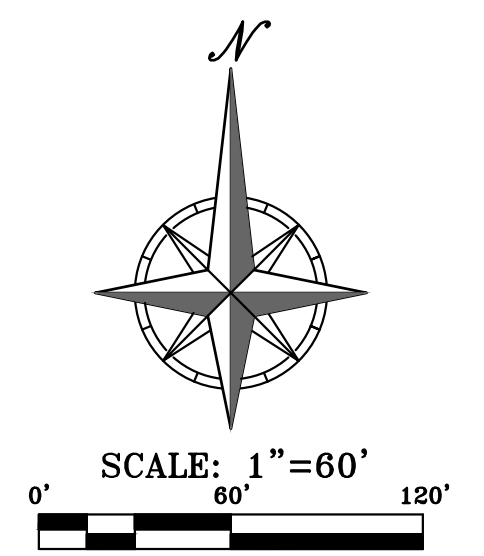

Know what's below.
Call before you dig.

UTILITY NOTES:
VISUAL INDICATIONS OF UTILITIES ARE AS SHOWN. UNDERGROUND LOCATIONS SHOWN, AS FURNISHED BY THEIR LESSORS, ARE APPROXIMATE AND SHOULD BE VERIFIED IN THE FIELD AT THE TIME OF CONSTRUCTION. FOR ACTUAL FIELD LOCATIONS OF UNDERGROUND UTILITIES CALL 811.

PROJECT NO.	DATE	BY	APP.	REVISIONS
230374	09-29-2024	DAW/AEB	DAW/AEB	
		CHECKED: DAF	APPROVED: DAF	
		CERTIFICATE OF AUTHORIZATION		
		LAND SURVEYING - LS-82		
		ENGINEERING - E-361		
		CERTIFICATE OF AUTHORIZATION		
		LAND SURVEYING-200701028		
		ENGINEERING-200300038		

SHEET
C000

\\PHELPS-SERVER\Projects\1440374\Drawings\Permit Plans\COVER.dwg Layout:1 Oct 20, 2024 - 8:29pm Danila Finn

DEMOLITION NOTES:

- 1. THE CONTRACTOR IS RESPONSIBLE FOR THE DEMOLITION, REMOVAL, AND DISPOSAL (IN A LOCATION APPROVED BY ALL GOVERNING AUTHORITIES) ALL CURBS, PARKING, DRIVES, DRAINAGE STRUCTURES, UTILITIES, ETC., SUCH THAT THE IMPROVEMENTS SHOWN ON THE REMAINING PLANS CAN BE CONSTRUCTED. ALL FACILITIES TO BE REMOVED SHALL BE UNDERCUT TO SUITABLE MATERIAL AND BROUGHT TO GRADE WITH SUITABLE COMPACTED FILL MATERIAL.
2. THE CONTRACTOR IS RESPONSIBLE FOR REMOVING ALL DEBRIS FROM THE SITE AND DISPOSING THE DEBRIS IN A LAWFUL MANNER. THE CONTRACTOR IS RESPONSIBLE FOR OBTAINING ALL PERMITS REQUIRED FOR DEMOLITION AND DISPOSAL.
3. DAMAGE TO ALL EXISTING CONDITIONS TO REMAIN WILL BE REPLACED AT CONTRACTOR'S EXPENSE.
4. CONTRACTOR MUST COORDINATE WITH OWNER PRIOR TO ANY CONSTRUCTION TO ESTABLISH CUSTOMER ACCESS AND TRAFFIC FLOW DURING ALL PHASES.
5. REFER TO THE BUILDING PLANS FOR SITE LIGHTING ELECTRICAL MODIFICATIONS (IF ANY) TO THE EXISTING SYSTEM.

SITE PLAN NOTES:

- 1. All construction materials and procedures on this project shall conform to the latest revision of the following governing requirements, incorporated herein by reference.
A) City ordinances & O.S.H.A. Regulations.
B) The City of Kansas City, Missouri Technical Specifications and Municipal Code.
C) APWA Standard Specifications and Design Criteria, latest edition.
D) Project Specific Specifications.
2. The contractor shall have one (1) signed copy of the plans (approved by the City) and one (1) copy of the appropriate Design and Construction Standards and Specifications at the job site at all times.
3. The contractor will be responsible for securing all permits, bonds and insurance required by the contract documents, City of Kansas City, Missouri, and all other governing agencies (including local, county, state and federal authorities) having jurisdiction over the work proposed by these construction documents. The cost for all permits, bonds and insurance shall be the contractor's responsibility and shall be included in the bid for the work.
4. The contractor is responsible for coordination of his and his sub-contractor's work. The contractor shall assume all responsibility for protecting and maintaining his work during the construction period and between the various trades/sub-contractors constructing the work.
5. The demolition and removal/relocation of existing pavement, curbs, structures, utilities, and all other features necessary to construct the proposed improvements, shall be performed by the contractor. All waste material removed during construction shall be disposed off the project site. The contractor shall be responsible for all permits for hauling and disposing of waste material. The disposal of waste material shall be in accordance with all local, state and federal regulations.
6. Contractor shall be responsible for all relocations, including but not limited to, all utilities, storm drainage, sanitary sewer services, signs, traffic signals & poles, etc., as required. All work shall be in accordance with governing authorities specifications and shall be approved by such. All cost shall be included in base bid.
7. All existing utilities indicated on the drawings are according to the best information available to the Engineer; however, all utilities actually existing may not be shown. The contractor shall be responsible for contacting all utility companies for an exact field location of each utility prior to any construction. All utilities, shown and unknown, damaged through the negligence of the contractor shall be repaired or replaced by the contractor at his expense.
8. The contractor will be responsible for all relocations, utilities, pavement, fences, structures and other features not designated for removal. The contractor shall repair all damages at his expense.
9. The contractor shall verify the flow lines of all existing storm or sanitary sewer connections and utility crossings prior to the start of construction. Notify the engineer of any discrepancies.
10. SAFETY NOTICE TO CONTRACTOR: In accordance with generally accepted construction practices, the contractor shall be solely and completely responsible for conditions of the job site, including safety of all persons and property during performance of the work. This requirement will apply continuously and not be limited to normal working hours. Any construction observation by the engineer of the contractor's performance is not intended to include review of the adequacy of the contractor's safety measures, in, on or near the construction site.
11. WARRANTY/DISCLAIMER: The designs represented in these plans are in accordance with established practices of civil engineering for the design functions and uses intended by the owner at this time. However, neither the Engineer nor its personnel can or do warrant these designs or plans as constructed except in the specific cases where the Engineer observes the physical construction on a continual basis at the site.
12. No work is to be allowed within the public right-of-way or easements without a right of way work permit.
13. All paving construction and earthwork grading/compaction shall conform to the requirements of the geotechnical engineering report prepared for this project.
14. Within forty-eight hours prior to any asphalt or concrete paving, the subgrade shall be proof rolled with a fully loaded tandem wheeled dump truck and observed by the on-site geotechnical engineer. Areas of the subgrade with excessive rutting and/or pumping shall be re-worked or removed in accordance with the project specifications. Flyash or granular material may be added by the contractor to stabilize the subgrade. See project specifications.
15. All curb shall be sloped for positive drainage. Contractor shall use "dry curb and gutter" as needed in localized paved areas that drain away from the curb and gutter. See paving details.
16. The Contractor is responsible for the protection all property corners and section corners. Any property corners and/or section corners disturbed or damaged by construction activities shall be reset by a Registered Land Surveyor licensed in the State of Kansas, at the contractor's expense.
17. The contractor shall be responsible for the restoration of the right-of-way and for damaged improvements such as curbs, sidewalks, street light and traffic signal junction boxes, traffic signal loop lead line, signal poles, etc. Damaged improvements shall be repaired in conformance with the latest city standards and to the City's satisfaction.
18. The contractor is responsible for providing berms, silt fences, straw bales, or other means to prevent eroded materials from reaching the public right-of-way and adjacent properties. In the event the prevention measures are not effective, the contractor shall remove any debris, silt or mud and restore the right-of-way or adjacent property to original or better condition.
19. All disturbed areas are to receive topsoil, sod and water until a healthy stand of grass is established. See the landscaping plans for requirements. Re-seeding shall be required (see project specifications).
20. The contractor shall sod all disturbed areas within the public street right-of-way.
21. Contractor shall refer to the architectural building plans for exact locations and dimensions of vestibules, slope paving, sidewalks, exit porches, truck docks, precise building dimensions and exact building utility entrance locations. All dimensions are to outside wall of building(s).
22. Refer to building plans for site lighting electrical plan.
23. Contractor to remove existing trees and vegetation, as necessary, for site construction unless specifically noted to remain.
24. Refer to the building plans for site lighting electrical requirements, including conduits, pole bases, pull boxes, etc.

SITE DIMENSION NOTES:

- 1. BUILDING TIES SHOWN ARE TO THE OUTSIDE FACE OF PROPOSED WALLS. THE SUBCONTRACTOR SHALL REFER TO THE ARCHITECTURAL PLANS FOR SPECIFIC DIMENSIONS AND LAYOUT INFORMATION FOR THE BUILDINGS.
2. ALL DIMENSIONS SHOWN FOR THE PARKING LOT AND CURBS ARE MEASURED FROM BACK OF CURB TO BACK OF CURB.

PAVEMENT MARKING AND SIGNAGE NOTES:

- 1. PARKING STALL MARKING STRIPES SHALL BE FOUR INCH (4") WIDE WHITE STRIPES. DIRECTIONAL ARROW AND HANDICAP STALL MARKINGS SHALL BE FURNISHED AT LOCATIONS SHOWN ON PLANS.
2. HANDICAP PAVEMENT MARKINGS AND SIGNS SHALL CONFORM TO ALL FEDERAL (AMERICANS WITH DISABILITIES ACT) AND STATE LAWS AND REGULATIONS.
3. TRAFFIC CONTROL DEVICES AND PAVEMENT MARKINGS SHALL CONFORM TO THE REQUIREMENTS OF THE "MANUAL OF UNIFORM TRAFFIC CONTROL DEVICES".
4. STOP SIGNS SHALL BE PROVIDED AT ALL LOCATIONS AS SHOWN ON PLANS AND SHALL CONFORM TO THE "MANUAL OF UNIFORM TRAFFIC CONTROL DEVICES". SIGNS SHALL BE 18" X 12", 18 GAUGE STEEL AND SHALL BE ENGINEER GRADE REFLECTIVE.
5. TRAFFIC CONTROL AND PAVEMENT MARKINGS SHALL BE PAINTED WITH A WHITE SHERWIN WILLIAMS S-W TRAFFIC MARKING SERIES B-29Y2 OR APPROVED EQUAL. THE PAVEMENT MARKING SHALL BE APPLIED IN ACCORDANCE WITH MANUFACTURERS RECOMMENDATIONS. APPLY ON A CLEAN, DRY SURFACE AND AT A SURFACE TEMPERATURE OF NOT LESS THAN 70F AND THE AMBIENT AIR TEMPERATURE SHALL NOT BE LESS THAN 60F AND RISING. TWO COATS SHALL BE APPLIED.

SITE GRADING NOTES:

- 1. CONTOURS AND ELEVATIONS: Existing and proposed contours are shown on plans at one foot (1') contour intervals, unless otherwise noted, proposed contours and elevations shown represent approximate finish grade. Contractor shall hold down subgrades to allow for pavement and sub-base thicknesses.
2. If the contractor does not accept existing topography as shown on the plans, without exception, he shall have made at his expense, a topographic survey by a registered land surveyor and submit it to the owner for review.
3. CLEARING AND GRUBBING: Prior to beginning preparation of subgrade, all areas under pavements or building shall be stripped of all topsoil, vegetation, large rock fragments (greater than 6 inches in any dimension) and any other deleterious material. The actual stripping depth should be based on visual examination during construction and the results of proof-rolling operations. The root systems of all trees (not designated to remain) shall be removed in their entirety. Stripping materials shall not be incorporated into structural fills.
4. TOPSOIL STRIPPING: Prior to the start of site grading, the contractor shall strip all topsoil from areas to be graded, and stockpiled at a location on or adjacent to the site as directed by the owner. At completion of grading operations and related construction, the contractor will be responsible for redistribution of topsoil over all areas disturbed by the construction activities. Topsoil shall be placed to a minimum depth of six inches (6") and in accordance with specifications for landscaping. At that time, and prior to the installation of landscaping or irrigation, all topsoil graded areas shall be visually inspected and accepted by the owner and ILL.
5. Contractor shall adjust and/or cut existing pavement as necessary to assure a smooth fit and continuous grade. Contractor shall assure positive drainage away from buildings for all natural and paved areas.
6. SUBGRADE PREPARATION: Prior to placement of new fill material, the existing subgrade shall be proofrolled and approved under the direction of the Geotechnical Engineer or his representative.
7. PROOFROLLING: Subsequent to completion of stripping and over-excavation, all building and pavement areas to receive engineered fill shall be systematically proof-rolled using a tandem axle dump truck loaded to approximately 20,000 pounds per axle. Also, any finished subgrade areas to receive paving shall be proof-rolled within 48 hours of paving. Unsuitable soils that are detected and that can not be recompacted should be over-excavated and replaced with controlled structural fill.
8. EARTHWORK:
A) GEOTECHNICAL: All earthwork shall conform to the recommendations of the Geotechnical report. Said report and its recommendations are herein incorporated into the project requirements by reference. Prior to beginning construction, the contractor shall obtain a copy of and become familiar with the geotechnical report. Unless specifically noted on the plans, the recommendations in the geotechnical report are hereby incorporated into the project requirements and specifications.
B) SURFACE WATER: Surface water shall be intercepted and diverted during the placement of fill.
C) FILLS: All fills shall be considered controlled or structural fill and shall be free of vegetation, organic matter, topsoil and debris. In areas where the thickness of the engineered fill is more than five, feet building and pavement construction should not commence until so authorized by the on-site geotechnical engineer to allow for consolidation.
D) BUILDING SUBGRADE: As specified in the Geotechnical Engineering Report, the upper section of building subgrade shall consist of Low Volume Change (LVC) material defined as approved, compacted granular fill or low to moderate plasticity cohesive soil materials stabilized with Class C Flyash. Granular fill shall consist of compacted granular materials with a maximum particle size of two (2) inches or less, such as limestone screenings. Refer to geotechnical report for complete requirements.
E) EXISTING SLOPES: Where fill material is to be placed on existing slopes greater than 5:1 (horizontal to vertical), existing slope shall be benched providing a minimum vertical face of twelve inches (12"). The benches shall be cut wide enough to accommodate the compaction equipment. Fill material shall be placed and compacted in horizontal lifts not exceeding nine inches (9") (loose lift measurement), unless otherwise approved by the Geotechnical Engineer.
F) COMPACTION REQUIREMENTS: The upper 9 inches of pavement subgrade areas shall be compacted to a minimum density of ninety five percent (95%) of the material's maximum dry density as determined by ASTM D698 (standard proctor compaction). The moisture content at the time of placement and compaction shall within a range of 0% below to 4% above optimum moisture content as defined by the standard proctor compaction procedure. The moisture contents shall be maintained within this range until completion of the work. Where compaction of earth fill by a large roller is impractical or undesirable, the earth fill shall be hand compacted with small vibrating rollers or mechanical tampers.
9. All cut or fill slopes shall be 3:1 or flatter. All asphalt parking areas shall be a minimum of 1% slope but not more than 5% slope unless otherwise noted. All pavements within ADA parking areas shall not exceed 2% total slope. All grades around building shall be held down 6" from finish floor and slope away another 6" in 10 feet. Contractor shall notify engineer prior to final subgrade construction of any areas not within this slope requirement.
10. TESTING AND INSPECTION: Owner's Independent Testing Laboratory (ITL) shall make tests of earthwork during construction and observe the placement of fills and other work performed on this project to verify that work has been completed in accordance with Geotechnical Engineering Report, Project Specifications and within industry standards. The ITL will be selected by the owner and the cost of testing will be the owner's responsibility.
11. CLASSIFICATION: All excavation shall be considered unclassified. No separate or additional payments shall be made for rock excavation.
12. PERMANENT RESTORATION: All areas disturbed by earthwork operations shall be sodded, unless shown otherwise by the landscaping plan or erosion control plan.
13. UTILITIES: The contractor is specifically cautioned that the location and/or elevation of existing utilities as shown on these plans is based on records of the various utility companies, and where possible, measurements taken in the field. The information is not to be relied on as being exact or complete. The contractor must call the appropriate utility companies at least 48 hours before any excavation to request exact field location of utilities. It shall be the responsibility of the contractor to relocate all existing utilities which conflict with the proposed improvements shown on the plans.
14. LAND DISTURBANCE: The contractor shall adhere to all terms & conditions as outlined in the EPA or applicable state N.P.D.E.S. permit for storm water discharge associated with construction activities. Refer to project S.W.P.P.P. requirements.

UTILITY NOTES:

- 1. The contractor is specifically cautioned that the location and/or elevation of existing utilities as shown on these plans is based on records of the various utility companies, and where possible, measurements taken in the field. The information is not to be relied on as being exact or complete. The contractor must call the appropriate utility companies at least 48 hours before any excavation to request exact field location of utilities. It shall be the responsibility of the contractor to coordinate with and relocate &/or remove all existing utilities which conflict with the proposed improvements shown on the plans.
2. The construction of storm sewers on this project shall conform to the requirements of the City's Technical Specifications and Design Criteria.
3. The contractor shall field verify the exact location and elevation of the existing storm sewer lines and the existing elevation at locations where the proposed storm sewer collects or releases to existing ground. If discrepancies are encountered from the information shown on the plans, the contractor shall contact the design engineer. No pipes shall be laid until direction is received from the design engineer.
4. It will be the contractor's responsibility to field adjust the top of all manholes and boxes as necessary to match the grade of the adjacent area. Tops of existing manholes shall be raised as necessary to be flush with proposed pavement elevations, and to be 6-inches above finished ground elevations in non-paved areas. No separate or additional compensation will be made to the contractor for making final adjustments to the manholes and boxes.
5. Inlet locations, horizontal pipe information and vertical pipe information is shown to the center of the structure. Deflection angles shown for storm sewer pipes are measured from the center of curb inlets and manholes. The contractor shall adjust the horizontal location of the pipes to go to the face of the boxes. All roof drains shall be connected to storm sewer structures. Provide cleanouts on roof drain lines at 100' max. Spacing and at all bend points. Do not connect roof drains directly to storm sewer pipe.
6. The contractor shall be responsible for furnishing and installing all fire and domestic water lines, meters, backflow devices, pits, valves and all other incidents required for a complete operable fire protection and domestic water system. All costs associated with the complete water system for the buildings shall be the responsibility of the contractor. All work shall conform to the requirements of City.
7. The contractor shall be responsible for furnishing and installing all sanitary sewer service lines from the buildings to the public line. All work shall conform to the requirements of the City.
8. The contractor will be responsible for securing all permits, bonds and insurance required by the contract documents, City, and all other governing agencies (including local, county, state and federal authorities) having jurisdiction over the work proposed by these construction documents. The cost for all permits bonds and insurance shall be the contractor's responsibility and shall be included in the bid for the work.
9. By the use of these construction documents the contractor hereby agrees that he/she shall be solely responsible for the safety of the construction workers and the public. The contractor agrees to hold the engineer and owner harmless for any and all injuries, claims, losses or damages related to the project.
10. The Contractor shall be responsible for furnishing all materials, tools and equipment and installation of electrical power, telephone and gas service from a point of connection from the public utility lines to the building structures. This will include all conduits, service lines, meters, concrete pads and all other incidents required for a complete and operational system as required by the owner and the public utilities. Refer to building plans for exact tie-in locations of all utilities. Contractor shall verify connection points prior to installation of utility line.
11. All fill material is to be in place, compacted, and consolidated before installation of proposed utilities. On-site geotechnical engineer shall provide written confirmation that this requirement has been met and that utilities may proceed in the fill areas. All utilities are to be placed in trench conditions.
12. Contractor shall notify the utility authorities inspectors 48 hours before connecting to any existing line.
13. Water lines shall be as follows (unless otherwise shown on plans):
- Pipe sizes less than 3-inches that are installed below grade and outside building shall comply with the following:
1. Seamless Copper Tubing: Type "K" soft copper, ASTM B88.
2. Fittings: Wrought copper (95.5 Tin Antimony solder joint), ASME B 16.22.
14. Minimum trench width shall be 2 feet.
15. Contractor shall maintain a minimum of 42" cover on all waterlines. All water line joints are to be mechanical joints with thrust blocking as called out in specifications and construction plans. Water mains and service lines shall be constructed in accordance to City's specifications for commercial services.
16. All waterlines shall be kept min. ten (10') apart (parallel) from sanitary sewer lines or manholes. Or when crossing, a 24" vertical clearance (outside edge of pipe to outside edge of pipe) of the water line above the sewer line is required.
17. Sanitary conflicts will be resolved prior to permit issuance.
18. All underground storm, sanitary, water and other utility lines shall be installed, inspected and approved before backfilling. Failure to have inspection approval prior to backfill will constitute rejection of work.
19. All necessary inspections and/or certifications required by codes and/or utility service companies shall be performed prior to announced building possession and the final connection of service. Contractor shall coordinate with all utility companies for installation requirements and specifications.
20. Refer to building plans for site lighting electrical plan, irrigation, parking lot security system and associated conduit requirements. Coordinate with Owner that all required conduits are in place & tested prior to paving.
21. When a building utility connection from site utilities leading up to the building cannot be made immediately, temporarily mark all such site utility terminations.
22. Refer to the building plans for site lighting electrical requirements, including conduits, pole bases, pull boxes, etc.

GENERAL NOTES

POPEYE'S LOUISIANA KITCHEN
KANSAS CITY, CLAY COUNTY, MISSOURI
SITE ADDRESS: 9806 N. OAK TRAFFICWAY

PHILIPS ENGINEERING, INC.

1370 N. Winchester
Olathe, Kansas 66061
(913) 993-1815
Fax: (913) 993-1165
www.philipsengineering.com

PLANNING
ENGINEERING
IMPLEMENTATION

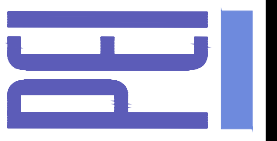
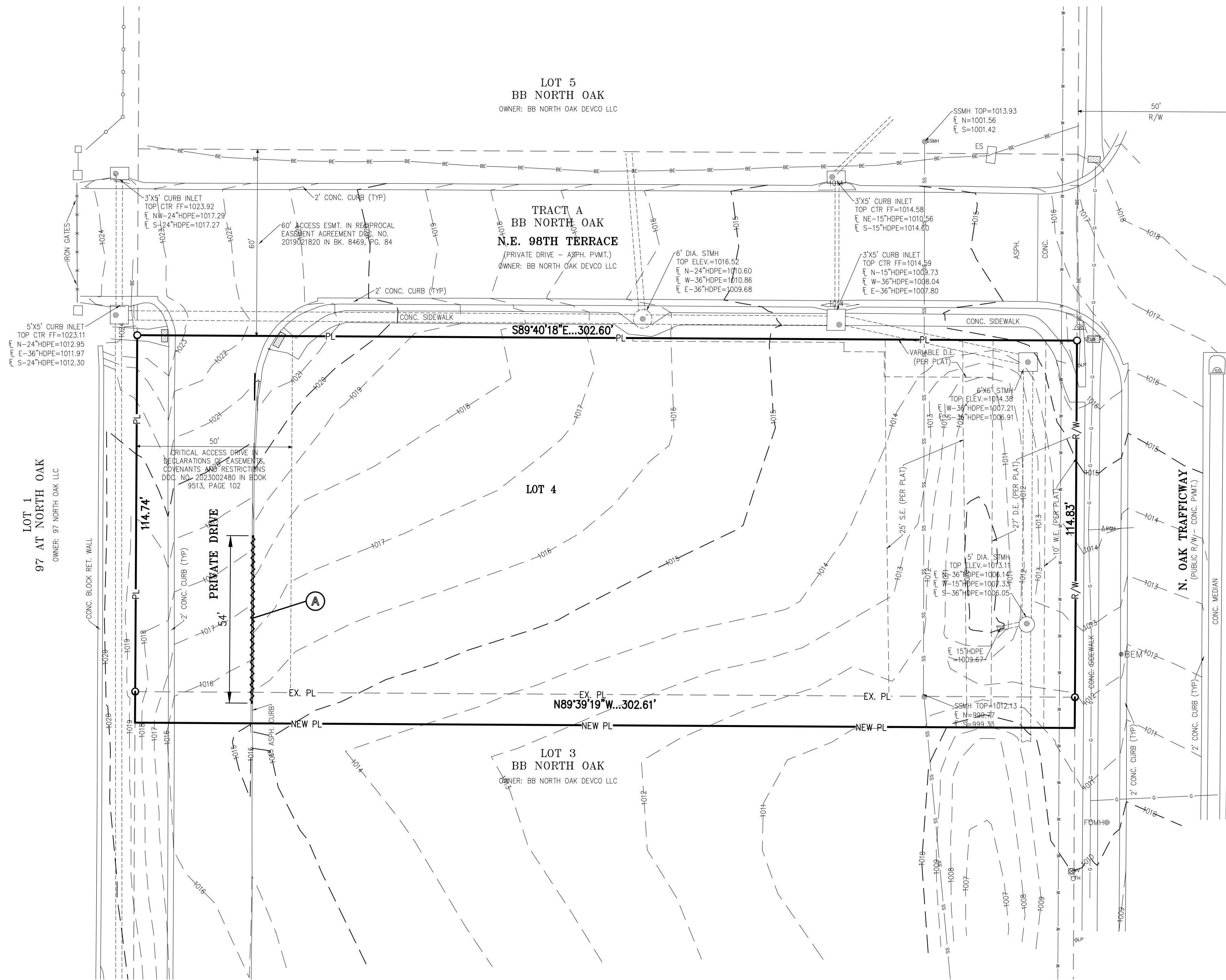

Table with columns: PROJECT NO., DATE, NO., DATE, REVISIONS, BY, APP. Includes project details like 230374, 10-18-2024, and revision notes.



Know what's below.
Call before you dig.

UTILITY NOTES:
VISUAL INDICATIONS OF UTILITIES ARE AS SHOWN.
UNDERGROUND LOCATIONS SHOWN, AS FURNISHED BY THEIR LESSORS, ARE APPROXIMATE AND SHOULD BE VERIFIED IN THE FIELD AT THE TIME OF CONSTRUCTION. FOR ACTUAL FIELD LOCATIONS OF UNDERGROUND UTILITIES CALL 811.



DEMOLITION KEY NOTES:

- (A) REMOVE EXISTING PRIVATE CURB AND GUTTER.

LEGEND

- PL PROPERTY LINE
- LL LOT LINE
- R/W RIGHT-OF-WAY
- REMOVE EXISTING CURB & GUTTER
- EXISTING BUILDING TO BE REMOVED
- EXISTING ASPHALT PAVEMENT TO BE REMOVED
- EXISTING CONCRETE PAVEMENT/SIDEWALK TO BE REMOVED
- EXISTING GRAVEL TO BE REMOVED
- EXISTING TREE TO REMAIN
- REMOVE TREE
- BT EXISTING BURIED TELEPHONE
- CATV EXISTING CABLE TELEVISION LINE
- FO EXISTING FIBER OPTIC LINE
- W EXISTING WATER LINE
- G EXISTING GAS LINE
- BE EXISTING BURIED ELECTRIC
- CHP EXISTING OVERHEAD POWER LINE
- SS EXISTING SANITARY SEWER
- EXISTING STORM SEWER
- EXISTING FIRE HYDRANT
- LP EXISTING LIGHT POLE
- EXISTING CHAIN LINK FENCE

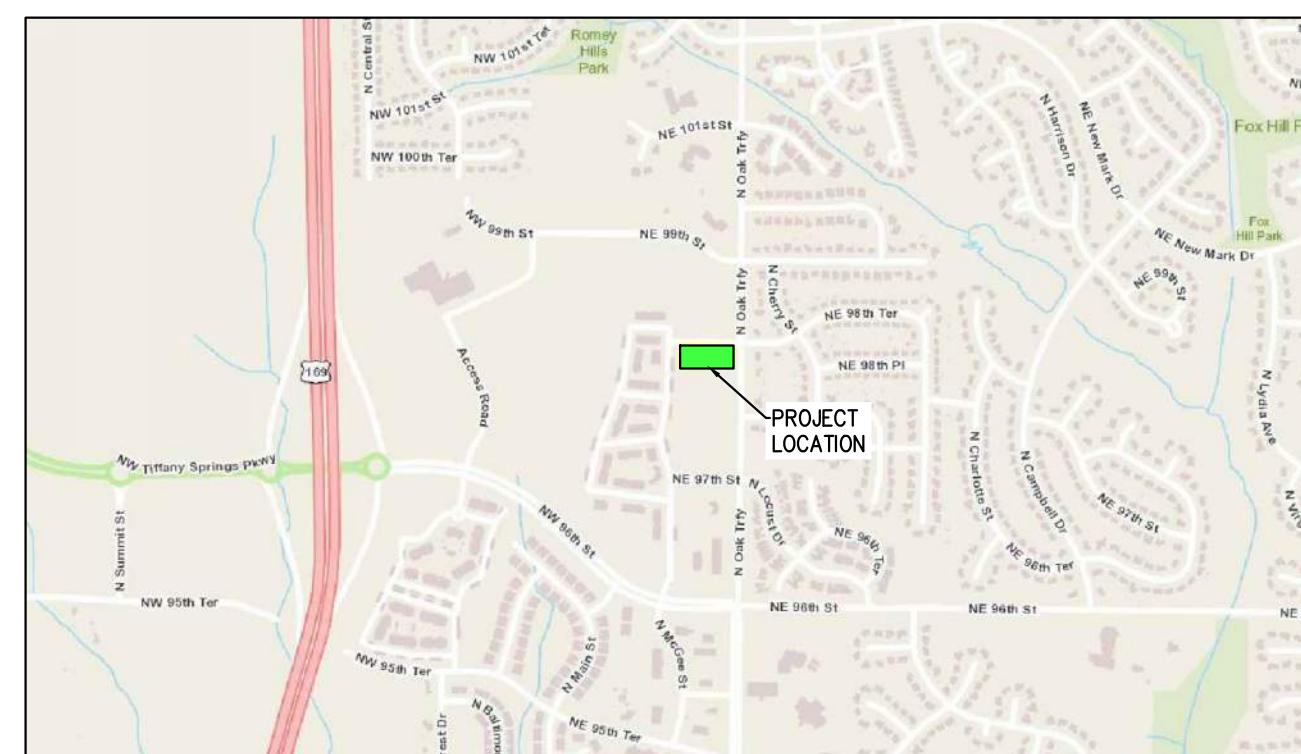

VICINITY MAP
NOT TO SCALE

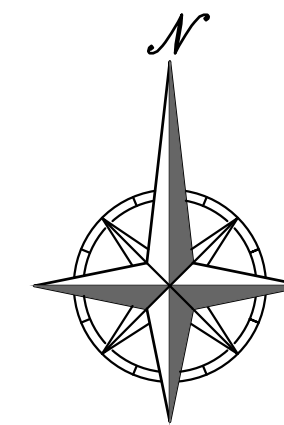

SCALE: 1"=20'
0' 20' 40'

PHELPS ENGINEERING, INC.
1370 N. Winchester
Olathe, Kansas 66061
(913) 993-1155
Fax: (913) 993-1165
www.phelpsengineering.com



DEMOLITION PLAN
POPEYE'S LOUISIANA KITCHEN
KANSAS CITY, CLAY COUNTY, MISSOURI
SITE ADDRESS: 9806 N. OAK TRAFFICWAY

PROJECT NO.	No.	Date	Revisions:	By	App.
230374	1.	10-18-2024	REVISED PER STAFF COMMENTS	AEB	DAF
DATE: 09-29-2024	DRAWN: AEB	CHECKED: DAF	APPROVED: DAF		
CORPORATE AUTHORIZATION					
LAND SURVEYING - LS-82					
ENGINEERING - E-361					
CERTIFICATE OF AUTHORIZATION					
LAND SURVEYING: 200701028					
ENGINEERING: 200700038					

SHEET
C002

V:\PHELPS-SERVER\Projects\1440374\Drawings\Permit Plans\SITE.dwg Layout1 Oct 20, 2024 - 8:35pm Daniel Fim

LOT 1
97 AT NORTH OAK
OWNER: 97 NORTH OAK LLC

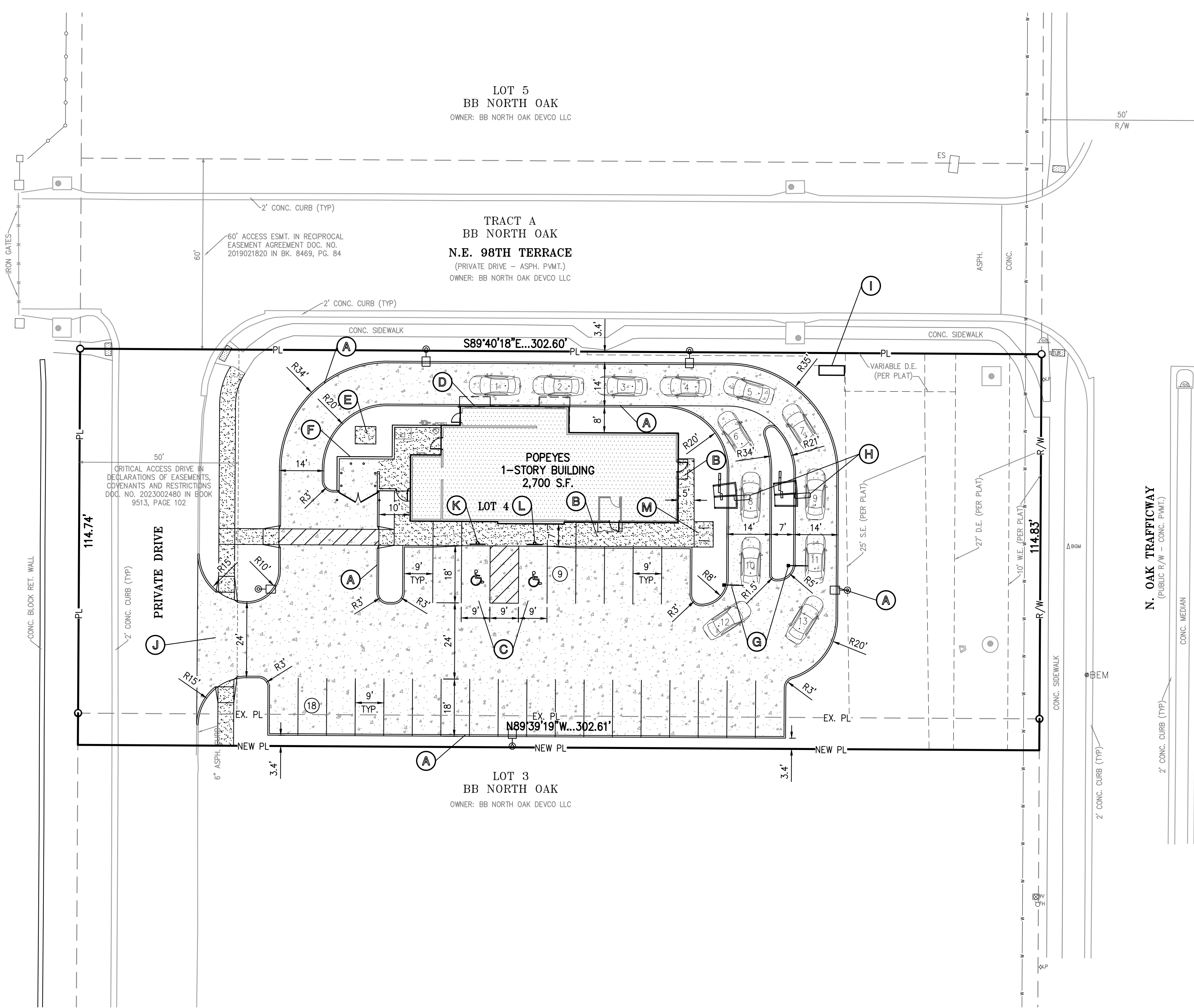

SITE DATA	Existing	Proposed	Deviation Requested?	Approved
Zoning	MPD	MPD	-	-
Gross Land Area	-	-	-	-
in square feet	34,735 SF	37,745 SF	-	-
in acres	0.80 AC.	0.87 AC.	-	-
Right-of-way Dedication	-	-	-	-
in square feet	N/A	N/A	-	-
in acres	N/A	N/A	-	-
Net Land Area	-	-	-	-
in square feet	34,735 SF	37,745 SF	-	-
in acres	0.80 AC.	0.87 AC.	-	-
Building Area (sq. ft.)	-	2,700 S.F.	-	-
Floor Area Ratio	-	0.0715	-	-
Residential Use Info	-	-	-	-
Total Dwelling Units	-	-	-	-
Detached House	-	-	-	-
Zero lot line House	-	-	-	-
Cottage House	-	-	-	-
Semi-attached House	-	-	-	-
Townhouse	-	-	-	-
Two-unit House	-	-	-	-
Multi-unit House	-	-	-	-
Colonnade	-	-	-	-
Multiplex	-	-	-	-
Multi-unit Building	-	-	-	-
Total Lots	-	-	-	-
Residential	-	-	-	-
Public/Civic	-	-	-	-
Commercial	1	1	-	-
Industrial	-	-	-	-
Other	-	-	-	-

BUILDING DATA	Required	Proposed	Deviation Requested?	Approved
Rear Setback	NONE	106'	-	-
Front Setback	20'	113'	-	-
Side Setback	NONE	18'	-	-
Side Setback (abutting street)	20'	N/A	-	-
Height	30'	19'	-	-

88-420 - PARKING	Vehicle Spaces		Bike Spaces		Alternatives Proposed? (See 88-420-16)
	Required	Proposed	Required	Proposed	
Proposed Use(s)					
List All Proposed Uses	27	27	3	4	
Total EATING AND DRINKING ESTABLISHMENTS					

88-425 - OTHER DEVELOPMENT STANDARDS	Method of Compliance
88-428 Fastland Dedication	NOT APPLICABLE
88-415 Stream Buffers	NOT APPLICABLE
88-430 Outdoor Lighting	PHOTOMETRIC PLAN TO MEET CODE
88-435 Outdoor Display, Storage and Work Areas	NOT APPLICABLE
88-445 Signs	MONUMENT AND BUILDING SIGNAGE TO MEET CODE
88-450 Pedestrian Standards	PEDESTRIAN STANDARDS TO MEET CODE

SITE KEY NOTES:

- (A) CONSTRUCT PRIVATE 6" CURB.
- (B) CONSTRUCT PRIVATE CONCRETE SIDEWALK.
- (C) CONSTRUCT ACCESSIBLE PARKING SPACE. INSTALL MARKINGS PER STANDARD DETAIL. INSTALL CONCRETE WHEEL STOPS.
- (D) PICK-UP WINDOW (RE. ARCHITECT PLANS).
- (E) PROPOSED TRANSFORMER PAD (RE. UTILITY PLAN).
- (F) INSTALL TRASH ENCLOSURE & EXTERIOR STORAGE ROOM (RE. ARCHITECT PLANS).
- (G) INSTALL CLEARANCE BAR (RE. ARCHITECT PLANS).
- (H) INSTALL MENU BOARD AND ORDER BOX (RE. ARCHITECT PLANS).
- (I) PROPOSED MONUMENT SIGN (RE. ARCHITECT PLANS).
- (J) CONSTRUCT PRIVATE CONCRETE ENTRANCE.
- (K) INSTALL VAN ACCESSIBLE PARKING SIGN (1).
- (L) INSTALL ACCESSIBLE PARKING SIGN (1).
- (M) INSTALL 2 BICYCLE RACKS FOR 4 BICYCLE SPACES. EACH SPACE SHALL BE A MINIMUM 2'X6'.

LEGEND

— PL —	PROPERTY LINE
— LL —	LOT LINE
— R/W —	RIGHT-OF-WAY
— 6" CURB —	6" CURB
— B/L —	BUILDING SETBACK LINE
— P/S —	PARKING SETBACK LINE
[Pattern]	PROPOSED BUILDING
[Pattern]	CONCRETE PAVEMENT
[Pattern]	CONCRETE SIDEWALK

LEGAL DESCRIPTION:

LOT 4, BB NORTH OAK, TOGETHER WITH THE NORTH 10 FT OF LOT 3, BB NORTH OAK, A SUBDIVISION IN KANSAS CITY, CLAY COUNTY, MISSOURI.

GROSS AREA = ±0.8685 ACRES / ±37,745 SQ.FT.

FLOOD NOTE:

THIS PROPERTY LIES WITHIN ZONE X, DEFINED AS AREAS DETERMINED TO BE OUTSIDE THE 0.2% ANNUAL CHANCE FLOODPLAIN, AS SHOWN ON THE FLOOD INSURANCE RATE MAP PREPARED BY THE FEDERAL EMERGENCY MANAGEMENT AGENCY FOR KANSAS CITY, COMMUNITY NO. 290173, CLAY COUNTY, MISSOURI, MAP NO. 29095C00846, AND DATED JANUARY 20, 2017.

ESTIMATED CONSTRUCTION SCHEDULE:

Commencement of Construction Date: March 2025
Completion of Construction Date: March 2026

BUILDING & LOT DATA

Site Area	37,745 S.F./0.87 Ac.
Zoning	MPD
Proposed Building No. of Stories	1 Story
Total Building S.F.	2,700 S.F.
Floor Area Ratio (FAR)	0.0715

PARKING SUMMARY

Parking Provided	
Standard Parking Provided	25 Spaces
Handicap Accessible Parking Spaces Provided	2 Spaces
Total Parking Provided	27 Spaces
Parking Required:	
10 Spaces For Every 1,000 S.F.	27 Spaces

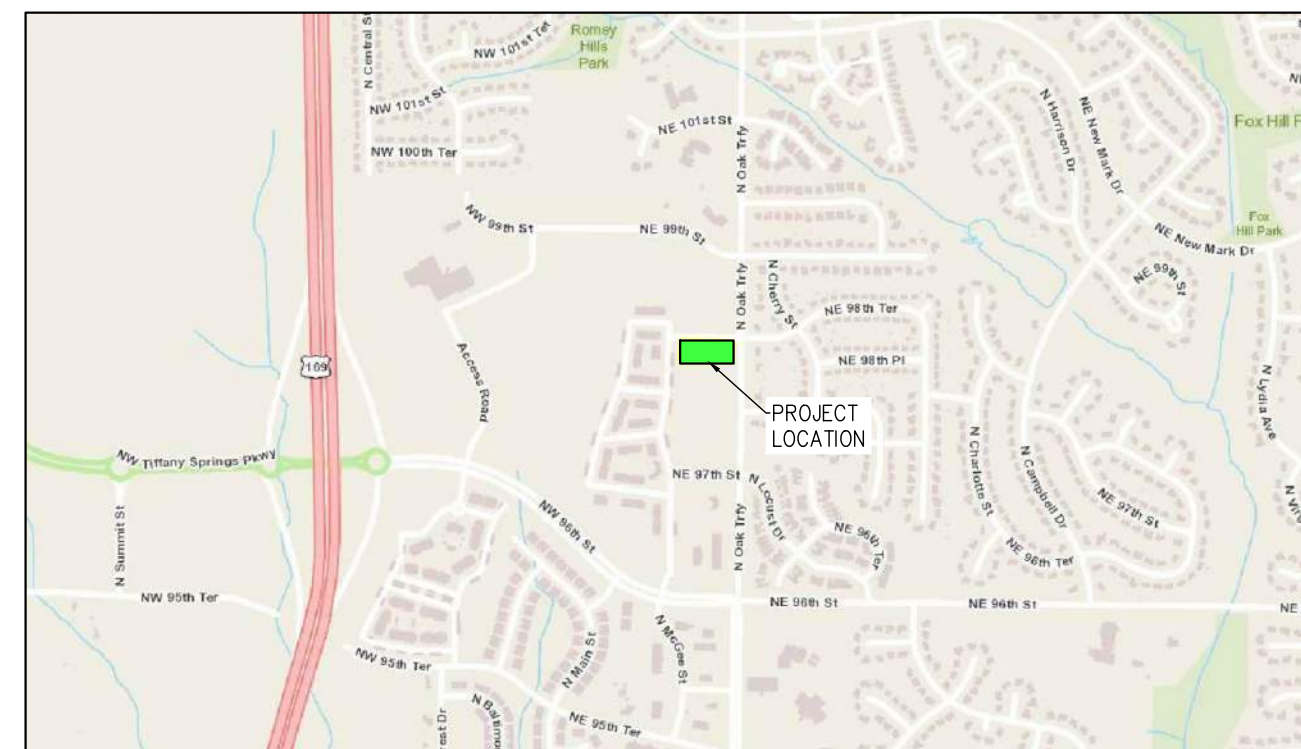

VICINITY MAP
NOT TO SCALE

OWNER:
BB NORTH OAK DEVCO, LLC
7121 W. 79TH STREET
OVERLAND PARK, KS 66204
CONTACTS: DOUG HENZLIK, JODY STRINGER
PHONE: 913-725-0406

DEVELOPER:
CSM GROUP
10190 KATY FREEWAY, SUITE 350
HOUSTON, TX 77043
CONTACTS: FELIX ZAMKOVSKY
PHONE: 713-907-2840



Know what's below.
Call before you dig.

PHELPS ENGINEERING, INC.
1270 N. Winchester
Olathe, Kansas 66061
(913) 993-1155
Fax (913) 993-1165
www.phelpsengineering.com

PLANNING
ENGINEERING
IMPLEMENTATION

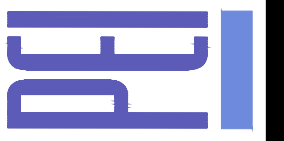

SITE PLAN
POPEYE'S LOUISIANA KITCHEN
KANSAS CITY, CLAY COUNTY, MISSOURI
SITE ADDRESS: 9806 N. OAK TRAFFICWAY

PROJECT NO.	Date	By	App.
230374	10-18-2024	AEB	DAF
1.			

SHEET
C100

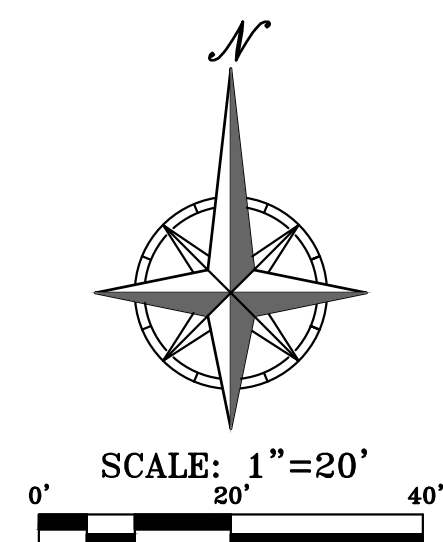

N.E. 98TH TERRACE

(PRIVATE DRIVE - ASPH./PWT.)

OWNER: BB NORTH OAK DEVCO LLC

6" DIA. STMH
TOP ELEV.=1016.52
N=24°HDPE=1010.60
W=36°HDPE=1010.86
E=36°HDPE=1009.68

3'x5' CURB INLET
TOP CIR FF=1014.59
N=24°HDPE=1009.73
W=36°HDPE=1008.04
E=36°HDPE=1007.80

6'x6' STMH
TOP ELEV.=1014.38
N=36°HDPE=1007.28
W=36°HDPE=1006.91

6" DIA. STMH
TOP ELEV.=1013.88
N=36°HDPE=1006.14
W=15°HDPE=1007.33
S=36°HDPE=1006.03

STMH TOP=1012.13
N=999.77
S=999.33

POPEYES
1-STORY BUILDING
2,700 S.F.
FFE=1017.00

LOT 3
BB NORTH OAK

OWNER: BB NORTH OAK DEVCO LLC

Earthwork Summary
Popeye's
10/16/2024

Raw Excavation	220 Cu. Yds.
In Place Compaction (+15%)	-902 Cu. Yds.
Pavement Adjustment	605 Cu. Yds. (assume 12" of additional excavation)
Building Adjustment	200 Cu. Yds. (assume 24" of additional excavation)
On Site Net	123 Cu. Yds.

* EARTHWORK COMPUTATIONS BY PHELPS ENGINEERING, INC. ARE PROVIDED FOR INFORMATIONAL PURPOSES ONLY AND SHALL BE VERIFIED BY CONTRACTORS BY THEIR CHOSEN METHOD PRIOR TO PLACING BID. ALL EARTHWORK SHALL BE CONSIDERED UNCLASSIFIED. 15% WAS ADDED INTO RAW FILL QUANTITY TO ACCOUNT FOR SHRINKAGE.

LEGEND

- PL PROPERTY LINE
 - LL LOT LINE
 - R/W RIGHT-OF-WAY
 - 6" CURB
 - EXISTING CONTOURS
 - PROPOSED CONTOURS
 - EXISTING STORM SEWER
 - PROPOSED STORM PIPE
- PROPOSED SPOT ELEVATION
- LG LIP OF GUTTER
 - TC TOP OF CURB
 - SW SIDEWALK
 - ME MATCH EXISTING
 - HP HIGH POINT
 - LP LOW POINT
 - P TOP OF PAVEMENT
 - TE TOP OF STRUCTURE
 - GR GROUND ELEVATION
 - BS BOTTOM OF STEPS
 - TS TOP OF STEPS
 - BW BOTTOM OF WALL
 - TW TOP OF WALL

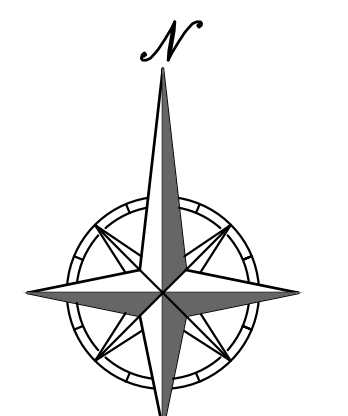

SCALE: 1"=10'

CRITICAL ACCESS DRIVE IN DECLARATIONS OF EASEMENTS, COVENANTS AND RESTRICTIONS DOC. NO. 2023002480 IN BOOK 8913, PAGE 102

PRIVATE DRIVE

PROJECT NO. 230374 DATE: 09-29-2024 DRAWN: AEB CHECKED: DAF APPROVED: DAF
 CORPORATE DATE OF AUTHORIZATION: 08-22-2024
 LAND SURVEYING - LS-82 ENGINEERING - E-36
 CREATION DATE OF AUTHORIZATION: 08-22-2024
 LAND SURVEYING: 200701028 ENGINEERING: 200300308



Know what's below.
Call before you dig.

PHELPS ENGINEERING, INC.
1270 N. Winchester
Olathe, Kansas 66061
(913) 993-1155
Fax: (913) 993-1165
www.phelpsengineering.com



GRADING PLAN
POPEYE'S LOUISIANA KITCHEN
KANSAS CITY, CLAY COUNTY, MISSOURI
SITE ADDRESS: 9806 N. OAK TRAFFICWAY

Revisions:	No.	Date	By	App.
REVISED PER STAFF COMMENTS	1.	10-18-2024	AEB	DAF

SHEET
C200

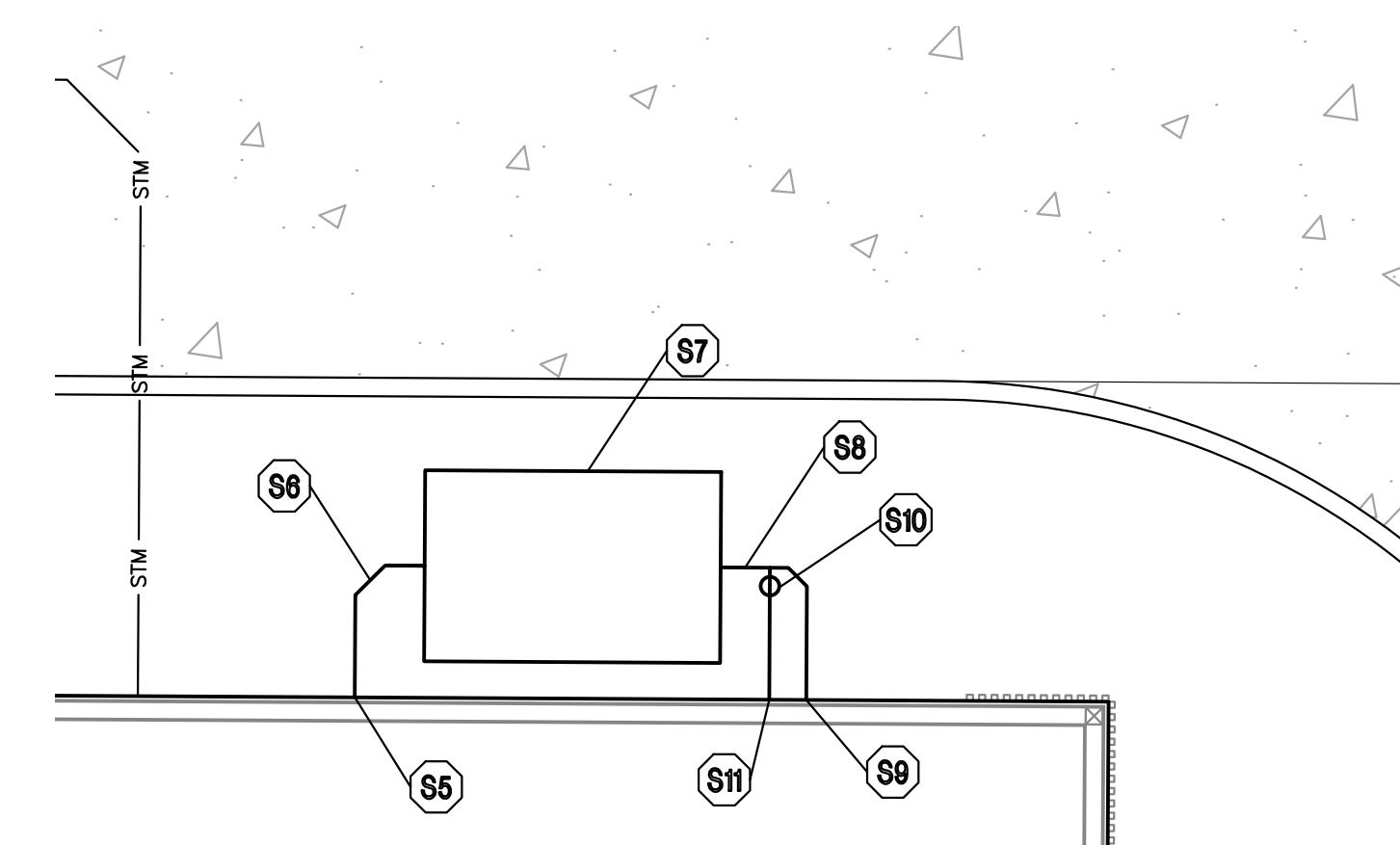
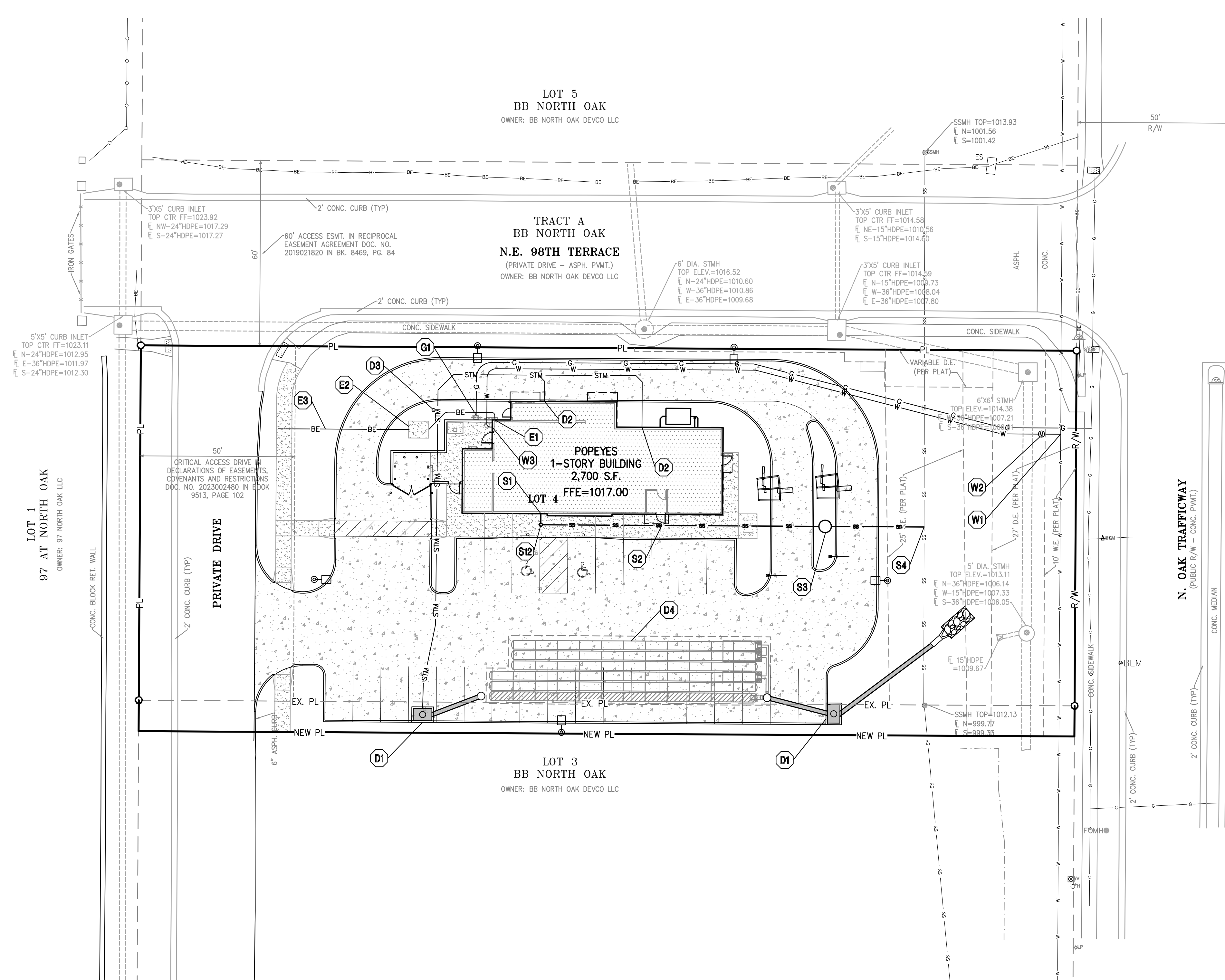

UTILITY KEY NOTES:

- (D1) INSTALL PRIVATE STORM SEWER (SEE SHEET C400).
- (D2) BUILDING INTERNAL ROOF DRAIN CONNECTION (RE: BUILDING PLANS).
- (D3) INSTALL 24" LANDSCAPE DRAIN W/ STANDARD GRATE.
- (D4) INSTALL 69 STORMTECH SC-310 CHAMBERS (SEE SHEETS C401 AND C402).
- (E1) ELECTRIC ENTRY INTO BUILDING. FOLLOW EVERY REQUIREMENTS (RE: BUILDING ELECTRIC PLAN).
- (E2) INSTALL CONCRETE TRANSFORMER PAD. CONTRACTOR TO VERIFY EXACT LOCATION & SIZE WITH EVERY PRIOR TO CONSTRUCTION. CONTRACTOR SHALL BE RESPONSIBLE FOR INSTALLATION OF CONCRETE PAD AND CONDUIT AS REQUIRED BY THE ELECTRIC COMPANY. CONTRACTOR SHALL COORDINATE SAID WORK WITH THE ELECTRIC COMPANY.
- (E3) INSTALL PRIMARY ELECTRICAL CONDUIT. FOLLOW EVERY WORKORDER AND SPECIFICATIONS FOR PRIMARY ELECTRICAL SERVICE. COORDINATE PRIMARY POWER ROUTING WITH EVERY.
- (G1) GAS ENTRY WITH GAS METER. CONTRACTOR SHALL COORDINATE WITH GAS COMPANY FOR INSTALLATION OF GAS METER. SIZE OF GAS MAIN SHALL BE AS DETERMINED BY UTILITY OR AS SHOWN ON BUILDING PLANS. CONTRACTOR IS RESPONSIBLE FOR COORDINATION WITH GAS COMPANY REGARDING THE SIZE AND INSTALLATION OF GAS SERVICE LINE.
- (S1) CONNECT TO BUILDING INTERIOR SANITARY SEWER PLUMBING. TRANSITION FROM 4" INTERIOR TO 6" EXTERIOR AT FOUNDATION WALL. (RE: MEP PLANS). FL=1017.00
- (S2) INSTALL 6" PVC (SDR-26) SANITARY SEWER SERVICE LINE (SDR-26) @ 1.0% MIN. SLOPE.
- (S3) INSTALL 4" DIAMETER SAMPLING MANHOLE (RE: KCMO STANDARD DETAIL WH-1). T.E.=1015.40 FL=1003.40 FL OUT=1003.40
- (S4) CONNECT TO EXISTING 8" PVC PUBLIC SANITARY SEWER MAIN W/ TEE CONNECTION. EX. 8" FL=1000.38 PROP. 6" FL=1000.54
- (S5) CONNECT TO BUILDING INTERIOR GREASE EXIT PLUMBING. (RE: MEP PLANS). FG=1017.00 FL 4"=1013.00
- (S6) INSTALL 5' L.F. OF 4" PVC (SDR-26) SANITARY SEWER SERVICE LINE @ 2.0% SLOPE MIN. SLOPE.
- (S7) INSTALL ZURN GMC 1500 UPC GREASE INTERCEPTOR (REFER TO MEP PLANS FOR DETAIL). TE=1016.40 FL 4" IN = 1012.90 FL 4" OUT = 1012.70
- (S8) INSTALL 6' L.F. OF 4" PVC (SDR-26) SANITARY SEWER SERVICE LINE @ 2.0% MIN. SLOPE.
- (S9) CONNECT TO BUILDING INTERIOR GREASE ENTRY PLUMBING. (RE: MEP PLANS). FG=1017.00 FL 4"=1012.58
- (S10) INSTALL 4" SANITARY SEWER TWO-WAY CLEAN OUT.
- (S11) CONNECT 2" VENT TO BUILDING INTERIOR PLUMBING. (RE: MEP PLANS).
- (S12) INSTALL 6" SANITARY SEWER CLEANOUT IN NON-PAVED AREA.
- (W1) CONTRACTOR TO COORDINATE CONNECTION TO EXISTING 8" PUBLIC WATER MAIN FOR NEW 2" TYPE K SOFT COPPER DOMESTIC WATER LINE WITH KCMO WSD. CONTRACTOR TO FOLLOW ALL KANSAS CITY WATER SERVICES DEPT. REQUIREMENTS. SEE CONNECTION DETAIL, THIS SHEET.
- (W2) CONTRACTOR TO PROVIDE AND INSTALL 2" WATER METER PIT PER KANSAS CITY, MISSOURI REQUIREMENTS. CONTRACTOR TO COORDINATE AND PAY ALL FEES. ALL LABOR AND MATERIALS SHALL BE PROVIDED AND INSTALLED BY THE CONTRACTOR'S PLUMBER IN ACCORDANCE WITH KANSAS CITY WATER SERVICES DEPT. REQUIREMENTS. SEE NOTES 13, 14, AND 15, SHEET C001, FOR MATERIAL AND COVER REQUIREMENTS.
- (W3) 2" DOMESTIC WATERLINE ENTRY TO BUILDING. CONTRACTOR SHALL BE RESPONSIBLE FOR INSTALLING ANY APPURTENANCES ON THE DOMESTIC LINE SUCH AS BACKFLOW PREVENTION DEVICES, GATE VALVES, REDUCERS, BENDS, TEES, FLOOR DRAINS, ETC (RE: BUILDING PLANS), WHICH MAY BE REQUIRED. CONTRACTOR TO COORDINATE WITH KCMO WSD.

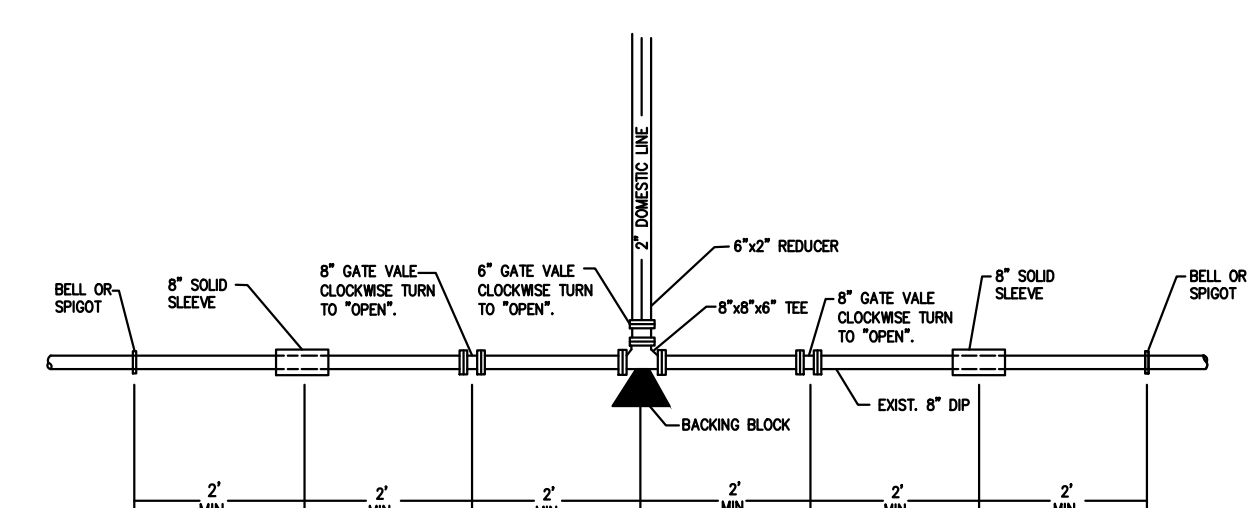

PERMANENT WATER CONNECTION DETAIL
NOT TO SCALE

LEGEND

PL	PROPERTY LINE
LL	LOT LINE
R/W	RIGHT-OF-WAY
CATV	EXISTING CABLE TELEVISION LINE
FO	EXISTING FIBER OPTIC LINE
G	EXISTING GAS LINE
BE	EXISTING BURIED ELECTRIC LINE
OHP	EXISTING OVERHEAD POWER LINE
OHT	EXISTING OVERHEAD TELEPHONE LINE
SS	EXISTING SANITARY SEWER LINE
24"HDPE	EXISTING STORM SEWER LINE (& SIZE)
BT	EXISTING BURIED TELEPHONE LINE
W-6"	EXISTING WATER LINE (& SIZE)
F-6"	PROPOSED FIRE LINE (& SIZE)
ST-6"	PROPOSED ROOF DRAIN (& SIZE)
PL	PROPOSED PROPERTY LINE
LL	PROPOSED LOT LINE
R/W	PROPOSED RIGHT-OF-WAY
CATV	PROPOSED CABLE TELEVISION LINE
FO	PROPOSED FIBER OPTIC LINE
G	PROPOSED GAS LINE
BE	PROPOSED BURIED ELECTRIC LINE
SS	PROPOSED SANITARY SEWER LINE
OHP	PROPOSED OVERHEAD POWER LINE
24"HDPE	PROPOSED STORM SEWER LINE (& SIZE)
BT	PROPOSED BURIED TELEPHONE LINE
W-6"	PROPOSED WATER LINE (& SIZE)
F-6"	PROPOSED FIRE LINE (& SIZE)
ST-6"	PROPOSED ROOF DRAIN (& SIZE)

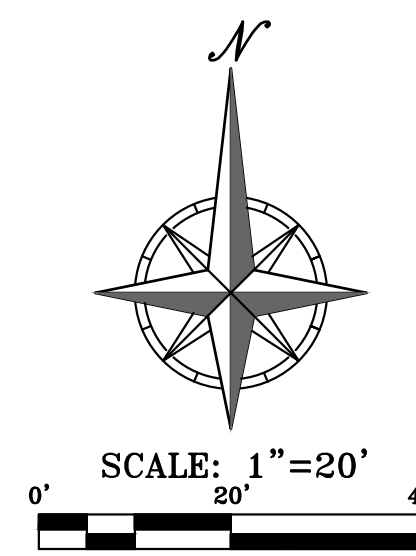

UTILITY COMPANIES:

<p>SPIRE ENERGY (816) 472-3434 BEVERLY PASSANTINO 7500 E. 35TH TERRACE KANSAS CITY, MO. 64129 EMAIL: beverly.passantino@spireenergy.com</p>	<p>CITY OF KANSAS CITY (816) 513-2627 PUBLIC WORKS DEPARTMENT 414 E. 12TH STREET KANSAS CITY, MO. 64106</p>
<p>EVERGY (816) 420-4721 MELISSA FELTES 8325 N. PLATTE PURCHASE DRIVE KANSAS CITY, MO. 64118 E-MAIL: Melissa.Feltes@kcpl.com</p>	<p>CITY OF KANSAS CITY (GENERAL NUMBER) (816) 513-1313 CARLA HASKINS (WATER) (816) 513-2133 EMAIL: carla.haskins@kcmo.org AMY BUNNELL (LAND DEVELOPMENT DIVISION) (816) 513-2552 EMAIL: amy.bunnell@kcmo.org 4800 E. 63RD STREET KANSAS CITY, MO. 64130</p>
<p>AT&T (816) 734-8700 JILL SCHROEDER 9556 N. MCGEE COURT KANSAS CITY, MO 64155 EMAIL: jpb311@att.com</p>	<p>TIME WARNER CABLE (816) 358-8833 15 NW BARRY ROAD KANSAS CITY, MO. 64155</p>

UTILITY NOTES:
VISUAL INDICATIONS OF UTILITIES ARE AS SHOWN. UNDERGROUND LOCATIONS SHOWN, AS FURNISHED BY THEIR LESSORS, ARE APPROXIMATE AND SHOULD BE VERIFIED IN THE FIELD AT THE TIME OF CONSTRUCTION. FOR ACTUAL FIELD LOCATIONS OF UNDERGROUND UTILITIES CALL 811.



PHILIPS ENGINEERING, INC.
1370 N. Winchester
Olathe, Kansas 66061
(913) 993-1155
Fax (913) 993-1165
www.philipsengineering.com

**PLANNING
ENGINEERING
IMPLEMENTATION**

UTILITY PLAN
POPEYE'S LOUISIANA KITCHEN
KANSAS CITY, CLAY COUNTY, MISSOURI
SITE ADDRESS: 9806 N. OAK TRAFFICWAY

Revisions:	By	App.	Date	Comments
1.			10-18-2024	REVISED PER STAFF COMMENTS

PROJECT NO. 230374
DATE 09-29-2024
DRAWN/AEB
CHECKED/DAF
APPROVED/DAF
DATE OF AUTHORIZATION
LAND SURVEYING - LS-82
ENGINEERING - E-361
CREATED DATE OF AUTHORIZATION
LAND SURVEYING-200701028
ENGINEERING-200303038

SHEET
C300

\\PHILIPS-SERVER\Projects\230374\Utility\Permit Plans\UTILITY.dwg Layout1: Oct 20, 2024 - 8:31pm Donnie Finn

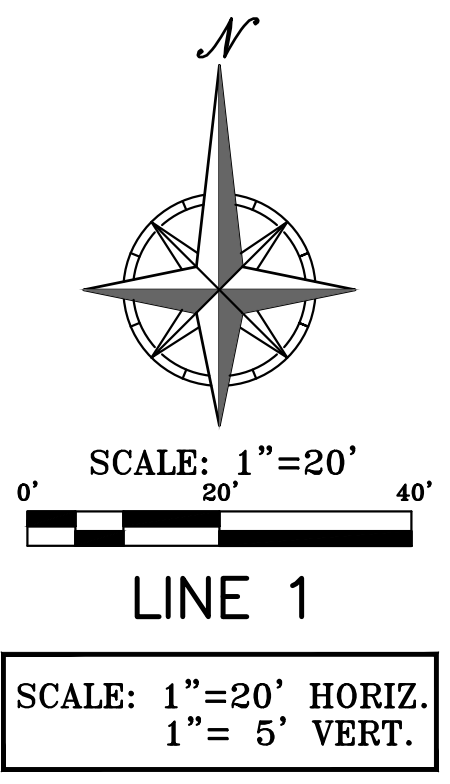
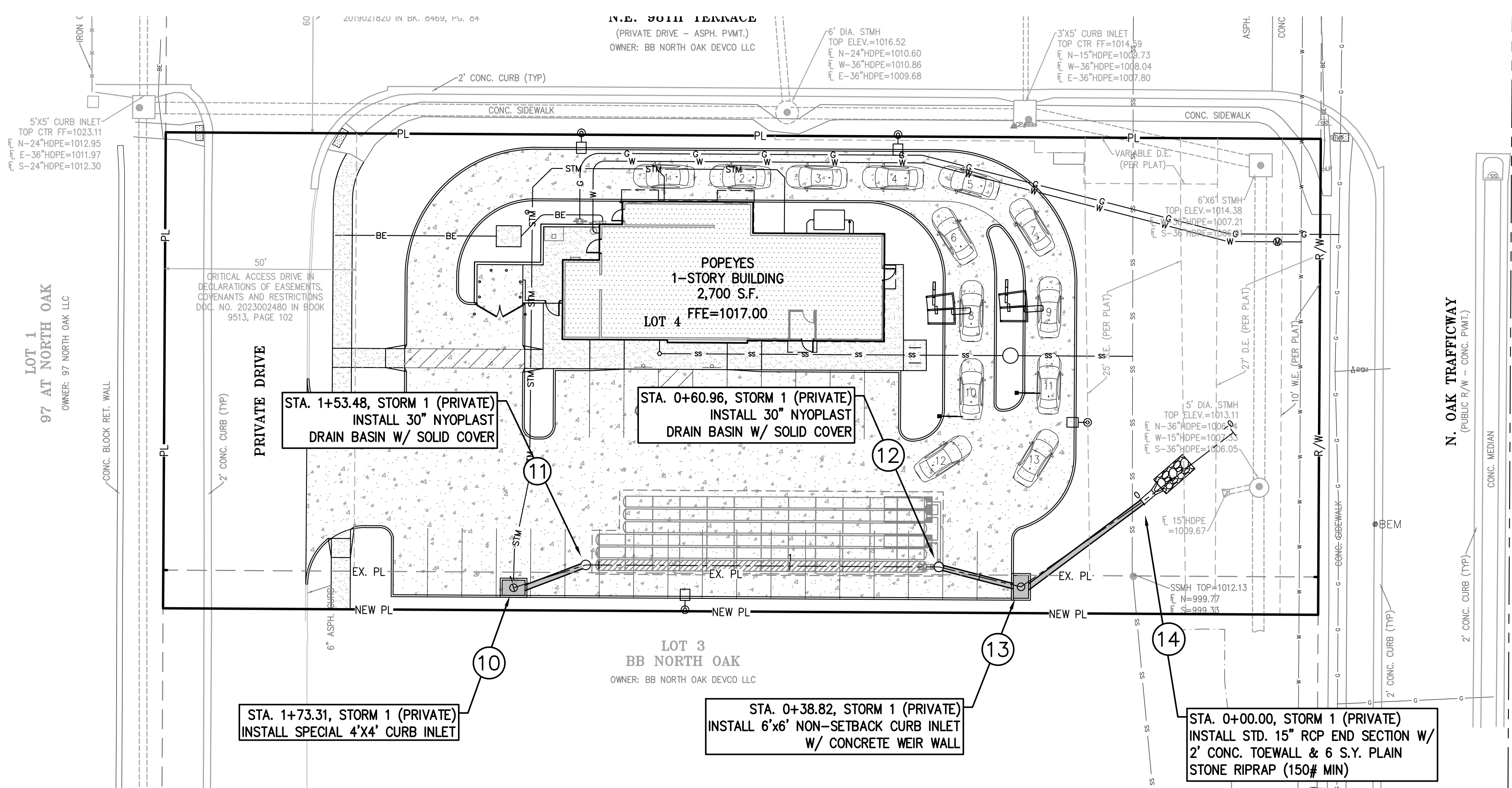

STORM 1 (PRIVATE)

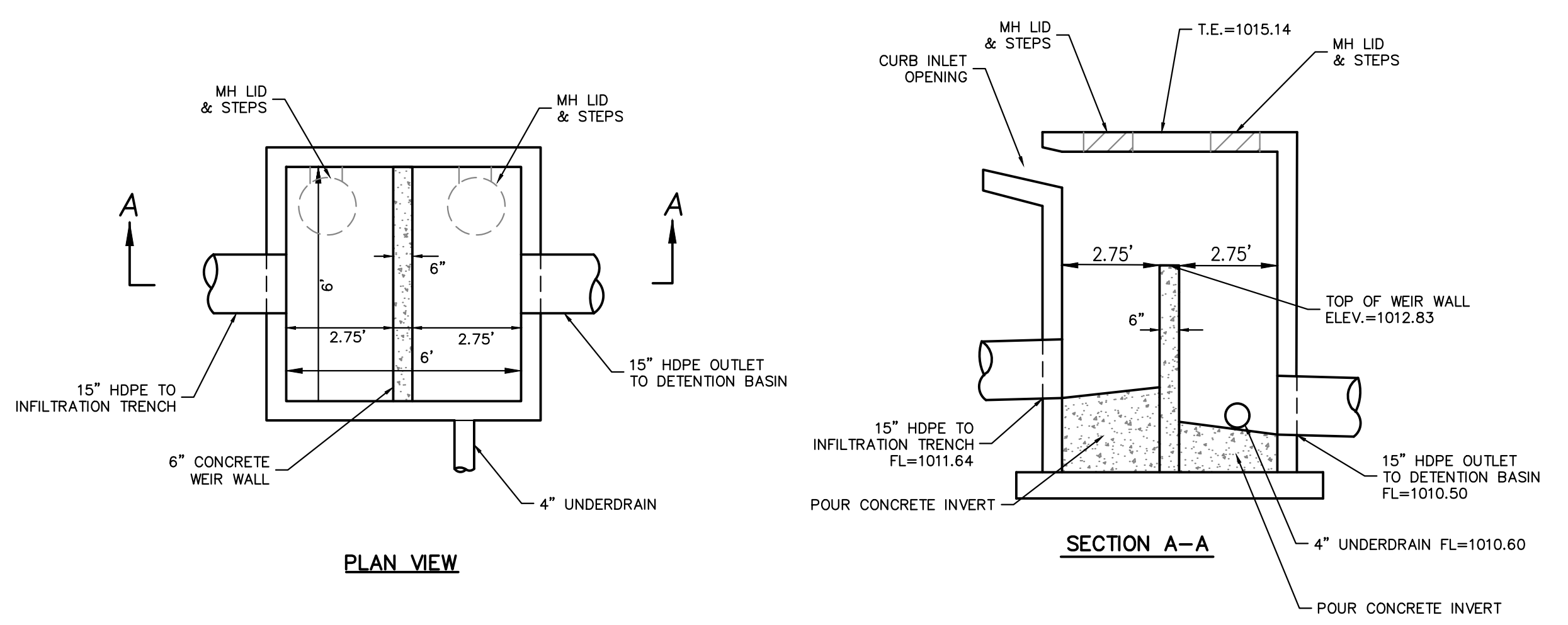
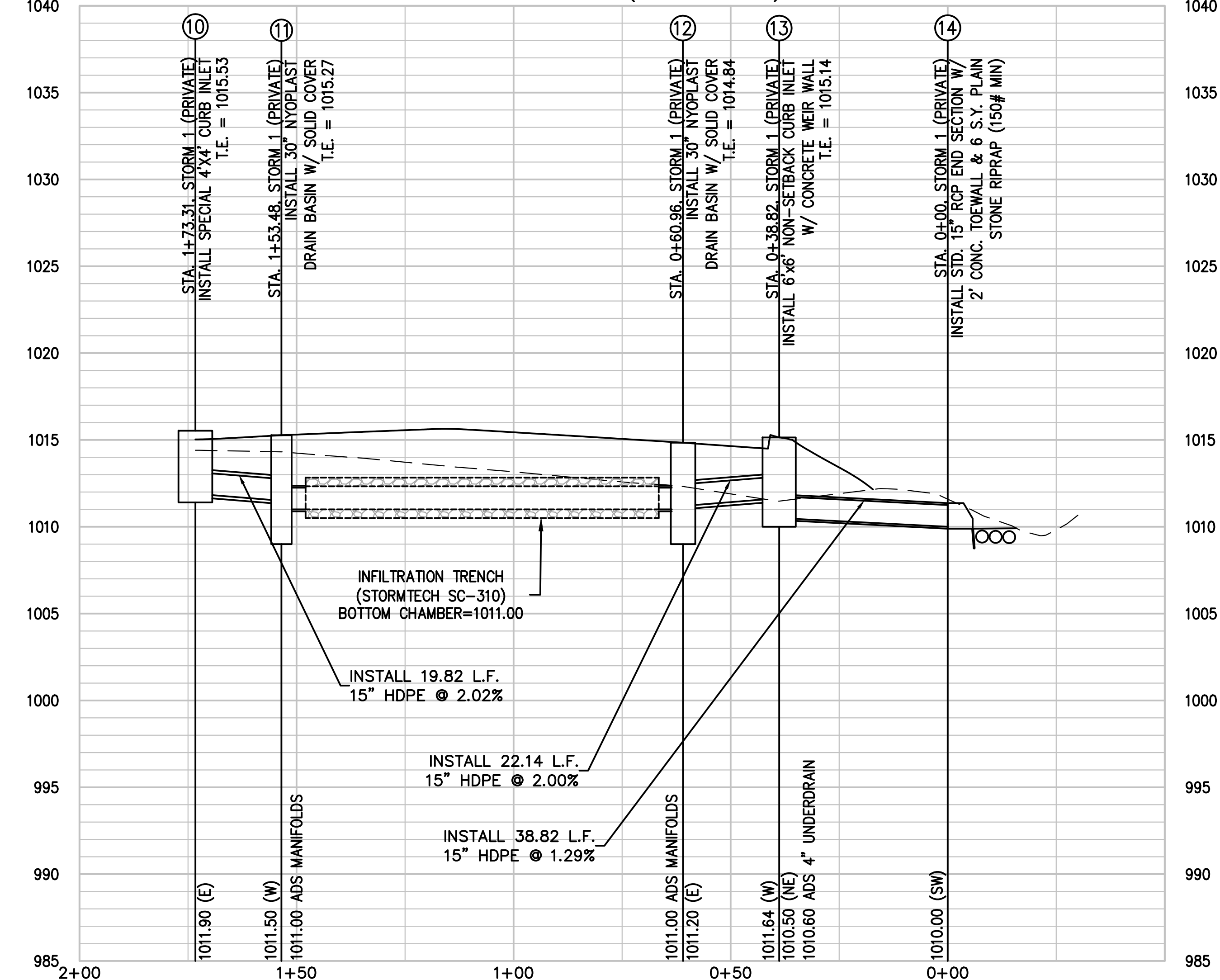

STRUCTURE #13
6'x6' OUTLET CONTROL STRUCTURE

PHELPS ENGINEERING, INC.
1270 N. Winchester
Olathe, Kansas 66061
(913) 993-1155
Fax (913) 993-1165
www.phelpsengineering.com

**PLANNING
ENGINEERING
IMPLEMENTATION**

STORM SEWER PLAN & PROFILE
POPEYE'S LOUISIANA KITCHEN
KANSAS CITY, CLAY COUNTY, MISSOURI
SITE ADDRESS: 9806 N. OAK TRAFFICWAY

PROJECT NO.	DATE	BY	APP.
230374	09-29-2024	DAW/AEB	AEB/DAF
1.	10-18-2024	DAW/AEB	AEB/DAF

No.	Date	Revisions:
1.	10-18-2024	REVISED PER STAFF COMMENTS

SHEET
C400

\\PHELPS-SERVER\Projects\1\440374\Drawings\Storm\Storm.dwg Layout:1 Oct 20, 2024 8:31pm Daniel Finn

PROPOSED LAYOUT		CONCEPTUAL ELEVATIONS:		PART TYPE		ITEM ON LAYOUT		DESCRIPTION		INVERT ABOVE BASE OF CHAMBER	
89	STORMTECH SC-310 CHAMBERS	MAXIMUM ALLOWABLE GRADE (TOP OF PAVEMENT UNPAVED)	3.82	A	12" BOTTOM PREFABRICATED EZ END CAP PART# SC310ECCZ / TYP OF ALL 12" BOTTOM CONNECTIONS AND ISOLATOR PLUS ROWS	0.90"					
12	STORMTECH SC-310 END CAPS	MINIMUM ALLOWABLE GRADE (UNPAVED WITH TRAFFIC)	3.33	B	INSTALL FLAMP ON 12" ACCESS PIPE / PART# SC31012RAMP						
6	STONE ABOVE (6")	MINIMUM ALLOWABLE GRADE (UNPAVED NO TRAFFIC)	3.33	C	8" x 8" TOP MANIFOLD, 90° DED FITTINGS	3.50"					
6	STONE BELOW (6")	MINIMUM ALLOWABLE GRADE (TOP OF RIGID CONCRETE PAVEMENT)	3.33	D	8" BOTTOM CONNECTION	0.60"					
40	STONE VOID	MINIMUM ALLOWABLE GRADE (BASE OF FLEXIBLE PAVEMENT)	2.33	E	NYLOPLAST (INLET W/ ISO PLUS ROW)					2.3 CFS IN	
2437	INSTALLED SYSTEM VOLUME (CF)	TOP OF STONE	1.25	F	30" DIAMETER (DESIGN BY ENGINEER)						0.7 CFS OUT
	PERIMETER STONE INCLUDED (COVER STONE INCLUDED)	TOP OF SC-310 CHAMBER	1.25	G	ADS N-12 DUAL WALL PERFORATED HDPE UNDERDRAIN						
1854	SYSTEM AREA (SF)	12" ISOLATOR ROW PLUS INVERT	0.33								
228.9	SYSTEM PERIMETER (ft)	8" BOTTOM CONNECTION INVERT	0.33								
		SC-310 CHAMBER	0.33								
		UNDERDRAIN INVERT	0.33								
		BOTTOM OF STONE	0.00								

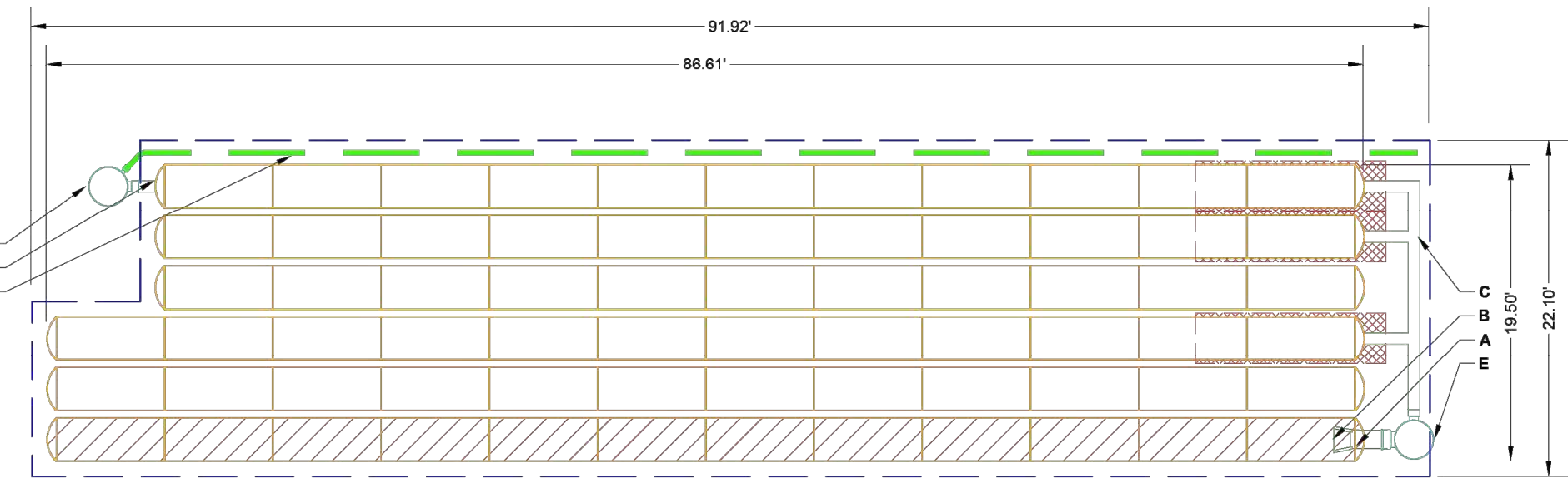

- ISOLATOR ROW PLUS (SEE DETAIL)
- PLACE MINIMUM 12.00' OF ADSRL5625 WOVEN GEOTEXTILE OVER BEDDING STONE AND UNDERNEATH CHAMBER FEET FOR SCOUR PROTECTION AT ALL CHAMBER INLET ROWS
- BED LIMITS

NOTES:
 1. THE SITE DESIGN ENGINEER MUST REVIEW ELEVATIONS AND IF NECESSARY ADJUST GRADING TO ENSURE THE CHAMBER COVER REQUIREMENTS ARE MET.
 2. NOT FOR CONSTRUCTION: THIS LAYOUT IS FOR DIMENSIONAL PURPOSES ONLY TO PROVE CONCEPT & THE REQUIRED STORAGE VOLUME CAN BE ACHIEVED ON SITE.

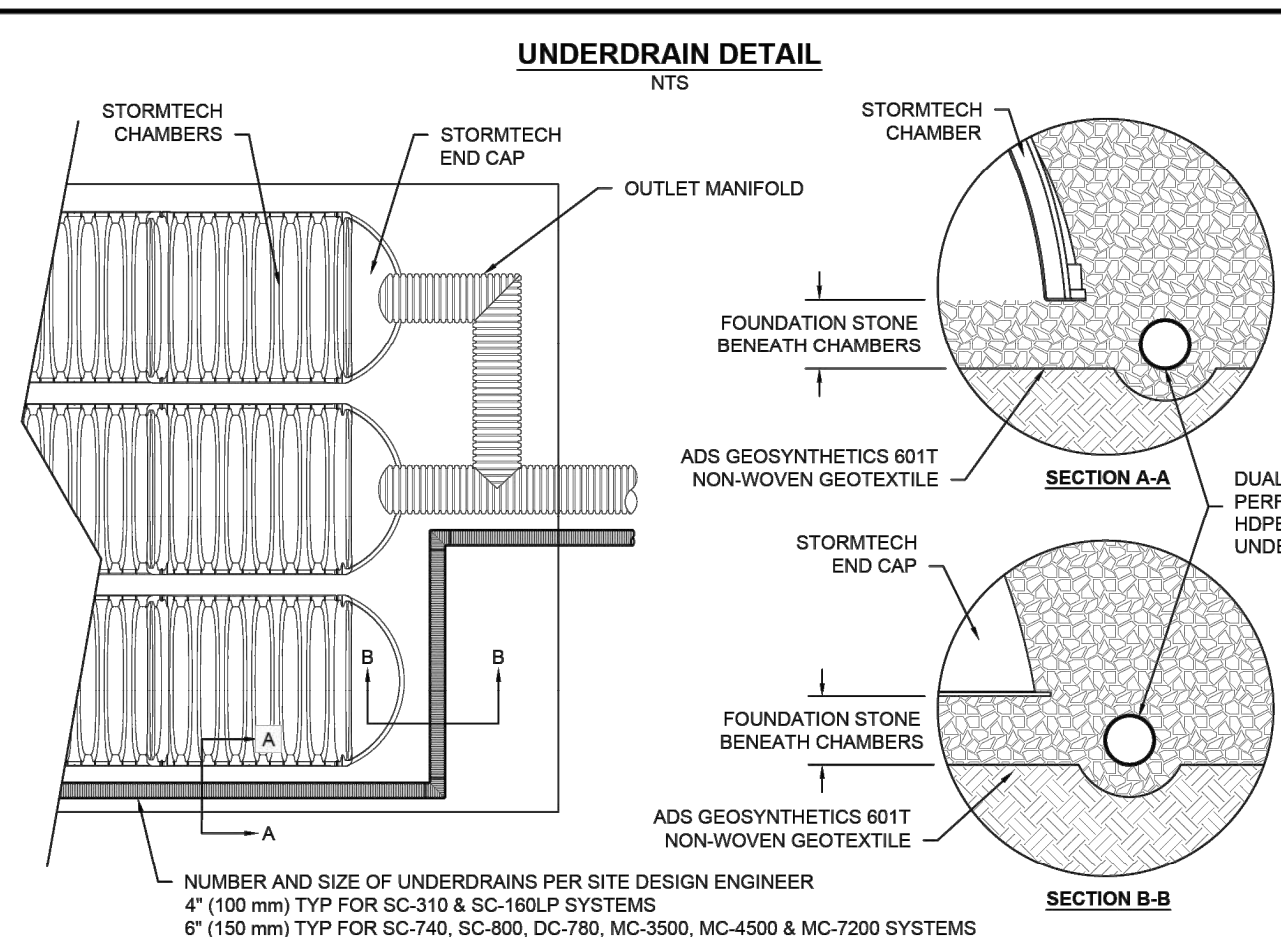

4 UNDERDRAIN DETAIL

SPACE INTENTIONALLY LEFT BLANK

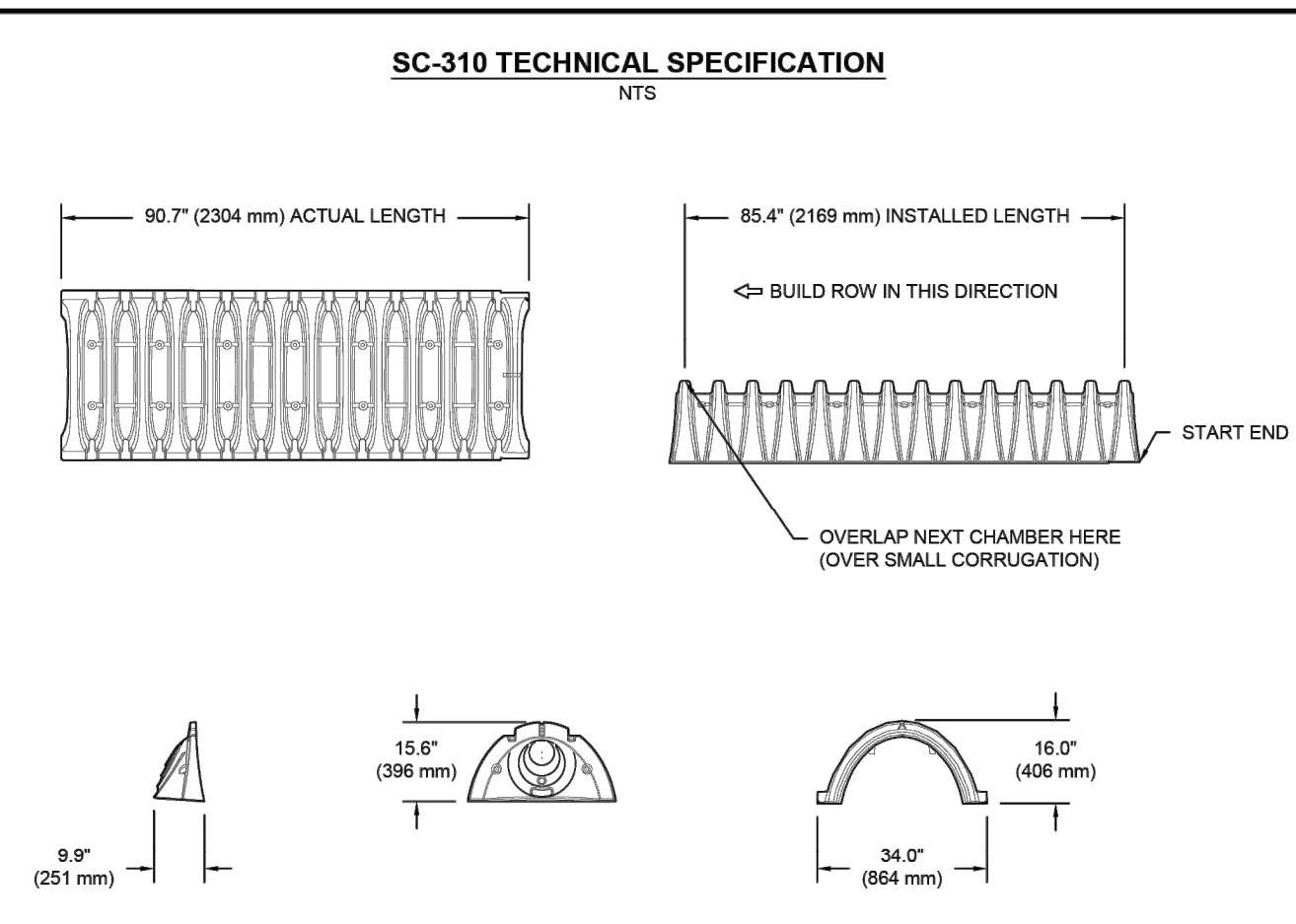

2 SC-310 TECHNICAL SPECIFICATION

NOMINAL CHAMBER SPECIFICATIONS	34.0" X 16.0" X 85.4"	(864 mm X 406 mm X 2169 mm)
CHAMBER STORAGE	14.7 CUBIC FEET (0.42 m ³)	
MINIMUM INSTALLED STORAGE*	31.0 CUBIC FEET (0.88 m ³)	
WEIGHT	35.0 lbs. (16.8 kg)	

PART #	STUB	A	B	C
SC310PE06T / SC310PE06TPC	6" (150 mm)	9.6" (244 mm)	5.8" (147 mm)	---
SC310PE08B / SC310PE08BPC	8" (200 mm)	11.9" (302 mm)	3.5" (89 mm)	0.5" (13 mm)
SC310PE10T / SC310PE10TPC	10" (250 mm)	12.7" (323 mm)	1.4" (36 mm)	---
SC310PE12B / SC310PE12BPC	12" (300 mm)	13.5" (343 mm)	---	0.9" (23 mm)

ALL STUBS, EXCEPT FOR THE SC310ECCZ ARE PLACED AT BOTTOM OF END CAP SUCH THAT THE OUTSIDE DIAMETER OF THE STUB IS FLUSH WITH THE BOTTOM OF THE END CAP. FOR ADDITIONAL INFORMATION CONTACT STORMTECH AT 1-800-821-8710.
 * FOR THE SC310ECCZ THE 12" (300 mm) STUB LIES BELOW THE BOTTOM OF THE END CAP APPROXIMATELY 0.25" (6 mm). BACKFILL MATERIAL SHOULD BE REMOVED FROM BELOW THE N-12 STUB SO THAT THE FITTING SITS LEVEL.
 NOTE: ALL DIMENSIONS ARE NOMINAL.

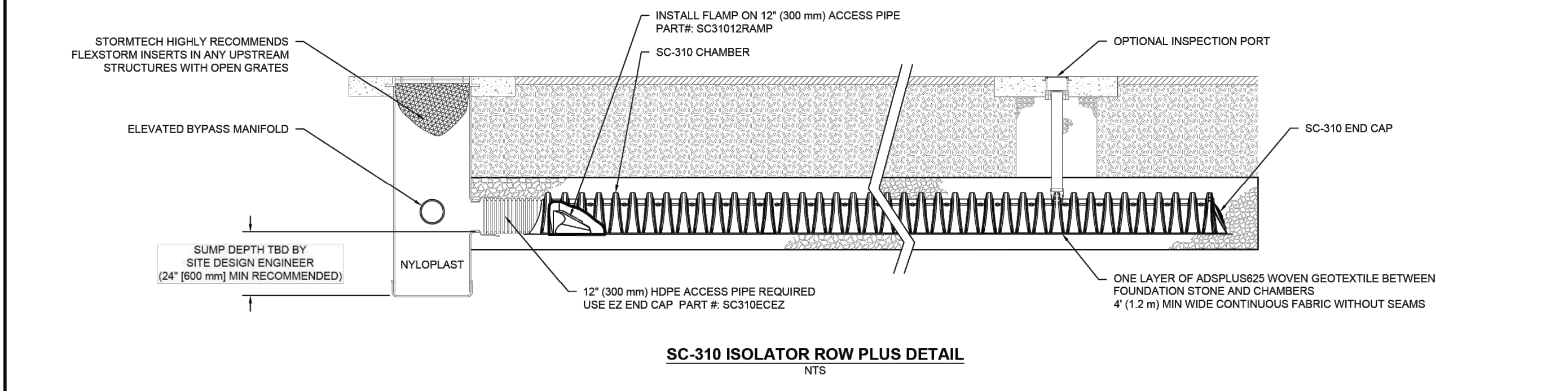

3 SC-310 ISOLATOR ROW PLUS DETAIL

- INSPECTION & MAINTENANCE**
- STEP 1) INSPECT ISOLATOR ROW PLUS FOR SEDIMENT
- INSPECTION PORTS (IF PRESENT)
 - REMOVE/OPEN LID ON NYLOPLAST INLINE DRAIN
 - REMOVE AND CLEAN FLEXSTORM FILTER IF INSTALLED
 - USING A FLASHLIGHT AND STADIA ROD, MEASURE DEPTH OF SEDIMENT AND RECORD ON MAINTENANCE LOG
 - LOWER A CAMERA INTO ISOLATOR ROW PLUS FOR VISUAL INSPECTION OF SEDIMENT LEVELS (OPTIONAL)
 - IF SEDIMENT IS AT, OR ABOVE, 3" (80 mm) PROCEED TO STEP 2. IF NOT, PROCEED TO STEP 3.
 - ALL ISOLATOR ROW PLUS
 - REMOVE COVER FROM STRUCTURE AT UPSTREAM END OF ISOLATOR ROW PLUS
 - USING A FLASHLIGHT, INSPECT DOWN THE ISOLATOR ROW PLUS THROUGH OUTLET PIPE
 - MIRRORS ON POLES OR CAMERAS MAY BE USED TO AVOID A CONFINED SPACE ENTRY
 - FOLLOW OSHA REGULATIONS FOR CONFINED SPACE ENTRY IF ENTERING MANHOLE
 - IF SEDIMENT IS AT, OR ABOVE, 3" (80 mm) PROCEED TO STEP 2. IF NOT, PROCEED TO STEP 3.
- STEP 2) CLEAN OUT ISOLATOR ROW PLUS USING THE JETVAC PROCESS
- A FIXED CULVERT CLEANING NOZZLE WITH REAR FACING SPREAD OF 45° (1.1 m) OR MORE IS PREFERRED
 - APPLY MULTIPLE PASSES OF JETVAC UNTIL BACKFLUSH WATER IS CLEAN
 - VACUUM STRUCTURE SUMP AS REQUIRED
- STEP 3) REPLACE ALL COVERS, GRATES, FILTERS, AND LIDS; RECORD OBSERVATIONS AND ACTIONS.
- STEP 4) INSPECT AND CLEAN BASINS AND MANHOLES UPSTREAM OF THE STORMTECH SYSTEM.

- NOTES:**
- INSPECT EVERY 6 MONTHS DURING THE FIRST YEAR OF OPERATION. ADJUST THE INSPECTION INTERVAL BASED ON PREVIOUS OBSERVATIONS OF SEDIMENT ACCUMULATION AND HIGH WATER ELEVATIONS.
 - CONDUCT JETTING AND VACTORING ANNUALLY OR WHEN INSPECTION SHOWS THAT MAINTENANCE IS NECESSARY.

NOTES:

- CHAMBERS SHALL MEET THE REQUIREMENTS OF ASTM F2922 (POLYETHYLENE) OR ASTM F2418 (POLYPROPYLENE), "STANDARD SPECIFICATION FOR CORRUGATED WALL STORMWATER COLLECTION CHAMBERS".
- SC-310 CHAMBERS SHALL BE DESIGNED IN ACCORDANCE WITH ASTM F2787 "STANDARD PRACTICE FOR STRUCTURAL DESIGN OF THERMOPLASTIC CORRUGATED WALL STORMWATER COLLECTION CHAMBERS".
- THE SITE DESIGN ENGINEER IS RESPONSIBLE FOR ASSESSING THE BEARING RESISTANCE (ALLOWABLE BEARING CAPACITY) OF THE SUBGRADE SOILS AND THE DEPTH OF FOUNDATION STONE WITH CONSIDERATION FOR THE RANGE OF EXPECTED SOIL MOISTURE CONDITIONS. REFERENCE STORMTECH DESIGN MANUAL FOR BEARING CAPACITY GUIDANCE.
- PERIMETER STONE MUST BE EXTENDED HORIZONTALLY TO THE EXCAVATION WALL FOR BOTH VERTICAL AND SLOPED EXCAVATION WALLS.
- REQUIREMENTS FOR HANDLING AND INSTALLATION:
 - TO MAINTAIN THE WIDTH OF CHAMBERS DURING SHIPPING AND HANDLING, CHAMBERS SHALL HAVE INTEGRAL, INTERLOCKING STACKING LUGS.
 - TO ENSURE A SECURE JOINT DURING INSTALLATION AND BACKFILL, THE MATERIAL JOINT SHALL NOT BE LESS THAN 2".
 - TO ENSURE THE INTEGRITY OF THE ARCH SHAPE DURING INSTALLATION, THE ARCH STIFFNESS CONSTANT SHALL BE GREATER THAN OR EQUAL TO 400 LBS/FT². THE ASC IS DEFINED IN SECTION 6.2.8 OF ASTM F2418, AND b) TO RESIST CHAMBER DEFORMATION DURING INSTALLATION AT ELEVATED TEMPERATURES (ABOVE 73° F / 23° C), CHAMBERS SHALL BE PRODUCED FROM REFLECTIVE GOLD OR YELLOW COLORS.

1 SC-310 CROSS SECTION DETAIL

DATE: 09/13/2024
 PROJECT #:
 DRAWN: AB
 CHECKED: N/A
 REV: NOT TO SCALE

POPEYE'S
 KANSAS CITY, MO, USA

StormTech®
 Chamber System
 1-800-821-8710 | WWW.STORMTECH.COM

4640 TRUEMAN BLVD
 HILLIARD, OH 43026
 1-800-733-7473

SHEET
 1 OF 1

INFILTRATION TRENCH DETAILS
 POPEYE'S LOUISIANA KITCHEN
 KANSAS CITY, CLAY COUNTY, MISSOURI
 SITE ADDRESS: 9806 N. OAK TRAFFICWAY

PHILIPS ENGINEERING, INC.
 1370 N. Winchester
 Olathe, Kansas 66061
 (913) 993-1155
 Fax: (913) 993-1165
 www.philipsengineering.com

PLANNING
 ENGINEERING
 IMPLEMENTATION

PEI

PROJECT NO. 230374
 DATE: 09-29-2024
 DRAWN: AEB
 CHECKED: DAF
 APPROVED: DAF
 CREDENTIALS: DAF
 LICENSE NO.: LS-82
 LICENSE TYPE: E-361
 EXPIRES: 06/30/2028
 LICENSE NO.: 200700128
 LICENSE TYPE: E-361
 EXPIRES: 06/30/2028

SHEET
 C401



Know what's below.
Call before you dig.

UTILITY NOTES:
VISUAL INDICATIONS OF UTILITIES ARE SHOWN.
UNDERGROUND LOCATIONS SHOWN, AS FURNISHED BY THEIR LESSORS, ARE APPROXIMATE AND SHOULD BE VERIFIED IN THE FIELD AT THE TIME OF CONSTRUCTION. FOR ACTUAL FIELD LOCATIONS OF UNDERGROUND UTILITIES CALL 811.

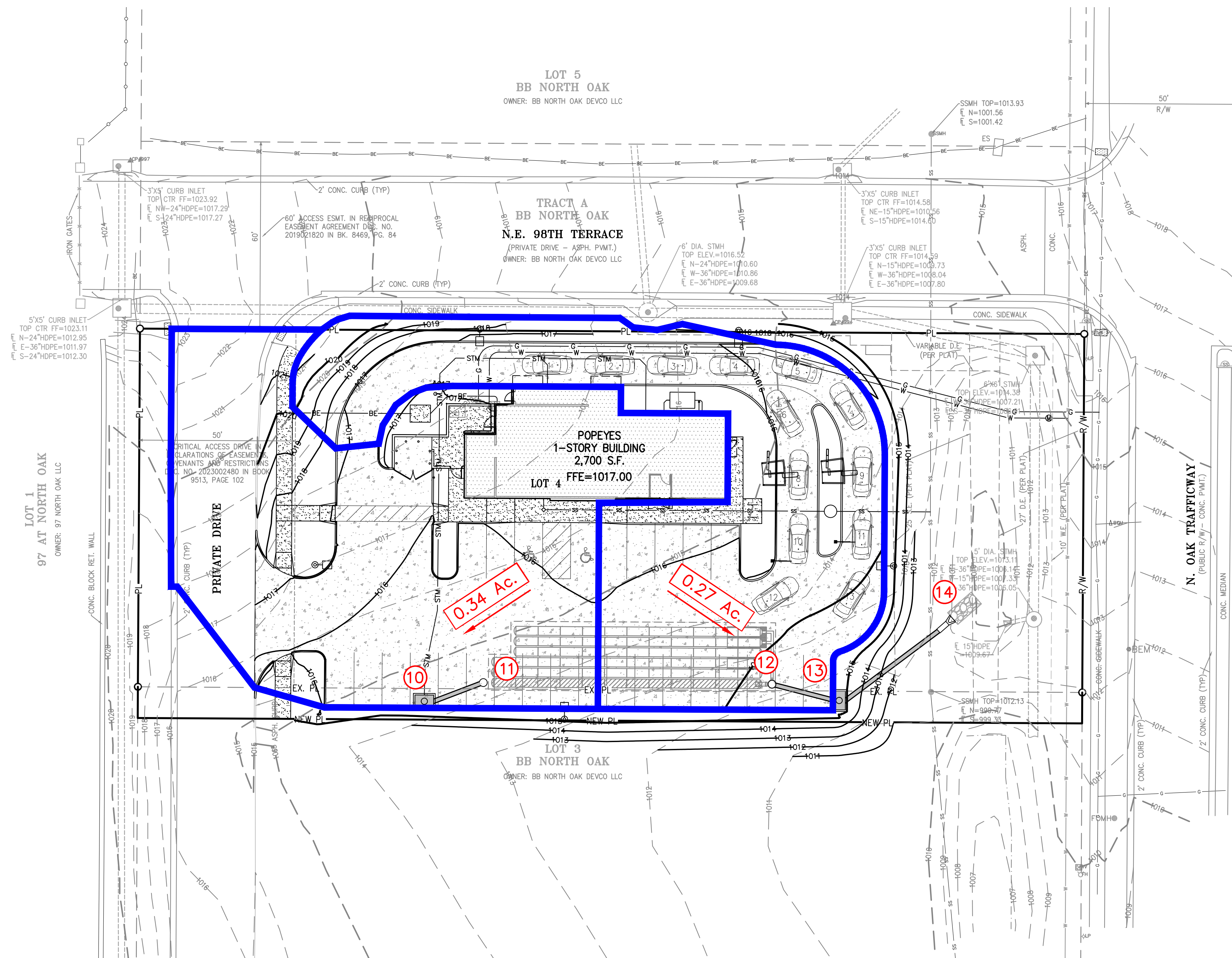

STORM DRAINAGE CALCULATIONS

DESIGN CRITERIA: $K_{25} = 1.1$; $K_{100} = 1.25$; $n = 0.013$ (RCP);										III. PIPE DESIGN				REMARKS				
N L U I M N B E R	S T R U C T U R E	INCREMENTAL		CUMULATIVE		SYSTEM TIME OF CONCENTRATION "T _c " AT STRUCTURE (MIN)	RAINFALL INTENSITY "I ₂ " / I ₁₀ " (IN/HR)	ANTECEDENT PRECIPITATION FACTOR "K ₂ " / K ₁₀ "	RUNOFF "Q ₂ " / Q ₁₀ " (CFS)	STRUCTURE		PIPE						
		RUNOFF COEFFICIENT "C"	AREA "A" (ACRES)	C x A	AREA "A" (ACRES)					C x A	Upstream Structure Number	Downstream Structure Number	Diameter "D" (IN)	Slope "S" (FT/FT)	Velocity Full V _f (FPS)	Ranoff Q ₂ (CFS)	Ranoff Q ₁₀ (CFS)	Full Flow Q ₁₀ (CFS)
1	10	0.81	0.34	0.28	0.34	0.28	8.53	1.10	2.6	10	11	15	0.0200	7.5	2.6	3.6	9.1	GOOD
	13	0.81	0.27	0.22	0.27	0.22	8.53	1.10	2.1	13	12	15	0.0200	7.5	2.1	2.8	9.1	GOOD
	13	0.81	0.27	0.22	0.61	0.50	8.53	1.10	4.7	13	14	15	0.0130	6.0	4.7	6.5	7.4	GOOD
								10.32	1.25	6.5								

LEGEND

- XXX--- EXISTING CONTOURS
- XXX--- PROPOSED CONTOURS
- XXX--- DENOTES DRAINAGE AREA
- XXX--- DENOTES FLOW DIRECTION
- X.XX Ac. DENOTES DRAINAGE AREA TO STRUCTURE
- ⊗ DENOTES STRUCTURE NUMBER

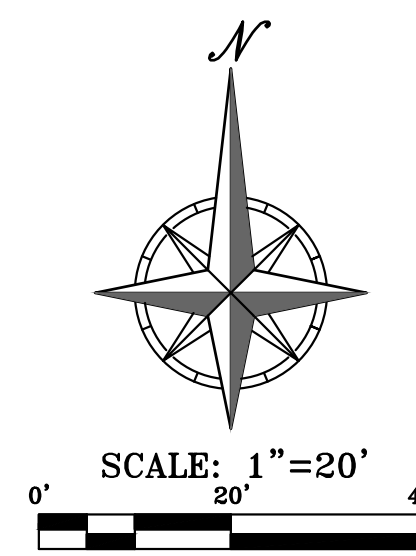

PHELPS ENGINEERING, INC.
1370 N. Winchester
Olathe, Kansas 66061
(913) 993-1155
Fax (913) 993-1165
www.pelpsengineering.com

PLANNING
ENGINEERING
IMPLEMENTATION

DRAINAGE MAP
POPEYE'S LOUISIANA KITCHEN
KANSAS CITY, CLAY COUNTY, MISSOURI
SITE ADDRESS: 9806 N. OAK TRAFFICWAY

PROJECT NO.	Date	By	App.
230374	10-18-2024	AEB	DAF
DATE: 09-29-2024 [DRAWN: AEB]			
CHECKED: DAF [APPROVED: DAF]			
CORPORATE SEAL OF AUTHORIZATION			
LAND SURVEYING - LS-82			
ENGINEERING - E-361			
CERTIFICATE OF AUTHORIZATION			
LAND SURVEYING: 200700128			
ENGINEERING: 200300308			

SHEET
C500

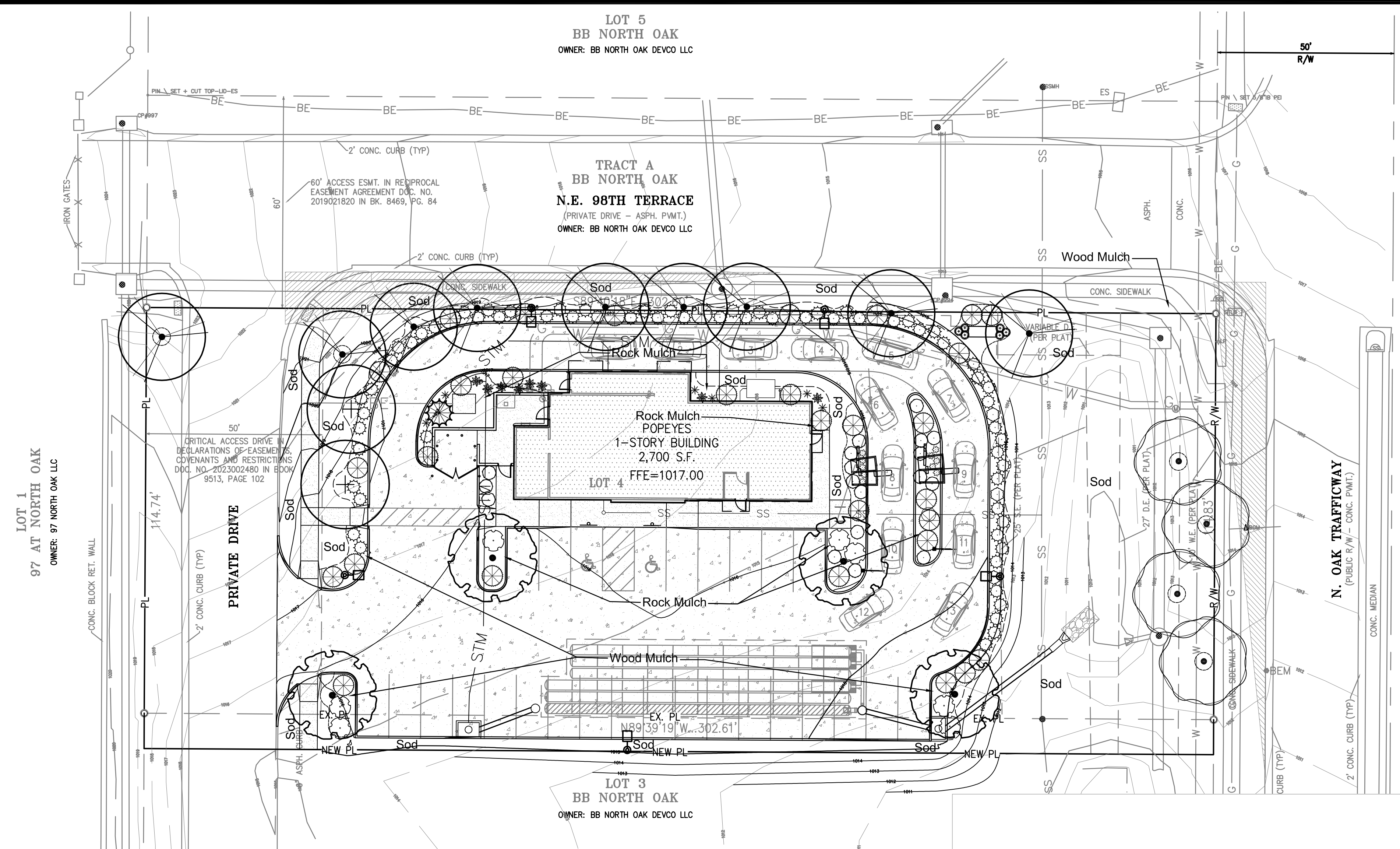

PLANT_SCHEDULE

SYMBOL	QTY	BOTANICAL / COMMON NAME	CONT	CAL	SIZE
TREES					
	4	Acer rubrum 'Red Pointe' / Red Pointe Red Maple	B & B		2"Cal
	2	Gleditsia triacanthos 'Skyline' / 'Skyline' Honey Locust	B & B		2"Cal
	4	Gymnocladus dioica 'Espresso' / Kentucky Coffee Tree Seedless/Male Only	B & B		2"Cal
	1	Juniperus virginiana 'Canaerti' / Canaerti Juniper	B & B		6' hgt.
	9	Quercus bicolor / Swamp White Oak	B & B		2"Cal
SHRUBS					
	18	Cornus sericea 'Kelsey' / Kelsey Dogwood 24"-30" hgt. & sp.	5 gal		
	3	Hypericum frondosum 'Sunburst' / Sunburst Hypericum 18"-24" hgt. & sp.	2 gal		
	64	Ilex glabra 'Shamrock' / Inkberry 36" hgt.	5 gal		
	31	Juniperus chinensis 'Sea Green' / Sea Green Juniper 36" hgt. & sp.	5 gal		
	7	Rhus aromatica 'Gro-Low' / Gro-Low Fragrant Sumac 18"-24" sp.	3 gal		
	10	Rosa x 'Novarosop' / Popcorn Drift Rose 12"-15" sp.	1 gal		
GRASSES					
	6	Panicum virgatum 'Heavy Metal' / Blue Switch Grass 18"-24" hgt.	3 gal		
	6	Panicum virgatum 'Shenendoah' / Burgundy Switch Grass 15"-18" hgt.	1 gal		
	8	Sorghastrum nutans 'Sioux Blue' / Blue Indian Grass 18"-24" hgt.	3 gal.		

Table 3b. Landscape Schedule

This table shall appear on all landscape plans and be used to identify the graphic information displayed on the face of the plan.

88-425 - LANDSCAPE SCHEDULE	SYMBOL
88-425-03 Street Trees	See plan and plant schedule
88-425-04 General	See plan and plant schedule
88-425-05 Perimeter Vehicular Use Area Adjacent to Streets	See plan and plant schedule
Buffer Width	
Trees	See plan and plant schedule
Shrubs/Wall/Berm	See plan and plant schedule
Adjacent to Residential Zones	
Buffer Width	
Shrubs/Berm/Fence/Wall	See plan and plant schedule
88-425-06 Interior Vehicular Use Area	
Interior Area	See plan and plant schedule
Trees	See plan and plant schedule
Shrubs	See plan and plant schedule
88-425-07 Parking Garage Screening	Describe
88-425-08 Mechanical/Utility Equipment Screening	Describe
88-425-09 Outdoor Use Screening	Describe

Table 3. Landscape Requirements

This table shall appear on all landscape plans. Note that the column labeled "Alternative Requested" shall only be used when you cannot meet the landscape requirement and, if used, must be accompanied by Table 3a.

88-425 - LANDSCAPE REQUIREMENTS	Required	Proposed	Alternative Requested?	Approved
88-425-03 Street Trees	13	13		
88-425-04 General	1	1		
88-425-05 Perimeter Vehicular Use Area Adjacent to Streets				
Buffer Width	10 ft.	20 ft.+		
Trees	10	10		
Shrubs/Wall/Berm				
Adjacent to Residential Zones				
Buffer Width	NA			
Shrubs/Berm/Fence/Wall				
88-425-06 Interior Vehicular Use Area				
Interior Area	945 S.F.	1817 S.F.		
Trees	54	6		
Shrubs	27	27+		
88-425-07 Parking Garage Screening	Describe	NA		
88-425-08 Mechanical/Utility Equipment Screening	Describe	NA		
88-425-09 Outdoor Use Screening	Describe	NA		

Table 3a. Alternative Compliance to Landscape Standards

This table shall appear on all landscape plans in which alternative compliance is requested.

88-425 - LANDSCAPE REQUIREMENTS	Proposed Alternative	Approved
88-425-03 Street Trees	NA	
88-425-04 General	NA	
88-425-05 Perimeter Vehicular Use Area Adjacent to Streets	NA	
Buffer Width		
Trees		
Shrubs/Wall/Berm		
Adjacent to Residential Zones		
Buffer Width	NA	
Shrubs/Berm/Fence/Wall		
88-425-06 Interior Vehicular Use Area		
Interior Area	NA	
Trees		
Shrubs		
88-425-07 Parking Garage Screening	NA	
88-425-08 Mechanical/Utility Equipment Screening	NA	
88-425-09 Outdoor Use Screening	NA	

Utility Note:
Utilities shown on plan are diagrammatic and some may be missing. Before starting any construction call appropriate locating service. In Missouri call 1-800-DIG-RITE (344-7483) to have utilities located.

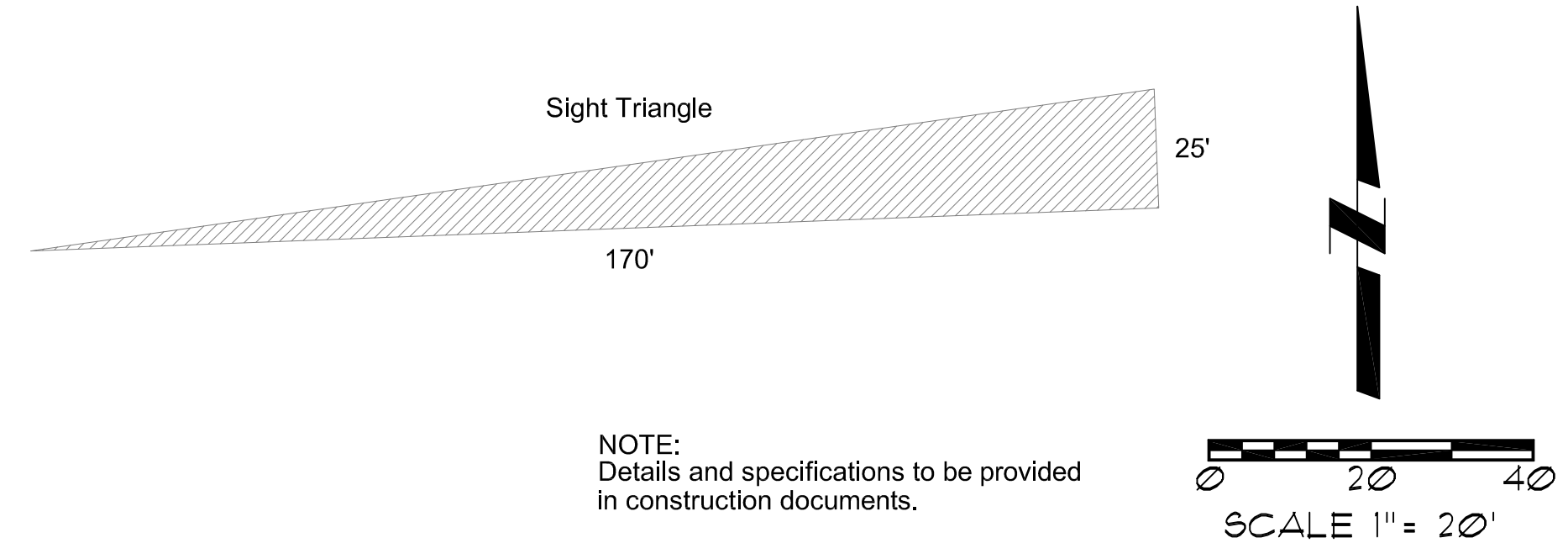

NOTE: Details and specifications to be provided in construction documents.

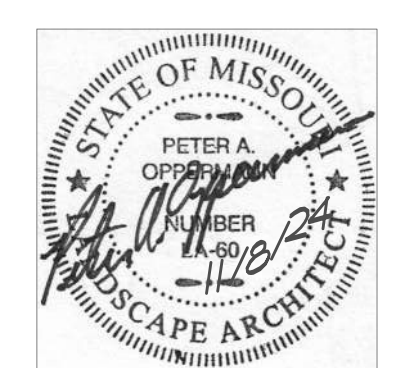

Landscape Plan
Popeye's
NE 98th Terrace and North Oak Trafficway
Kansas City, Missouri

Oppermann LandDesign, LLC
Land Planning + Landscape Architecture
22 Debra Lane peteoppermann56@gmail.com
New Windsor, New York 12553 913.592.5598

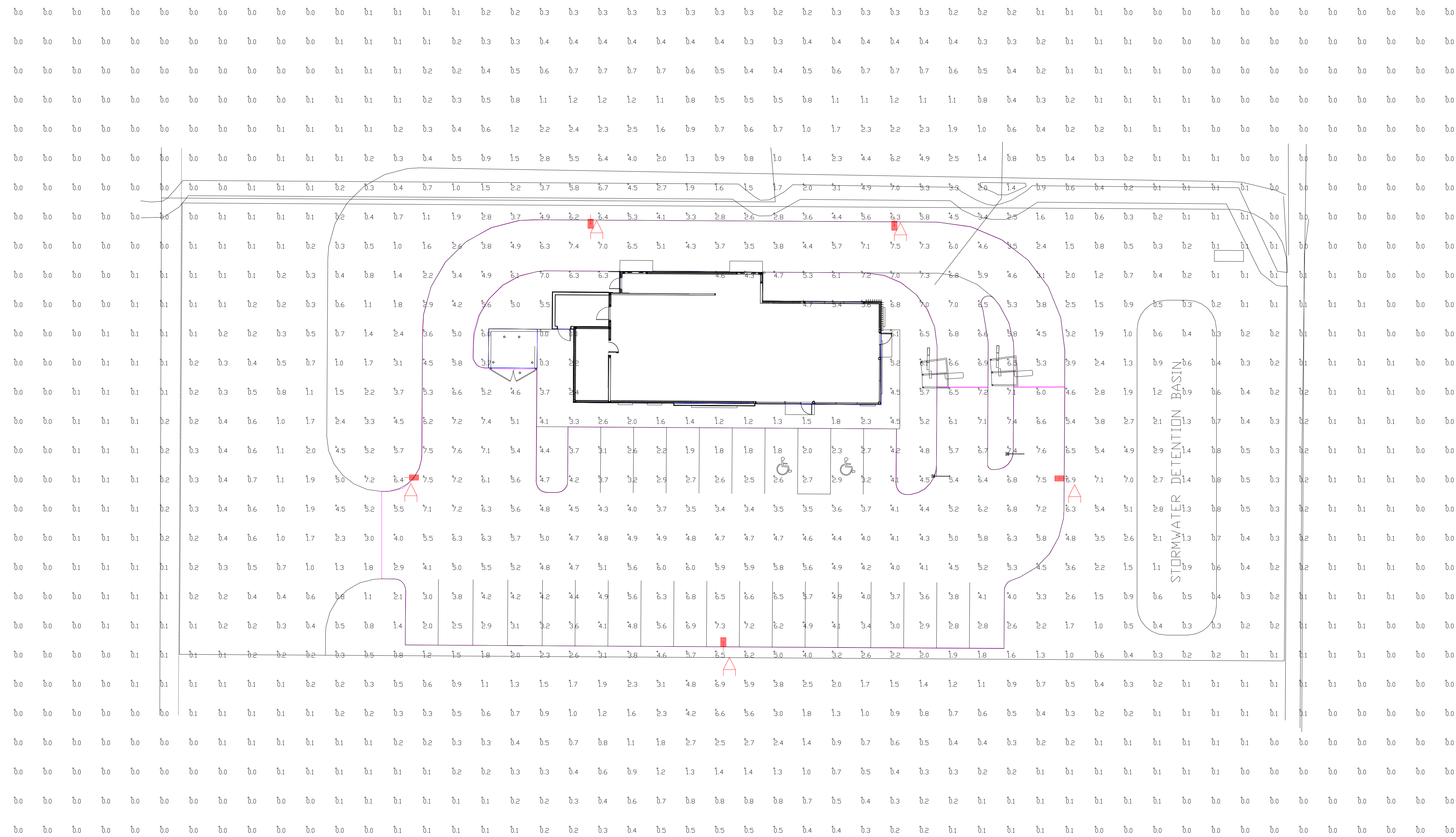

Calculation Summary							
Label	CalcType	Units	Avg	Max	Min	Avg/Min	Max/Min
ALL CALCS AT GRADE	Illuminance	Fc	1.48	7.6	0.0	N.A.	N.A.
PAVED AREA	Illuminance	Fc	4.96	7.6	1.8	2.76	4.22

POLE NOTE: 4SQ-XX-S11G-22.5 POLE + 2.5FT BASE
POLE ORDERING INFORMATION BASED ON THIS DRAWING:
PLEASE CONFIRM EPA WIND RATING PRIOR TO ORDER.
CUSTOMER RESPONSIBLE FOR BASE SELECTION PER LOCAL CONDITIONS.

Luminaire Schedule										
Symbol	Qty	Label	Arrangement	Description	Mounting Height	LLD	LLF	Arr. Lum. Lumens	Arr. Watts	
	5	A	Single	MRS-LED-30L-SIL-FT-50-CRI-SINGLE	22.5' POLE + 2.5' BASE	1.000	1.000	32235	209	

PHOTOMETRIC EVALUATION
 NOT FOR CONSTRUCTION

Based on the information provided, all dimensions and luminaire locations shown represent recommended positions. The engineer and/or architect must determine the applicability of the layout to existing or future field conditions.

This lighting plan represents illumination levels calculated from laboratory data taken under controlled conditions in accordance with The Illuminating Engineering Society (IES) approved methods. Actual performance of any manufacturer's luminaires may vary due to changes in electrical voltage, tolerance in lamps/LED's and other variable field conditions. Calculations do not include obstructions such as buildings, curbs, landscaping, or any other architectural elements unless noted. Fixture nomenclature noted does not include mounting hardware or poles. This drawing is for photometric evaluation purposes only and should not be used as a construction document or as a final document for ordering product.

Total Project Watts
 Total Watts = 1045

1000 ALLIANCE RD. CINCINNATI, OHIO 45244 USA
 (513) 793-0200 • FAX (513) 793-0203

LIGHTING PROPOSAL LO-160997

POPEYES
 97TH & N DAK
 KANSAS CITY, MO

BY:DK	DATE:9/11/24	REV:	SHEET 1 OF 1
-------	--------------	------	--------------

SCALE: 1"=16' 0 16

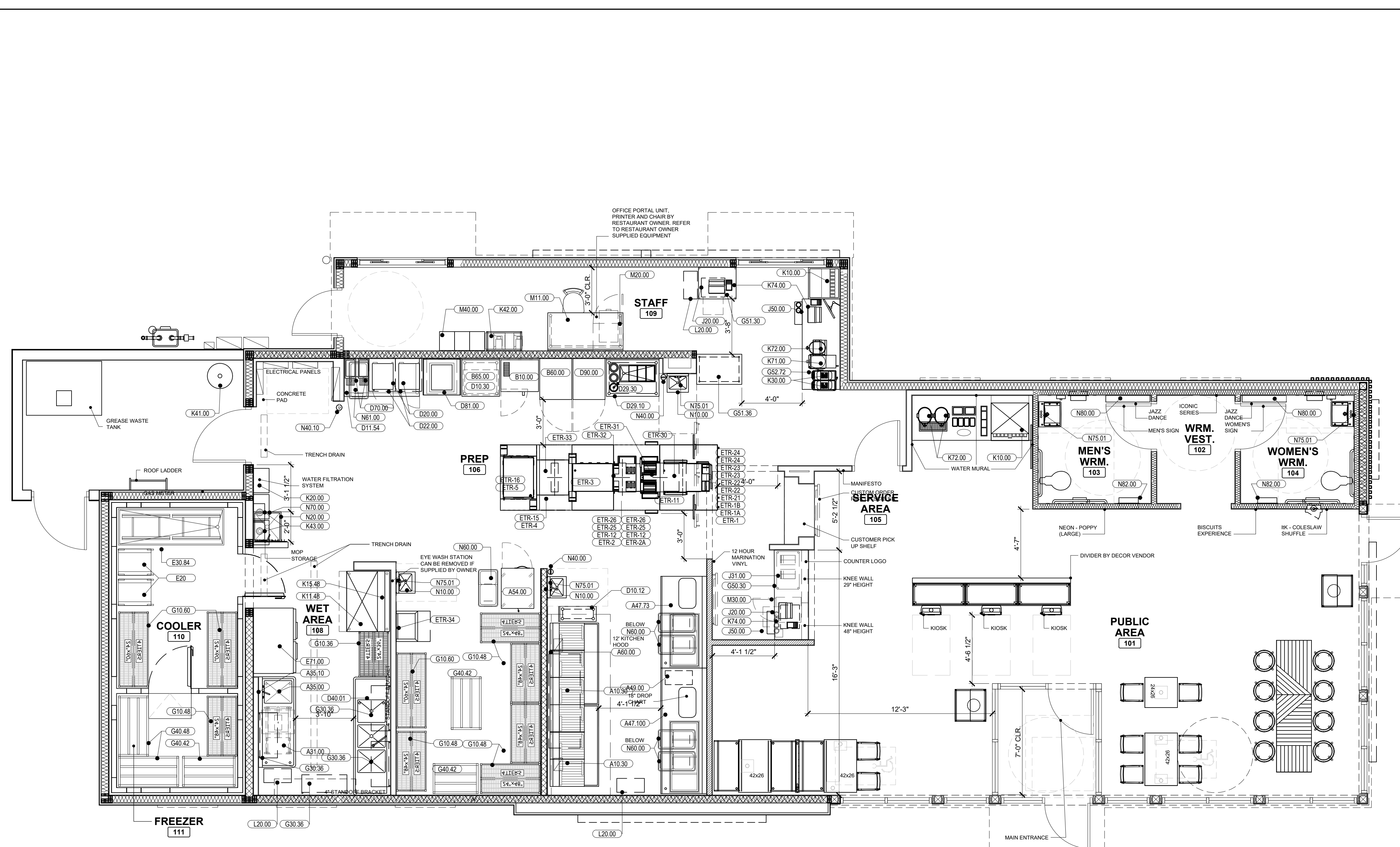

1 EQUIPMENT PLAN
 SCALE: 1/4"=1'-0"
 NORTH

NEW KITCHEN EQUIPMENT SCHEDULE

NOTE: CONTRACTOR SHOULD REFER TO MANUFACTURER SPECIFICATIONS FOR ALL SERVICE REQUIREMENTS AND PROPER CONNECTIONS.

ITEMNO	QTY	CATEGORY	MFR	MODEL	EQUIPMENT REMARKS
A10.30	2	MULTIPLE FRYER SYSTEM, GAS	ULTRAFRYER	BP20203 UCP	
A10.50	2	SHORTENING DISPOSAL UNIT	ULTRAFRYER	DISPOSAL	NOT SHOWN IN PLAN
A10.50	2	BOILOUT HOSE	ULTRAFRYER	BOILOUT	NOT SHOWN IN PLAN
A31.00	1	MARINATOR	AYRKING	M101-110	
A35.00	1	ONE COMPARTMENT SINK	WINHOLT	1143828	
A35.10	3	PRE-RINSE FAUCET ASSEMBLY	T & S BRASS	B2180	
A47.73	1	BATTER STATION 73"	AYRKING	BBSUL7335	W/ 14" EDGE
A47.100	1	BATTER STATION 100"	AYRKING	BBS-U-10032	
A49.00	1	DRUMROLL	AYRKING	DRUF120TPR BPOF	
A54.00	1	REACH-IN FREEZER	DELFIELD	GBR1P-S	
A60.00	1	12" HOOD	FRANKIE	3347 FR-BB-2	
B10.00	1	CONVECTION OVEN, DOUBLE STACKED	BLOGGETT OVEN	CTB DBL	
B60.00	1	REACH-IN REFRIGERATOR	DELFIELD	GBR1P-S	
B65.00	1	BISCUIT HOLDING UNIT	KES	CUSTOM	
D10.12	1	WORK TABLE - 12"	KES	CUSTOM	
D10.30	1	WORK TABLE - 30"	KES	CUSTOM	
D11.54	1	WORK TABLE - 54"	KES	CUSTOM	
D20.00	2	MICROWAVE OVEN	PANASONIC	NE-17523	
D22.00	2	MICROWAVE SHELF	KES	CUSTOM	
D29.10	1	PACKING TABLE, CONSERVEWELL UTENSIL HDR.	SERVER	CW-DI	
D29.30	1	PACKING TABLE, DOUBLE SIDED	KES	CUSTOM	
D40.01	1	3-COMPARTMENT SINK (64" W/ 18" DB L & R)	UNIVERSAL STAINLESS	3N-1824-2D18	
D40.03	1	SPLASH DIVIDER	KES	CUSTOM	
D41.00	1	CLEAN DISHTABLE	ADVANCE TABCO	DTC-S60-24R	
D50.00	1	DISHWASHER	HOBART	AM-16VLT-2	
D70.00	2	HOT WATER DISPENSER	BUNN	H5E	
D81.00	1	REHEAT/REHEAT WATER TANK, ELECTRIC	ULTRAFRYER	REC-1620-X	
D90.00	1	PROOFER CABINET, MOBILE	WINSTON	HA4522	
E10.00	1	WALK-IN COOLER	KOLPAK	CUSTOM	
E20.00	2	CHICKEN RACKS	SPQ	4H1286	
E30.84	1	CHICKEN CRATE	NWS	D125050500N	
E71.20	1	DOUBLE EVEN-THAW REFRIGERATOR	TRAUlsen	RE232N-1	
ETR-1	1	LANDING ZONE MODULE	DUKE	1141-2007	
ETR-1A	1	UNDERCOUNTER REFRIGERATED UNIT	SILVER KING	SKRS28	
ETR-1B	1	DROP-IN FRY HOLDING UNIT	H&K	POP279	
ETR-2	1	SANDWICH STATION MODULE	DUKE	1141-2003	
ETR-2A	1	REFRIGERATOR SANDWICH STATION	DUKE	FCP2-SB-120-BI-BC-ND	
ETR-3	1	MULTI-PROTEIN STATION MODULE	DUKE	1141-2004	
ETR-4	1	BONE-IN CHICKEN STATION MODULE	DUKE	1141-2005	
ETR-5	1	EXTENDED HOLDING MODULE	DUKE	1141-2005	
ETR-11	1	PRODUCT HOLDING UNIT - SIDES	DUKE	RFHU-32F	
ETR-12	2	VERTICAL CONTACT TOASTER	ANTUNES	VCT-2	
ETR-12	2	PRODUCT HOLDING UNIT - MULTI PROTEIN	DUKE	RFHU-52F	
ETR-14	1	BONE-IN CHICKEN BIRDCAFE	CARTER-HOFFMAN	FFS3V-25	
ETR-16	1	EXTENDED HOLDING CABINET	-	-	
ETR-21	2	LANDING ZONE MONITOR	-	-	
ETR-22	2	KDS MONITOR	-	-	
ETR-23	2	LANDING ZONE PRINTER	-	-	
ETR-24	2	MULTI-PROTEIN PRINTER	-	-	
ETR-25	2	SANDWICH PRINTER	-	-	
ETR-26	2	BONE-IN CHICKEN PRINTER	-	-	
ETR-27	2	BONE-IN CHICKEN PRINTER	-	-	
ETR-30	1	OEP BOX	FRANKE	18028545	
ETR-31	1	OEP BOX	FRANKE	18028542	
ETR-32	1	OEP BOX	FRANKE	18028504	
ETR-33	1	OEP BOX	FRANKE	18028505	
ETR-34	1	BATTER MAKER	H&K	POP450-1	
G10.48	7	COATED WIRE SHELVING - 4 TIERS 48"	METRO	2448N3	
G10.60	3	COATED WIRE SHELVING - 4 TIERS 60"	METRO	2448N3	
G30.36	4	WIRE SHELVING WALL MOUNTED - 2 TIERS	METRO	1436N3	
G40.42	3	DUNNAGE RACK	KES	CUSTOM	
G40.48	2	DUNNAGE RACK	KES	CUSTOM	
G50.30	1	WIRE SHELVING - 2 TIERS - 30"	METRO	CUSTOM	
G51.30	1	POS TABLE - 30"	METRO	CUSTOM	
G51.36	1	POS TABLE - 36"	METRO	CUSTOM	
G52.72	1	DRIVE THRU TABLE - 72"	KES	CUSTOM	
G55.42	1	EXPO TABLE	KES	CUSTOM	
J20.00	2	CASH CONTROLLER	NKL INDUSTRIES	W-101	
J31.00	1	CONDIMENT ORGANIZER BIN RACK	CAMBRO	12RS12	
J50.00	2	DISPOSABLE CUP DISPENSER	DISPENSE-RITE	WR-CC-22-POP	
K10.00	2	SODA MACHINE	MANITOWOC	BF920C	
K11.48	1	ICE MAKER, CUBE-STYLE 48"	HOSHIZAKI		
K15.48	1	ICE BIN 48"	HOSHIZAKI	8700-SF	
K20.00	1	WATER FILTER SYSTEM	EVERPURE	EV843710	
K30.00	1	FROZEN LEMONADE	BUNN	34000.0012	
K40.00	1	GREASE TANK			
K41.00	1	C02 TANK			
K42.00	1	BAG N BOX			BY OTHERS
K43.00	2	WATER HEATERS			BY OTHERS
K71.00	1	TEA BREWER	BUNN	ITCB	
K72.00	4	TEA DISPENSER	BUNN	TD040	
K74.00	3	POS			BY OTHERS
L20.00	3	TRASH BINS			
LP45.00	1	OUTSIDE TRASH RECEPTACLE	WAUSAU	TF1015	NOT SHOWN IN PLAN
LP46.00	1	OUTSIDE TRASH RECEPTACLE	WAUSAU	TF1021	NOT SHOWN IN PLAN
M11.00	1	MANAGERS DESK	NWS	F367310100N	
M20.00	1	OFFICE SUPPLIES	WASSER	106053	
M30.00	1	SAFE	FIRE KING	BSD2920	
M40.00	1	LOCKERS W/ 6 HIGH UNIT	KELMAX	EL SERIES	
N10.00	4	HAND SINK	KROVINE	HS-68	
N40.00	1	FIRE EXTINGUISHER	ACTION	436500	CLASS K
N40.10	3	FIRE EXTINGUISHER	ACTION	434909	
N60.00	4	INGREDIENTS BIN	RUBBERMAID	FG360288WHT	
N61.00	1	INGREDIENTS BIN	RUBBERMAID	FG360288WHT	
N20.00	1	MOP SINK (24"x36")	FIAT	MSB3624	
N70.00	1	MOP & BROOM HAGER	ADVANCED	K242	
N75.01	6	FAUCET	KROVINE	16-197	
W16.00	2	DRIVE-THRU WINDOW	QUIKSERV	BP-72x	

NOTE

- IT IS RESPONSIBILITY OF THE G.C. TO COORDINATE DELIVERY, UNCRATING, POSITIONING, FINAL HOOK UP AND REMOVAL OF TRASH OF ALL OWNER SUPPLIED KITCHEN EQUIPMENT.
- ALL KITCHEN EQUIPMENT TO BE INSTALLED AS PER MANUFACTURERS SPECIFICATIONS.
- DECOR ITEMS SUPPLIED BY OWNER AND INSTALLED BY GENERAL CONTRACTOR.
- FOR DINING ROOM FURNITURE, SEE DECOR PACKAGE, CONTACT DECOR VENDOR FOR DETAILS.
- ARCHITECT OF RECORD TO ENSURE AND COORDINATE THAT ALL INTERIOR AND EXTERIOR COMPLIES WITH ADA REQUIREMENTS AS WELL AS LOCAL JURISDICTIONS.
- AS OF DECEMBER 31, 2021, CAPTIVE AIRE NO LONGER MANUFACTURERS OR SELLS THE POPEYES LOW PROFILE HOOD. THE ONLY APPROVED HOOD IS THE FRANKIE PLK HOOD. THE ONLY APPROVED HOOD IS THE FRANKIE PLK HOOD. CAD DWGS AND SPECS CAN BE FOUND IN THE DESIGN PORTAL ON THE EQUIPMENT SCHEDULE TAB.
- CO2 MONITOR TO BE PROVIDED AT THE CO2 TANK. GC TO COORDINATE WITH CO2 TANK VENDOR AND POPEYES FOR MONITOR AND SPEC.

ISSUE TABLE

No.	Date (mm/dd/yy)	Description
01	24.07.23	6095 PROTOTYPE DOCUMENTS

REVISIONS

No.	Date	Description
-----	------	-------------

DRAWINGS REVISED AS PER DESIGN BULLETIN

No.	Date	Description
-----	------	-------------

THIS DRAWING IS OWNED BY OR LICENSED FOR USE BY POPEYES LOUISIANA KITCHEN OR ITS AFFILIATED OR RELATED COMPANIES AND MAY NOT BE REPRODUCED, USED, DOWNLOADED, DISSEMINATED, PUBLISHED OR TRANSMITTED IN ANY FORM OR BY ANY MEANS, EXCEPT WITH THE PRIOR WRITTEN CONSENT OF POPEYES LOUISIANA KITCHEN. COPYRIGHT INFRINGEMENT IS A VIOLATION OF FEDERAL LAW SUBJECT TO CRIMINAL AND CIVIL PENALTIES.

THE CONTRACTOR IS TO VERIFY ALL DIMENSIONS AND CONDITIONS ON THE PROJECT AND TO REPORT ANY DISCREPANCIES TO THE POPEYES LOUISIANA KITCHEN REPRESENTATIVE WORK COMMENCING WORK. THESE DRAWINGS ARE NOT TO BE USED FOR CONSTRUCTION PURPOSES UNLESS INDICATED BY POPEYES LOUISIANA KITCHEN AS "ISSUED FOR CONSTRUCTION".

Company Logo

WARMAN ARCHITECTURE-DESIGN
 1735 SWIFT AVE.
 NORTH KANSAS CITY, MISSOURI 64116
 V. 816.474.2233 F. 816.474.1051

Project

POPEYES

Store Type
 US 2124 PROTOTYPE
 2124-21

Location
 97th Street &
 North Oak Trafficway
 Kansas City, MO

Drawing Title
EQUIPMENT PLAN & SCHEDULES

Drawn
 cdt

Checked
 KAW

Scale
 1/4"=1'-0"

Date
 July 23, 2024

Project No.
 6095-24

Drawing No.
 A2.0

POPEYES LOUISIANA KITCHEN MODEL 2124, ADDRESS: CITY, STATE: 2124 PROTOTYPE DOCUMENTS (OCT 27, 2021) STORE NO. XXXX

EXTERIOR FINISH SCHEDULE

Table with columns: TAG, MATERIAL, APPLICATION, MANUFACTURER, PRODUCT, COLOR/FINISH, DIMENSION. Includes sections for FINISH MATERIALS, EXTERIOR PAINTS, and EXTERIOR MISC.

EXTERIOR ELEVATION NOTES

- 1 PRE-FINISHED METAL CAP FLASHING CW DRIP.
2 G.C TO PROVIDE AND INSTALL DOUBLE LAYER OF REINFORCING MESH TO MIN. 2" ABOVE GRADE AT ALL EIFS LOCATIONS (TYP.) IN ORDER TO ATTAIN ABUSE RESISTANCE STUCCO SYSTEM.
3 NICHHA VINTAGEBRICK, COLOR: ALEXANDRIA BUFF. REFER TO POPEYES MASTER SCHEDULE.
4 NICHHA VINTAGEBRICK, COLOR: WHITE WASH. REFER TO POPEYES MASTER SCHEDULE.
5 EIFS. REFER TO POPEYES MASTER SCHEDULE.
6 PRE-FINISHED 'BLACK ANODIZED' ALUMINUM STOREFRONT SYSTEM WITH INSULATED GLAZING.
7 EXPOSED FOUNDATION TO BE PARGED AND FREE OF IMPERFECTIONS.
8 GAS UTILITY METER.
9 REFER TO STRUCTURAL DRAWINGS FOR FOUNDATION WALL AND FOOTING DETAILS.
10 INTERNALLY ILLUMINATED BUILDING SIGNAGE PROVIDED AND INSTALLED BY SIGN COMPANY. G.C TO PROVIDE AND INSTALL 3/4" EXTERIOR GRADE PRESSURE TREATED PLYWOOD BACKING AND ALL FINAL ELECTRICAL CONNECTION. SIGN MANUFACTURER SHALL OBTAIN STRUCTURALLY SEALED DRAWINGS AND SIGNAGE PERMITS FROM THE CITY BASED ON LOCAL REQUIREMENTS. G.C SHALL VERIFY ACTUAL LOCATION & SIZE OF SIGNS WITH SIGN MANUFACTURER'S APPROVED DRAWINGS AND COORDINATE LOCATIONS OF BLOCKING AND UTILITIES. G.C TO COORDINATE WITH SIGN INSTALLER TO USE VHM DRILL BIT WHILE DRILLING FOR ELECTRICAL FEED LINES AND SIGNAGE FASTENERS. ALL ELEMENTS PROVIDED BY SIGNAGE FABRICATOR TO BE REVIEWED AND APPROVED BY POPEYES PRIOR TO PRODUCTION.
11 NON-ILLUMINATED BUILDING SIGNAGE PROVIDED AND INSTALLED BY SIGN COMPANY. G.C TO PROVIDE AND INSTALL 3/4" EXTERIOR GRADE PRESSURE TREATED PLYWOOD BACKING. SIGN MANUFACTURER SHALL OBTAIN STRUCTURALLY SEALED DRAWINGS AND SIGNAGE PERMITS FROM THE CITY BASED ON LOCAL REQUIREMENTS. G.C SHALL VERIFY ACTUAL LOCATION & SIZE OF SIGNS WITH SIGN MANUFACTURER'S APPROVED DRAWINGS AND COORDINATE LOCATIONS OF BLOCKING AND UTILITIES. G.C TO COORDINATE WITH SIGN INSTALLER TO USE VHM DRILL BIT WHILE DRILLING FOR ELECTRICAL FEED LINES AND SIGNAGE FASTENERS. ALL ELEMENTS PROVIDED BY SIGNAGE FABRICATOR TO BE REVIEWED AND APPROVED BY POPEYES PRIOR TO PRODUCTION.
12 NICHHA VINTAGE WOOD, COLOR: CEDAR. REFER TO POPEYES MASTER SCHEDULE.
13 PROVIDE & INSTALL 6" DIAMETER STEEL PIPE BOLLARD TOP AT 4'-8" A.F.F. G.C. TO PAINT 'SAFETY YELLOW'. REFER TO POPEYES MASTER SCHEDULE.
14 DRIVE-THRU WINDOW. REFER TO DRIVE-THRU WINDOW SCHEDULE ON SHEET A11.
15 CMU ENCLOSURE WITH PLASTER APPLIED TO EXTERIOR OF ENCLOSURE WITH A SMOOTH CONTINUOUS SURFACE. PAINT PLASTER EP-3.
16 OVERFLOW SCUPPER. FLOW LINE TO BE 2" (HOLD) ABOVE FLOW LINE OF ROOF SCUPPER.
17 N/A.
18 DASHED LINE INDICATES T/O OF ROOF BEHIND PARAPET.
19 C/T CABINET AND METER.
20 LINE OF PARAPET WALLS BEYOND.
21 GENERAL PURPOSE EXTERIOR LIGHTING FIXTURES.
22 WALK-IN COOLER/FREEZER FINISH TO BE COMPLETED BY MANUFACTURER.
23 METAL RAILING SUPPLIED AND INSTALLED BY G.C (ONLY IF REQUIRED) ARCHITECT TO COORDINATE WITH CIVIL ENGINEER ON THE SITE PLAN. REFER TO DETAIL 2/A8.
24 PRE-FINISHED GALVANIZED STEEL DOWNSPOUT & COLLECTOR BOX. G.C TO COORDINATE CIVIL ENGINEERS TO CONFIRM IF DOWNSPOUTS ARE SPLASHING ON CONCRETE PAD OR TIED TO THE STORM SEWER LINE. REFER TO MECHANICAL DRAWINGS.
25 ALL BASE FLASHING TO MATCH ADJACENT MATERIAL COLORS.
26 HOSE BIB. G.C TO PAINT. COLOUR TO MATCH ADJACENT STUCCO COORDINATE EXACT LOCATION WITH G.C. REFER TO MECHANICAL DRAWINGS.
27 N/A.
28 TEAL (PANTONE #326 C) ALUMINUM SHUTTERS. SUPPLY & INSTALL BY SIGN COMPANY.
29 G.C TO PROVIDE CONCRETE CURB ALONG DRIVE-THRU LANE. CURB TO PROJECT 8" FROM FACE OF PANELS AND LENGTH OF CURB IS EXTENT OF FEATURE WALL.
30 N/A.
31 REAR EXIT DOOR. REFER TO POPEYES MASTER SCHEDULE.
32 WALL SCONCE SUPPLY AND INSTALL BY SIGN COMPANY.
33 METAL RAILING SUPPLIED AND INSTALLED BY G.C. ALL CANOPIES IN WALL SUPPORT BY G.C. REFER TO STRUCTURAL DRAWINGS.
34 VERTICAL SIMULATED ALUMINUM SLATS. REFER TO POPEYES MASTER SCHEDULE.
35 N/A.
36 CONCRETE SIDEWALK (BY G.C). REFER TO SITE PLAN.
37 NON ILLUMINATED 8" ALUMINUM FASCIA BAND. SUPPLY BY SIGN COMPANY AND INSTALLED BY G.C.
38 NEW EXTERIOR DOOR. COLOR: ROOT BEER. REFER TO POPEYES MASTER SCHEDULE.
39 EXTERIOR ROOF LADDER.

ISSUE TABLE

Table with columns: No., Date (mm/dd/yyyy), Description. Row 1: 01, 24.07.23, 6095 PROTOTYPE DOCUMENTS.

REVISIONS

Table with columns: No., Date, Description. Empty table.

DRAWINGS REVISED AS PER DESIGN BULLETIN

Table with columns: No., Date, Description. Empty table.

Table with columns: No., Date, Description. Empty table.

THIS DRAWING IS OWNED BY OR LICENSED FOR USE BY POPEYES LOUISIANA KITCHEN (OR ITS AFFILIATED OR RELATED COMPANIES) AND MAY NOT BE REPRODUCED, USED, DOWNLOADED, DISEMINATED, PUBLISHED, OR TRANSFERRED IN ANY FORM OR BY ANY MEANS, EXCEPT WITH THE PRIOR WRITTEN CONSENT OF POPEYES LOUISIANA KITCHEN. COPYRIGHT INFRINGEMENT IS A VIOLATION OF FEDERAL LAW SUBJECT TO CRIMINAL AND CIVIL PENALTIES.

THE CONTRACTOR IS TO VERIFY ALL DIMENSIONS AND CONDITIONS ON THE PROJECT AND TO REPORT ANY DISCREPANCIES TO THE POPEYES LOUISIANA KITCHEN REPRESENTATIVE PRIOR TO COMMENCING WORK. THESE DRAWINGS ARE NOT TO BE USED FOR CONSTRUCTION PURPOSES UNLESS INDICATED BY POPEYES LOUISIANA KITCHEN AS 'ISSUED FOR CONSTRUCTION'.

WARMAN ARCHITECTURE DESIGN
1735 SWIFT AVE.
NORTH KANSAS CITY, MISSOURI 64116
V. 816.474.2233 F. 816.474.1051

LOUISIANA KITCHEN logo with chicken icon and '72'.

POPEYES logo.

Store Type: US 2124 MIRROR PROTOTYPE 2124-21
Location: 97th Street & North Oak Trafficway, Kansas City, MO

Drawing Title: EXTERIOR ELEVATIONS

Table with columns: Drawn, Checked, Scale, Date, Project No., Drawing No. Values: KAW, Sept 04, 2024, 6095-24, A5.0



1 EAST ELEVATION
SCALE: 1/4" = 1'-0"

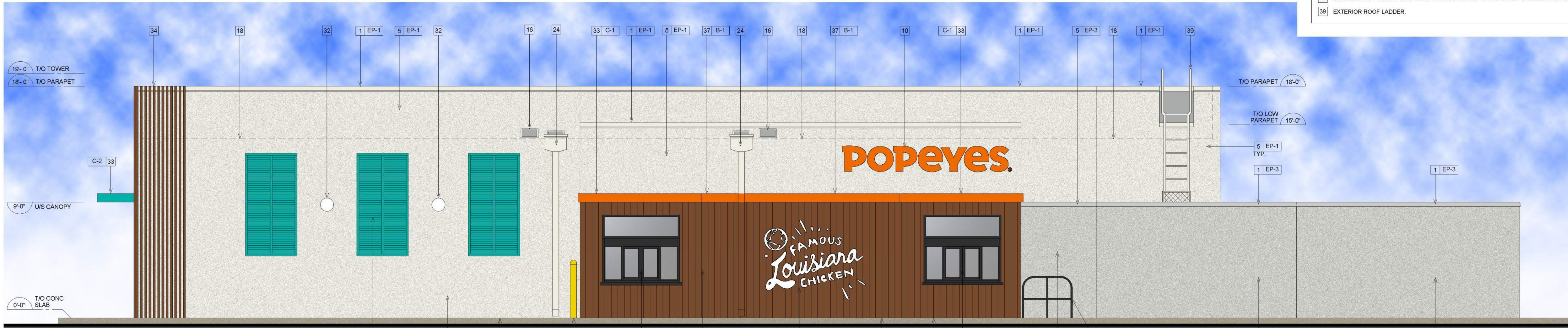

2 NORTH ELEVATION
SCALE: 1/4" = 1'-0"

EXTERIOR FINISH SCHEDULE

TAG	MATERIAL	APPLICATION	MANUFACTURER	PRODUCT	COLOR/FINISH	DIMENSION
FINISH MATERIALS						
EF-1	EXTERIOR WOOD SIDING	FRONT FACADE EXTERIOR WALLS	NICHIHA FIBER CEMENT	VINTAGE WOOD AWP 3030	CEDAR	17-7/8" H x 119 5/16" L
EB-1	BRICK (CLIP-SYSTEM)	FRONT OF BUILDING	NICHIHA FIBER CEMENT	VINTAGE BRICK	WHITE WASH (PAINT EP-1)	7 3/8" x 2 1/2" x 3/4"
EB-2	BRICK (CLIP-SYSTEM)	ACCENT TOWER BRICK	NICHIHA FIBER CEMENT	VINTAGE BRICK	ALEXANDRIA BLUFF	7 3/8" x 2 1/2" x 3/4"
EXTERIOR PAINTS						
EP-1	EXTERIOR PAINT	MAIN WALL SURFACE	BENJAMIN MOORE	ULTRA SPEC EXTERIOR LOW LUSTRE (N455)	OC-125 MOONLIGHT WHITE	
EP-2	EXTERIOR PAINT	BRICK TOWER PARAPET	BENJAMIN MOORE	ULTRA SPEC EXTERIOR LOW LUSTRE (N455)	2105-20 ROOT BEER CANDY	
EP-3	EXTERIOR PAINT	DUMPSTER WALLS, REAR DOOR	BENJAMIN MOORE	ULTRA SPEC EXTERIOR LOW LUSTRE (N455)	HC-170 STONINGTON GREY	
EP-4	METAL PAINT	BOLLARDS	BENJAMIN MOORE	COROTECH HIGH SOLIDS RAPID DRY ENAMEL	SAFETY YELLOW	
EP-5	METAL PAINT	DUMPSTER GATES AND PYLON POLE	BENJAMIN MOORE	COROTECH HIGH SOLIDS RAPID DRY ENAMEL	FACTORY FINISH BLACK	
EP-6	ANTI-GRAFFITI COAT	EXTERIOR WALLS	BENJAMIN MOORE	ALIPHATIC ACRYLIC URETHANE - GLOSS	V500-00 CLEAR	
EP-7	EXTERIOR PAINT	EXTERIOR WALLS	BENJAMIN MOORE	ULTRA SPEC EXTERIOR LOW LUSTRE (N455)	"TEAL" COLOR CODE TBD	
EXTERIOR MISC.						
B-1	DT BAND - METAL	DRIVE-THRU BAND	BY MANUFACTURER	BY MANUFACTURER	ORANGE, PANTONE #3564 C	
B-2	BAND - METAL	OVER STOREFRONT	BY MANUFACTURER	BY MANUFACTURER	TEAL, PANTONE #326 C	
C-1	CANOPY - METAL	DRIVE-THRU CANOPY	BY MANUFACTURER	BY MANUFACTURER	ORANGE, PANTONE #3564 C	
C-2	CANOPY - METAL	BUILDING CANOPIES	BY MANUFACTURER	BY MANUFACTURER	TEAL, PANTONE #326 C	
S-1	SHUTTERS	EXTERIOR WALLS REAR OF BUILDING	BY MANUFACTURER	BY MANUFACTURER	PROVIDED BY MANUFACTURER	
DP-1	DOOR	MAIN ENTRANCE DOORS	BY MANUFACTURER	BY MANUFACTURER	ORANGE, PANTONE #3564 C	

EXTERIOR ELEVATION NOTES

- PRE-FINISHED METAL CAP FLASHING CW/ DRIP.
- G.C. TO PROVIDE AND INSTALL DOUBLE LAYER OF REINFORCING MESH TO MIN. 2" ABOVE GRADE AT ALL EIFS LOCATIONS (TYP.) IN ORDER TO ATTAIN ABUSE RESISTANCE STUCCO SYSTEM.
- NICHIHA VINTAGEBRICK, COLOR: ALEXANDRIA BUFF. REFER TO POPEYES MASTER SCHEDULE.
- NICHIHA VINTAGEBRICK, COLOR: WHITE WASH. REFER TO POPEYES MASTER SCHEDULE.
- EIFS. REFER TO POPEYES MASTER SCHEDULE.
- PRE-FINISHED 'BLACK ANODIZED' ALUMINUM STOREFRONT SYSTEM WITH INSULATED GLAZING.
- EXPOSED FOUNDATION TO BE PARGED AND FREE OF IMPERFECTIONS.
- GAS UTILITY METER.
- REFER TO STRUCTURAL DRAWINGS FOR FOUNDATION WALL AND FOOTING DETAILS.
- INTERNALLY ILLUMINATED BUILDING SIGNAGE PROVIDED AND INSTALLED BY SIGN COMPANY. G.C. TO PROVIDE AND INSTALL 1/2" EXTERIOR GRADE PRESSURE TREATED PLYWOOD BACKING AND ALL FINAL ELECTRICAL CONNECTION. SIGN MANUFACTURER SHALL OBTAIN STRUCTURALLY SEALED DRAWINGS AND SIGNAGE PERMITS FROM THE CITY BASED ON LOCAL REQUIREMENTS. G.C. SHALL VERIFY ACTUAL LOCATION & SIZE OF SIGNS WITH SIGN MANUFACTURER'S APPROVED DRAWINGS AND COORDINATE LOCATIONS OF BLOCKING AND UTILITIES. G.C. TO COORDINATE WITH SIGN INSTALLER TO USE VHM DRILL BIT WHILE DRILLING FOR ELECTRICAL FEED LINES AND SIGNAGE FASTENERS. ALL ELEMENTS PROVIDED BY SIGNAGE FABRICATOR TO BE REVIEWED AND APPROVED BY POPEYES PRIOR TO PRODUCTION.
- NON-ILLUMINATED BUILDING SIGNAGE PROVIDED AND INSTALLED BY SIGN COMPANY. G.C. TO PROVIDE AND INSTALL 1/2" EXTERIOR GRADE PRESSURE TREATED PLYWOOD BACKING. SIGN MANUFACTURER SHALL OBTAIN STRUCTURALLY SEALED DRAWINGS AND SIGNAGE PERMITS FROM THE CITY BASED ON LOCAL REQUIREMENTS. G.C. SHALL VERIFY ACTUAL LOCATION & SIZE OF SIGNS WITH SIGN MANUFACTURER'S APPROVED DRAWINGS AND COORDINATE LOCATIONS OF BLOCKING AND UTILITIES. G.C. TO COORDINATE WITH SIGN INSTALLER TO USE VHM DRILL BIT WHILE DRILLING FOR ELECTRICAL FEED LINES AND SIGNAGE FASTENERS. ALL ELEMENTS PROVIDED BY SIGNAGE FABRICATOR TO BE REVIEWED AND APPROVED BY POPEYES PRIOR TO PRODUCTION.
- NICHIHA VINTAGE WOOD, COLOR: CEDAR. REFER TO POPEYES MASTER SCHEDULE.
- PROVIDE & INSTALL 6" DIAMETER STEEL PIPE BOLLARD TOP AT 4'-0" A.F.F. G.C. TO PAINT "SAFETY YELLOW". REFER TO POPEYES MASTER SCHEDULE.
- DRIVE-THRU WINDOW. REFER TO DRIVE-THRU WINDOW SCHEDULE ON SHEET A11.
- CMU ENCLOSURE WITH PLASTER APPLIED TO EXTERIOR OF ENCLOSURE WITH A SMOOTH CONTINUOUS SURFACE. PAINT PLASTER EP-3.
- OVERFLOW SCUPPER. FLOW LINE TO BE 2" (HOLD) ABOVE FLOW LINE OF ROOF SCUPPER.
- N/A.
- DASHED LINE INDICATES T/O OF ROOF BEHIND PARAPET.
- CT CABINET AND METER.
- LINE OF PARAPET WALLS BEYOND.
- GENERAL PURPOSE EXTERIOR LIGHTING FIXTURES.
- WALK-IN COOLER/FREEZER FINISH TO BE COMPLETED BY MANUFACTURER.
- METAL RAILING SUPPLIED AND INSTALLED BY G.C. (ONLY IF REQUIRED) ARCHITECT TO COORDINATE WITH CIVIL ENGINEER ON THE SITE PLAN. REFER TO DETAIL 2/A8.
- PRE-FINISHED GALVANIZED STEEL DOWNSPOUT & COLLECTOR BOX. G.C. TO COORDINATE CIVIL ENGINEERS TO CONFIRM IF DOWNSPOUTS ARE SPLASHING ON CONCRETE PAD OR TIED TO THE STORM SEWER LINE. REFER TO MECHANICAL DRAWINGS.
- ALL BASE FLASHING TO MATCH ADJACENT MATERIAL COLORS.
- HOSE BIB. G.C. TO PAINT. COLOUR TO MATCH ADJACENT STUCCO COORDINATE EXACT LOCATION WITH G.C. REFER TO MECHANICAL DRAWINGS.
- N/A.
- TEAL (PANTONE #326 C) ALUMINUM SHUTTERS, SUPPLY & INSTALL BY SIGN COMPANY.
- G.C. TO PROVIDE CONCRETE CURB ALONG DRIVE-THRU LANE. CURB TO PROJECT 8" FROM FACE OF PANELS AND LENGTH OF CURB IS EXTENT OF FEATURE WALL.
- N/A.
- REAR EXIT DOOR. REFER TO POPEYES MASTER SCHEDULE.
- WALL SCONCE SUPPLY AND INSTALL BY SIGN COMPANY.
- OPEN BOTTOM ALUMINUM CANOPY WITH DOWNLIGHT LED LIGHT FIXTURE. SUPPLY BY SIGN COMPANY AND INSTALL BY G.C. ALL CANOPIES IN WALL SUPPORT BY G.C. REFER TO STRUCTURAL DRAWINGS.
- VERTICAL SIMULATED ALUMINUM SLATS. REFER TO POPEYES MASTER SCHEDULE.
- N/A.
- CONCRETE SIDEWALK (BY G.C.). REFER TO SITE PLAN.
- NON ILLUMINATED 6" ALUMINUM FASCIA BAND. SUPPLY BY SIGN COMPANY AND INSTALLED BY G.C.
- NEW EXTERIOR DOOR. COLOR: ROOT BEER. REFER TO POPEYES MASTER SCHEDULE.
- EXTERIOR ROOF LADDER.

ISSUE TABLE

No.	Date (mm/dd/yy)	Description
01	24.07.23	6095 PROTOTYPE DOCUMENTS

REVISIONS

No.	Date	Description
-----	------	-------------

DRAWINGS REVISED AS PER DESIGN BULLETIN

No.	Date	Description
-----	------	-------------

THIS DRAWING IS OWNED BY OR LICENSED FOR USE BY POPEYES LOUISIANA KITCHEN (OR ITS AFFILIATED OR RELATED COMPANIES) AND MAY NOT BE REPRODUCED, USED, DOWNLOADED, DISEMINATED, PUBLISHED, OR TRANSFERRED IN ANY FORM OR BY ANY MEANS, EXCEPT WITH THE PRIOR WRITTEN CONSENT OF POPEYES LOUISIANA KITCHEN. COPYRIGHT INFRINGEMENT IS A VIOLATION OF FEDERAL LAW SUBJECT TO CRIMINAL AND CIVIL PENALTIES.

THE CONTRACTOR IS TO VERIFY ALL DIMENSIONS AND CONDITIONS ON THE PROJECT AND TO REPORT ANY DISCREPANCIES TO THE POPEYES LOUISIANA KITCHEN REPRESENTATIVE PRIOR TO COMMENCING WORK. THESE DRAWINGS ARE NOT TO BE USED FOR CONSTRUCTION PURPOSES UNLESS INDICATED BY POPEYES LOUISIANA KITCHEN AS ISSUED FOR CONSTRUCTION.

GENERAL NOTES

- SEALANT / CAULKING AROUND DOOR / WINDOW FRAMES. COLOUR: TO MATCH WINDOW / DOOR FRAMES.
- THE CONTRACTOR SHALL BECOME FAMILIAR WITH AND FOLLOW ALL DRAWINGS AND SPECIFICATIONS.

SYMBOL LEGEND

- 1 NOTE REFERENCE. REFER TO ELEVATION NOTES
- FNR FINISH TYPE

NOTE

ALL SIGNAGE UNDER SEPARATE PERMIT

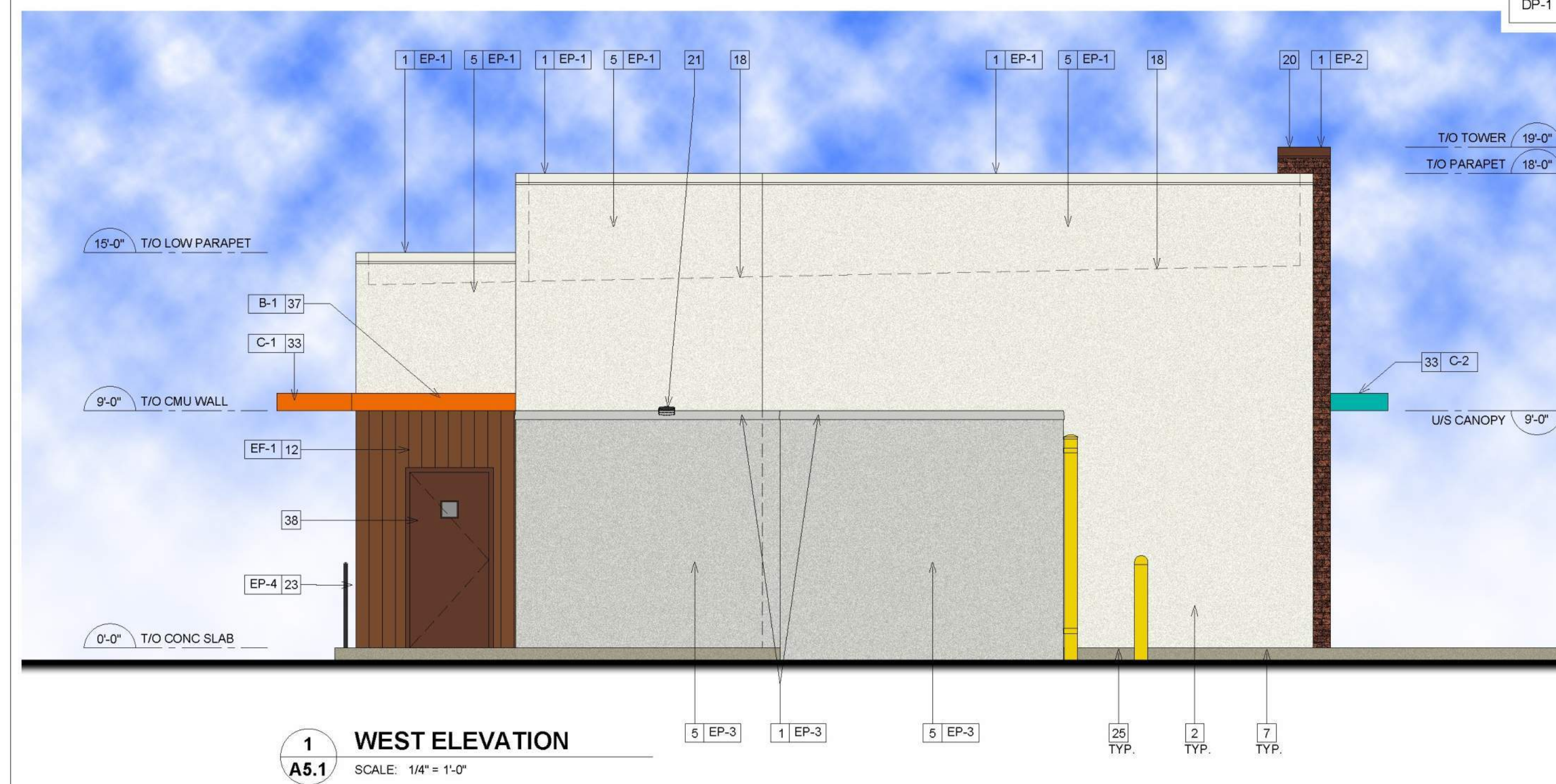

1 WEST ELEVATION
A5.1 SCALE: 1/4" = 1'-0"

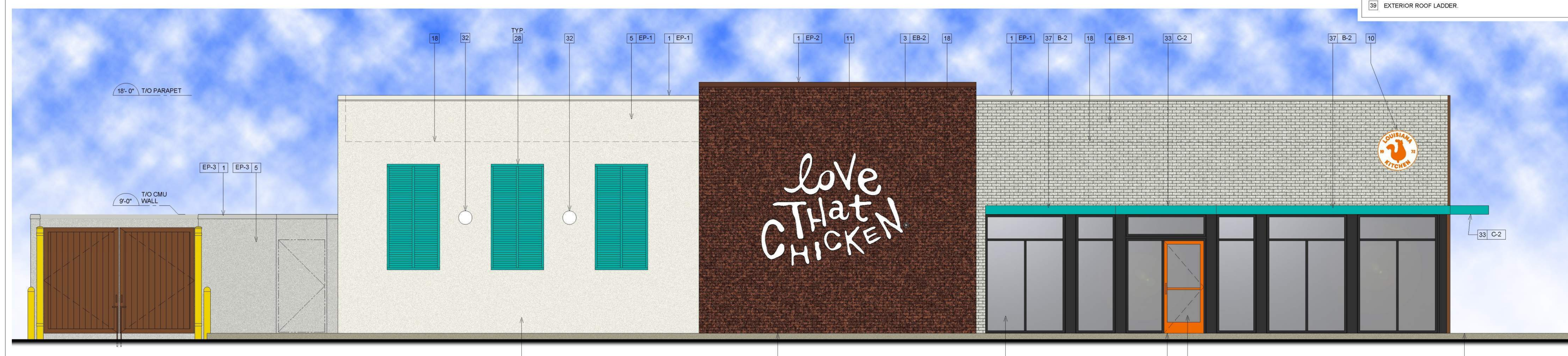

2 SOUTH ELEVATION
A5.1 SCALE: 1/4" = 1'-0"

Company Logo



Project



POPEYES

Store Type
US 2124 MIRROR PROTOTYPE 2124-21

Location
97th Street & North Oak Trafficway
Kansas City, MO

Drawing Title
EXTERIOR ELEVATIONS

Drawn
Checked
KAW

Scale
Date
Sept 04, 2024

Project No.
Drawing No.
6095-24 A5.1

Warranty Information:
 1.) 10 Year Warranty on GE 7100K LED Lighting
 2.) 5 Year Warranty on GE Power Supplies

Drive Thru Order Canopy

Proposed
 Insert Item Code

DESIGN INTENT ONLY
 Engineering Required to
 Determine Actual Production
 & Installation Requirements

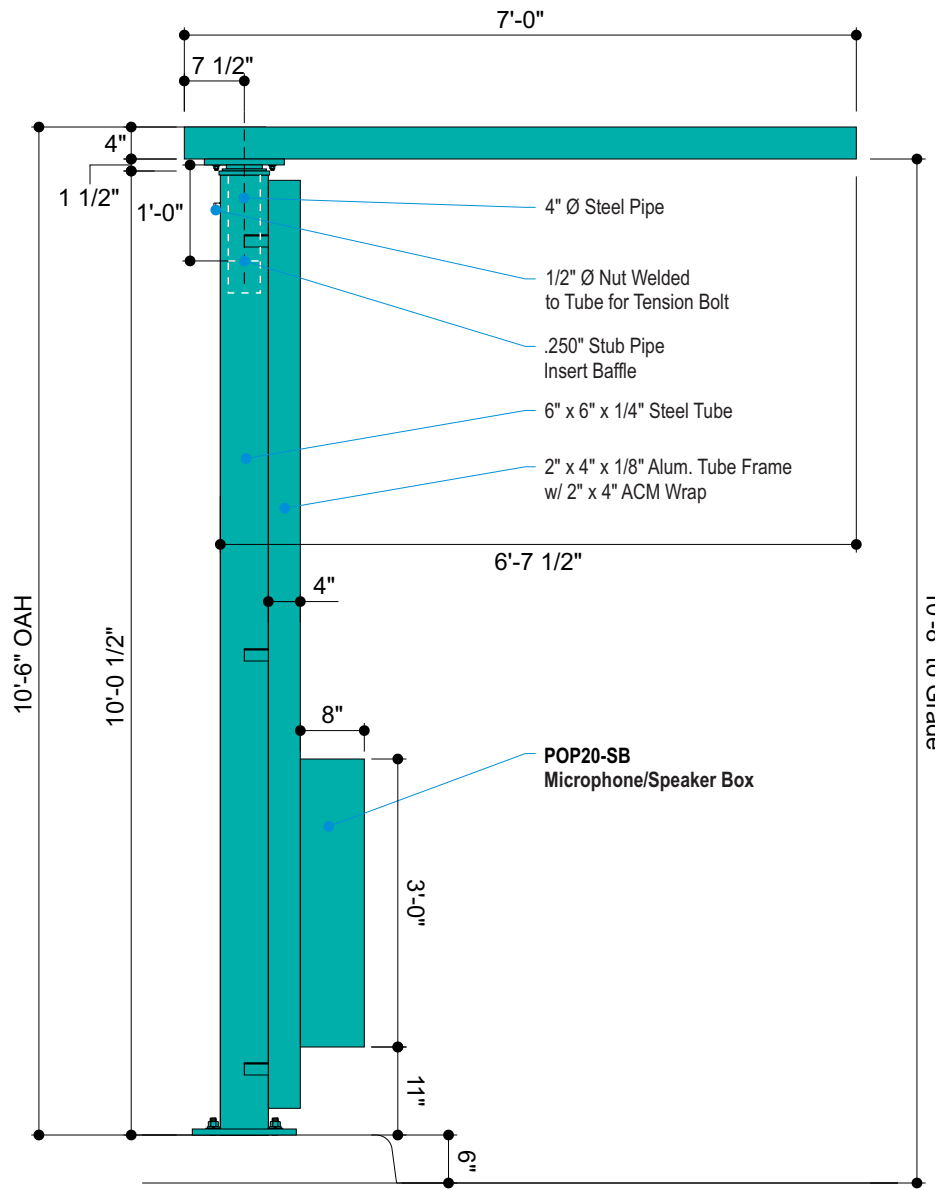

Front (Entrance) View
 Scale: 1/2"=1'-0"

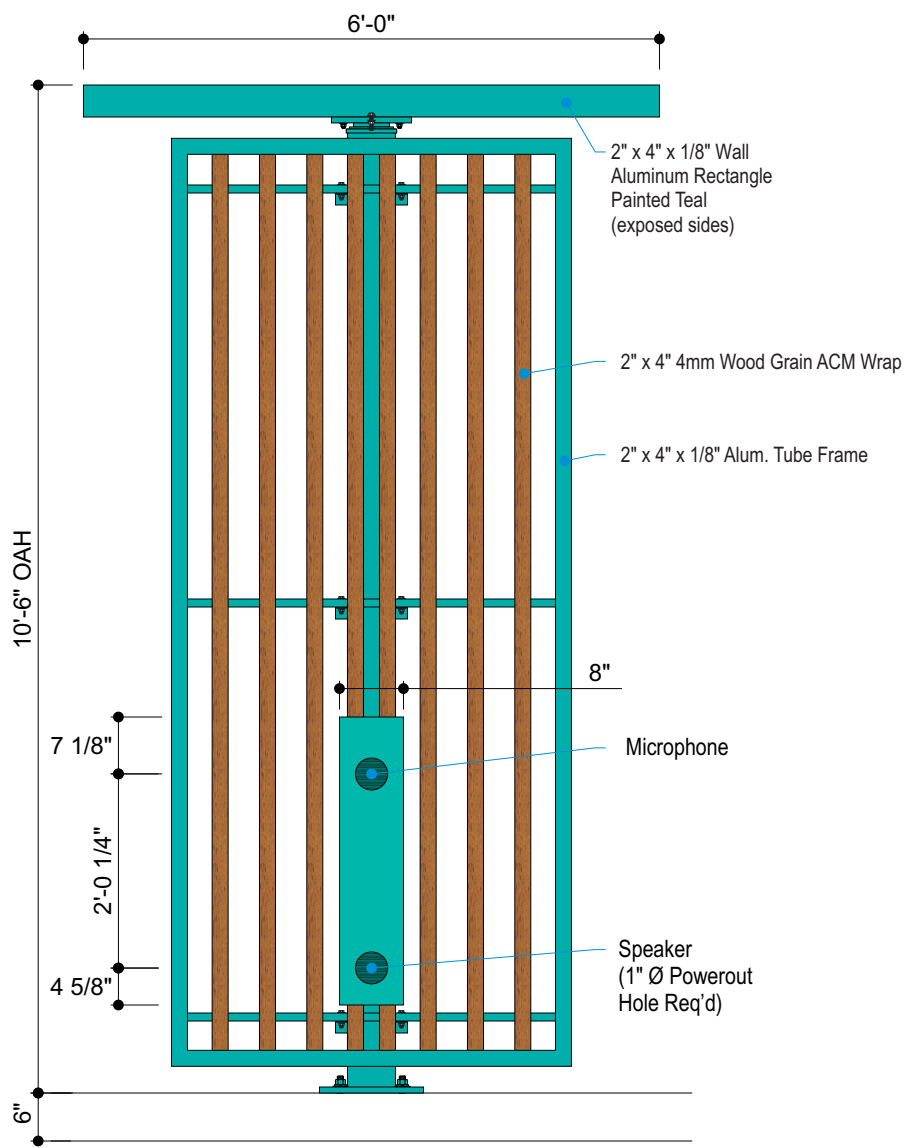

Side View
 Scale: 1/2"=1'-0"

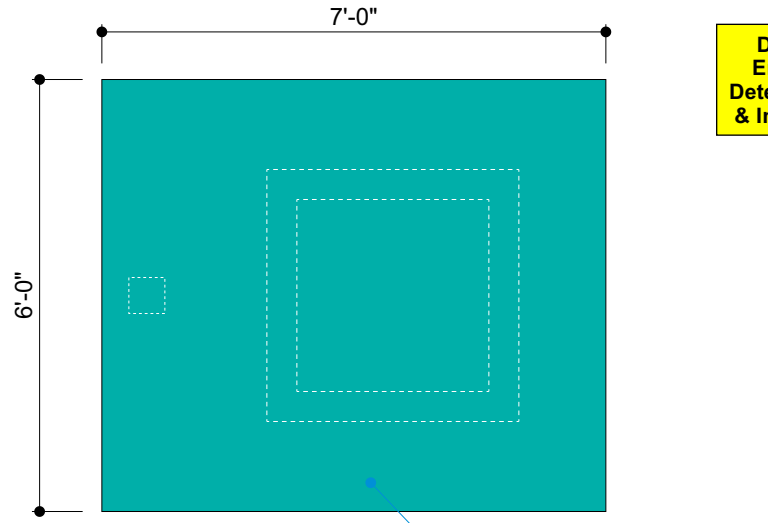

Top View
 Scale: 3/8"=1'-0"

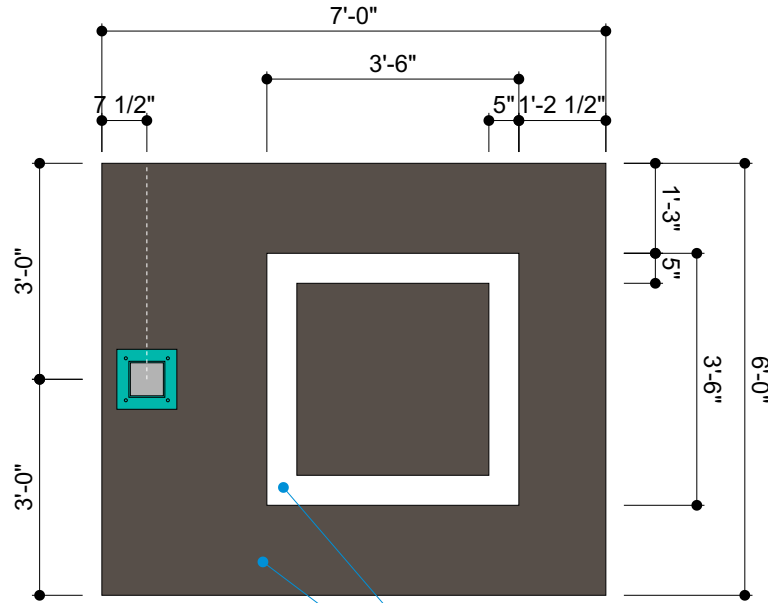

Bottom View
 Scale: 3/8"=1'-0"

Color Specifications

- Reynobond Duragloss 5000 French Walnut

Paint Specifications

- Paint to Match Pantone 326C - Teal
- BM CC-542 Willow

All paint finishes to be Satin unless otherwise specified

General Specifications:

Canopy: Fabricated Aluminum & ACM Structure w/ Steel Tube Support.

Electrical: Actual Number of Circuits to be Determined by Licensed Electrical Contractor (1) 20 AMP Circuit, 120 Volts - All Wiring Shall be 12 GA

Quantity: (1) ONE

Allen Industries FILE NUMBER: E212503

Electric Sign Complies with **UL48**

THIS SIGN IS INTENDED TO BE INSTALLED IN ACCORDANCE WITH THE REQUIREMENTS OF ARTICLE 600 OF THE NATIONAL ELECTRICAL CODE AND/OR OTHER APPLICABLE LOCAL CODES. THIS INCLUDES PROPER GROUNDING AND BONDING OF THE SIGN.

GROUNDING ELECTRICAL CONNECTIONS

Allen Industries
 YOUR BRAND AT ITS BEST™
 1-800-967-2553
 www.allenindustries.com

Copyright © 2021 Allen Industries, Inc. This is an original, unpublished drawing, created by Allen Industries, Inc. This drawing is submitted to you in confidence for your use solely in connection with the project being planned for you by Allen Industries, Inc. and is not to be shown to anyone outside your organization, nor used, reproduced, copied or exhibited in any fashion whatsoever. The designs shown on the drawing (except for any registered trademarks that may belong to a client of Allen Industries, Inc.) remain the property of Allen Industries, Inc.

Client: POPEYES #
Address: "

Issue Date: 05/23/22
Page #: 14 of 21
File Name: Popeyes_2100 Series Signage Reference Book
Sales: House **Design:** ECW **PM:** -

#	Date	Description	Initial
1	-	-	-
2	-	-	-
3	-	-	-
4	-	-	-
5	-	-	-
6	-	-	-

Client Review Status
 Allen Industries, Inc. requires that an approved drawing be obtained from the client prior to any production release or production release revision.

Client Signature: _____ **Approval Date:** _____

Public Meeting Notice

Please join _____

for a meeting about _____

case number _____

proposed for the following address:

Meeting Date:

Meeting Time:

Meeting Location:

Project Description:

If you have any questions, please contact:

Name:

Phone:

Email:

You are receiving this notice in accordance with city code that requires a public meeting with neighborhoods for certain types of development projects. You can read more about the process requirements at kcmo.gov/publicengagement



If you would like further information on this proposed project, please visit the city's planning and permitting system, Compass KC, at Compasskc.kcmo.org. You may search by project type and address/case number to find project details.

Sincerely,

Date: November 14, 2024

Meeting Date: November 13, 6:00 PM

Location of Meeting: Virtual Held Via Zoom

Project: Popeye’s Louisiana Kitchen

Project/File No.: #240374

Neighborhood Attendees: See neighborhood attendees on last sheet

Development Team: Daniel Finn – Phelps Engineering
Kathy Warman – Warman Architecture
Chad Trealout – Warman Architecture
Felix Zamikovsky – CSM Group

-
1. Daniel Finn welcomed the attendees via zoom. He explained where the project was currently within the KCMO planning review and approval process. He explained the upcoming planning commission meeting date. He then asked all attendees to provide their names and addresses within the zoom chat in order to provide the City the required attendance information.
 2. Daniel Finn explained the project going through the civil documents. This included an overview of the site layout, grading plan, utility plan, and landscape plan.
 3. Kathy Warman gave an overview of the proposed building design and elevations.
 4. At this time, we opened the meeting up for questions from the public.
 5. Question/Comment: What about the stop light we were promised at 98th terrace.
 - a. We explained that this project did not require a traffic study as commercial use was previously approved. We explained that a signal was not shown on the previously approved development plan and we have not been told of any plans for a signal during our discussions with staff. We let the neighbor know that we would email the planner, with the neighbor included in the email the following day, so that staff could provide more feedback on a future signal.

6. Question/Comment: Shrubs and ornamental trees will not provide any screening. How can you address the illumination of the building at night. We already see the red qt canopy and the blue culvers lights from our residence.
 - a. It was explained the landscape screening was robust with a continuous row of shrubs around the west, north, and east side of the drive thru. It was explained that the photometric plan meets all City requirements for lighting and all building lighting is required to have full cutoff fixtures.
7. Question/Comment: What are the hours, how late will this be open?
 - a. The typical hours of operation are 10/11 AM to 9/10 PM.
8. Question/Comment: We are bombarded with drive thru lanes. why are double drive thru's necessary. Idling cars are what we see all day long with culvers.
 - a. It was explained that this post covid world has created the need for more drive thru uses so business owners are confident that they can operate in the event of another pandemic.
9. Question/Comment: These cars will still be screened. not enough screening. would you willingly live across from a fast food restaurant. How tall are the hedges.
 - a. It was explained that the screening is meeting the City's ordinance and the plantings must be 3 ft minimum height at the end of the first growing season.
10. Question/Comment: Where will construction traffic enter / park. There is concern of construction vehicles parking on 99th Street as well as construction traffic damaging the public street. There is concern the shrubs will not screen large SUVs.
 - a. It was explained that construction traffic and erosion control drawings indicating contractor entrance and laydown areas would be provided at the time of building permit. This would need to be approved by the City and follow all their regulations.
11. Question/Comment: The neighbor said they will likely have more questions but will raise those with the Planning Commission.
12. Meeting concluded at around 6:25 pm

**Neighborhood Attendees
(names and addresses provided via zoom)**

The Allen's

404 NE 97th Ter, KCMO

KANSAS CITY MISSOURI
City Council
Approved without Conditions
Ord. No: **220235** Date: **3/24/2022**
Diane Binkckley
Diane Binkckley, ACP
Secretary of the City Plan Commission

KANSAS CITY MISSOURI
City Council
Approved without Conditions
Ord. No: **240510** Date: **6/27/2024**
Diane Binkckley
Diane Binkckley, ACP
Secretary of the City Plan Commission

97th & N. Oak City Design Standards

Kansas City, MO



Table of Contents

Purpose of These Standards2
 Acknowledgements.....2
 Design Team and Contact Information2
 Tenant Design Review.....3
 Architectural Standards4
 Major Elements.....5
 Building Materials & Colors6
 Equipment Screening and Outdoor Display and Sales.....7
 Landscape Standards9
 Site Furnishings11
 Irrigation Standards & Signage Standards12
 Signs Not Permitted13

Purpose of These Standards

The 97th and N. Oak Design Standards serve to provide a structure for future developers and property owners to follow as they prepare to start and continue to work through the development process. These standards are established to help achieve a desired aesthetic for 97th and N. Oak. They are in place to ensure that development within 97th and N. Oak begins with a standard that continues throughout the years to provide and maintain a cohesive appearance throughout the development.

The 97th and N Oak Design Standards book serves as a central resource for the City of Kansas City as well as developers, providing information specific to the various Property Owners and Tenants throughout 97th and N. Oak. In addition, the 97th and N. Oak Design Standards book provides information to guide developers through general site planning, architectural and landscape design, sustainability, lighting, storm water management, and signage. These items are further supplemented by the City of Kansas City, MO Municipal Codes and Ordinances.

Acknowledgements

Design Team and Contact Information

Elevate Property Advisors 7121 W. 79 th Street Overland Park, KS 66204 PH: 913.914.7010	Klover Architects, Inc. 8813 Penrose Lane Suite 400 Lenexa, KS 66219 PH: 913.649.8181	Olsson 7301 W. 133rd Street Suite 200 Overland Park, KS 66213 PH: 913.381.1170
---	---	--

Tenant Design Review

A tenant review is primarily described as “the coordination and verification of Tenant drawings for compliance with 97th and N. Oak Development criteria and requirements, on behalf of the Landlord.”

We may assist a tenant through the process; however, our responsibilities are to the Landlord.

Typical Summary of actions:

- 1) Preliminary Tenant drawings for review – KAI performs review within 10 working days (unless specifically requested earlier by the Landlord) and sends back to tenant with marked-up drawings, TR form, and all parties copied. **Note:** If not enough information is received for a reasonable review; simply call the tenant or reject, due to a lack of information. Record all actions on your status report.
- 2) Final Tenant Drawings for review – If applicable, KAI first sends one set of drawings (without our comments) along with a transmittal from the tenant to the Landlord MEP engineer for their review (as soon as we have received tenant drawings and deemed the package complete enough to review). KAI then performs a review based on the criteria and misc. lease requirements within 10 working days. The review is then sent back to tenant with marked-up drawings, TR form, and all parties copied.
- 3) Sign Shop Drawing – Each tenant needs to submit a Sign Shop drawing for review. A sign typically cannot be reviewed without a storefront design. (i.e.-tenant wants to change signs on an existing store and sends a sign shop drawing. We still need to see a sign drawing showing it within the context of the storefront). Provide technical info on the sign to know how specifically it is being built, materials, size, projection from mounting surface, raceway conditions, etc. then you do not have enough info.

Please note that with the ever-changing new finish materials and construction methods, some submitted new materials or design concepts might not be addressed in the Design Standards. This does not mean that these materials are unacceptable. Based on an individual review basis, some items or materials may be acceptable if deemed appropriate for the intended use or design.

Tenant Approval types

There are four (4) designations that can be given to a tenant review. Please reference the following types of approvals and their descriptions:

Approved (A) – The drawings are accurate (correct lease space configuration, etc.). The store documents and finished both comply with the design criteria and the store design meets the design standards.

Approved as Noted (AAN) – same as above, but there may be minor items to be corrected or that does not meet the design standards. **Note: KAI comments must be incorporated into the final approved store construction for Landlord’s final occupancy inspection to be approved. The Tenant Coordinator will police the construction site to ensure these outstanding comments are incorporated into the work.**

Approved as Noted, Revise & Resubmit (AAN-RR) – same as above but there may be minor items to be corrected or that does not meet design standards. The comment may not prevent the commencement of construction but may be substantial enough to require it to be recorded in the tenant construction documents. This is primarily reserved for tenants that the Landlord wants to get approval for to start construction immediately, but there may be a few items yet to be modified, submitted, and approved.

Return for Corrections (RFC) – These are a rejection of plans due to incomplete documents, non-compliance with the tenant criteria or both.

Coordination with Landlord

The Tenant Construction Coordinator is Klover Architects, Inc. All tenant submissions shall be submitted in digital PDF format via email to Patrick Reuter, patrick.reuter@klover.net with Landlord CC’d.

Architectural Standards

Summary

The primary purpose of the architectural design guidelines is to provide a framework to ensure the quality of the buildings site design proposed for the development. These design standards are set forth as a baseline for all development within the site as well as all tenants.

These guidelines are to guide the quality of the materials selected, the proportion of the building massing, the definition of architectural elements, and to encourage high design standards.

Accessibility

This document does not specifically address issues of accessibility or universal design as the local building codes and standards will dictate the requirements for any given type of development. However, it is important that all projects consider the need for accessibility and universal design beyond that which is required by code. Exemplary projects within any given district will consider the needs of all users and provide design solutions that provide every user with the same experience regardless of physical capability.

Permitted Uses

All uses allowed per City of Kansas City, Missouri zoning ordinances for MPD zoning districts.

Zoning Regulations

All proposed building development site planning and building designs must adhere to the Landlord and City of Kansas City, Missouri Design Standards.



Major Elements

Building Entry

Vestibule entries are encouraged to have a defining architectural feature (such as roof pitch or canopies).

Fenestration

A minimum of 30% of street facing façade shall be fenestration.

Maximize buildings visual transparency.

Windows used for displays should not be covered with signage graphics except as permitted by the sign criteria.

Awnings & Canopies

Awnings and canopies are to be durable and UV stable material.

Awnings and canopies may project over the sidewalk with a minimum clear height of 8'-0".

Mechanical Equipment

At the ground level: outdoor mechanical, electrical and communication equipment shall be located behind the building with Architectural compatible screened material from any public way and/or vehicular or pedestrian street.

At the roof level: outdoor mechanical, electrical and communication equipment shall be located within the building massing or at the highest level of the building with no projection above the lowest parapet. Note all roof top equipment shall be fully screened from public view.

Loading docks, trash dumpsters, utility meters should be in an inconspicuous area and screened. The screening shall be incorporated into the overall design of the building.

Walls or landscaping should be the primary means to hide utilities and where permitted by utilities; any visible equipment is to be painted to blend with building architecture.

Architectural Image & Character

Franchise architecture should be adapted to meet the intent of the guideline.

Architectural design shall create harmony thru use of differing texture, material shadow lines and contrasting shapes to create visual interest.

Use of traditional materials and colors shall be consistent throughout the development to provide continuity.

Use of building material colors, façade design and roof lines shall be consistent on all sides.

Building Mass & Roof Forms

No long blank walls are permitted, and the walls shall be articulated both horizontally and vertically using projections, windows, canopies, bases and vertical wall elements and projections.

Roof

While flat roof may be the primary roof form in the retail district, a pitched roof used to reinforce the retailer's branding may be allowed. It is also acceptable (encouraged) that vestibule entries have a defining architectural feature (such as roof pitch or canopies).

Streetscape

Pedestrian Access

Frontal approach sidewalk to main entry shall be no less than 7'-0" wide, which may also include landscaping so long as the walkable surface of the sidewalk is no less than 6'-0" wide.

Wall Articulations & Projections

Locate activity generating and vibrant program along the perimeter and maximize visual transparency. There shall be no blank, unarticulated walls exceeding a building bay. Building bays shall generally not exceed 30'-40' or a reasonable pattern or rhythm that is appropriate to the size of the

building. Further subdivision of bays is encouraged - e.g., horizontal, vertical datum lines. Façade bays may be delineated by the following scaling elements:

- Recesses
- Reveals
- Continuous projections
- Diversity in material
- Change in module rhythm
- Shadow trim



Roof

Flat Roof

Canopy

Canopy is 8'-0" or taller above walkway

Pedestrian Façade

Main Entrance located along the street façade

Transparent Entrance

Entry is transparent and invites customers into the business

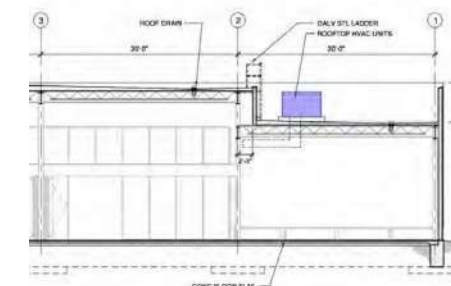

Mechanical Equipment

Roof level equipment shall be integrated, not visible



Windows

Street facing façade windows. Are encouraged

Transparent Entrance

Entry transparent glass

Pedestrian Access

10'-0" or wider side approach walkway

Building Materials & Colors

Materials Allowed

- Laminated wood (timber) and steel
- Architectural metal panel, fiber cement siding and panel (pre-finished)
- Architectural grade concrete, precast, or cast stone
- Glazing (storefront, curtain wall, windows)
- Stone
- Fired clay brick with a veneer depth of at least 3"
- Stucco
- Tile
- Standard Concrete or split block

Prohibited Materials

- Vinyl
- Fiberboard
- Non-architectural grade concrete
- Asphalt shingles (except for premium grade laminate style)

Lighting

Refer to lighting guidelines for additional requirements.

Utilize energy efficient light fixtures.

Exterior Building Lighting

Provide lighting to illuminate the entries, drop off canopy, outdoor spaces, parking entry and other walking surfaces.

Non-recessed types of light fixtures are to conform to the building design.

Lamps shall be of the same color temperatures



Transparent Entrance
Entry has transparent glass.



Transparent Entrance
Entry has transparent glass.



Canopy
Canopy is 10'-0" or higher above walkway

Transparent Entrance
Entry accent element.



Canopy
Canopy is 8'-0" or higher Above walkway

Windows
Street facing façade windows are encouraged



Equipment Screening and Outdoor Display and Sales

Outdoor Storage and Loading docks

Outdoor storage of any products, materials, debris, garbage, carts, or equipment of any kind is prohibited except as provided herein. All loading docks and receiving areas shall be located behind or side of the principal structures screened from view of all public and private streets and adjoining properties through a combination of screen walls, fences, and landscaping.

Trash, Grease, and Recycling Containers

All trash, grease, and recycling containers and dumpsters must be fully contained within a building or otherwise confined within a walled permanent enclosure with opaque gates. Said enclosures must be either incorporated as part of or located behind the main structure in an inconspicuous area and be of sufficient height to completely screen from view the containers. The enclosure and gates must be of durable materials that match the finish materials of the primary structure. Wood or composite material fencing is not an acceptable enclosure material except for the enclosure doors or gates. Landscaping should be added around the enclosure to soften its visual impact.

Back-up Power Generators, Ground-Mounted HVAC Equipment, Chillers, Solar Equipment, Towers, & Satellite Dishes

All backup power generators and ground-mounted HVAC equipment, including chillers, must be fully screened from view of public and private streets and adjoining properties. Screening shall be accomplished by a combination of screen walls and landscaping. Said equipment should be located behind the principal structures in areas to minimize the noise impact on adjoining properties. All equipment must be designed, enclosed, and/or muffled to produce minimal noise and shall comply with the City's noise control regulations.

Any solar collectors or photovoltaic panels shall not be visible from any public street, must be incorporated into the roof structure of an approved principal structure, and shall protrude no further than four (4) inches from the roof surface.

Communication towers and wind turbines are prohibited within 97th and N. Oak. Satellite dishes 24 inches in diameter and smaller should be located so not to be visible from a public or private street. All other satellite dishes must be completely screened from view.

Utility Meters and exposed utility conduits, pipes, and cables

Utility meters shall be in an inconspicuous area and screened from view with a combination of screen walls and landscaping. All utility conduits, pipes, cables, and roof access ladders shall be fully concealed within the structure.

Public and Private Utilities and Easements:

When practical, all public utility easements should be located along the rear of properties and outside of any required buffer parks so not to limit the ability to plant and maintain landscaping, especially along the street frontage. Above ground utility boxes, transformers, and equipment should also be located in the rear of properties and behind the principal structures to minimize their visual impact. When possible, transformers should be enclosed within the trash screen walls and landscaping, including ornamental grasses, should be planted around these structures-subject to any required safety clearances.



Lighting Standards

Design Guidelines

- Required lamps- all lamps shall be LED or others with similar qualities to conserve energy, reduce glare, and provide for improved color correct vision. Lamps for drives and parking fixtures shall maintain a color temperature range between 4,000 and 5,000 Kelvin. Lamps for pedestrian scale fixtures, including bollards and wall lighting, shall maintain a color temperature range between 3,500 and 4,000 Kelvin.
- Required Exterior Lighting Fixtures- all exterior lighting fixtures shall be full cut-offs. No portion of the lamp, lens, or diffuser shall be visible from the side or top of any shield, or otherwise protrude from the bottom of the shield. No exterior lighting fixture shall emit light at or above a horizontal plane that runs through the lowest point of the shield.
- Note: all individual tenant pad sites or developments are to adhere to the overall lighting standards stipulated in this section.

Site and Parking Lot Lighting

- The mounting height for lighting fixtures shall not exceed (33) thirty-three feet from grade to the top of the lighting fixture.
design shall incorporate an average/minimum uniformity ratio of 5:1.
- The maximum horizontal foot-candle measurement at any property line shall be two foot-candles. The maximum maintained vertical foot-candle at any adjoining property line shall be two foot-candles, as measured at five feet above grade.
- The maximum average-maintained foot-candles for a parking lot lighting fixture shall be three foot-candles.
- The maximum lighting level for a parking lot lighting fixture shall be ten foot-candles. Parking lot lighting



Roadway and Parking Fixture

Commercial and Industrial

Architectural and Decorative Lighting

- Limited building-mounted lighting may be used to highlight specific architectural features or primary customer or building entrances. Floodlights are only permitted provided all light emitted is contained by the building or by an eave or protruding structure.
- Lighting fixtures shall be located, aimed, and shielded to minimize the glare that is emitted on objects other than a building's façade or landscape walls.
- Building-mounted neon lighting may only be used when the lighting is recessed or contained inside a cap or architectural reveal.
- An exterior lighting fixture that emits less than 1800 lumens shall not be required to be a full cut-off fixture, provided that the lamp itself creates no glare or has an opaque covering.

Canopy Lighting

- The average maintained foot-candles under a canopy shall be twenty (20) foot-candles. Areas outside the canopy shall be regulated by the guidelines and standards outlined above. Permissible fixtures for canopy lighting include:
 - Recessed fixtures that incorporate a lens cover that is either recessed or flush with the bottom surface of the canopy.
 - Indirect lighting where light is emitted upward and then reflected down from the underside of the canopy. Such fixtures shall be shielded to ensure that no light is emitted at or above a horizontal plane that runs through the lowest point of the canopy.
- Landscape Accent Lighting
 - Low level ground mounted landscape lighting fixtures should be placed a minimum of twelve feet from the back of curb line of a travel way.
 - Lighting fixtures shall be located, aimed, and shielded to minimize the glare that is emitted on objects

Schedule									
Symbol	Label	Quantity	Manufacturer	Catalog Number	Description	Number Lamps	Lumens Per Lamp	Light Loss Factor	Wattage
	P3	12	LSI INDUSTRIES, INC.	SLM-LED-18L-SIL-3-40-70CRI-IL		1	12554	0.9	135
	P4	6	LSI INDUSTRIES, INC.	SLM-LED-18L-SIL-FT-40-70CRI-IL		1	12045	0.9	135

Statistics						
Description	Symbol	Avg	Max	Min	Max/Min	Avg/Min
LOT 1		1.9 fc	3.6 fc	0.2 fc	18.0:1	9.5:1
LOT 2		1.7 fc	3.1 fc	0.2 fc	15.5:1	8.5:1
LOT 3		1.5 fc	3.1 fc	0.2 fc	15.5:1	7.5:1
LOT 4		1.4 fc	3.0 fc	0.2 fc	15.0:1	7.0:1
LOT 5		1.3 fc	2.9 fc	0.2 fc	14.5:1	6.5:1

Landscape Standards

Landscape Intent/Goal(s)

All Landscape and Irrigation improvements shall meet the requirements established by the City of Kansas City, Missouri Landscape Ordinance.

Landscape Master Plan

The right landscape master plan shall be used to understand the overall scope of landscape including tree quantities and distribution of planting beds and sod.

Landscape General Parameters

All landscape materials and construction shall meet the standards set forth by the city of Kansas City, Missouri and American Standards for Nursery Stock (**ANSI Z60.1**).

- **City Standards**

- Kansas City, Missouri <https://library.municode.com> including landscape requirements that are reflected in the approved overall Preliminary Development Plan. These requirements, including minimum tree quantities are reflected in the individual lots as shown in the above landscape concept plan. Maintaining the minimum number of trees per lot (as shown in the approved preliminary development plan) is required to meet the overall development minimum tree requirements.
- Additional requirements such as parking lot screening, site perimeter landscape and parking lot landscape are required for each lot.

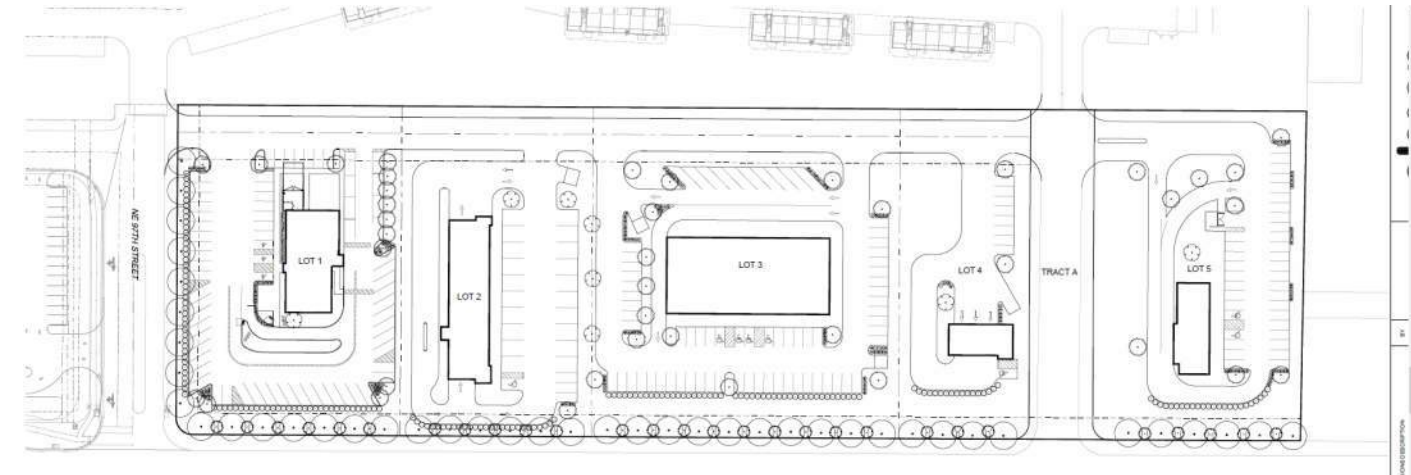

TABLE 3B - LANDSCAPE SCHEDULE

88-425 LANDSCAPE SCHEDULE	SYMBOL
88-425-03 STREET TREES	●
88-425-04 GENERAL	⊙
88-425-05 PERIMETER VEHICULAR USE AREA	⊕
- ADJACENT TO STREETS	
BUFFER WIDTH	10'+
TREES	⊙
SHRUBS/WALL/BERM	⊗
-ADJACENT TO RES. ZONES	
BUFFER WIDTH	N/A
SHRUBS/BERM/FENCE/WALL	N/A
88-425-06 INTERIOR VEHICULAR USE AREA	
INTERIOR AREA	
TREES	⊙
SHRUBS	⊕
88-425-07 PARKING GARAGE SCREENING	N/A
88-425-08 MECHANICAL/UTILITY EQUIPMENT SCREENING	3'+ EVERGREEN SHRUB SCREEN
88-425-09 OUTDOOR USE SCREENING	N/A

TABLE 3 - LANDSCAPE REQUIREMENTS

88-425 LANDSCAPE REQUIREMENTS	REQUIRED	PROPOSED	ALTERNATIVE REQUESTED?	APPROVED
88-425-03 STREET TREES	42	42	NO	N/A
88-425-04 GENERAL	8	8	NO	
88-425-05 PERIMETER VEHICULAR USE AREA				
- ADJACENT TO STREETS				
BUFFER WIDTH	10'+	10'+	NO	N/A
TREES	35	42 (STREET TREES)	NO	N/A
SHRUBS/WALL/BERM	YES	189 SHRUBS	NO	N/A
-ADJACENT TO RES. ZONES				
BUFFER WIDTH	N/A	N/A	NO	N/A
SHRUBS/BERM/FENCE/WALL	N/A	N/A	NO	N/A
88-425-06 INTERIOR VEHICULAR USE AREA				
INTERIOR AREA	6,615 SF	11,251 SF	NO	N/A
TREES	39	39	NO	N/A
SHRUBS	189	189	NO	N/A
88-425-07 PARKING GARAGE SCREENING	N/A	N/A	NO	N/A
88-425-08 MECHANICAL/UTILITY EQUIPMENT SCREENING	YES	YES	NO	N/A
88-425-09 OUTDOOR USE SCREENING	YES	YES	NO	N/A

- **Turfgrass**
 - All turf areas shall be sodded and include minimum 4" topsoil. Sod with a commercially available bluegrass/fescue blended sod.
- **Building Foundation Plantings**
 - If space allows, provide a 5' minimum planting bed around all sides of each building. All plantings shall achieve 75% coverage after 3 years.



- **Planting Palette**
 - Minimum plant sizes:
 - Lot Trees (4" caliper)
 - Shrubs (3 gal)
 - Ornamental Grasses (3 gal)
 - Perennials (1 gal)
 - Groundcovers (1 gal); 18" o.c. max spacing
 - Planting material spacing should not exceed the mature wide of each plant. (example: plant that has a mature width of 3', should be spaced 3' o.c. max)
- **Additional Landscape Materials**
 - Mulch: All planting beds shall receive hardwood mulch or decorative rock.
 - Soils: All turfgrass sod areas shall receive commercially available topsoil. All planting areas shall receive a commercially available planting soil mix.
 - Edging: All planting beds shall be edged with metal edge, color: black.

- **Typical Planting Details**

- Tree:

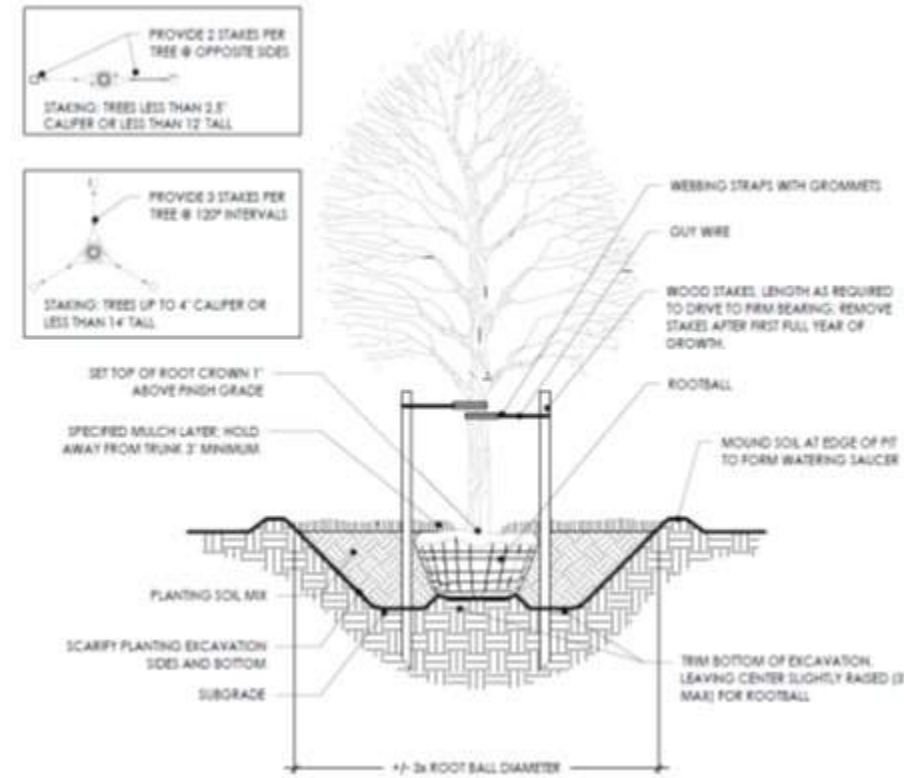

- Shrub:

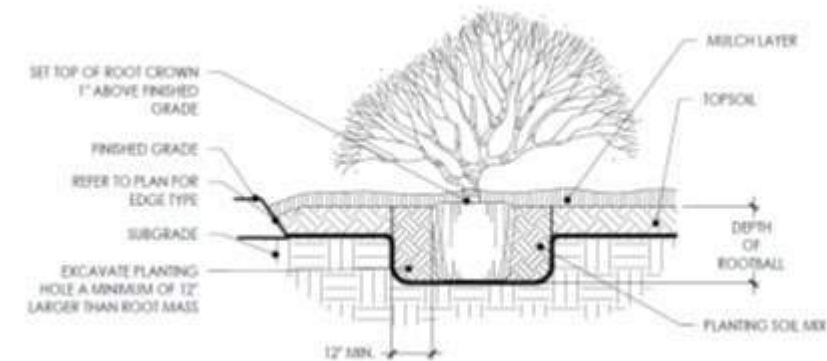

- Groundcover:

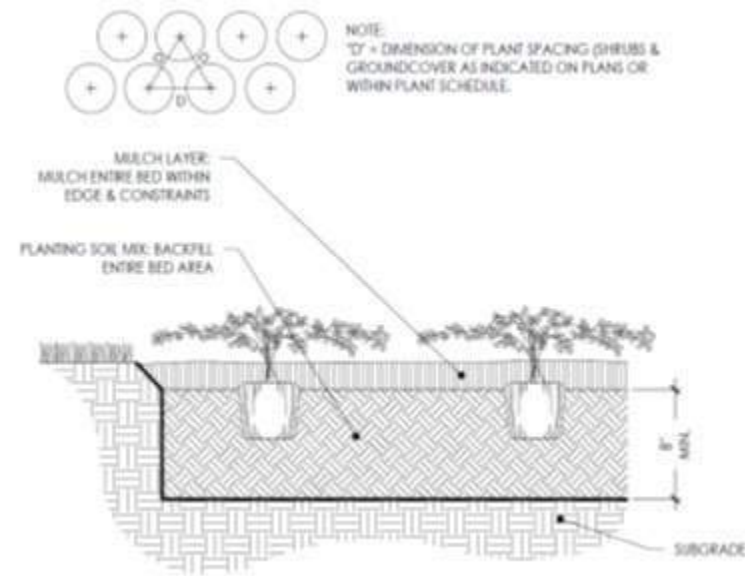

- Metal Edging:

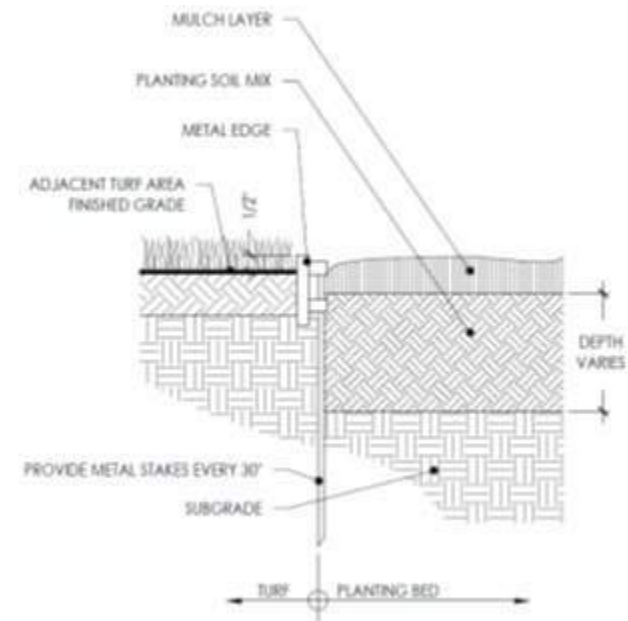

Site Furnishings

Use of site furnishing such as benches, trash enclosures, planting pots and bike racks are highly recommended for inclusion on each lot. Below are general guidelines and basis-of-design.

- **Products**
 - Bench: Manuf: Victor Stanley, <https://victorstanley.com>, Steelsites RB Collection, Model RB-28; Color: Black.
 - Litter Receptacle: Manuf: Victor Stanley, <https://victorstanley.com>, Steelsites RB Collection, Model RB-36; Color: Black.
 - Bike Rack: Manuf: Victor Stanley, <https://victorstanley.com>, Perenne Collection, Model Freesia; Color: Black.



Irrigation Standards

All Irrigation materials and construction shall meet the standards set forth by (ASIC) American Society of Irrigation, and (ASABE/ICC 802-2014 Landscape Irrigation Sprinkler and Emitter Standard) American Society of Agriculture and Biological Engineers.

- **Irrigation System Basis of Design**
 - Each lot shall have an individual automatic irrigation system.
 - Irrigation systems shall utilize domestic water. Water harvesting for irrigation is encouraged but not required. City approved backflow preventer is required.

Provide pop-up spray or rotor irrigation for all turf areas. Planting beds shall include pop-up spray or drip irrigation. Provide head-to-head coverage for all spray or rotor irrigation.

Maintenance General Parameters

- All lots must have ongoing contracted maintenance to ensure landscape quality throughout.
 - Irrigation Maintenance: minimum monthly maintenance to address regular “wear-and-tear” such as nozzles adjustments, clogged heads. Major maintenance items such as broken water lines or heads must be repaired within 48hrs.
 - Tree Maintenance/Care: minimum monthly maintenance. Maintain clear understories of trees (6'-7'). Dead trees must be replaced within a week of being determined dead.
 - Planting Beds: minimum monthly maintenance. Include weeding & pruning. Yearly maintenance to cut back perennials including ornamental grasses. Shrubs must be replaced within a week of being determined dead.
 - Mulch Maintenance: organic wood mulch shall be replaced yearly. Previous years mulch shall be removed disposed of off-site.
 - Fertilizer and weed/disease/insect control: minimum seasonal applications as recommended for general commercial sites.
 - Annual Beds: any use of annual beds shall maintain season rotation of plants.
- All turf areas shall maintain a maximum height of 8”.
- “Mulch volcanoes” around trees are not allowed.
- All irrigation systems must be adjusted to prevent overspray onto adjacent roads and walking surfaces.
- Use of irrigation shall be restricted to off-peak hours between 10pm and 7am operation.
- Irrigation systems shall be winterized each year.

Signage Standards

General Information

All signage shall meet the requirements established by the City of Kansas City, Missouri sign ordinance, and as established by this Landlord sign criteria.

Sign Submittal Requirements

- **Façade sign or Marquee sign**
Provide a storefront elevation of each sign proposed as well as detailed shop drawing elevation and section through sign indicating sign makeup, dimensions, lighting, concealed transformer location, materials, and colors.
- **Storefront safety glazing decals**
Provide a storefront elevation of each sign proposed as well as detailed shop drawing elevation indicating dimensions, materials, and colors.
- **Additional signage / graphics within four feet of storefront**
Provide a storefront elevation, plan, and or section indicating any additional proposed signage as well as detailed shop drawings indicating sign makeup, dimensions, lighting, materials, and colors. All additional signage shall be reviewed on an individual basis.

General Sign Parameters

All signs must be made up of individual illuminated letters; conventional box signs or signs with exposed raceways or transformers will not be approved. Box or cloud signs with raised letters and reverse halo lighting will be considered on an individual basis.

- Tenants must place signs on the exterior of their own Tenant Space unless given specific written permission by the Landlord.
- Lettering on all store signs shall be limited to business or trade name of the premises as it appears on the lease. No sign manufacturer’s name, union labels, website or internet addresses or other lettering shall be visible. Individual Logo signs, included within allowable sign area, will be reviewed on an individual basis.
- Manufacturers’ labels, underwriters’ labels, clips, brackets, or any other form of extraneous advertising attachment or lighting devices shall be fully concealed from public view. Labels installed on sign returns are not permitted.

- No exposed lamps or neon tubing will be permitted.
- No exposed raceways, crossovers or conduits will be permitted.
- All signage returns shall either match face color of sign, black, dark bronze, or blend with adjacent building color.
- All cabinets, conductors, transformers, and other equipment shall be concealed from public areas; visible fasteners will not be permitted.
- All metal letters shall be fabricated using full-welded construction, with all welds ground smooth so as not to be visible.
- Acrylic or trim cap retainers used at the perimeter of sign letter faces shall match in color and finish the face or the sides of the sign.
- Threaded rods or anchor bolts shall be used to mount sign letters, which are spaced out from the building face. Angle clips attached to letter sides will not be permitted. All mounting attachments shall be sleeved, sealed, and painted to match background.
- Except as provided herein, no advertising placards, banners, pennants, names, insignia, trademarks, or other descriptive materials shall be affixed or maintained upon the glass panes and supports of the storefront windows and doors, attached to the interior face of glass, or within 4' of the storefront without prior written approval of the Landlord.
- Any Plexiglas sign faces shall not be clear.
- Sign illumination shall be internal and self-contained generally. In limited applications, and only by specific Landlord approval, externally illuminated signage may be allowed as delineated in this criterion.
- All electric signs and installation methods must meet UL standards and contain a UL label.

- At no time will hand-lettered, non-professional signs, or newspaper advertisements be displayed on the interior or exterior of the storefront.
- All illuminated signs must be turned on during hours as required by the Landlord. The use of time clocks for sign and show window lighting is required.
- All signs must be proportioned to be legible within the 10% of the allowed space per façade. Signs that are too small will not be permitted.
- All signage is subject to the approval of the Landlord and the local authorities and shall fit comfortably within the available signage area.
- If signage is to be serviced from within the building, Tenants shall provide a concealed access panel from within the Tenant's leasable area to service and install exterior building signage.
- One freestanding parking lot directions sign shall be permitted at each parking lot entrance off the public street and shall be centrally located in a landscaped island or median.
 - (a) Sign shall not obstruct traffic viewing angles

Signs Not Permitted

The following types of signs shall not be permitted:

- Any exterior sign or sign panel that extends above any roofline.
- Signs such as die cut vinyl, gold or silver leaf, or paint.
- Boxed pillow or cabinet type signs where entry back panel is illuminated.
- Formed plastic or injection molded plastic signs.
- Banners or pennants. (Only temporary and as approved by Landlord).
- Signature signage (window sign or sign plate

indicating name of shop or good sold) in addition to primary signage.

- Cloth, paper, cardboard and similar stickers or decals around or on surfaces on the storefront without prior written approval.
- Exposed neon signs.
- Animated, video, projected, moving, rotating, or flashing signs.
- Noise making signs.
- Signs that are painted on facades.
- Additional signage of any kind within 4' of storefront windows.
- Awning signage will be allowed in limited applications and only as reviewed and approved by the Landlord.

Tenant Sign Types and Parameters

The following sign types are allowed within these guidelines:

- Tenant sign area shall be on the building faces above the entrances and as part of the building design.
- Maximum one sign per major facade.
- Signs shall not extend more than 8" beyond the face of the surface to which the sign is mounted.
- The maximum size of signage (individual or combined with all other signage on a single facade) shall not exceed 10% of the total area of the façade upon which it is placed.
- Other tenants with exterior entrances shall have sign size based on exterior frontage width as follows:
 - Up to 30' Storefront

- Capital Letters 36"
- Lower Case Letters 30"
- 30'-1" and Greater Storefront
 - Capital Letters 42"
 - Lower Case Letters 36"
- Logo elements that are integrally designed with the signage such as ascenders or descenders and other design elements, may project above or below the maximum letter height for a limited area, not to exceed 25% of the sign width, any maximum height increase of 50% (example 24" letter, 36" logo element). All logos are subject to review and approval. In no case may the total boxed out area for the signs maximum width and height exceed 10% of the building storefront façade.
- All signs must be illuminated and shall derive light from a concealed source. No exposed lamps, globes, tubes, etc. will be permitted.
- Signage shall be channel letters, illuminated individual letters mounted to the building face.
- A single colored or white opaque face is required.
- Reversed halo lighting is encouraged.
- Double stacked lettering shall be allowed on an individual basis only and are subject to Landlord approval. Double-stacked letters shall still be subject to sign limitations.
- No logos will be allowed on Tenant storefronts without prior written approval from the Landlord.

Additional Signage

Blade Signs:

- One blade sign shall be allowed per establishment provided the following criteria have been met.
 - Blade signs shall not exceed 4 SF per side. Signs are to be mounted on pedestrian light poles.
 - Maximum projection of any blade sign shall be 2'6" from the façade face. No portion of the sign may exceed that maximum dimension.
 - Blade signs may be one fixed piece or a combination of arm and sign face.

- The maximum height to the top edge of the blade sign shall be no more than 12 feet from the finished grade or sidewalk below.
- The lowest portions of the blade sign must not be any lower than 8 feet from the finished grade or sidewalk below.

Menu Boards and Signage:

- Each Drive through restaurant shall be permitted two free standing or wall mounted preorder menu and one menu board per drive through window.

- Menu board shall adhere to the following requirements:

- Menu Boards shall not exceed 32 SF, except on Lot 1, which shall not exceed 47 SF.
- Menu Boards shall not exceed 8 feet in height above the finished grade
- Menu Boards shall be located adjacent to and oriented toward the drive through lane and may not contain letters exceeding 6".
- An additional menu board may be allowed if queuing lane length, location and configuration justifies the additional sign.

- Direction driveway signs shall be permitted that do not exceed 4 SF and 42" in height and may not contain letters exceeding 6". Directional signage shall be located within landscaped islands.

Building Address and signs for After Hours of Operation

- Building Addresses shall comply with the edition of the International Codes (I-CODES) as currently adopted by the reference in the City of Kansas City, Missouri Municipal Code
 - Exceptions are color of the number may deviate from black or white for just cause when approved by the code official
- Hours of operation may be displayed as letters applied directly to the store windows and or doors and shall not exceed one square foot.
 - Seasonal variations to the hours of operation may be displayed on temporary window signs for the duration of the change.
 - No flashing or neon signs will be permitted.

Signage on service doors to Tenant spaces throughout the project shall be standard 4" white vinyl Arial letters, identification only (name and address or space number). The Tenant shall not apply any signage or other wording to service doors.