

NOTE:  
Project Plan not required as this development plan contains all of the necessary information.

**MONUMENT SIGN NOTES:**

-Any monument or site sign shall comply with Section 88-445

**MECHANICAL EQUIPMENT AND UTILITY CABINET NOTES:**

-Any Mechanical Equipment and Utility Cabinets shall comply with Section 88-425-08-B and 88-425-08-D

**INDEX OF SHEETS:**

- C.001 - DEVELOPMENT PLAN
- C.002 - EXISTING CONDITIONS
- C.003 - PRELIMINARY PLAT
- C.004 - PRELIMINARY STREAM BUFFER PLAN
- C.005 - REZONING PLAN
- C.100 - OVERALL SITE PLAN
- C.101 - DIMENSION PLAN
- C.102 - OVERALL SIDEWALK PLAN
- C.200 - OVERALL GRADING PLAN
- C.300 - UTILITY PLAN
- L.100 - LANDSCAPE PLAN
- A.1 - EXTERIOR ELEVATIONS
- A.2 - EXTERIOR ELEVATIONS

**City Plan Commission**  
Approved Subject to Conditions  
of Case No. **CD-CPC-2024-00060** on **07-03-2024**  
**CD-CPC-2024-00061**

*Diane Binkckley*  
Diane Binkckley, AICP  
Secretary of the City Plan Commission

# DEVELOPMENT PLAN

## BARRYVIEW

Kansas City, Platte County, Missouri

NOTE:  
Wayfinding signage will be installed.

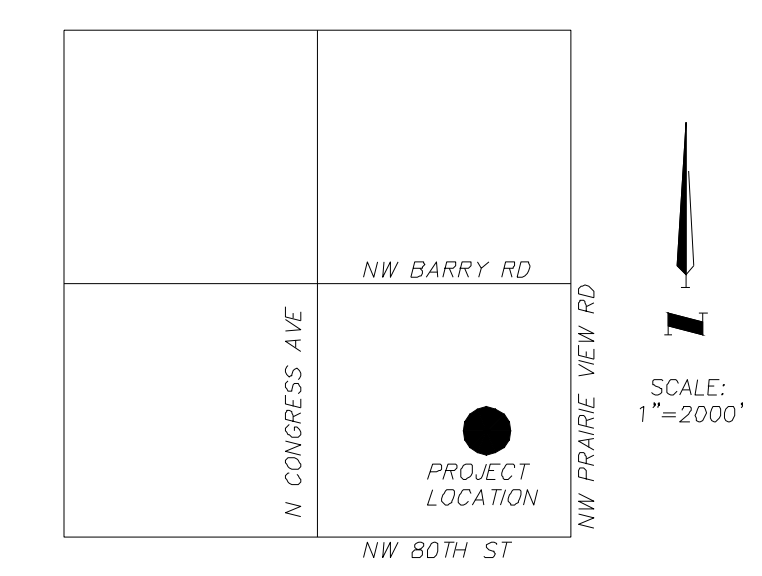
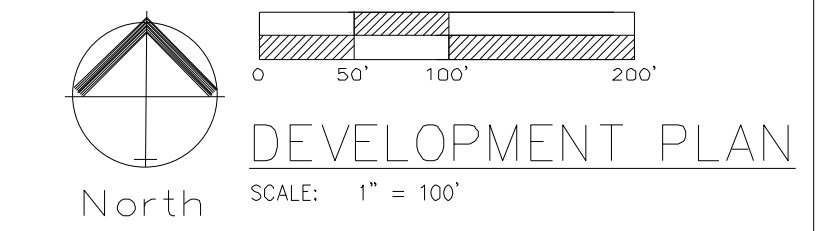

VICINITY MAP  
SEC. 12-51-34

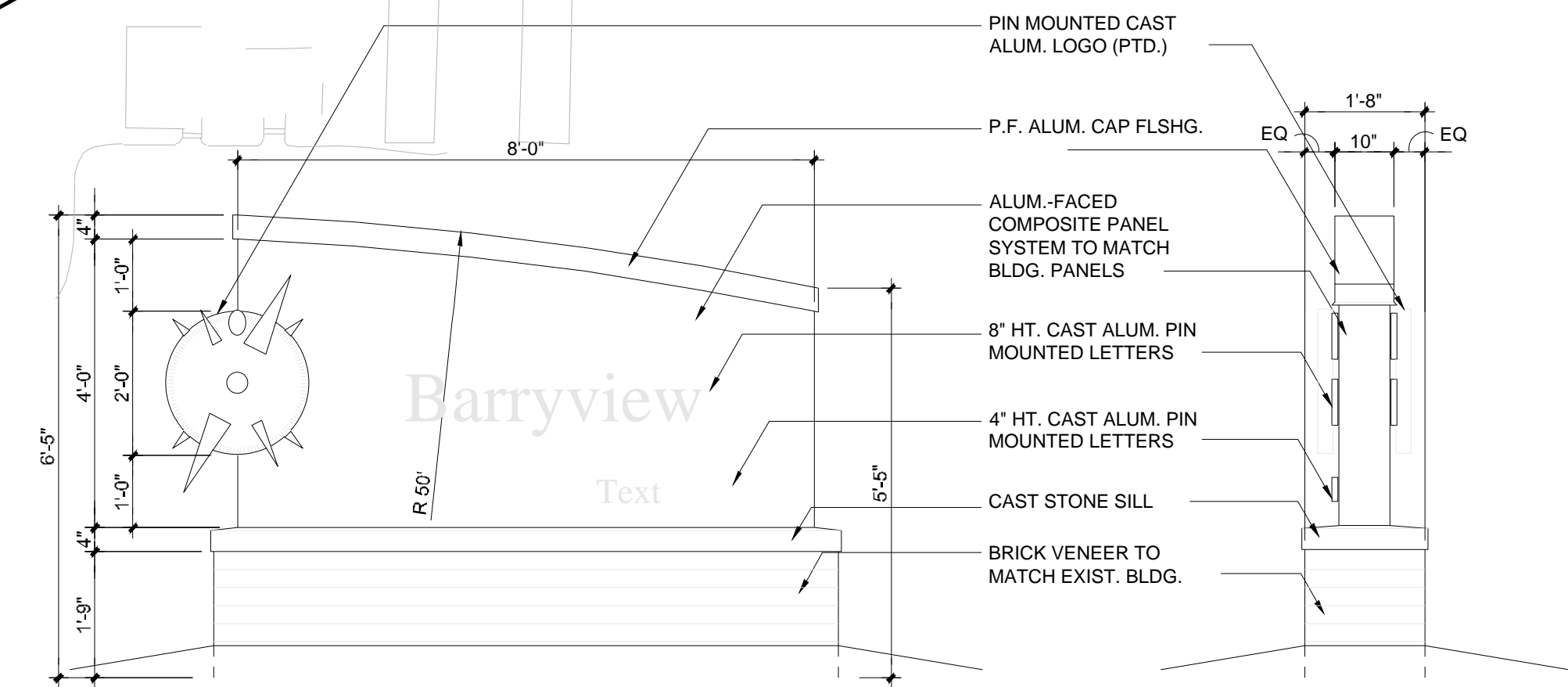

Development Summary Table			
a	<b>Zoning</b>		
	Existing		R2.5
	Proposed		R1.5
b	<b>Total Land Area</b>		
	Existing	15.26	Acres
	Proposed	0	Acres
c	<b>Right-of-Way</b>		
	Existing	0	Acres
	Proposed	0	Acres
d	<b>Net Land Area</b>		
	Existing	15.26	Acres
	Proposed	15.26	Acres
	Proposed	664816.53	SF
e	<b>Proposed Uses</b>		
	RESIDENTIAL		
f	<b>Structure Height &amp; Number of Floors</b>		
	SIX-PLEX Number of floors	2	stories
	Height Above Grade	30	feet
	FOUR-PLEX Number of floors	2	stories
	Height Above Grade	30	feet
g	<b>Gross Floor Area &amp; Number of Units</b>		
	SIX-PLEX		
	Gross Area per Building	5334	SF
	Units per Building	6	EA
	Number of Buildings	23	EA
	6 Plex Units	138	EA
	FOUR-PLEX		
	Gross Area per Building	3556	SF
	Units per Building	4	EA
	Number of Buildings	3	EA
	4 Plex Units	12	EA
	Total Units	150	
h	<b>Building Coverage &amp; Floor Area Ratio</b>		
	Coverage (Total Footprint Area)	133350	SF
	FAR (Gross Area/Net Land Area)	0.201	FAR
i	<b>Density</b>		
	Nets Density (Units/ Net Land Area)	9.83	Units per Acre
k	<b>Vehicle Parking</b>		
	Ratio Required	1 stall per unit	
	Stalls Required	150	Stalls
	Stalls Provided	349	Stalls
l	<b>Bike Parking</b>		
	Long Term Ratio Required	10% of Veh. Parking-12 Spaces in Unit	
	Spaces Provided	12	Spaces
	Short Term Ratio Required	10% of Veh. Parking-12 Spaces	
	Spaces Provided	12	Spaces
m	<b>Timeline</b>		
	Estimated Start Date:	FALL	2024
	Estimated Completion Date:	FALL	2025
n	<b>Deviation Requests</b>		
		NONE	

- NOTES:
- ALL UNITS TO HAVE PRIVATE TRASH BIN.

**BICYCLE PARKING**  
INSTALL THREE (3) - 6 BAY BIKE RACKS.

**LONG TERM BICYCLE PARKING**  
Long Term Bicycle Parking will be located within each individual unit. Complies with Section 88-420-09-C.a.3

**OWNER:**  
Phoenix Capital Partners LLC  
9744 N CONANT AVE  
KANSAS CITY, MO 64153-0000

**CIVIL ENGINEER:**  
ENGINEERING SOLUTIONS  
CONTACT NAME: MATT SCHLICHT  
EMAIL: mschlicht@es-kc.com  
PHONE: 816-623-9888  
ADDRESS: 50 SE 30TH STREET  
LEE'S SUMMIT, MO 64082

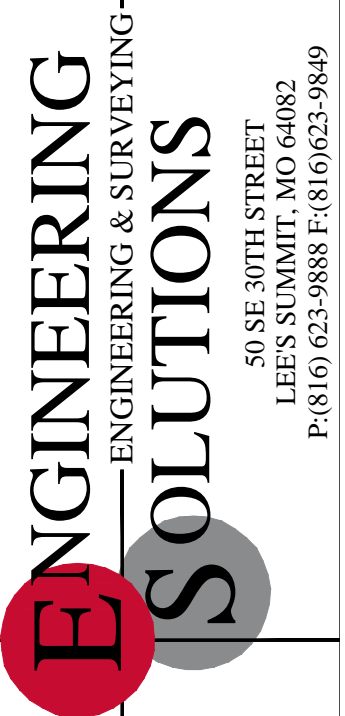

Professional Registration  
Missouri  
Engineering 200502186-D  
Surveying 2005038318-D  
Kansas  
Engineering E-1695  
Surveying LS-218  
Oklahoma  
Engineering 6254  
Nebraska  
Engineering CA2821

8199 NW Milrey Dr  
Kansas City, Platte County, Missouri

Project: BARRYVIEW SQUARE, KCMO  
Issue Date: April 25, 2024

DEVELOPMENT PLAN  
Development Plan for:  
BARRYVIEW  
Kansas City, Platte County, Missouri

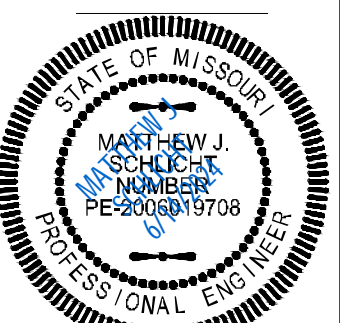

REVISIONS

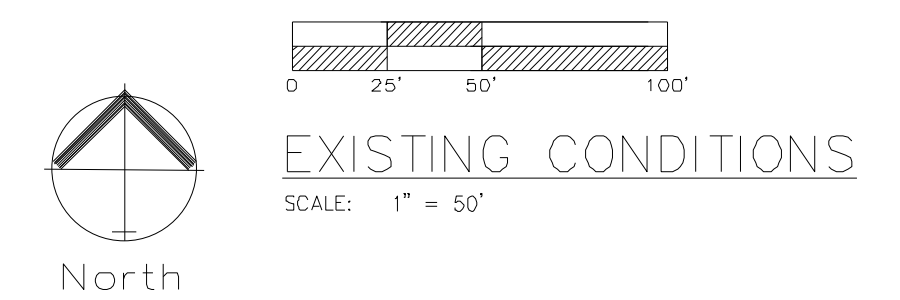
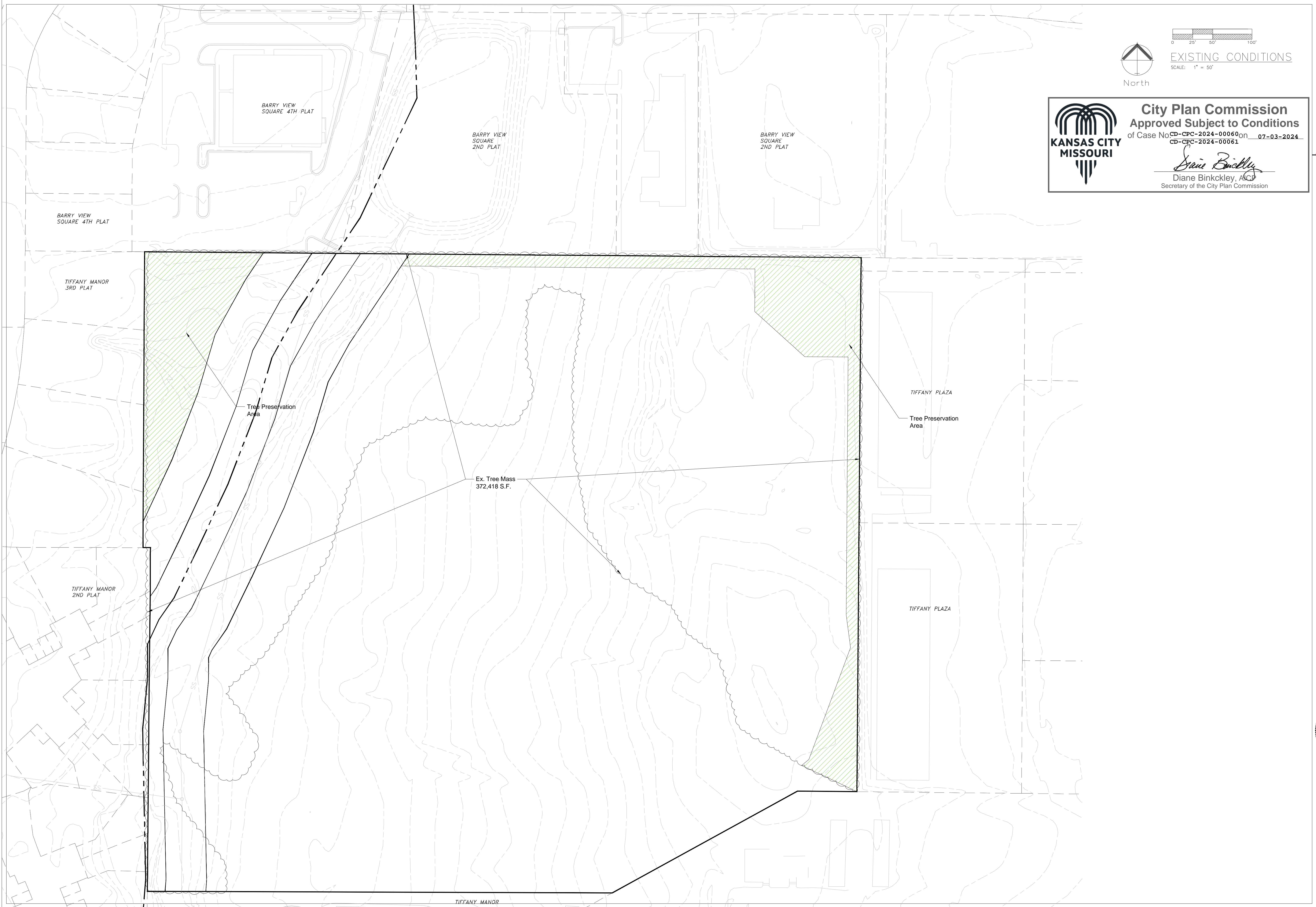

**City Plan Commission**  
 Approved Subject to Conditions  
 of Case No. CD-CPC-2024-00060 on 07-03-2024  
 CD-CPC-2024-00061  
  
 Diane Binkckley, ACP  
 Secretary of the City Plan Commission

**ENGINEERING SOLUTIONS**  
 ENGINEERING & SURVEYING  
 50 SE 30TH STREET  
 LEES SUMMIT, MO 64082  
 P: (816) 623-9888 F: (816) 623-9849

Professional Registration  
 Missouri  
 Engineering 200502186-D  
 Surveying 2005008318-D  
 Kansas  
 Engineering E-1695  
 Surveying LS-210  
 Oklahoma  
 Engineering 6254  
 Nebraska  
 Engineering CA2821

8199 NW Milrey Dr  
 Kansas City, Platte County, Missouri

Project: BARRY VIEW SQUARE 4TH PLAT  
 Issue Date: April 25, 2024

**EXISTING CONDITIONS**  
 Development Plan for:  
**BARRYVIEW**  
 Kansas City, Platte County, Missouri

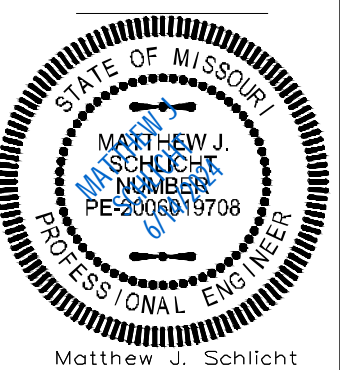

Matthew J. Schlicht  
 MO PE 2006019708  
 KS PE 19071  
 OK PE 25226  
 NE PE E-14335

REVISIONS

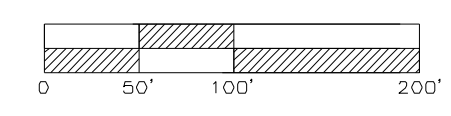
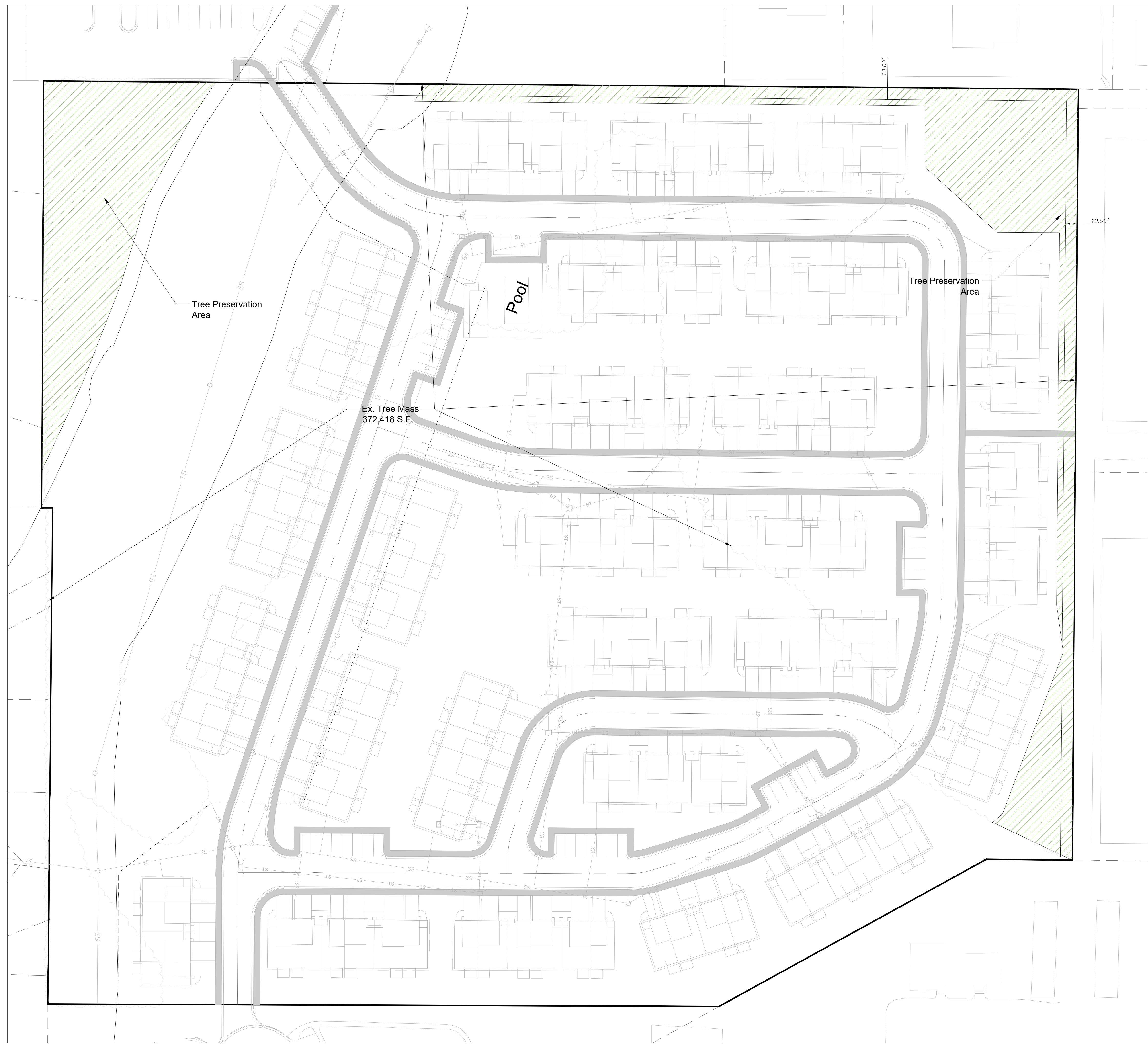
North  
 TREE PRESERVATION PLAN  
 SCALE: 1" = 100'

**NOTE:**  
 INTERNAL TREES WILL BE PRESERVED AS MUCH AS POSSIBLE. TO BE DETERMINED WITH CONSTRUCTION PLANS.

88-424-07 - MITIGATION RATE	
88-424-07-A. The following mitigation rate is applicable to tree canopy cover removed. Required mitigation shall be calculated as follows:	
1. First, calculate the total acreage of contiguous canopy cover to be removed on the entire development site. Subtract total acreage of all areas of contiguous tree canopy cover of one acre or more preserved outside of any stream buffer.	317326 s.f. 7.28 ac.
2. Second, subtract all undisturbed acres of stream buffer	0
3. Third, multiply the acreage calculated in step two by 0.35	2.55
4. Fourth, multiply the acreage calculated in step three by 150 caliper inches	382
5. Fifth, subtract the total caliper inches of trees provided for required landscaping per 88-425	244
6. The final result is the number of caliper inches required for mitigation. Caliper inches of trees planted shall satisfy this requirement, meaning, a two-inch caliper tree shall satisfy two inches of required mitigation. Payment in-lieu calculation can be found in 88-424-12.	81
88-424-07-B. Open Space Developments and Conservation Developments Mitigation rates shall be reduced by 50% for trees removed if a development plan is approved pursuant to 88-410 Open Space Developments and Conservation Developments.	N/A

\* 8 - 3" TREES ADDED TO MEET REQUIRED LANDSCAPING PER 88-424-07  
 SEE L.100 FOR TREES.  
 DEVELOPER MAY PAY \_\_\_\_\_ IN LIEU OF TREES.

**City Plan Commission**  
**Approved Subject to Conditions**  
 of Case No. CD-CPC-2024-00060 on 07-03-2024  
 CD-CPC-2024-00061

*Diane Binkckley*  
 Diane Binkckley, AICP  
 Secretary of the City Plan Commission

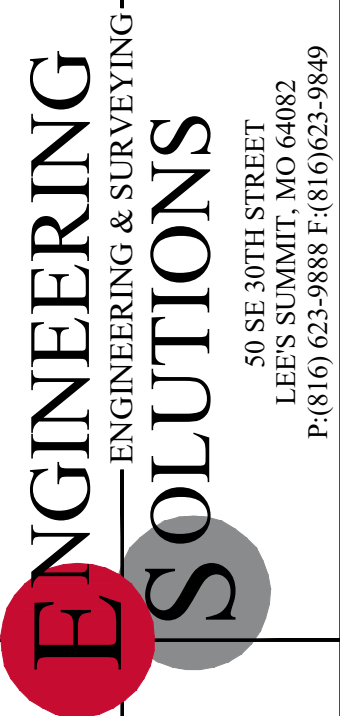

Professional Registration  
 Missouri  
 Engineering 200502186-D  
 Surveying 2005038318-D  
 Kansas  
 Engineering E-1695  
 Surveying LS-218  
 Oklahoma  
 Engineering 6254  
 Nebraska  
 Engineering CA2821

8199 NW Milrey Dr  
 Kansas City, Platte County, Missouri

Project: BARRYVIEW SQUARE, KCMO  
 Issue Date: April 25, 2024

Tree Preservation Plan for:  
 BARRYVIEW  
 Kansas City, Platte County, Missouri

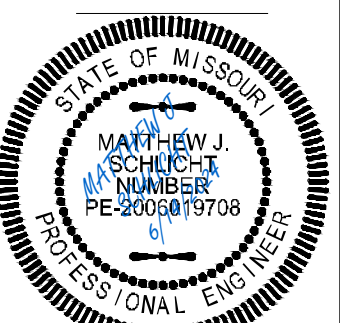

Matthew J. Schlicht  
 MO PE 2005019708  
 KS PE 19071  
 OK PE 25226  
 NE PE E-14335

REVISIONS

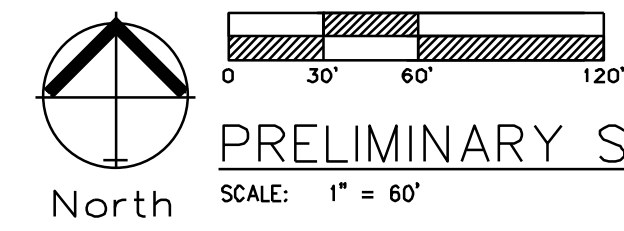
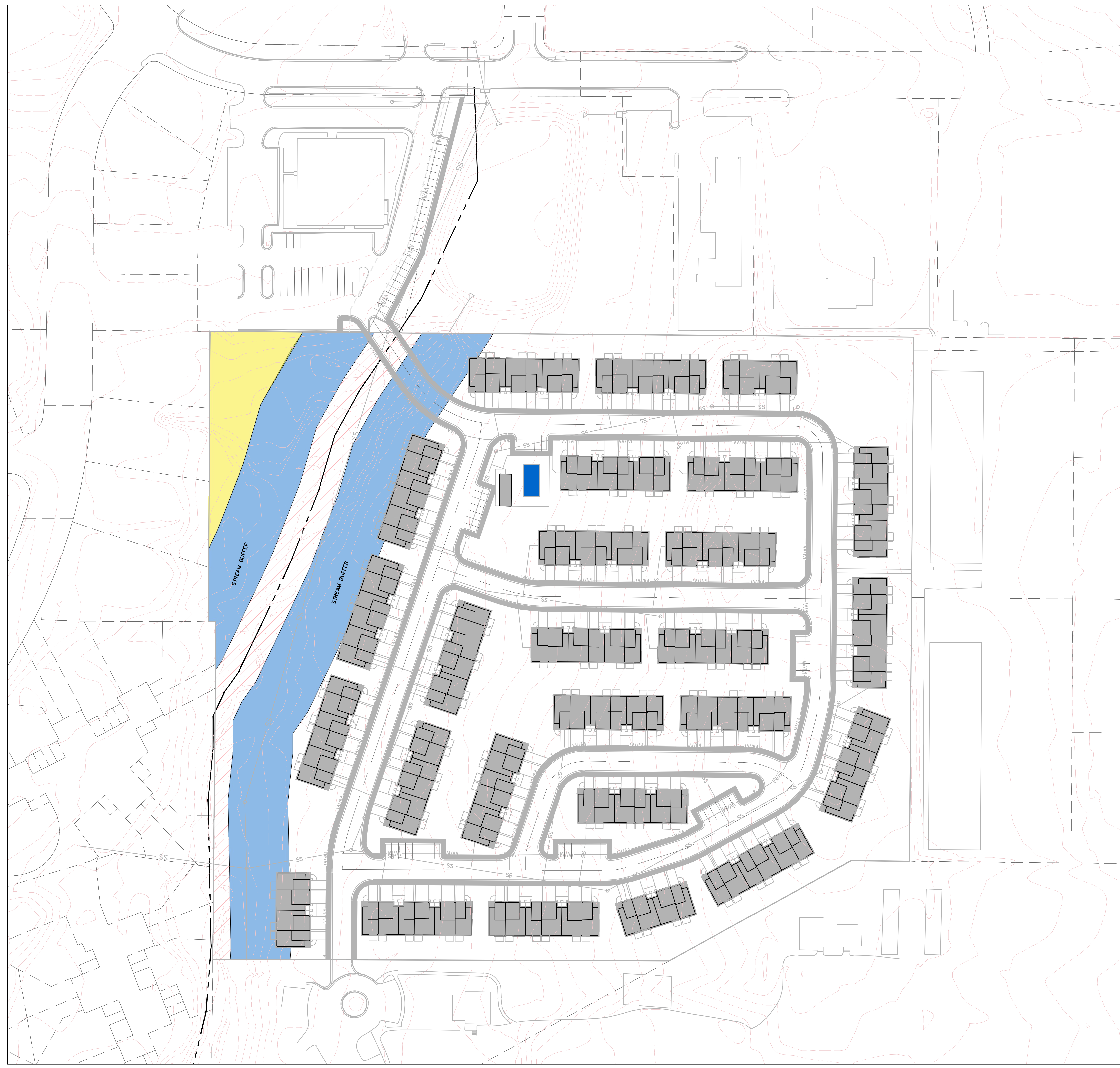
**PRELIMINARY STREAM BUFFER PLAN**

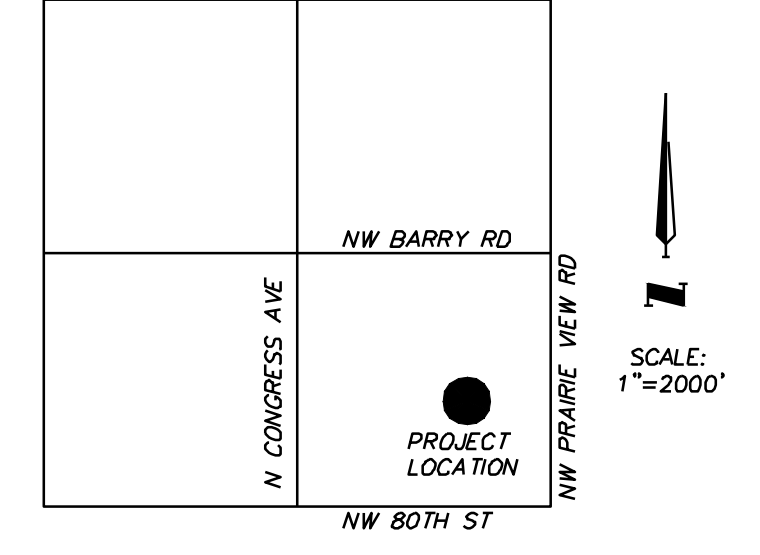

VICINITY MAP  
SEC. 12-51-34



**City Plan Commission**  
Approved Subject to Conditions  
of Case No. CD-CPC-2024-00060 on 07-03-2024  
CD-CPC-2024-00061

*Diane Binkckley*  
Diane Binkckley, AICP  
Secretary of the City Plan Commission



Professional Registration  
Missouri  
Engineering 200502186-D  
Surveying 2005008318-D  
Kansas  
Engineering E-1695  
Surveying LS-218  
Oklahoma  
Engineering S254  
Nebraska  
Engineering CA2821

8199 NW Milrey Dr  
Kansas City, Platte County, Missouri

Project: VIEW SQUARE, KCMO  
Issue Date: April 25, 2024

PRELIMINARY STREAM BUFFER PLAN  
Development Plan for:  
BARRYVIEW  
Kansas City, Platte County, Missouri



Matthew J. Schlicht  
MO PE 2006019708  
KS PE 19071  
OK PE 25226  
NE PE E-14335

REVISIONS

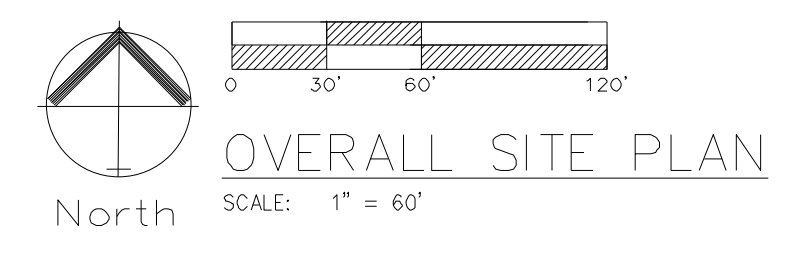
**KANSAS CITY MISSOURI**

**City Plan Commission**  
**Approved Subject to Conditions**  
 of Case No. CD-CPC-2024-00060 on 07-03-2024  
 CD-CPC-2024-00061

*Diane Binkckley*  
 Diane Binkckley, A.C.P.  
 Secretary of the City Plan Commission

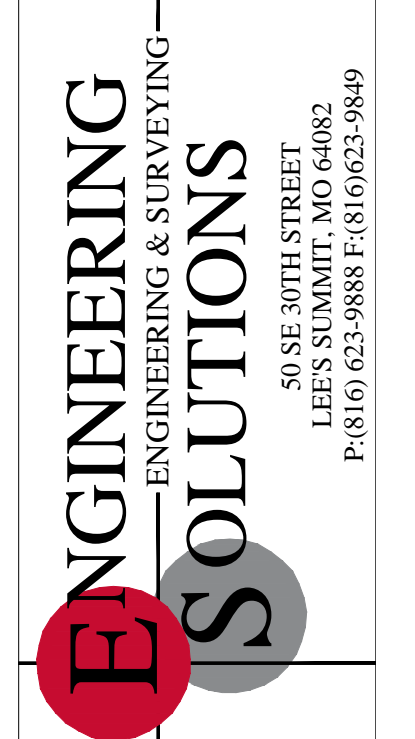

Professional Registration  
 Missouri  
 Engineering 200502186-D  
 Surveying 2005008318-D  
 Kansas  
 Engineering E-1695  
 Surveying LS-218  
 Oklahoma  
 Engineering 6254  
 Nebraska  
 Engineering CA2821

8199 NW Milrey Dr  
 Kansas City, Platte County, Missouri

Project: BARRY VIEW SQUARE KCMO  
 Issue Date: April 25, 2024

OVERALL SITE PLAN  
 Development Plan for:  
**BARRYVIEW**  
 Kansas City, Platte County, Missouri

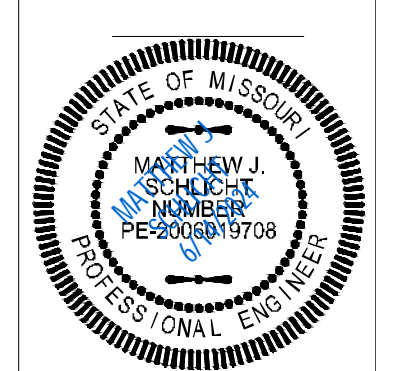

Matthew J. Schlicht  
 MO PE 2006019708  
 KS PE 19071  
 OK PE 25226  
 NE PE E-14335

REVISIONS

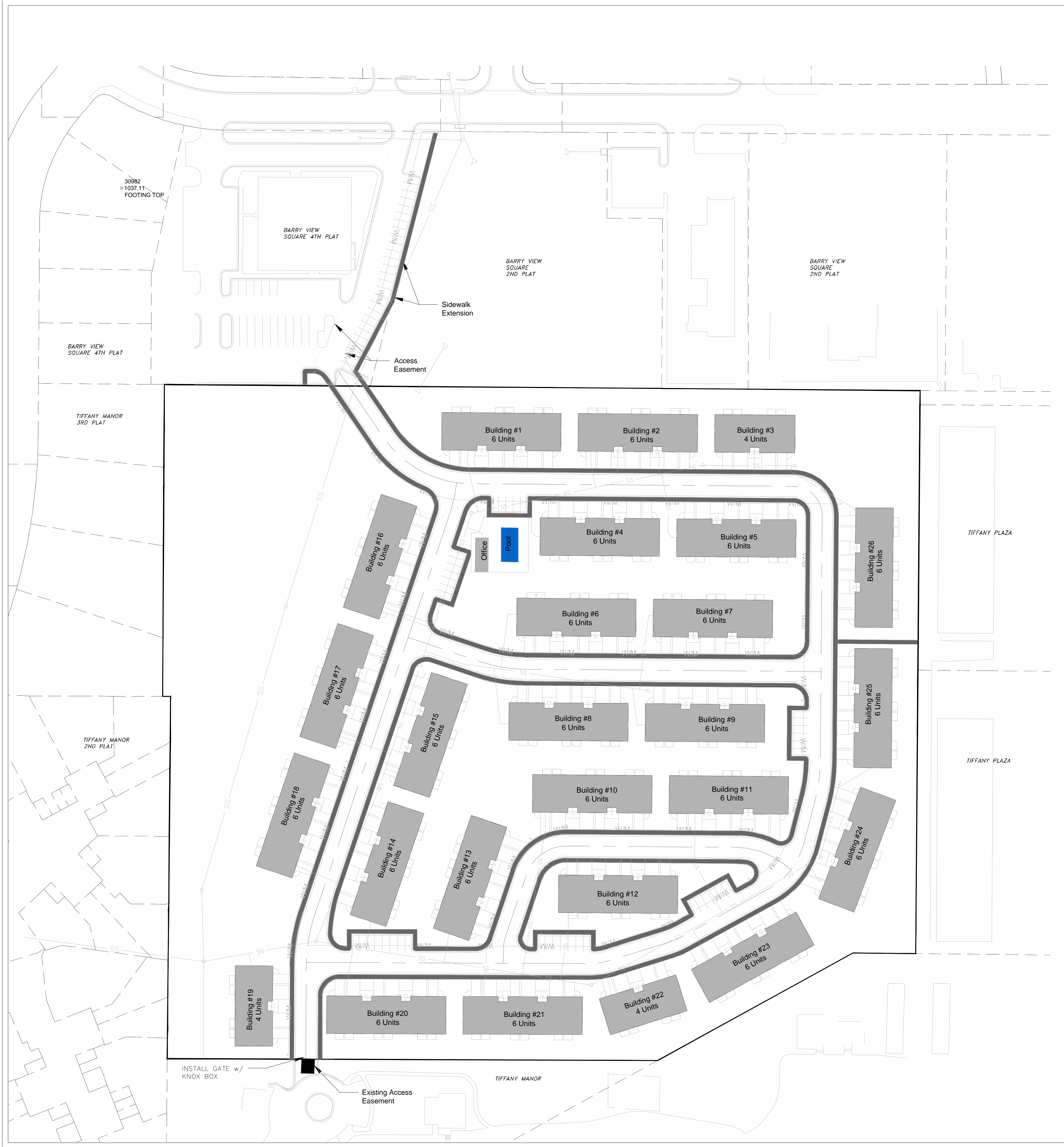



BUILD IN ACCORDANCE WITH 2012  
INTERNATIONAL RESIDENTIAL  
CODE AND LOCAL CODES.

Barryview

SCALE  
1/4" = 1'-0"

DATE  
4-30-19

PLAN NO.

2775

SHEET NO.

A1

KOSBY A. TOWNSEND  
ARCHITECT  
PROFESSIONAL SEAL  
REGISTERED ARCHITECT  
MISSOURI

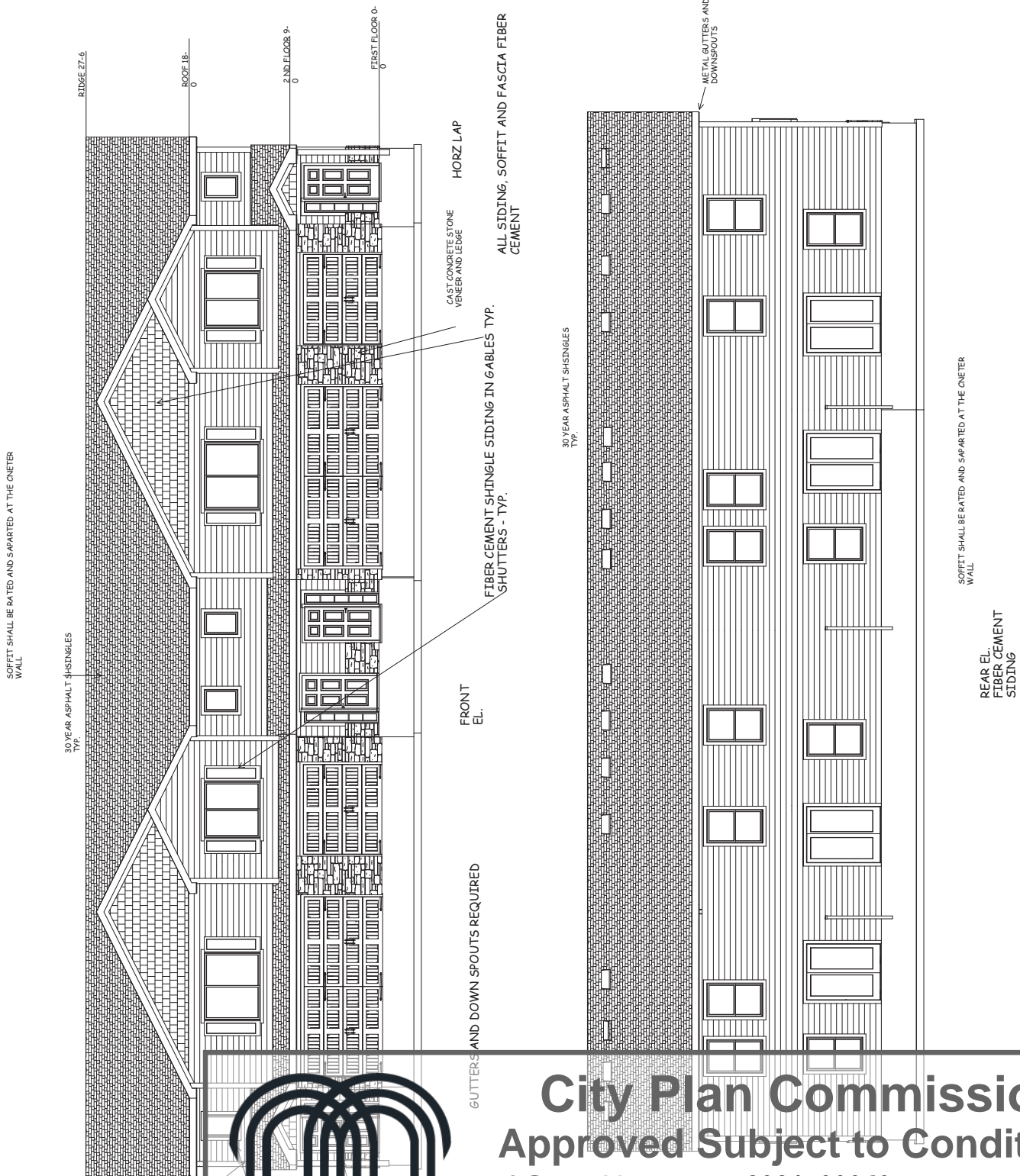

**City Plan Commission**  
**Approved Subject to Conditions**  
 of Case No. CD-CPC-2024-00060 on 07-03-2024  
CD-CPC-2024-00061

*Diane Binkckley*  
**Diane Binkckley, AICP**  
 Secretary of the City Plan Commission





# City Plan Commission

## Approved Subject to Conditions

of Case No. CD-CPC-2024-00060 on 07-03-2024  
CD-CPC-2024-00061

*Diane Binkckley*

Diane Binkckley, AICP  
 Secretary of the City Plan Commission

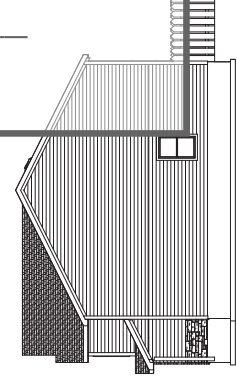
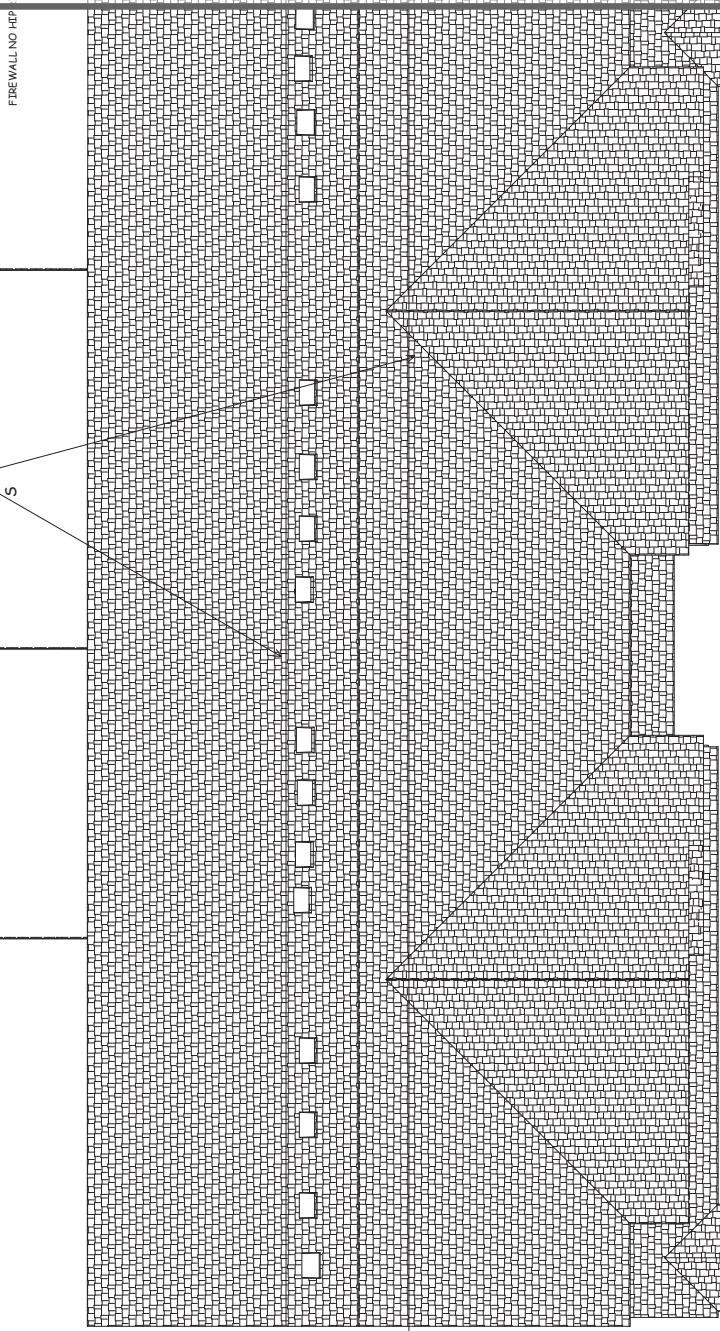

RIGHT EL.  
 1/8" = 1'-0"

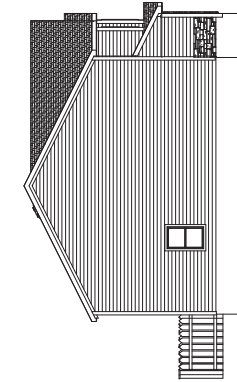

LEFT EL.  
 1/8" = 1'-0"

FRONT GABLE WALLS 12"  
 SOFFITS  
 RAFTERS 2 X 6 DF NO 2 @ 16" OC TYP.  
 U.N.O.  
 HIPS AND RIDGES 2 X 8 DF NO 2 UN/O

GUTTERS AND DOWN SPOUTS REQUIRED

FIBER CEMENT LAP  
 SIDING TYP.

ROOF PLAN  
 FRONT TO BACK 6/12  
 SIDE TO SIDE 6/12  
 12" SOFFITS TYP.

BUILD IN ACCORDANCE WITH 2012  
 INTERNATIONAL RESIDENTIAL  
 CODE AND LOCAL CODES.

TOWNHOMES AT CREEKSIDE MEADOWS  
 PARKVILLE MO

SCALE 1/4" = 1'-0	DATE 4-30-19	PLAN NO. 2775	SHEET NO. A2
----------------------	-----------------	------------------	-----------------

FORBY A. TORIAN P.E.  
 ARCHITECT  
 1000 E. 12TH ST.  
 KANSAS CITY, MO 64108

# Barryview – 4-Plex and 6-Plex

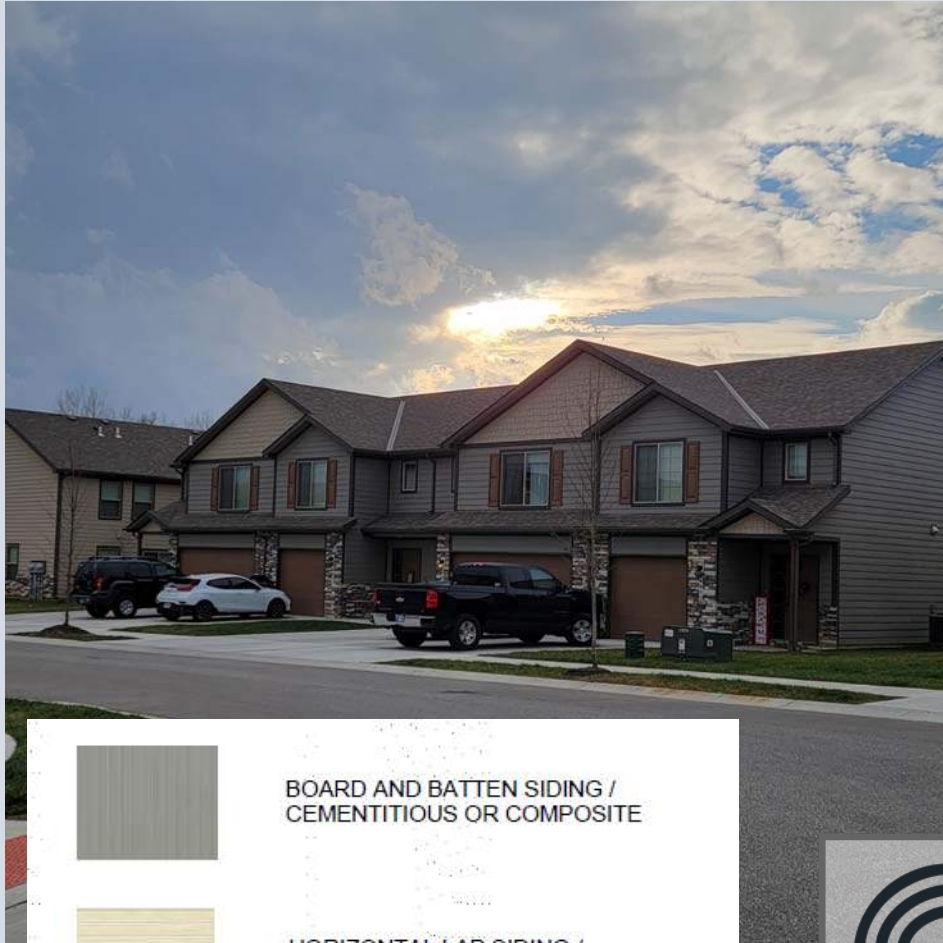

BOARD AND BATTEN SIDING /  
CEMENTITIOUS OR COMPOSITE



HORIZONTAL LAP SIDING /  
CEMENTITIOUS OR COMPOSITE



MANUFACTURED STONE VENEER



**City Plan Commission**  
**Approved Subject to Conditions**  
of Case No. CD-CPC-2024-00060 on 07-03-2024  
CD-CPC-2024-00061

A handwritten signature in black ink that reads "Diane Binkckley".

Diane Binkckley, AICP  
Secretary of the City Plan Commission