



**City of Kansas City, Missouri
Water Services Department
Kelly Postlewait, Director**

Project Manual

PROJECT/CONTRACT NO. 60800073/9848

**Water Department Emergency Transmission
Water Main Repair**

BIDDER/ADDRESS

Company	_____
Contact	_____
Address	_____

Phone	_____
Fax	_____
Email	_____

Project Manager: Jason Wright
Telephone: 816-513-4772
Email: Jason.Wright@kcmo.org



ADDENDUM NUMBER 1

Project Number 60800073

Project Title Water Department Emergency Transmission Water Main Repair

ISSUE DATE: 3/8/2024

Bidding Requirements

1. Add the following sections:

- a. Document, Bidding Requirement, 00485.01, MWBE Monthly Utilization Report
- b. Document, Bidding Requirement, 00485.01.1, MWBE Monthly Utilization Report Instructions
- c. Document, Bidding Requirement, 00485.02, Project Specific Workforce Monthly Report
- d. Document, Bidding Requirement, 00485.02.1, Workforce Monthly Report Instructions
- e. Document, Bidding Requirement, 00485.03, Company-Wide Workforce Monthly Report
- f. Document, Bidding Requirement, CREO 14 Affirmative Action Program Affidavit

2. Delete the following section:

- a. Document, Specification 02641, Valves

3. Delete and replace the following section:

- a. Delete Document 00010, Table of Contents, and replace with the following Document, 00010, Table of Contents:
- b. Delete Document 00130, Invitation to Bid, and replace with the following Document 00130, Invitation to Bid:

NOTE: Bidders must acknowledge receipt of this Addendum by listing the number and date, where provided, on the Bid Form - Document 00410.

M/WBE Monthly Compliance Audit Online Reporting Instructions

PRIME INSTRUCTIONS:

The Prime's responsibility is to report payments made to subcontractors for the prior month.

1. Log into B2GNow Diversity Management System (B2GNow)
2. On the Dashboard, click Contract Audits.
3. Select the specific audit that needs to be completed. Any and all money that changed hands during the month of the audit must be reported to the specific audit month.
4. To complete audit select Report 1 Subcontractor Payment. Under the actions column, select Submit Response for the specific subcontractor that needs reporting or select the Submit ALL Incomplete Records button to go to all the subcontractors to report amounts. Under the audit information answer the following questions:

The screenshot shows a form titled "Audit Information" with a blue header. Below the header, there is a text input field for "Amount PAID for June 2020" with a dollar sign icon and a red asterisk. A red note below it says "Do NOT enter invoice amount." There is also a "Payment Date" field with a red note: "Enter payment date if you made a payment for June 2020" and "If multiple payments were made, enter the date of the first payment." The "Payment Detail" section has a text area with instructions: "Enter details of PAID check numbers (or ACH references) and amounts for June 2020. This information is optional but will speed up the confirmation process. Payment details are displayed to Dan's Contracting Test."

Once information has been entered, select review and save. Complete same steps for all subcontractors. If there were subcontractors that did not receive a payment for the specific audit month, click the Mark Remaining Subcontractors as Zero button to mark remaining subcontractors as 0.

SUBCONTRACTOR INSTRUCTIONS:

The responsibility of the Subcontractor is to confirm payment received for specific audit month.

1. Log in to B2GNow Diversity Management System (B2GNow)
2. On the Dashboard, select Contract Audits.
3. Select the specific audit that needs to be completed.
4. To complete audit, select Confirm Payment Received. There will be two options: correct or incorrect. Select correct if payment was in fact received OR if payment was not received or amount was different select incorrect. Answer all questions and select save to complete.

The screenshot shows a form titled "Compliance Audit Information" with a grey header. It contains several sections: "Amount Reported by the prime contractor for November 2021 as PAID to You" with a value of "\$500.00"; "Confirm Reported Amount?" with radio buttons for "Correct - the amount reported by the prime contractor as PAID to us is correct (\$500.00)." and "Incorrect - the amount reported by the prime contractor as PAID to us is not correct."; "Final Payment?" with radio buttons for "No - our work on this contract continues." (selected), "Yes - this is our last payment for this contract.", and "N/A - we have not begun work on this project or we have not been paid yet for our work."; and "Is Prime Withholding Retainage?" with radio buttons for "No" and "Yes".

NOTE: Complete one M/WBE report per project.

An email notice will be sent from our organization monthly to notify Prime & Subcontractor users of incomplete audits.



Project-Specific Workforce Monthly Report

Human Relations Department - City of Kansas City Missouri

Report Date:	Reporting Period:	Project Description:	
Project Name:	Contractor:	Contract Awarded Date:	
City Project Number:	Contractor Address:	City Contract Number:	
Project Address:		City Vendor ID:	
	Contact Person/Phone:	Contractor Report <input type="checkbox"/>	Subcontractor Report <input type="checkbox"/>

E-mail Address: _____ Final Cumulative Report: Yes No

Report the total monthly hours of work performed by all workers on the City Construction Contract. Enter the total hours on all lines and in all columns. Reported _____

workforce hours should be based on payroll records.

JOB CATEGORIES	OVERALL TOTAL (Sum of all Columns, A thru F Male & Female)	A Total Hours White Employees		B Total Hours Black Employees		C Total Hours Hispanic Employees		D Total Hours Asian/Pacific Islander		E Total Hours Native American Employee		F Total Hours Other/Unknown Race Employee		G KCMO Resident Hours
		M	F	M	F	M	F	M	F	M	F	M	F	Total #
		Foreman/Supervisor												
Asbestos Worker Journeyman														
Asbestos Worker Apprentice														
Boilermaker Journeyman														
Boilermaker Apprentice														
Bricklayer Journeyman														
Bricklayer Apprentice														
Carpenter Journeyman														
Carpenter Apprentice														
Cement Mason Journeyman														
Cement Mason Apprentice														
Electrician Journeyman														
Electrician Apprentice														
Elevator Constructor Journeyman														
Elevator Constructor Apprentice														
Glazier Journeyman														
Glazier Apprentice														
Iron Worker Journeyman														
Iron Worker Apprentice														
Laborer Journeyman														
Laborer Apprentice														
Operating Engineer Journeyman														
Operating Engineer Apprentice														
Painter Journeyman														
Painter Apprentice														
Pipe Fitter/Plumber Journeyman														
Pipe Fitter/Plumber Apprentice														
Plasterer Journeyman														
Plasterer Apprentice														
Roofer Journeyman														
Roofer Apprentice														
Sheet Metal Journeyman														
Sheet Metal Apprentice														
Sprinkler Fitter														
Sprinkler Fitter Apprentice														
Truck Driver Journeyman														
Truck Driver Apprentice														
Welder Journeyman														
Welder Apprentice														
Other														
Monthly Total Hours														-
Total % of Monthly Hrs.														

Contractor shall submit report by the 15th of each month.

Phillip Yelder, Director Human Relations Department 414 E. 12th Street, 4th Floor Kansas City, MO 64106 Phone: 816-513-1836 Email: HRDcontractcompliance@kcmo.org	Report Submitted By: _____ Date: _____
---	---

Workforce Monthly Report Forms only apply to Construction Contracts greater than \$300,000.00 with greater than 800 projected labor hours.

Workforce Monthly Report Instructions

(Instructions for online reporting)

Completing a Workforce Audit:

To report your workforce hours:

1. Log into B2GNow Diversity Management System (B2GNow)
2. Click on the red underlined number of 'Incomplete audits' under Workforce Audits
3. Click View for the incomplete audit that needs to be completed.
4. Click Fill in Audit
5. Complete the form including the Payroll Number. Select Add to Audit to report hours worked for specific Craft/Trade.

* required entry

Summary Information	
CONTRACTOR	KCMO Test Vendor Sample
PAYROLL START DATE	11/1/2021
PAYROLL END DATE	11/30/2021
PAYROLL NUMBER	<input type="text"/>
SPECIAL STATUS	<input type="checkbox"/> No Work (all fields will be filled with zeros) <input type="checkbox"/> Suspended <input type="checkbox"/> Final

Enter values below as hours worked. There is no need to fill in zeros; all blank fields will be saved as zero.

Craft/Trade	Caucasian		Black/African American		Hispanic/Latino		Asian		Native American		Other/Unknown Ethnicity		Local Resident	Comments
	Male	Female	Male	Female	Male	Female	Male	Female	Male	Female	Male	Female		
Foreman/Supervisor														Not included in audit Add to Audit
Asbestos Worker (Journeyman)														Not included in audit Add to Audit

6. Scroll down and select review once hours have been reported.
7. Save and Certify to submit OR Save but Certify Later (to save a draft of your audit response). Audit must be certified for the workforce audit to be submitted for review. If there is an audit where no work was performed, and have 0 hours to report, select the Mark as No Work Audit button on step 4 to report 0 hours for all your employees. Select Certify & Release to Organization to complete. Mark Final for Special Status if the audit being completed is the last month of work, this will notify the system to stop generating monthly audits.

NOTE: If subcontractor has completed Workforce Audit, Prime MUST either accept audit and release to the organization or reject audit back to Subcontractor for correction.

An email notice will be sent from our organization monthly to notify Prime & Subcontractor users of incomplete audits.



Company-Wide Workforce Monthly Report

Human Relations Department - City of Kansas City, Missouri

Report Date:	Reporting Period:	Contract Awarded Date:	
Contractor:		City Vendor ID:	
Contact Person/Phone:	Contractor Address:	Contractor Report <input type="checkbox"/>	Subcontractor Report <input type="checkbox"/>
E-mail Address:	Have you hired any new construction workers this month?	<input type="checkbox"/> Yes #:	Final Cumulative Report: <input type="checkbox"/> Yes <input type="checkbox"/> No
		<input type="checkbox"/> No	

Report total of all hours of work performed company-wide on all projects in the KCMO Metropolitan Statistical Area (MSA). Enter the total hours on all lines and in all columns. Workforce hours should be based on payroll records.

JOB CATEGORIES	OVERALL TOTAL (Sum of all Columns, A thru F Male & Female)	A Total Hours White Employees		B Total Hours Black Employees		C Total Hours Hispanic Employees		D Total Hours Asian/Pacific Islander		E Total Hours Native American Employee		F Total Hours Other/Unknown Race Employee		G KCMO Resident Hours	
		M	F	M	F	M	F	M	F	M	F	M	F	Total #	
		Foreman/Supervisor													
Asbestos Worker Journeyman															
Asbestos Worker Apprentice															
Boilermaker Journeyman															
Boilermaker Apprentice															
Bricklayer Journeyman															
Bricklayer Apprentice															
Carpenter Journeyman															
Carpenter Apprentice															
Cement Mason Journeyman															
Cement Mason Apprentice															
Electrician Journeyman															
Electrician Apprentice															
Elevator Constructor Journeyman															
Elevator Constructor Apprentice															
Glazier Journeyman															
Glazier Apprentice															
Iron Worker Journeyman															
Iron Worker Apprentice															
Laborer Journeyman															
Laborer Apprentice															
Operating Engineer Journeyman															
Operating Engineer Apprentice															
Painter Journeyman															
Painter Apprentice															
Pipe Fitter/Plumber Journeyman															
Pipe Fitter/Plumber Apprentice															
Plasterer Journeyman															
Plasterer Apprentice															
Roofer Journeyman															
Roofer Apprentice															
Sheet Metal Journeyman															
Sheet Metal Apprentice															
Sprinkler Fitter															
Sprinkler Fitter Apprentice															
Truck Driver Journeyman															
Truck Driver Apprentice															
Welder Journeyman															
Welder Apprentice															
Other															
Total Monthly Hours															
Total % of Hours															

Contractor shall submit report by the 15th of each month.

Phillip Yelder, Director Human Relations Department 414 E. 12th Street, 4th Floor, Kansas City, MO 64106 Phone: 816-513-1836 Email: HRDcontractcompliance@kcmo.org	Report Submitted By: _____ Date: _____
--	---

Affiant's signature

Subscribed and sworn to before me this _____ day of _____, 20____.

Notary Public

My Commission expires:



TABLE OF CONTENTS

Project/Contract Numbers: 60800073 / 9848

Project Title: WD Emergency Transmission Water Main Repair

INTRODUCTORY INFORMATION

00005	Certification Page
00010	Table of Contents

BIDDING REQUIREMENTS

00130	Invitation to Bid
00210	Instructions to Bidders
00410	Bid Form
00410.01	Experience Reference Form
00410.02	Experience and Reference Summary
00410.03	List of Equipment and Staffing
00410.04	Equipment Questionnaire
00411	Itemized Prices Form0
00412	Unit Prices
00430	Bid Bond
00440	CREO KC Form 5 Construction Contract Instructions
00450	CREO KC 08 CUP and Request for Waiver
00450.01	CREO KC Letter of Intent to Subcontract
00460	CREO KC 10 Timetable for MBE/WBE Utilization
00470	CREO KC 11 Request for Modification or Substitution
00485	CREO KC Monthly Reporting Instructions
00485.01	MWBE Monthly Utilization Report
00485.01.1	MWBE Monthly Utilization Report Instructions
00485.02	Project Specific Workforce Monthly Report
00485.02.1	Workforce Monthly Report Instructions
00485.03	Company-Wide Workforce Monthly Report
00485.04	CREO KC Construction Employee Identification Report Form
00485.05	Affidavit of Training Program
CREO 14	Affirmative Action Program Affidavit
CREOKC	Contract Closeout Approval
00490	Pre-Contract Bidder's Certification Form

CONTRACTING REQUIREMENTS

00515	Construction Contract Required Submissions
00515.01	Employee Eligibility Verification Affidavit
00560	Missouri Project Exemption Certificate
00560.01	Kansas City Missouri Tax Exempt Certificate
00610	Performance and Maintenance Bond Form
00615	Payment Bond Form
00620	Insurance Certificate Forms
00630	Revenue Clearance Release Authorization

00700	General Conditions
00800	Supplementary Conditions
00830	Wage Rate Requirements – Cass, Clay, Jackson, Platte, and Ray Counties
00910	Construction Addenda
00930	Request for Interpretation Form
00930.01	Request for Interpretation Form Log
00931	Supplemental Design Instructions
00932	Request for Proposal
00933	Request for Proposal Log
00940	Change Order Form
00945	Work Change Directive

DIVISION 1 - GENERAL REQUIREMENTS

01000	General Project Requirements
01016	Water Main near Sewer
01210.01	Allowance Authorization
01270	Measurement and Payment
01290.01	Application for Payment
01290.02	Schedule of Values
01290.09	Subcontractors and Major Material Suppliers List
01290.11	Daily Labor Force Report
01290.12	Certificate of Substantial Completion
01290.13	Punch List
01290.14	Contractor Affidavit for Final Payment
01290.15	Subcontractor Affidavit for Final Payment
01320.01	Daily Field Observation Report
01320.02	Periodic Field Observation Report
01320.03	Working Day Report
01330.01	Letter of Transmittal
01630	Substitution Request
01700	Traffic Regulations

DIVISION 2 – SITEWORK

02200	Excavation and Backfill
02250	Trenching, Pipe Embedment and Backfill
02320	Utility Casings Water Main Construction
02575	Surface Restoration
02608	Concrete Vaults
02618	Ductile Iron Pipe Water Main General
02645	Hydrants, Blow off and Flushing Assemblies
02669	Thrust Restraints
02675	Water Main Testing, Disinfection & Dechlorination
02930	Seeding
02931	Sodding

DIVISION 3 – CONCRETE

03001	Concrete
03100	Concrete Formwork
03200	Concrete Reinforcement

DIVISIONS 4 – 16 Not Used

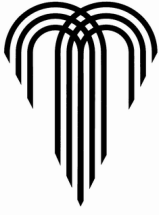

INVITATION TO BID

Project/Contract Number 60800073/9848

Project Title Water Department Emergency Transmission Water Main Repair

The General Service Department of Kansas City, Missouri will receive sealed Bids until **2:00 PM, on Tuesday, April 2, 2024** at 4800 E. 63rd Street, (1st) floor Shoal Creek Conference Room, Kansas city, Missouri 64130 for **Project/Contract No. 60800073/9848 – Water Department Emergency Transmission Water Main Repair**. Bids will be opened after that time at this location

City desires that Minority Business Enterprises (MBE) and Women's Business Enterprises (WBE) have a maximum opportunity to participate in the performance of City contracts. The goals for this specific Project are (11%) MBE participation and (11%) WBE participation.

Bidding Documents will be available online to all interested parties at the Kansas City, Missouri Plan Room, <http://www.kcmoplanroom.org>. All addenda will be posted at this location. Any document or plan may be viewed or downloaded from this location.

Project Manager: Jason Wright
Phone Number: (816) 513-4772
E-mail: jason.wright@kcmo.org

Contract Administrator: Angela Bennett
Phone Number: (816) 513-0247
E-mail: angela.bennett@kcmo.org

View all procurement and contracting opportunities at <http://www.kcmo.gov>



ADDENDUM NUMBER 2

Project Number: 60800073/9848

Project Title WD- Emergency Transmission Water Main Repair

ISSUE DATE: 03/12/2024

Bidders are hereby notified that the Bidding and Contract Documents for the above project, for which Bids are to be received on 04/02/2024 @ 2:00pm, are amended as follows:

Information to Bidders The following is provided to Bidders for information only:

Q1.	Does this project have any renewals?
A1.	Yes, there are four renewal options on this project. Shown in Addendum 2 00410 Construction Bid Form.
Q2.	Is this bid limited to certified Small Local Business Enterprise (SLBE) entities?
A2.	No, Addendum 1 removed that limitation. Shown in Addendum 1 00130 Invitation to Bid Form.
Q3.	Is there a maximum obligation of the City for this project?
A3.	Yes, the maximum obligation amount is \$1,650,000.00. Shown in Addendum 2 00410 Construction Bid Form.

Bidding Requirements

1. Delete and replace the following section:
 - a. Delete Document 00410, Construction Bid Form, and replace with the following Document, 00410, Construction Bid Form.

NOTE: Bidders must acknowledge receipt of this Addendum by listing the number and date, where provided, on the Bid Form - Document 00410.

Bidder: _____

CITY OF FOUNTAINS
HEART OF THE NATION

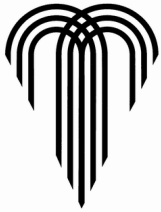

KANSAS CITY
MISSOURI

BID FORM/CONTRACT

ADDENDUM 2

Project/Contract Numbers: 60800073/9848

Project Title: WD Emergency Transmission Water Main Replacement

1. Bidder, having examined the Bidding Documents, related documents and the Site of the Work, and being familiar with all the conditions affecting the construction of the proposed Work, including Laws and Regulations and the availability of materials and supplies, agrees, if this Bid is selected by CITY, this Bid Form/Contract will become the Contract between Bidder and CITY for Bidder to furnish all labor and materials, equipment and services necessary for the proper completion of the Work in accordance with the Contract Documents, including general construction work at the price(s) stated below, which stated sums include fees and all other charges applicable to materials, appliances, labor and all things subject to and upon which other charges may be levied.
2. Bidder agrees the Contract Documents will comprise the entire agreement between CITY and Bidder. The Contract Documents are identified in the General Conditions and are incorporated into and made part hereof this Bid Form/Contract by reference.
3. Bidder agrees that if this Bid Form/Contract is executed by CITY, Bidder's offer is accepted and this Bid Form/Contract that incorporates all other Contract Documents shall constitute the Contract between the parties. Bidder authorizes the CITY to fill in the Contract Price on this Bid Form/Contract in accordance with Bidder's Bid. Bidder agrees that this Bid Form/Contract may be executed in one or more counterparts, each of which will be deemed an original copy of this Bid Form/Contract and all of which, when taken together, will be deemed to constitute one and the same Bid Form/Contract. This Bid Form/Contract shall be effective upon the execution of counterparts by both parties, notwithstanding that both parties may not sign the same counterpart. The parties' signatures transmitted by facsimile or by other electronic means shall be proof of the execution of this Bid Form/Contract and shall be acceptable in a court of law. A copy of this Bid Form/Contract shall constitute an original and shall be acceptable in a court of law.
4. The maximum obligation of the CITY for the Work is \$1,650,000.00, includes Unit Prices. The sum of the extensions of the Unit Prices for is \$_____. The actual number of units worked and paid for under this Contract may be more or less than the estimated Quantity given or may be none.
5. The Bidder agrees to enter into Four (4) successive renewals to this Contract if so requested by the CITY. The determination to renew the contract will be at the sole discretion of the CITY where such renewal would be in the best interest of the CITY and subject to the availability and appropriation of funds. An increase in a unit price, if any, will be determined solely by the CITY, and if needed, will not exceed the change in the Consumer Price Index for the period since the Contract was signed.
6. The undersigned Bidder agrees that this Bid shall remain subject to selection by CITY, and may not be withdrawn for ninety (90) days after the day Bids are opened.
7. The undersigned Bidder certifies that this Bid contains no modifications, deviations, riders or qualifications.
8. The undersigned Bidder acknowledges receipt of the following addenda listed by number and date appearing on each addendum:

Addendum Number	Dated	Addendum Number	Dated
(_____)	(_____)	(_____)	(_____)

Bidder: _____

(_____) (_____) (_____) (_____)
(_____) (_____) (_____) (_____)
(_____) (_____) (_____) (_____)
(_____) (_____) (_____) (_____)
(_____) (_____) (_____) (_____)
(_____) (_____) (_____) (_____)

- 9. By submitting its bid, Bidder is agreeing to meet or exceed the minimum employment goals of 10% minority and 2% women during the term of its contract with the City, or request a waiver of the goals. If a waiver is requested, Bidder must establish good faith efforts towards meeting the goals as set forth in the CREO KC Instructions for Construction Contracts and the City’s Construction Employment Program Ordinance (commonly known as the “Workforce Ordinance”) (City Code Section 3-515). Within forty-eight (48) hours after bid opening, the construction contractor shall submit CREO KC Employee Identification Report Form, which shall include: the name, home address, job title, sex and race/ethnicity of each person the contractor anticipates will be performing construction labor hours creditable towards the minimum workforce goals applicable to the construction contractor individually.
10. Should Bidder fail to meet or exceed the minimum employment goals or otherwise establish that Bidder is entitled to a waiver under circumstances in which Bidder has previously failed to meet or exceed the goals on one or more occasions with the twenty-four month period immediately preceding the completion of the Work under this Bid Form/Contract, Bidder may be suspended from participating, either as a contractor or subcontractor, on any future contract with the City for a period ranging from thirty days to six months as further specified in the Contract Documents. This program is distinguished from the M/WBE Program in that it is not based on company ownership but rather is based on workforce hours instead of a budgetary allocation of work.
11. By submitting its bid, Bidder warrants that if its bid should exceed \$300,000.00 and Bidder employs fifty (50) or more people, Bidder has an affirmative action program in place and will maintain the affirmative action program in place for the duration of its contract with the City. Bidder further warrants that it will comply with the affirmative action requirements contained in the General Conditions as incorporated by reference into this Bid Form/Contract.
12. Section 15 through Section 18 constitutes the Affidavit of Intended Utilization required to be submitted by Bidders.
13. By submitting its bid, Bidder is agreeing to the following: (1) Bidder has made by bid opening a good faith effort to meet the MBE/WBE/DBE goals established for the project; or Bidder will continue to make during the 48 hours after bid opening a good faith effort to meet the MBE/WBE/DBE goals established for the project; and (2) Bidder will timely submit its 00450 CREO KC 08 Contractor Utilization Plan/Request for Waiver and 00450.01 CREO KC Letter of Intent to Subcontract for each MBE/WBE listed on the 00450 CREO KC 8 Construction Contractor Utilization Plan/Request for Waiver; and (3) Bidder will submit documentation of its good faith efforts to meet the MBE/WBE/DBE goals when requested by the City. Failure to meet these requirements in good faith will result in Bidder forfeiting its bid bond.

PROJECT GOALS: 11% MBE 11% WBE 0% DBE

BIDDER PARTICIPATION: _____% MBE _____% WBE _____% DBE

Bidder: _____

14. To the best of Bidder's knowledge, the following are names of certified MBEs and/or WBEs with whom Bidder, or Bidder's subcontractors, presently intend to contract with if awarded the Contract on the above project: **(All firms must currently be certified by Kansas City, Missouri Civil Rights & Equal Opportunity – CREO KC – Department)**

A. Name of M/WBE Firm _____
Address _____
Telephone No. _____
I.R.S. No. _____
Area/Scope of work _____
Subcontract amount _____

B. Name of M/WBE Firm _____
Address _____
Telephone No. _____
I.R.S. No. _____
Area/Scope of work _____
Subcontract amount _____

C. Name of M/WBE Firm _____
Address _____
Telephone No. _____
I.R.S. No. _____
Area/Scope of work _____
Subcontract amount _____

D. Name of M/WBE Firm _____
Address _____
Telephone No. _____
I.R.S. No. _____
Area/Scope of work _____
Subcontract amount _____

E. Name of M/WBE Firm _____
Address _____
Telephone No. _____
I.R.S. No. _____
Area/Scope of work _____
Subcontract amount _____

F. Name of M/WBE Firm _____
Address _____
Telephone No. _____
I.R.S. No. _____
Area/Scope of work _____
Subcontract amount _____

(List additional MBE/WBEs, if any, on additional pages and attach to this form)

15. By submitting its bid, Bidder is agreeing it will identify and timely submit within 48 Hours after Bid opening those MBE/WBE subcontractors with dollar amounts and scopes of work, which apply to or exceed the MBE/WBE goals for the Project on the **00450 CREO KC 08 Contractor Utilization Plan/Request for Waiver**.

Bidder: _____

16. Bidder agrees that failure to meet or exceed the MBE/WBE Goals for the above project will require the Director of the Civil Rights & Equal Opportunity (CREO KC) Department to recommend disapproval of the bid unless the Director of CREO KC finds the Bidder established good faith efforts towards meeting the goals as set forth in the CREO KC Forms and Instructions for Construction Projects and the City's MBE/WBE Ordinance.

Bidder: _____

Business Entity Type:

- Missouri Corporation
- Foreign Corporation
- Fictitious Name Registration
- Sole Proprietor
- Limited Liability Company
- Partnership
- Joint Venture
- Other: (Specify) _____

BIDDER

Legal name & address of Bidder, person firm, partnership, corporation, or association submitting Bid:

Phone No: _____

Cell No: _____

Facsimile No: _____

Bidder's E-Mail: _____

Federal ID. No. _____

I hereby certify that I have authority to execute this document on behalf of Bidder, person, firm, partnership, corporation or association submitting Bid.

By: _____
(Signature)

(Print Name)

Title: _____

Date: _____

(Attach corporate seal if applicable)

NOTARY

Subscribed and sworn to before me this _____ day of _____, 20__.

My Commission Expires: _____

Bidder: _____

ACCEPTANCE OF BID

CITY, by executing this Bid Form/Contract, hereby accepts Bidder's Bid and this Bid Form/Contract that incorporates all other Contract Documents shall constitute the Contract between the Parties.

CITY shall pay CONTRACTOR for completion of the Work in accordance with the Contract Documents a maximum amount of One Million Six Hundred Fifty Thousand Dollars and No/100, (\$1,650,000,.00). The Contract Price includes:

00412 Unit Prices, included in the Bid, a copy of which is attached

By executing this Bid Form/Contract, CITY accepts Bidder's offer for the Contract Price stated above and this Bid Form/Contract that incorporates all other Contract Documents shall constitute the Contract between the parties

City of Kansas City, Missouri (OWNER or City)

Approved as to form:

Assistant City Attorney

I hereby certify that there is a balance, otherwise unencumbered, to the credit of the appropriation to which the foregoing expenditure is to be charged, and a cash balance, otherwise unencumbered, in the treasury, to the credit of the fund from which payment is to be made, each sufficient to meet the obligation hereby incurred.

Director of Finance

(Date)



ADDENDUM NUMBER 3

Project/Contract Numbers: 60800073/9848

Project Title WD- Emergency Transmission Water Main Repair

ISSUE DATE: 03/21/2024

Bidders are hereby notified that the Bidding and Contract Documents for the above project, for which Bids are to be received on 04/02/2024 @ 2:00pm, are amended as follows:

Information to Bidders The following is provided to Bidders for information only:

Q4.	How many Crews will be utilized at one time?
A4.	We expect for there to be one crew on full time doing scheduled work and up to two additional crews periodically when needed for emergency repairs. Management will give notice to the contractor at least 24 hours ahead of time, how many crews will be required to be on-call per 24 hour period. The contractor will be notified in advance during extreme weather (hot or cold) to have additional crews available when the number of water main and/or service breaks exceed the usual and customary number.

Bidding Requirements

NOTE: Bidders must acknowledge receipt of this Addendum by listing the number and date, where provided, on the Bid Form - Document 00410.



CERTIFICATION PAGE

Project/Contract Number: 60800073/9848

Project Title: Water Department Emergency Transmisslon Water Main Repair

I am responsible for the following specifications and drawings:

Drawings:

Specifications: DIV 2 and 3

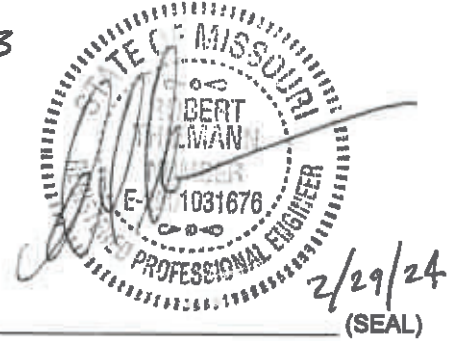

I am responsible for the following specifications and drawings:

Drawings:

Specifications:

(SEAL)

I am responsible for the following specifications and drawings:

Drawings:

Specifications:

(SEAL)

I certify under penalty of law that the document and all attachments were prepared under my direction or supervision in accordance with a system designed to assure that qualified personnel properly gathered and evaluated the information submitted, and that the information submitted is, to the best of my knowledge and belief, true, accurate, and complete. I am aware that there are significant penalties for submitting false information, including the possibility of fine and imprisonment for knowing violations.



TABLE OF CONTENTS

Project/Contract Numbers: 60800073 / 9848

Project Title: WD Emergency Transmission Water Main Repair

INTRODUCTORY INFORMATION

00005	Certification Page
00010	Table of Contents

BIDDING REQUIREMENTS

00130	Invitation to Bid
00210	Instructions to Bidders
00410	Bid Form
00410.01	Experience Reference Form
00410.02	Experience and Reference Summary
00410.03	List of Equipment and Staffing
00412	Unit Prices
00430	Bid Bond
00440	HRD 5: Construction Contract HRD Instructions
00450	HRD 8: Contractor Utilization Plan/Request for Waiver
00450.01	Letter of Intent to Subcontract
00460	HRD 10: Timetable for MBE/WBE Utilization
00470	HRD 11: Request for Modification or Substitution
00485	HRD Monthly Reporting Instructions HRD Employee Identification Report Form HRD Affidavit of Training Program
00490	Pre-Contract Bidder's Certification Form

CONTRACTING REQUIREMENTS

00515	Construction Contract Required Submissions
00515.01	Employee Eligibility Verification Affidavit
00560	Missouri Project Exemption Certificate
00560.01	Kansas City Missouri Tax Exempt Certificate
00610	Performance and Maintenance Bond Form
00615	Payment Bond Form
00620	Insurance Certificate Forms
00630	Revenue Clearance Release Authorization
00700	General Conditions
00800	Supplementary Conditions
00830	Wage Rate Requirements – Cass, Clay, Jackson, Platte, and Ray Counties
00910	Construction Addenda
00930	Request for Interpretation Form
00930.01	Request for Interpretation Form Log
00931	Supplemental Design Instructions
00932	Request for Proposal
00933	Request for Proposal Log

00940 Change Order Form
00945 Work Change Directive

DIVISION 1 - GENERAL REQUIREMENTS

01000 General Project Requirements
01016 Water Main near Sewer
01210.01 Allowance Authorization
01270 Measurement and Payment
01290.01 Application for Payment
01290.02 Schedule of Values
01290.09 Subcontractors and Major Material Suppliers List
01290.11 Daily Labor Force Report
01290.12 Certificate of Substantial Completion
01290.13 Punch List
01290.14 Contractor Affidavit for Final Payment
01290.15 Subcontractor Affidavit for Final Payment
01320.01 Daily Field Observation Report
01320.02 Periodic Field Observation Report
01320.03 Working Day Report
01330.01 Letter of Transmittal
01630 Substitution Request
01700 Traffic Regulations

DIVISION 2 – SITEWORK

02200 Excavation and Backfill
02250 Trenching, Pipe Embedment and Backfill
02320 Utility Casings Water Main Construction
02575 Surface Restoration
02608 Concrete Vaults
02618 Ductile Iron Pipe Water Main General
02645 Hydrants, Blow off and Flushing Assemblies
02669 Thrust Restraints
02675 Water Main Testing, Disinfection & Dechlorination
02930 Seeding
02931 Sodding

DIVISION 3 – CONCRETE

03001 Concrete
03100 Concrete Formwork
03200 Concrete Reinforcement

DIVISIONS 4 – 16 Not Used



INVITATION TO BID

Project/Contract Number 60800073/9848

Project Title Water Department Emergency Transmission Water Main Repair

The General Service Department of Kansas City, Missouri will receive sealed Bids until **2:00 PM, on Tuesday, April 2, 2024** at 4800 E. 63rd Street, (1st) floor Shoal Creek Conference Room, Kansas city, Missouri 64130 for **Project/Contract No. 60800073/9848 – Water Department Emergency Transmission Water Main Repair**. Bids will be opened after that time at this location

This Invitation for Bid is limited to those entities that are certified by the City as Small Local Business Enterprise (SLBE) or that have applied for certification as a SLBE at least 45 days prior to the date of this solicitation and who will have received that certification by the date on which the bid is due. Any bid received from any entity not having submitted a timely application or not certified as a SLBE on the due date shall be rejected and will not be considered.

City desires that Minority Business Enterprises (MBE) and Women's Business Enterprises (WBE) have a maximum opportunity to participate in the performance of City contracts. The goals for this specific Project are (11%) MBE participation and (11%) WBE participation.

Bidding Documents will be available online to all interested parties at the Kansas City, Missouri Plan Room, <http://www.kcmoplanroom.org>. All addenda will be posted at this location. Any document or plan may be viewed or downloaded from this location.

Project Manager: Jason Wright
Phone Number: (816) 513-4772
E-mail: jason.wright@kcmo.org

Contract Administrator: Angela Bennett
Phone Number: (816) 513-0247
E-mail: angela.bennett@kcmo.org

View all procurement and contracting opportunities at <http://www.kcmo.gov>



INSTRUCTIONS TO BIDDERS

Project/Contract Number: 60800073/9848

Project Title: Water Department Emergency Transmission Water Main Repair

1. Sealed Bids for **Project/Contract Number 60800073/9848 - Water Department Emergency Transmission Water Main Repair**, will be received by the Water Department at 4800 E. 63rd Street Kansas City, Missouri until **2:00 P.M., April 2, 2024** at which time bidding will be closed.

- a. All Bids will be opened and read aloud. The Bid Envelope must contain all required submissions to be included with the Bid. No Bid may be withdrawn for a period of ninety (90) days after the Bid is opened. Bid security shall likewise continue for the same ninety (90) days unless earlier released by the City. The successful Bidder shall comply with all Bidding and contract requirements. Bids, once opened and read, may not be withdrawn without forfeiture of the Bid security.
- b. All Bids shall be addressed to the **Manager of Procurement Services**, shall state on the outside of the sealed Bid envelope “Bid Enclosed”, title and Project number, and shall be deposited in the locked Bid box. All Bids must comply with the Bidding Requirements of Kansas City, Missouri (CITY).

2. Consideration of Bids

- a. The City will determine the lowest, responsive and responsible Bid. The City may reject any or all bids. If the City rejects all Bids, the City may: (1) resolicit Bids following the City’s normal solicitation procedure; or (2) solicit Bids only from those Bidders that submitted a Bid pursuant to the original solicitation; or (3) use an expedited Bid submission schedule with or without readvertising or issuing any other public notice when the City determines that the delay from the normal City solicitation procedure would not be in the City's best interests.
- b. Alternates. If this solicitation includes Bid Alternates, the City, in its sole discretion, may include any, all or none of the Alternates in determining the lowest, responsive and responsible Bid. In determining lowest, responsive and responsible Bid, the City may include the Alternates in any combination and in any order or priority or choose none of the Alternates. The City may make this determination at any time after Bid Closing and prior to Contract award. The City will act in the best interest of the City in determining whether to include any, all or none of the Alternates and the combination and priority of any Alternates selected. If additional funding becomes available after Contract award, City may add any or all of the Alternates to the Contract by change order.

3. Evidence of Competency to Perform. Each bidder shall furnish with the bid satisfactory evidence of Bidder’s competency to perform the proposed work. Such evidence of competency shall consist of the following:

- a. Completed Form 00410.01 Experience Reference Summary for three projects of similar scope performed within the past 5 years including the name, address and telephone number of the contact person having knowledge of the project and the dollar value of the project.
- b. Statement that, during the three (3) years immediately preceding the date of the Bid, Bidder has received no written notices of violations of any federal or state prevailing wage statute in which prevailing wage penalties were assessed against the Bidder or Bidder has been found in such but has made restitution to affected workmen and complied with any statutory penalty; and a

statement that Bidder is current on payment of Federal and State income tax withholdings and unemployment insurance payments

- c. Statement that Bidder participates in a training program that facilitates entry into the construction industry and which may include an on-the-job or in-house training program. By submitting its Bid, Bidder is agreeing to timely submit during the 48 hours after Bid opening an affidavit of describing such program and Bidder's participation.
- d. Identify the following Key Personnel proposed for the Project. (**NOTE:** Key Personnel must be committed to the Project for its duration, and may not be removed or substituted without the City's prior written consent.)
 - (1) GC Project Manager
 - (2) On-Site Field Superintendent
 - (3) QC/QA Manager
 - (4) Safety Officer
- e. For each of the Key Personnel, provide the following background information.
 - (1) Years of employment with current employer
 - (2) City of residence
 - (3) Identify any other projects this person will be involved with concurrently with the Project, and state the time commitment for the Project and each other project
 - (4) Discuss professional registrations, education, certifications, and credentials held by this person that are applicable to the Project
- f. Discuss generally the tasks involved in the Project.
- g. Illustrate clearly and concisely Bidder's understanding of the technical elements that must be addressed for successful completion of the Project.
- h. Submit a bid schedule with anticipated milestones for the Project using Microsoft Project 2007 or later format.
- i. Describe key issues that might affect the Project schedule and how Bidder proposes to address them.
- j. Summary of the Project Safety Plan for the Project.
 - (1) Describe how Bidder proposes to address any unique safety issues for the Project
 - (2) Describe your safety record and environmental compliance record along with your Firm's OSHA reportable accident rates on recent comparable size projects
 - (3) Statement of Bidder's Experience Modification Ratio (EMR)
- k. Discuss Bidder's understanding of the traffic control required for the Project, if applicable, and how traffic control will impact the Project schedule. Discuss any major traffic control issues that need to be addressed and Bidder's proposed solutions.
- l. Identify any other special issues or problems that are likely to be encountered. Outline the manner in which Bidder suggests resolving them.
- m. Outline key community relations issues and how they might be resolved.
- n. Describe any difficulties Bidder anticipates encountering in serving the City, in light of the City's status as a municipality and public entity. Explain how Bidder plans to manage them.
- o. Summary of Bidder's Quality Assurance/Quality Control Plan for this project
- p. Statement regarding all work performed two (2) years immediately preceding the date of the Bid, that contains either (a) a contract by contract listing of any written notices of violations of any

federal, state or local DBE/MBE/WBE Program and any damages assessed; or (b) a statement that there have been no such written notices of violations or such penalties assessed; and a statement that Program requirements have been met.

- q. Statement that the Bidder has not been rescinded or debarred from any bidding, contractual, procurement, or other such programs by federal, state or local entities.
- r. Statement that Bidder is current on payment of Federal and State income tax withholdings and unemployment insurance payments
- s. Statement of Bidder's litigation and/or arbitration history over the past five (5) years including final ruling.
- t. Statement of Bidder's bond history over the past five (5) years including any incidences of failure to perform.
- u. MBE / WBE past project performance and compliance with participation goals in comparable size commercial projects
- v. Other.

4. Waiver of Bid Requirements The City Manager or his delegate at any time may waive any requirements imposed by this solicitation or by any City regulation when failure to grant the waiver will result in an increased cost to the City and the requirement waived would be waived for all Bidders for this solicitation and it is in the best interest of the City to grant the waiver. The City Council at any time may waive any requirements imposed in this solicitation by the City's Code of Ordinances when it finds failure to grant the waiver will result in an increased cost to the City and the waived requirement would be waived for all Bidders for this solicitation and it is in the best interest of the City to grant the waiver. The City reserves the right to waive any irregularities and/or formalities as deemed appropriate.

5. Late Bids Bids and modifications of Bids received after the exact hour and date specified for receipt will not be considered unless: (1) the Bid is sent via the U.S. Postal Service, common carrier or contract carrier, by a delivery method that guarantees the Bid will be delivered to the City prior to the submission deadline; or (2) if the Bid is submitted by mail, common carrier or contract carrier it is determined by the City that the late receipt was due solely to an error by the U.S Postal Service, common carrier or contract carrier; or (3) the Bid is timely delivered to the City but is at a different City location than that specified in this IFB; or (4) the City extends the time after the deadline for a force majeure event that could potentially affect any or all Bidders meeting the deadline.

6. Interpretations and Addenda All questions about the meaning or intent of the Bidding Documents may be directed to the Project Manager listed at the end of these Instructions to Bidders. Interpretations or clarifications considered necessary by the Project Manager in response to such questions will be issued by Addenda to all parties recorded as having received the Bidding Documents. Questions received less than ten (10) days prior to the date for opening of Bids may not be answered. Only answers issued by formal written Addenda will be binding. Oral and other interpretations or clarifications will be without legal effect. Addenda may also be issued to modify the Bidding Documents as deemed advisable by the City.

7. Bid Security Requirements All Bids submitted must be accompanied by a Bid deposit in the amount of five percent (5%) of the base Bid which shall be in the form of a Bid Bond (on the form provided in these Bidding Documents), Cashier's Check, Letter of Credit, Certificate of Deposit or other instrument approved in advance by the City. Prior to submittal of the Bid the City Treasurer must approve both the financial institution and text of a Letter of Credit. A Cashier's Check or a Certificate of Deposit shall be payable to the City Treasurer.

8. Forfeiture of Security If a Bidder fails or refuses to execute the Contract when requested by the City, any Bid security given to the City shall immediately become due and payable and forfeited to the City as liquidated damages.

9. Mistake in Bid Security By submitting a Bid, Bidder is agreeing to correct any mistakes on a Bid security submission when requested by the City. When such a mistake occurs and a Bidder fails or

refuses to correct the mistake or execute the Contract when requested by the City, any Bid security shall be forfeited to the City and the Bidder shall also be subject to debarment and damages.

10. Bids that Exceed the Engineer's Estimate The City may offer the apparent lowest, responsive and responsible Bidders the option of performing the Work for the Engineer's estimate for the Project with no changes to the Bid requirements or scope of the Project if the Bid is not more than five percent higher than the Engineer's estimate.

11. Post Bid Required Submissions The successful Bidder will be required to submit the following documents with the signed copies of the Bid Form/Contract or within the timeframes specified in the Notice of Intent to Contract letter. Copies of the City's forms that the successful Bidder will be required to sign are bound into this Project Manual for information:

- a. Properly signed, dated, and sealed Performance and Maintenance Bond and Payment Bond;
- b. Properly completed certificates of insurance;
- c. Copies of licenses required by the City to do the Work;
- d. A copy of CONTRACTOR's current Certificate of Good Standing or Fictitious Name Registration from the Missouri Secretary of State, or other acceptable proof; and

12. Indemnification – City of Kansas City. The contract documents contains a requirement that Contractor shall indemnify, defend and hold harmless the City and any of its agencies, officials, officers, or employees from and against all claims, damages, liability, losses, costs, and expenses, including reasonable attorneys' fees, arising out of or resulting from any acts or omissions in connection with the contract, caused in whole or in part by Contractor, its employees, agents, or Subcontractors, or caused by others for whom Contractor is liable, including negligent acts or omissions of the City, its agencies, officials, officers, or employees. The contract requires Contractor to obtain specified limits of insurance to insure the indemnity obligation. Contractor has the opportunity to recover the cost of the required insurance in the Contract Price by including the cost of that insurance in the Bid amount.

13. Indemnification – State of Missouri. The contract documents contains a requirement that Contractor shall indemnify, defend and hold harmless the Missouri Highways and Transportation Commission (MHTC) and the Missouri Department of Transportation (MoDOT) and their respective employees from and against all claims, damages, liability, losses, costs, and expenses, including reasonable attorneys' fees, arising out of or resulting from any acts or omissions in connection with the contract, caused in whole or in part by Contractor, its employees, agents, or Subcontractors, or caused by others for whom Contractor is liable. The contract requires Contractor to obtain specified limits of insurance to insure the indemnity obligation. Contractor has the opportunity to recover the cost of the required insurance in the Contract Price by including the cost of that insurance in the Bid amount.

14. City's Buy American and Missouri Preference Policies It is the policy of the City that any manufactured goods or commodities used or supplied in the performance of any City contract or any subcontract thereto shall be manufactured or produced in the United States whenever possible. When Bids offer quality, price, conformity with specifications, term of delivery and other conditions imposed in the specifications that are equal, the City shall select the Bid that uses manufactured goods or commodities that are manufactured or produced in the United States. The City shall give preference to all commodities manufactured, produced, or grown within the State of Missouri and to all firms, corporations, or individuals doing business as Missouri firms, corporations or individuals, when quality is equal or better and delivered price is the same or less. It is the bidder's responsibility to claim these preferences.

15. Affirmative Action It is the policy of the City that any person or entity entering into a contract with the City, will employ applicants and treat employees equally without regard to their race, color, sex, religion, national origin or ancestry, disability, sexual orientation, gender identity or age. Bidder will be required to comply with the City's Affirmative Action ordinance if Bidder is awarded a contract from the City totaling more than \$300,000.00. If you have any questions regarding the City's Affirmative Action requirements, please contact CREO KC at (816) 513-1836 or visit the City's website at www.kcmo.gov.

16. Tax Clearance Bidder will be required to furnish to CITY sufficient proof from City's Commissioner of Revenue, verifying that Bidder is in compliance with the license and tax ordinances administered by City's Revenue Division as a precondition to CITY making its first payment under any CONTRACT over \$160,000.00. Bidder will also be required to obtain proof of City tax compliance from all of its Subcontractors prior to the Subcontractors performing any Work.

17. Substitutions or "Or-Equal" Items The procedure for submission of substitutions or "or-equal" items is set forth in the General Conditions and Supplementary Conditions.

18. Prevailing Wage Requirements The successful Bidder shall pay the prevailing hourly rate of wages as determined by the Missouri Annual Wage Order and/or Federal Wage Determination set forth in the Project Manual. In case of a conflict between Missouri and Federal wage rates, the higher rate shall apply.

Successful Bidder shall be required to use City's Internet web based Prevailing Wage Reporting System provided by City and protocols included in that software during the term of this Contract. When requested by the City, Bidder shall submit user applications to City's provided Prevailing Wage Reporting System for all applicable personnel and shall require subcontractors to submit same.

19. Contract Information Management System. Successful Bidder shall be required to use City's Internet web based Contract Information Management System/Project Management Communications Tool provided by City and protocols included in that software during the term of this Contract. Bidder/Proposer shall submit user applications to City's provided Contract Information Management System for all personnel, subcontractors or suppliers as applicable.

20. MBE/WBE Program Requirements City desires that Minority Business Enterprises (MBE) and Women's Business Enterprises (WBE) have a maximum opportunity to participate in the performance of City contracts. The goals for this specific Project are (11%) MBE participation and (11%) WBE participation. The City's CREO KC Forms and CREO KC Instructions for Construction Projects are incorporated into these Bidding Documents and the Contract Documents. The MBE/WBE Directory is available on the City's website at www.kcmo.gov. Please call the Civil Rights and Equal Opportunity Department at (816) 513-1836 for assistance.

Successful Bidder shall be required to use City's Internet web based MBE/WBE Program Reporting System provided by City and protocols included in that software during the term of this Contract. When requested by the City, Bidder shall submit user applications to City's provided MBE/WBE Program Reporting System for all applicable personnel and shall require subcontractors/subconsultants to submit same.

21. Waiver of MBE/WBE Requirements The City Council may waive any and all MBE/WBE requirements imposed by any Bidding Document or the MBE/WBE Ordinance and Contract with the lowest, responsive and responsible Bidder if the City Council determines a waiver is in the best interests of the City.

22. Forfeiture of Bid Bond for Failure to Make MBE/WBE Submissions By submitting its Bid, Bidder is agreeing to the following: (1) Bidder has made by Bid opening a good faith effort to meet the MBE/WBE goals established for the Project; or Bidder will continue to make during the 48 hours after Bid opening a good faith effort to meet the MBE/WBE goals established for the Project; and (2) Bidder will timely submit its 00450 CREO KC Construction Contractor Utilization Plan/Request for Waiver (CREO KC Form 8) and 00450.01 Letter of Intent to Subcontract for each MBE/WBE listed on the 00450 CREO KC Construction Contractor Utilization Plan/Request for Waiver; and (3) Bidder will submit documentation of its good faith efforts to meet the MBE/WBE goals when requested by the City. Failure to meet these requirements in good faith will result in Bidder being debarred and forfeiting its Bid Bond.

23. Workforce Program Requirements. City desires that minorities and women have a maximum opportunity to practice their trades on city construction projects. The minimum company-wide goals are a ten percent (10%) minority workforce and two percent (2%) women workforce. The City's CREO KC Forms and CREO KC Instructions for Construction Projects are incorporated into these Bidding Documents and the Contract Documents.

Successful Bidder shall be required to use City's Internet web based Workforce Program Reporting System provided by City and protocols included in that software during the term of this Contract. When

requested by the City, Bidder shall submit user applications to City's provided Workforce Program Reporting System for all applicable personnel and shall require subcontractors to submit same.

24. Subcontractors, Suppliers and Others

a. If the Contract Documents require the identity of certain Subcontractors, Suppliers and other persons and organizations (including those who are to furnish the principal items of material and equipment) to be submitted to City, the apparent lowest, responsive and responsible Bidder, and any other Bidder so requested, shall submit to City a list of all such Subcontractors, Suppliers and other persons and organizations proposed for those portions of the Work for which such identification is required. An experience statement shall accompany such list with pertinent information regarding similar projects and other evidence of qualification for each such Subcontractor, Supplier or organization if requested by City. If City has reasonable objection to any proposed Subcontractor, Supplier or other person or organization, City may request the apparent lowest, responsive and responsible Bidder to submit an acceptable substitute without an increase in Bid price.

b. By submitting its Bid, Bidder agrees that it has read and understands all the provisions of General Condition No. 6.07, Concerning Subcontractors, Suppliers and Others, and that it will comply with all those provisions including but not limited to mandatory mediation of disputes and the prohibition against paid-if-paid and paid-when-paid contract clauses. It is the City's expectation that all Subcontractors and Suppliers will be treated fairly and in good faith by the successful Bidders and that the successful Bidder will make all reasonable efforts to resolve contract disputes with a Subcontractor or Supplier in a prompt and fair manner. If the City is notified by a Subcontractor or Supplier of a contract claim with the successful Bidder, City will notify the successful Bidder and will request prompt resolution of the claim. City will provide any such Subcontractor or Supplier information regarding mandatory mediation as well as a copy of the Payment Bond. City may notify the Surety that City has taken cognizance of such claim.

c. In accordance with the Missouri Prompt Payment Act, City reserves the right to withhold payment(s) in good faith from the successful Bidder due to: i) the successful Bidder's failure to comply with any material provision of the contract; ii) third party claims filed or reasonable evidence that a claim will be filed; iii) the successful Bidder's failure to make timely payments for labor, equipment or materials; or iv) for damage to a Subcontractor or Supplier.

d. By submitting its Bid, Bidder agrees it will not deny any Subcontractor subcontracting opportunities solely because the Subcontractor is not a signatory to collective bargaining agreements with organized labor.

e. The provisions of GC 6.07 are a material term of the Contract with the City and failure by the successful Bidder to comply with the provisions of this section will be taken into consideration by City in making the determination of lowest, responsive and responsible bidder in any subsequent City contracts.

25. Signatures Each copy of the Bid Form/Contract must be signed and properly dated by the following, as applicable:

Limited Liability Company:

- a member of the limited liability Company authorized to sign on behalf of the company.

Partnership:

- a partner authorized to sign on behalf of the partnership.

Sole Proprietor:

- the proprietor.

Joint Venture:

- the parties to the Joint Venture authorized to sign on behalf of each party to the Joint Venture, or a person authorized by each party to the Joint Venture to sign on behalf of all parties to the Joint Venture.

Corporation:

- a corporate office authorized to sign on behalf of the corporation. Corporation's seal must be attached to the signature.

26. Forward all questions in writing to the following Project Manager and Contract Administrator. Questions received less than three (3) days prior to the Bid Date may not be answered. Interpretations or clarifications considered necessary by the Project Manager in response to such questions will be issued by Addenda to all Bidders. Oral or other interpretations or clarifications shall be without legal effect, even if made at a Pre-Bid Meeting.

Jason Wright, Project Manager
Water Services Department
4800 E. 63rd Street
Kansas City, MO 64130
(816) 513-4772
E-mail: Jason.wright@kcmo.org

Angela Bennett, Contract Administration
General Services Department
Procurement Services Division
4800 E. 63rd St.
Kansas City, Mo 64130
(816) 513-0247
E-mail: angela.bennett@kcmo.org



For persons with disabilities needing reasonable accommodations please contact Jaime Guillen at 816-513-9982. If you need to use the Relay Missouri Center call 1-800-RELAY-MO (1-800-735-2966).

Bidder: _____

Area/Scope of work _____
Subcontract amount _____

B. Name of M/WBE Firm _____
Address _____
Telephone No. _____
I.R.S. No. _____
Area/Scope of work _____
Subcontract amount _____

C. Name of M/WBE Firm _____
Address _____
Telephone No. _____
I.R.S. No. _____
Area/Scope of work _____
Subcontract amount _____

D. Name of M/WBE Firm _____
Address _____
Telephone No. _____
I.R.S. No. _____
Area/Scope of work _____
Subcontract amount _____

E. Name of M/WBE Firm _____
Address _____
Telephone No. _____
I.R.S. No. _____
Area/Scope of work _____
Subcontract amount _____

F. Name of M/WBE Firm _____
Address _____
Telephone No. _____
I.R.S. No. _____
Area/Scope of work _____
Subcontract amount _____

(List additional MBE/WBEs, if any, on additional pages and attach to this form)

15. By submitting its bid, Bidder is agreeing it will identify and timely submit within 48 Hours after Bid opening those MBE/WBE subcontractors with dollar amounts and scopes of work, which apply to or exceed the MBE/WBE goals for the Project on the **00450 CREO-KC 08 Contractor Utilization Plan/Request for Waiver**.
16. Bidder agrees that failure to meet or exceed the MBE/WBE Goals for the above project will require the Director of Human Relations to recommend disapproval of the bid unless the Director of Civil Rights and Equal Opportunity finds the Bidder established good faith efforts towards meeting the goals as set forth in the CREO-KC Forms and Instructions for Construction Projects and the City's MBE/WBE Ordinance.

Bidder: _____

Business Entity Type:

- Missouri Corporation
- Foreign Corporation
- Fictitious Name Registration
- Sole Proprietor
- Limited Liability Company
- Partnership
- Joint Venture
- Other: (Specify) _____

BIDDER

Legal name & address of Bidder, person firm, partnership, corporation, or association submitting Bid:

Phone No: _____

Cell No: _____

Facsimile No: _____

Bidder's E-Mail: _____

Federal ID. No. _____

I hereby certify that I have authority to execute this document on behalf of Bidder, person, firm, partnership, corporation or association submitting Bid.

By: _____
(Signature)

(Print Name)

Title: _____

Date: _____

(Attach corporate seal if applicable)

NOTARY

Subscribed and sworn to before me this _____ day of _____, 20__.

My Commission Expires: _____

Bidder: _____

ACCEPTANCE OF BID

CITY, by executing this Bid Form/Contract, hereby accepts Bidder's Bid and this Bid Form/Contract that incorporates all other Contract Documents shall constitute the Contract between the Parties.

CITY shall pay CONTRACTOR for completion of the Work in accordance with the Contract Documents a maximum amount of _____ Dollars, (\$ _____). The Contract Price includes:

00412 Unit Prices, included in the Bid, a copy of which is attached

By executing this Bid Form/Contract, CITY accepts Bidder's offer for the Contract Price stated above and this Bid Form/Contract that incorporates all other Contract Documents shall constitute the Contract between the parties

City of Kansas City, Missouri (OWNER or City)

Approved as to form:

Assistant City Attorney

I hereby certify that there is a balance, otherwise unencumbered, to the credit of the appropriation to which the foregoing expenditure is to be charged, and a cash balance, otherwise unencumbered, in the treasury, to the credit of the fund from which payment is to be made, each sufficient to meet the obligation hereby incurred.

Director of Finance

(Date)



EXPERIENCE AND REFERENCE SUMMARY

Project/Contract Numbers: 60800073/9848

Project Title: Water Department Emergency Transmission Water Main Repair

Firm's Legal Name	
Mailing Address	
Contact – Name & Email	
Contact – Phone & Fax	

NO.	PROJECT & LOCATION	OWNER NAME & ADDRESS CONTACT & PHONE NUMBER	PROJECT DURATION & DATE COMPLETED	\$ VALUE
1.				
2.				
3.				
4.				
5.				
6.				
7.				
8.				
9.				



EXPERIENCE AND REFERENCE SUMMARY – CURRENT PROJECTS

Project/Contract Numbers: 60800073/9848

Project Title: Water Department Emergency Transmission Water Main Repair

Page ____ of ____

Firm's Legal Name	
Mailing Address	
Contact – Name & E-Mail	
Contact – Phone & Fax	

NO.	PROJECT & LOCATION	CONTRACT AMOUNT/ % COMPLETE	OWNER NAME & ADDRESS CONTACT & PHONE NUMBER	LENGTH, DIAMETER & MATERIAL OF CONSTRUCTION OR DESCRIPTION OF REPAIRS	START DATE
1.					
2.					
3.					
4.					
5.					
6.					
7.					
8.					



LIST OF EQUIPMENT AND STAFFING AVAILABLE FOR PROJECT

Project/Contract Numbers: 60800073/9848

Project Title: Water Department Emergency Transmission Water Main Repair

Page ____ of ____

	EQUIPMENT AVAILABLE FOR CONSTRUCTION (OR ATTACH LIST)		STAFFING BREAKDOWN	NUMBER OF EACH CATEGORY
1.		1.	OFFICE STAFF	
2.		2.	SUPERVISORS	
3.		3.	FIELD STAFF – CREW FOREMEN	
4.		4.	FIELD STAFF – OPERATORS (NOT FOREMEN)	
5.		5.	FIELD STAFF – LABORERS (NOT FOREMEN)	
6.		6.		



UNIT PRICES

Project /Contract Number: 60800073/9848

Project Title: Emergency Transmission Water Main Repair

NOTE: IN THE EVENT OF DISCREPANCY, UNIT PRICE SHALL GOVERN.

Item No.	Unit	Quantity	Item Description:	Unit Price	Extension
1	Hour	50	Two-Person Crew for Related Work w/o Excavation		\$ -
2	Hour	25	Two-Person Crew for Related Work w/o Excavation - Regular Over-time		\$ -
3	Hour	5	Two-Person Crew for Related Work w/o Excavation - Double Over-time		\$ -
4	Hour	150	Two-Person Crew for Repair/Replacements		\$ -
5	Hour	50	Two-Person Crew for Repair/Replacements - Regular Over-time		\$ -
6	Hour	25	Two-Person Crew for Repair/Replacements - Double Over-time		\$ -
7	Hour	800	Three-Person Crew for Repair/Replacements		\$ -
8	Hour	75	Three-Person Crew for Repair/Replacements - Regular Over-time		\$ -
9	Hour	30	Three-Person Crew for Repair/Replacements - Double Over-time		\$ -
10	Hour	200	Four-Person Crew for Repair/Replacements		\$ -
11	Hour	50	Four-Person Crew for Repair/Replacements - Regular Over-time		\$ -
12	Hour	25	Four-Person Crew for Repair/Replacements - Double Over-time		\$ -
13	Ton	500	Granular Embedment (One-Half-Inch Clean Rock)		\$ -
14	Ton	300	Untreated Aggregate Backfill		\$ -
15	Hour	50	Waste Material, Disposal - Single Axle Dump Truck		\$ -
16	Hour	100	Waste Material, Disposal - Tandem Axle Dump Truck		\$ -
17	Cu. Yd	200	Concrete		\$ -
18	Cu. Yd	250	Diggable Flowable Fill		\$ -
19	Each	30	Weekday On-call Per Crew (24 hour period)		\$ -
20	Each	190	Weekend/ Holiday On-call Per Crew (24 hour period)		\$ -
21	Hour	50	Two-Person Crew For Grade and Seed		\$ -
22	Cu. Yd	25	Topsoil		\$ -
23	Each	12	Monthly Project Superintendence		\$ -
24	Each	TBD	Specialized Traffic Control		
25	Each	TBD	Street Plates		
26	Each	TBD	Materials Not Available from Owner's Stores		
27	Each	TBD	Other Specialized or Unique Services, Labor, Equipment		
			Total Unit Prices: (LAST PAGE ONLY)		TOTAL \$
					\$ -

Note: May be printed, for manual fill-in, or filled in on electronic excel spreadsheet version.

Updated 5-25-21



BID BOND

Project Number 60800073

Project Title Water Department Emergency Transmission Water Main Repair

Bond Number _____

KNOW ALL MEN BY THESE PRESENTS: That _____ of _____, as Principal, and _____ as Surety, hereby bind themselves, their heirs, executors, administrators, successors and assigns, jointly and severally, firmly by these presents unto KANSAS CITY, MISSOURI, a constitutionally chartered municipal corporation, as Obligee, in the sum of _____ Dollars (\$ _____), lawful money of the United States.

WHEREAS, Principal is herewith submitting its Bid to enter into a contract with Kansas City for the above referenced project,

NOW, THEREFORE the condition of this obligation is such that if the Principal is awarded the contract the Principal will, within the time required, enter into a contract and give a good and sufficient surety bonds to secure the performance of the terms and conditions of the contract and for the prompt payment of all labor and material furnished in the prosecution thereof as required by the contract documents, then this obligation shall be void; otherwise the Principal and Surety will immediately pay unto the Obligee the full amount of this bond as liquidated damages for failure to fulfill the conditions of this obligation, but in no event shall the Surety's liability exceed the penal sum hereof.

Signed, sealed and delivered this _____ day of _____.

BIDDER AND PRINCIPAL

Name, address and facsimile number of Bidder and Principal

I hereby certify that I have authority to execute this document on behalf of Bidder and Principal.

By: _____

Title: _____

(Attach corporate seal if applicable)

SURETY

Name, address and facsimile number of Surety:

I hereby certify that (1) I have authority to execute this document on behalf of Surety; (2) Surety has an A.M. Best rating of A- or better; (3) Surety is named in the current list of "Companies Holding Certificates of Authority as Acceptable Sureties on Federal Bonds and as Acceptable Reinsuring Companies" as published in Circular 570 (most current revision) by the Financial Management Service, Surety Bond Branch, U.S. Department of the Treasury; and (4) Surety is duly licensed to issue bonds in the State of Missouri and in the jurisdiction in which the Project is located.

By: _____

Title: _____

Date: _____

(Attach seal and Power of Attorney)

**CREO KC INSTRUCTIONS
FOR CONSTRUCTION CONTRACTS**

PART A. ECONOMIC EQUITY & INCLUSION GOALS--MBE/WBE PROGRAM

I. City's Economic Equity & Inclusion Goals--MBE/WBE Program.

- A. The City has adopted an Economic Equity & Inclusion Goals--Minority/Women Business Enterprise ("MBE/WBE") Program (Sections 3-421 through 3-469, Code of Ordinances) (the "Program") to implement the City's policy of supporting the fullest possible participation in City contracts and change orders of firms owned and controlled by minorities and women. Each construction contract may have an MBE and/or WBE goal for participation. An MBE or WBE goal is a numerical objective the City has set for the contract that may be awarded pursuant to these bid specifications. Goals are stated as a percentage of contract dollars. For example, if an MBE goal for a contract is 10% and a Bidder submits a bid of \$100,000, the goal for MBE participation would equal \$10,000. The specific MBE/WBE goals on this contract are set forth elsewhere in the bid specifications.
- B. These Civil Rights & Equal Opportunity Department ("CREO KC") Forms & Instructions are part of the BIDDING DOCUMENTS and CONTRACT DOCUMENTS as defined in the General Conditions. By submitting a Bid, the Bidder agrees, as a material term of the contract, to carry out the City's MBE/WBE Program by making good faith efforts to include certified MBE/WBEs in the contract work to the extent of the goals listed for the contract and to the fullest extent consistent with submitting the lowest and best bid to the City. Bidder agrees that the Program is incorporated into this document and agrees to follow the Program. Although it is not a requirement that a Bidder in fact meet or exceed both the MBE and WBE Goals, it is a requirement for approval of the Bid that a Bidder objectively demonstrate to the City that good faith efforts have been made to meet the Goals. Bidders must attempt to meet both the MBE and WBE goals and request a waiver if either is not met.
- C. The following CREO KC Forms are attached and must be used for MBE/WBE submittals:
1. Contractor Utilization Plan/Request for Waiver (CREO KC Form 8); and
 2. Letter of Intent to Subcontract (CREO KC Form 00450.01); and
 3. Timetable for MBE/WBE Utilization (CREO KC Form 10); and
 4. Request for Modification or Substitution (CREO KC Form 11); and
 5. Contractor Affidavit for Final Payment (Form 01290.14); and
 6. Subcontractor Affidavit for Final Payment (Form 01290.15).

Warning: The City only gives MBE/WBE credit for a Bidder's use of City certified MBE/WBEs. A certified MBE/WBE firm is a firm that has been certified by the City's Civil Rights & Equal Opportunity Department as such. An MBE/WBE firm must be certified before the date on which the contractor utilization plan is due. Certified MBEs and WBEs are listed in the M/W/DBE Kansas City Mo. Online Directory, which is available on the City's website at www.kcmo.org. Before a Bidder submits a bid, Bidder



should contact CREO KC and consult the directory to make sure any firm proposed for use for MBE/WBE participation has been certified.

II. Required Submissions Following Bid Opening.

A. Bidder must submit the following documents within forty-eight (48) hours of bid opening:

1. **Contractor Utilization Plan/Request for Waiver (CREO KC Form 8).** This form states a Bidder's plan to use specific certified MBE/WBEs in the performance of the contract and includes the following:
 - a. The work to be performed by each MBE/WBE and the amounts each is to be paid for the work; and
 - b. The name, address, race or ethnic origin, gender and employer identification number or social security number of each MBE/WBE that will perform the work.
 - c. An automatic request for waiver in the event Bidder has not met or exceeded the MBE and/or WBE goals for the contract but believes that it has made good faith efforts to meet or exceed the goals and desires a waiver of the goals. If a waiver is requested, CREO KC will examine the Bidder's documentation of good faith efforts and make a recommendation to grant or deny the waiver. CREO KC will recommend a waiver be granted only if the Bidder has made good faith efforts to obtain MBE/WBE participation.
2. **Letter(s) of Intent to Subcontract (CREO KC Form 00450.01).** A letter must be provided from each MBE/WBE listed on the Contractor Utilization Plan. These letters verify that the MBE/WBE has agreed to execute a formal agreement for the work and indicate the scope of work to be performed and the price agreed upon for the work.

III. Required Submission when Requested by City.

A. Bidder must submit the following documents when requested by City:

1. **Timetable for MBE/WBE Utilization (CREO KC Form 10).**
2. **Documentation of good faith efforts.**

IV. Required Monthly Submissions during term of Contract.

A. Bidder must submit the following report on a monthly basis if awarded the contract:

1. **M/WBE Monthly Utilization Report.** This report must be submitted to the Director by the 15th of each month. Failure to submit timely reports may result in delays in processing of current and future contract approvals and payment applications. The method of submission of this report is through the B2GNow Diversity Management System (B2GNow).

V. Required Submittals for Final Contract Payment.

A. Contractor must submit the following documents with its request for final payment under

the contract:

1. **Contractor Affidavit for Final Payment (Form 01290.14)**
2. **Subcontractor Affidavit(s) for Final Payment (Form 01290.15)**
3. **Final B2GNow Monthly Contract Audit Report with all payment audits confirmed.**

VI. Additional Submittals.

- A. Contractor may be required to make additional submittals during the term of the Contract, including **Request for Modification or Substitution (CREO KC Form 11)**. Refer to Section IX, Modification of the Contractor Utilization Plan or Substitution of an MBE/WBE, for additional instructions on when this form must be submitted.

VII. MBE/WBE Participation Credit.

- A. The following shall be credited towards achieving the goals:
 1. The total contract dollar amount that a prime contractor has paid or is obligated to pay to a subcontractor that is a certified MBE or WBE, except as otherwise expressly provided for herein.
 2. The total contract dollar amount that a prime contractor that is a certified MBE or WBE performed itself.
 3. Sixty percent (60%) of the total dollar amount paid or to be paid by a prime contractor to obtain supplies or goods from a supplier who is a certified MBE or WBE.
 4. Ten percent (10%) of the total dollar amount paid or to be paid by a prime contractor to obtain supplies or goods from a supply broker who is a certified MBE or WBE.
 5. One hundred percent (100%) of the total dollar amount paid or to be paid by a prime contractor to a manufacturer of construction supplies who is a certified MBE or WBE.
 6. Subcontractor participation with a lower tier MBE/WBE subcontractor using one of the above methods of participation.
- B. **NO CREDIT**, however, will be given for the following:
 1. Participation in a contract by a MBE or WBE that does not perform a commercially useful function as defined by the Program; and
 2. Any portion of the value of the contract that an MBE or WBE subcontractor subcontracts back to the prime contractor or any other contractor who is not a qualified MBE/WBE; and
 3. Materials and supplies used on the contract unless the MBE/WBE is responsible for negotiating the price, determining quality and quantity, ordering the materials and installing (where applicable) and paying for material itself; and
 4. Work performed by an MBE or WBE in a scope of work other than that in which the MBE or WBE is currently certified.

VIII. Methods for Securing Participation of MBE/WBEs and Good Faith Efforts.

- A. A bidder is required to make good faith efforts to achieve the MBE/WBE goals. Good faith efforts are efforts that, given all relevant circumstances, a Bidder actively and aggressively seeking to meet the goals can reasonably be expected to make. Good faith efforts must be made before the Bidder submits a Contractor Utilization Plan, in other words, within 48 hours of bid opening. However, efforts made to increase participation of MBEs and WBEs following submission of the CUP can be considered as evidence of good faith efforts to meet the goals.
- B. In evaluating good faith efforts, the Director of CREO KC will consider whether the Bidder has performed the following, along with any other relevant factors:
 - 1. Advertised for at least 15 calendar days prior to the bid or proposal due date opportunities to participate in the contract in general circulation media, trade and professional association publications, small and minority business media, and publications of minority and women's business organizations which are included in a list along with their current contact information identified on the directory as the list of publications available to publish such advertisements, which list shall be updated by CREO KC no less than every three (3) month.
 - 2. Sent written notices at least fifteen (15) calendar days prior to the bid or proposal due date containing the information required in section (9) below, by certified mail, e-mail, or facsimile, to at least 80% of MBEs and WBEs which are included in a list along with their contact information identified on the directory as the list of organizations available to receive such notices, which list shall be updated by CREO KC no less than every three (3) months.
 - 3. Sent written notices, containing the information required by section (9) below, by certified mail, e-mail or facsimile, to at least 80% of MBEs and WBEs listed on the directory certified in the applicable scopes of work for the particular bid soliciting their participation in the contract at least 15 calendar days prior to the bid or proposal due date.
 - 4. Attempted to identify portions of the work for qualified MBE and/or WBE participation in order to increase the likelihood of meeting the goals, including breaking down contracts into economically feasible units that take into consideration the capacity of available MBE/WBEs appearing on the CREO KC directory.
 - 5. At any time prior to submission of the CUP or submittal of a request for modification of a CUP, requested assistance in achieving the goals from the Director and acted on the Director's recommendations.
 - 6. Conferred with certified MBEs and WBEs which inquired about or responded to the bid solicitation and explained to such MBEs and WBEs the scope and requirements of the work for which their bids or proposals were solicited, and if not all certified MBEs and WBEs in the particular scopes listed on the directory have inquired about or responded to the bid solicitation for each scope of work, then contact by certified mail, e-mail or telephone the greater of ten (10) or 80% of additional certified MBEs and WBEs in the particular scopes of work listed on the directory and offer to confer with such MBEs and WBEs for such particular scope of work and request such MBEs

and WBEs to submit a proposal.

7. Attempted to negotiate in good faith with certified MBEs and WBEs which responded to the bid solicitation or those certified MBEs and WBEs that were conferred with as contemplated in section (6) above, and other qualified MBEs and WBEs, at the option of the bidder, proposer, or contractor, as applicable, to perform specific subcontracts, not rejecting them as unqualified without sound reasons based on a thorough investigation of their capabilities by the bidder, proposer, or contractor; in the event an MBE or WBE is the low bid, but rejected as unqualified, the bidder, proposer, or contractor and the director or board, as applicable, shall provide sound reasons for rejecting such MBE or WBE.
8. Attended pre-bid meeting when such meetings were indicated in the solicitation of bids or otherwise by the bidder, proposer, or contractor, as applicable or by the director provided the director provides written direction to the bidder, proposer, or contractor at the time the goals are recommended.
9. Written notices and advertisements to be provided pursuant to sections (1), (2) and (3) above shall include the following information:
 - a. The bid due date;
 - b. The name of the project;
 - c. The address or general location of the project;
 - d. The location of plans and specifications for viewing;
 - e. Contact information of the prime contractor;
 - f. A general description of the scopes of work that are the subject of the solicitation;
 - g. The goals established for the applicable contract, and if the goals are still subject to board approval, then a statement that the goals as stated are preliminary and are subject to board approval;
 - h. If the project or any portion of the project is subject to prevailing wage then a statement that all or a portion of the project will be subject to prevailing wage, as applicable; and if only a portion of the scopes are subject to prevailing wage, then identification of such scopes provided that such scopes are known as of the time of bid solicitation;
 - i. The date and time of any pre-bid meeting(s), if any, which have been scheduled by the bidder, proposer, contractor or developer as of the bid solicitation; and

Any other information deemed relevant by the bidder, proposer, contractor or developer, as applicable, or the director to the extent the director provides written direction to the bidder, proposer, contractor or developer of such additional information at the time the goals are recommended by the director. 8. Within five (5) working days after drawing the bid specifications, send certified letters, verifiable e-mails or proof of facsimiles to certified MBEs and WBEs listed in the M/W/DBE Kansas City Mo. Online Directory.

- C. A Bidder may be required to give the City documentation to prove that it made good faith efforts. The Bidder will be contacted by the City with further instructions about when this documentation must be submitted.

IX. Modification of the Contractor Utilization Plan or Substitution of an MBE/WBE.

- A. After bid opening, a Bidder or Contractor may need to substitute an MBE and/or WBE or request that the amount of MBE/WBE participation listed in its Contractor Utilization Plan be modified. Bidder or Contractor must file a **Request for Modification or Substitution (CREO KC Form 11) prior to actual substitution and within a reasonable time after learning that a modification or substitution is necessary.** The Director may approve substitutions or modifications and upon approval, the modifications and substitutions will become an amendment to the Contractor Utilization Plan. Modifications or substitutions may be approved when:
 - 1. The Director finds that the Bidder or Contractor made and provided evidence of good faith efforts to substitute the MBE/WBE listed on the Contractor Utilization Plan with other certified MBE/WBEs for the scope of work or any other scope of work in the contract; and
 - 2. The Bidder or Contractor has not attempted intentionally to evade the requirements of the program and it is in the best interests of the City to allow a modification or substitution; and
 - 3. The Director also finds one of the following:
 - a. The listed MBE/WBE is non-responsive or cannot perform; or
 - b. The listed MBE/WBE has increased its previously quoted price to the bidder, proposer or contractor without a corresponding change in the scope of the work; or
 - c. The listed MBE/WBE has committed a material default or breach of its contract with the contractor; or
 - d. Requirements of the scope of work of the contract have changed and render subcontracting not feasible or not feasible at the levels required by the goals established for the contract; or
 - e. The listed MBE/WBE is unacceptable to the contracting department; or
 - f. The listed MBE/WBE thereafter had its certification revoked; or
- B. A modification shall not be made unless the modification or substitution has first been requested and approved by the Director. Once a modification has been made, a Construction Contractor Employee Identification Report (CREO KC Form 0485.04) for the newly approved subcontractor must be submitted at least ten (10) days prior to the approved subcontractor commencing work on a City contract.

X. Appeals.

- A. In conformance with the Act, appeals may be made to the City Fairness in Construction Board or Fairness in Professional Services and Goods Board on the following:

1. The grant or denial of a Request for Waiver;
 2. Substitution for an MBE/WBE listed on a Contractor Utilization Plan;
 3. Modification of the percentage of MBE/WBE participation on a Contractor Utilization Plan;
 4. Liquidated Damages;
 5. The amount of MBE/WBE credit the Contractor may receive for MBE/WBE participation identified in the contractor utilization plan.
- B. Any appeal must be filed in writing with the Director within fifteen (15) calendar days of notice of the determination. Mailing, faxing, personal delivery or posting at CREO KC of determinations shall constitute notice. The appeal shall state with specificity why the Bidder or Contractor believes the determination is incorrect
- C. Failure to file a timely appeal shall constitute a waiver of a Bidder's or Contractor's right to appeal such determination and such person shall be estopped to deny the validity of any determination which could have been timely appealed.

XI. Access to Documents and Records.

- A. By submitting a Bid, each Bidder agrees to permit the City, its duly authorized agents or employees, access at all reasonable times to all books and business records of Bidder as may be necessary to ascertain compliance with the requirements of this document and the Act, within ten (10) calendar days of the date of the written request.
- B. All Bidders agree to cooperate with the contracting department and CREO KC in studies and surveys regarding the MBE/WBE program.

XII. Miscellaneous.

- A. A Bidder or Contractor shall bear the burden of proof with regard to all issues on appeal.
- B. In the event of any conflict between this document and the Program, the provisions of the Program shall control. The terms used in this document are defined in the Program.
- C. Oral representations are not binding on the City.
- D. The City Council may waive the requirements of this document and the Program and award the contract to the lowest and best bidder if the City Council determines a waiver is in the best interests of the City.
- E. The Director may grant extensions of time to Bidders to submit Letters of Intent to Subcontract (CREO KC Form 00450.01).

XIII. Liquidated Damages – Economic Equity & Inclusion Goals--MBE/WBE Program.

- A. If Contractor fails to achieve the MBE/WBE goals stated in its Contractor Utilization Plan, as amended, the City will sustain damages, the exact extent of which would be difficult or impossible to ascertain. Therefore, in order to liquidate those damages, the monetary difference between either (1) the amount of the MBE/WBE goals set forth in the Contractor Utilization Plan, as amended, or (2) the goals established (whichever is lower) and the amount actually paid to qualified MBEs and WBEs for performing a commercially useful function will be deducted from the Contractor's payments as

liquidated damages. In determining the amount actually paid to qualified MBEs and WBEs, no credit will be given for the portion of participation that was not approved by the Director, unless the Director determines that the Contractor acted in good faith. No deduction for liquidated damages will be made when, for reasons beyond the control of the Contractor, the MBE/WBE participation stated in the Contractor Utilization Plan, as amended and approved by the Director is not met.

PART B. CONSTRUCTION EMPLOYMENT PROGRAM REQUIREMENTS

IMPORTANT: This Part B is applicable to City construction contracts estimated by the City prior to solicitation as: (1) requiring more than 800 construction labor hours and (2) valued in excess of \$300,000.00. This program is distinguished from the M/WBE Program in that it is based on workforce hours of the Bidder and *all* its participating subcontractors rather than the actual contract value of work. The instructions herein detail the specifics related to this program. This program is in *addition* to the M/WBE program.

I. City's Construction Employment Program.

- A. The City has adopted a Construction Employment Program (Sections 3-501 through 3-525, Code of Ordinances) (the "Workforce Program" or "Program") to implement the City's policy of supporting the fullest possible utilization of minority and women workers in the construction industry.
- B. The minimum workforce goals are currently set by ordinance at 10% for minorities and 2% for women. These goals are separate from M/WBE goals. Public recognition may be provided if the bidder achieves at least twice the minimum participation.
- C. Construction contracts subject to the Workforce Program and the company-wide and project-specific workforce goals ("workforce goals") are those contracts to construct, reconstruct, improve, enlarge or alter any fixed work that is estimated by the City prior to solicitation to: (1) require more than 800 construction labor hours, (2) has estimated costs that exceed \$300,000.00, and (3) involve the expenditure of public funds.
- D. The successful bidder may meet company-wide goals by counting the bidder's utilization of minorities and women throughout the Kansas City metropolitan statistical area. In addition, the successful Bidder is responsible to ensure that it and its subcontractors cumulatively make good faith efforts to meet project-specific goals for utilization of minorities and women.
- E. These Civil Rights & Equal Opportunity Department ("CREO KC") Forms & Instructions are part of the BIDDING DOCUMENTS and CONTRACT DOCUMENTS as defined in the General Conditions. By submitting a Bid, the Bidder agrees, as a material term of the contract, to carry out the City's Construction Employment Program by making good faith efforts to utilize minority and women workers to the fullest extent consistent with submitting the lowest and best bid to the City. Bidder agrees that the Program is incorporated into this document and agrees to follow the Program. Although it is not a requirement that a Bidder in fact meet or exceed the construction employment goals to receive approval from CREO KC, a Bidder not doing so is required to

objectively demonstrate to CREO KC that good faith efforts have been made.

- F. The following reports are to be used for Construction Employment Program submittals:
1. Project Workforce Monthly Report
 2. Company-Wide Workforce Monthly Report

II. Required Submissions.

- A. Within forty-eight (48) hours after bid opening, the construction contractor shall submit the **Construction Employee Identification Report** (CREO KC Form 00485.04) and shall include: the name, home address, job title, sex and race/ethnicity of each person working for the Prime. The individuals to be listed on the form are those which the construction contractor *anticipates* will be performing construction labor hours creditable towards the minimum workforce goals applicable to the construction contractor individually.

The following circumstances also require the submission of a Construction Employee Identification Report:

- a. Prior to contract execution for those City construction contracts awarded pursuant to a request for proposals (RFP), the construction contractor shall submit a **Construction Employee Identification Report** (CREO KC Form 00485.04).
 - b. At least ten (10) days prior to the date upon which any subcontractor is to commence work under a City construction contract, the Prime shall submit a **Construction Employee Identification Report** (CREO KC Form 00485.04) for the subcontractor.
- B. The CREO KC Director has established the B2GNow Diversity Management System (“B2GNOW”) (an online reporting tool) as the preferred method for fulfilling reporting requirements of the Workforce Program. The CREO KC Director will allow paper submission in lieu of on-line submission if the on-line submission process presents a hardship to the contractor.
- C. Bidder must submit the following documents through B2GNow on a monthly basis if awarded the contract:
1. **Project Workforce Monthly Report.** This report is contract specific. This report must be submitted to the Director by the 15th of each month for the Contractor and each subcontractor. It will be utilized to report the Contractor’s own workforce compliance data with regard to the City’s construction contract. Failure to submit timely reports may result in delays in processing of current and future contract approvals and payment applications.
 2. **Company-Wide Workforce Monthly Report.** This report is not contract specific; it is used to report on the utilization of women and minorities, by trade, company-wide. This report must be submitted to the Director by the 15th of each month. It will be utilized to report the Contractor’s own workforce compliance data with regard to



every contract (both privately and publicly funded) that the Contractor has in progress throughout the Kansas City Metropolitan Statistical Area. Failure to submit timely reports may result in delays in processing of current and future contract approvals and payment applications.

III. Submittal Required for Final Contract Payment.

- A. The final Project Workforce Monthly Report(s) and Company-Wide Workforce Monthly Report must be submitted before final payment will be made and/or retainage released. Contractor shall note the submittal of the final reports by notation in the box entitled “Final Report”

IV. Methods for Securing Workforce Participation and Good Faith Efforts.

- A. A bidder is required to make good faith efforts to achieve the construction employment goals and ensure its subcontractors are making good faith efforts to achieve the construction employment goals. If a Bidder or its subcontractors will be unable to secure enough minority and female participation to meet or exceed the construction employment goals, a bidder must, within a reasonable time after so learning, request a waiver or modification of the goals by the Director of CREO KC. The Director will request evidence of the Bidder’s and its’ subcontractors’ good faith efforts to meet the goals. The Director will examine the Bidder’s request and the Bidder’s documentation of good faith efforts for itself and its subcontractors. The Director will examine the Bidder’s request and the Bidder’s documentation of good faith efforts and grant or deny a waiver or modification. The Director will grant a waiver or modification only if the Bidder has made good faith efforts to secure minority and female participation.

IMPORTANT: The Bidder’s subcontractors on a city construction contract must meet the workforce goals collectively. The bidder is responsible to ensure the subcontractors make good faith efforts to meet the workforce goals. Bidders are required to include language in its subcontracts that ensure the subcontractors make good faith efforts to meet or exceed the workforce goals.

- B. In evaluating good faith efforts, the Director will consider whether the Bidder and its subcontractors have performed the following:
 - 1. For those bidders that are not signatories to a collective bargaining agreement with organized labor:
 - a. Requested in writing the assistance of the Director with respect to efforts to promote the utilization of minorities and women in the workforce and acted upon the Director’s recommendations; and
 - b. Advertised in minority or women trade association newsletters and/or minority or women owned media at least 15 calendar days prior to the utilization of any construction services on the city construction contract and used terminology that sufficiently describes the work available, the pay scale, the application process, and anything else that one might reasonably be expected to be informed of relevant to the position being advertised; and
 - c. Maintained copies of each advertisement and a log identifying the publication and date of publication; and



- d. Conducted real and substantial recruitment efforts, both oral and written, targeting resident, minority and women community-based organization, schools with a significant minority student population, and training organizations serving the recruitment area; and
 - e. Established and maintained a current list of resident, minority and women recruitment sources, providing written notification to the recruitment sources of available employment opportunities, and maintained records of the notices submitted to the organizations and any responses thereto; and
 - f. Maintained a current file for the time period of the city construction contract with the name, address, and telephone number of each resident, minority and woman job applicant, the source of the referral, whether or not the person was hired, and in the event that the applicant was not hired, the reason therefore; and
 - g. Promoted the retention of minorities and women in its workforce with the goals of achieving sufficient annual hours for minorities and women to qualify for applicable benefits; and
 - h. Required by written contract that all subcontractors comply with the above efforts.
2. For those bidders that are signatories to collective bargaining agreements with organized labor:
- a. Requested in writing from each labor union representing crafts to be employed that:
 - i. the labor union make efforts to promote the utilization of residents of the City, minorities and women in the workforce; and
 - ii. the labor union identify any residents of the City, minorities and women in its membership eligible for employment; and
 - b. Collaborated with labor unions in promoting mentoring programs for journeypersons intended to assist minorities and women in increasing retention with the goals of achieving sufficient annual hours to qualify for applicable benefits; and
 - c. Maintained a current file with the name, address, and telephone number of each resident, minority and women worker identified by the labor union, whether or not the person was hired, and in the event the person was not hired, the reason therefore.
 - d. To the extent the good-faith efforts applicable to bidders that are signatories to collective bargaining agreements with organized labor conflict with the procedures implemented by the bidder in order to comply with the relevant bargaining agreement, the bidder shall substitute other procedures as may be approved by the Director in writing, in order to accomplish the purpose and intent of this section.

C. In the event workforce goals are not met or there is anticipation that goals will not be



met, a Bidder will be required to give the City documentation to prove that it and/or its subcontractors made good faith efforts. The Bidder will be contacted by the City with further instructions about when this documentation must be submitted.

V. Access to Documents and Records.

- A. By submitting a Bid, each Bidder agrees to permit the City, its duly authorized agents or employees, access at all reasonable times to all books and business records of Bidder as may be necessary to ascertain compliance with the requirements of this document and the Program, within ten (10) days of the date of the written request. Each bidder further agrees to require, if awarded the contract, that every subcontractor permit the City the same access to documents and records.
- B. All Bidders agree to cooperate with the contracting department and CREO KC in studies and surveys regarding the construction employment program.

VI. Appeals.

- A. In conformance with the Program, appeals may be made to the Construction Workforce Board on the following:
 - 1. Determinations by the Director that a contractor did not meet the construction employment goals and did not make a good faith effort to meet the goals;
 - 2. Recommendations by the Director to assess liquidated damages;
 - 3. Recommendation by the Director that a contractor be declared ineligible to receive any city construction contract for a period of time up to one year.
- B. Any appeal must be filed in writing with the Director within ten (10) working days of notice of the recommendation or determination. The appeal shall state with specificity why the Bidder or Contractor believes the recommendation or determination is incorrect.
- C. Failure to file a timely appeal shall constitute a waiver of a Bidder's or Contractor's right to appeal such determination or recommendation and such person shall be estopped to deny the validity of any order, determination, recommendation or action of CREO KC which could have been timely appealed.

VII. Miscellaneous.

- A. A Bidder or Contractor shall bear the burden of proof with regard to all issues on appeal.
- B. The successful bidder may be required to meet with the Director of CREO KC or the Director's designee for the purpose of discussing the construction employment program, the bidder's efforts to realize the goals, and any other problems and/or issues affecting the realization of the goals or the program in general.
- C. In the event of any conflict between this document and the Program, the provisions of the Program shall control. The terms used in this document are defined in the Program.
- D. Oral representations are not binding on the City.

VIII. Failure to Meet Workforce Goals

- A. If Contractor or its subcontractors fail to achieve the construction employment goals or make good faith efforts to achieve those goals without having previously obtained a

waiver or modification of those goals, the City will sustain damages, the exact extent of which would be difficult or impossible to ascertain. These damages are magnified if the failure to abide by the requirements of the Workforce Program is recurring. Therefore, if the directory finds that the contractor or subcontractor have not met, or made good faith efforts to meet, the construction employment goals for any quarter, the director may:

1. Assess liquidated damages against the construction contractor, as specified in the city construction contract;
2. Require the contractor to attend mandatory training, as specified in the construction contract;
3. Declare the contractor ineligible to receive any city construction contract or participate as a subcontractor under any city construction contract for a period of time up to six months, as specified in the construction contract.

IX. First Source Program

- A. The City has established a labor force recruiting program intended to assist contractors in identifying, interviewing and hiring qualified job applicants residing in Kansas City, Missouri. While the contractor awarded a City construction contract is not prohibited from hiring persons residing outside Kansas City, Missouri, the recruiting resource provided for herein (the “First Source Program”) must be utilized by the contractor subject to the construction employment goals as set forth in this **PART B, CONSTRUCTION EMPLOYMENT PROGRAM REQUIREMENTS**.
- B. The City utilizes the services of the Full Employment Council, Inc., to administer the First Source Program. The contractor shall contact the Full Employment Council within 48 hours of contract award, regardless of whether the contractor has any hiring needs at that time, and within 48 hours following any job vacancy which the contractor reasonably anticipates filling during the term of the City construction contract. The contractor shall comply with the First Source Program requirements as implemented by the Full Employment Council unless otherwise excused in writing by the Director of CREO KC for good cause shown. To ensure compliance with the First Source Program, the contractor shall contact those persons at the Full Employment Council responsible for administering the program, which may be identified by visiting their website at www.feckc.org and clicking on the link for KCMO First Source Hiring Program. The contractor shall not hire any individual to provide construction services on a City construction contract unless the contractor has met the requirements of the First Source Program.
- C. The contractor shall require that its subcontractors utilize the First Source Program to the same extent that the contractor is required to do so, and shall incorporate the requirements of this Section IX into every subcontract. Every subcontractor shall be required to contact the Full Employment Council within 48 hours of subcontract award, regardless of whether the subcontractor has any hiring needs at that time, and within 48 hours following any job vacancy which the subcontractor reasonably anticipates filling during the term of their subcontract on a City construction project.





CONTRACTOR UTILIZATION PLAN/REQUEST FOR WAIVER

Project Number _____

Project Title _____

(Department Project)

Department

(Bidder/Proposer)

STATE OF _____)

) ss

COUNTY OF _____)

I, _____, of lawful age and upon my oath state as follows:

1. This Affidavit is made for the purpose of complying with the provisions of the MBE/WBE submittal requirements on the above project and the MBE/WBE Program and is given on behalf of the Bidder/Proposer listed below. It sets out the Bidder/Proposer's plan to utilize MBE and/or WBE contractors on the project.
2. The project target goals are _____% MBE and _____% WBE.
3. Bidder/Proposer assures that it will utilize a minimum of the following percentages of MBE/WBE participation in the above project:

BIDDER/PROPOSER PARTICIPATION: _____% MBE _____% WBE

POST-BID/POST-RFP ESTIMATED BUDGET: \$ _____

4. The following are the M/WBE subcontractors whose utilization Bidder/Proposer warrants will meet or exceed the above-listed Bidder/Proposer Participation. Bidder/Proposer warrants that it will utilize the M/WBE subcontractors to provide the goods/services described in the applicable Letter(s) of Intent to Subcontract, copies of which shall collectively be deemed incorporated herein). (*All firms must currently be certified by Kansas City, Missouri*)

Name of M/WBE Firm _____

Address _____

Telephone No. _____

I.R.S. No. _____



Name of M/WBE Firm _____

Address _____

Telephone No. _____

I.R.S. No. _____

Name of M/WBE Firm _____

Address _____

Telephone No. _____

I.R.S. No. _____

Name of M/WBE Firm _____

Address _____

Telephone No. _____

I.R.S. No. _____

Name of M/WBE Firm _____

Address _____

Telephone No. _____

I.R.S. No. _____

Name of M/WBE Firm _____

Address _____

Telephone No. _____

I.R.S. No. _____

(List additional M/WBEs, if any, on additional page and attach to this form)

- 4. The following is a breakdown of the percentage of the total contract amount that Bidder/Proposer agrees to pay to each listed M/WBE:

MBE/WBE BREAKDOWN SHEET

MBE FIRMS:

Name of MBE Firm	Supplier/Broker/Contractor	Subcontract Amount*	Weighted Value** \$ 90.00	% of Total Contract
_____	_____	_____	_____	_____
_____	_____	_____	_____	_____
_____	_____	_____	_____	_____
_____	_____	_____	_____	_____
_____	_____	_____	_____	_____
_____	_____	_____	_____	_____
_____	_____	_____	_____	_____
_____	_____	_____	_____	_____



TOTAL MBE \$ / TOTAL MBE %: \$ _____ %

WBE FIRMS:

Name of WBE Firm	Supplier/Broker/Contractor	Subcontract Amount*	Weighted Value**	% of Total Contract
_____	_____	_____	_____	_____
_____	_____	_____	_____	_____
_____	_____	_____	_____	_____
_____	_____	_____	_____	_____
_____	_____	_____	_____	_____
_____	_____	_____	_____	_____
_____	_____	_____	_____	_____
_____	_____	_____	_____	_____
_____	_____	_____	_____	_____

TOTAL WBE \$ / TOTAL WBE %: \$ _____ %

*“Subcontract Amount” refers to the dollar amount that Bidder/Proposer has agreed to pay each M/WBE subcontractor as of the date of contracting and is indicated here solely for the purpose of calculating the percentage that this sum represents in proportion to the total contract amount. Any contract amendments and/or change orders changing the total contract amount may alter the amount due an M/WBE under their subcontract for purposes of meeting or exceeding the Bidder/Proposer participation.

**“Weighted Value” means the portion of the subcontract amount that will be credited towards meeting the Bidder/Proposer participation. See CREO KC Forms and Instructions for allowable credit and special instructions for suppliers.

- Bidder/Proposer acknowledges that the monetary amount to be paid each listed M/WBE for their work, and which is approved herein, is an amount corresponding to the percentage of the total contract amount allocable to each listed M/WBE as calculated in the MBE/WBE Breakdown Sheet. Bidder/Proposer further acknowledges that this amount may be higher than the subcontract amount listed therein as change orders and/or amendments changing the total contract amount may correspondingly increase the amount of compensation due an M/WBE for purposes of meeting or exceeding the Bidder/Proposer participation



6. Bidder/Proposer acknowledges that it is responsible for considering the effect that any change orders and/or amendments changing the total contract amount may have on its ability to meet or exceed the Bidder/Proposer participation. Bidder/Proposer further acknowledges that it is responsible for submitting a Request for Modification or Substitution if it will be unable to meet or exceed the Bidder/Proposer participation set forth herein.
7. If Bidder/Proposer has not achieved both the M/WBE goal(s) set for this Project, Bidder/Proposer hereby requests a waiver of the MBE and/or WBE goal(s) that Bidder/Proposer has failed to achieve
8. Bidder/Proposer will present documentation of its good faith efforts, a narrative summary detailing its efforts and the reasons its efforts were unsuccessful when requested by the City.
9. I hereby certify that I am authorized to make this Affidavit on behalf of the Bidder/Proposer named below and who shall abide by the terms set forth herein:

Bidder/Proposer primary contact: _____

Address: _____

Phone Number: _____

Facsimile number: _____

E-mail Address: _____

By: _____

Title: _____

Date: _____

(Attach corporate seal if applicable)

Subscribed and sworn to before me this _____ day of _____, 20____.

My Commission Expires: _____

Notary Public





LETTER OF INTENT TO SUBCONTRACT

Check one:	
Original LOI:	<input type="checkbox"/>
Updated LOI:	<input type="checkbox"/>

Project Name/Title _____
 Project Location/Number _____

PART I: Prime Contractor _____ agrees to enter into a contractual agreement with M/W/DBE Subcontractor _____ who will provide the following goods/services in connection with the above-reference contract: [Insert a brief narrative describing goods/services to be provided. Broad Categorizations (e.g., "electrical," "plumbing," etc.) or the listing of NAICS Codes in which M/W/DBE Subcontractor is certified are insufficient and may result in denial of this Letter of Intent to Subcontract.]

for an estimated amount of \$ _____ (or _____ % of the total estimated contract value.)

- M/WBE Vendor type:
- Subcontractor/manufacturer (counts as 100% of contract value towards goals)
 - Supplier (counts as 60% of the total dollar amount paid or to be paid by a prime contractor for supplies or goods towards goals)
 - Broker (counts as 10% of the total dollar amount paid or to be paid by a prime contractor for supplies or goods towards goals)

M/W/DBE Subcontractor is, to the best of Prime Contractor's knowledge, currently certified with the City of Kansas City's Civil Rights & Equal Opportunity Department to perform in the capacities indicated herein. Prime Contractor agrees to utilize M/W/DBE Subcontractor in the capacities indicated herein, and M/W/DBE Subcontractor agrees to work on the above-referenced contract in the capacities indicated herein, contingent upon award of the contract to Prime Contractor.

PART 2: This section is to be completed by the M/W/DBE subcontractor listed above. Please attach additional sheets as needed for more than one intended sub-tier contract. **IMPORTANT: Falsification of this document will result in denial and other remedies available under City Code.**

- Select one:
- The M/W/DBE Subcontractor listed above **IS NOT** subcontracting any portions of the above-stated scope of work(s). (Continue to Part 3.)
 - The M/W/DBE Subcontractor listed above **IS** subcontracting certain portions of the above stated scope of work(s) to:

(1) Company name: _____

Full address: _____
Street number and name City, State and Zip Code

Primary contact: _____
Name Phone

a) This subcontractor is (select one): MBE WBE DBE N/A

i: If this subcontractor is an M/W/DBE certified with the City of Kansas City, Missouri, a separate Letter of Intent must be attached to this document.

ii. If this subcontractor is NOT a certified M/W/DBE certified with the City of Kansas City, Missouri, the firm must still be listed for reporting purposes but a Letter of Intent is not required.

b) Scope of work to be performed: _____

c) The dollar value of this agreement is: _____





REQUEST FOR MODIFICATION OR SUBSTITUTION

(This Form **must** be submitted to CREO KC to request substitutions for an MBE/WBE listed in the Contractor Utilization Plan or for modification of the amount of MBE/WBE participation listed in the Contractor Utilization Plan. This Form shall be an amendment to the Contractor Utilization Plan.)

BIDDER/PROPOSER/CONTRACTOR: _____

ADDRESS: _____

PROJECT NUMBER OR TITLE: _____

AMENDMENT/CHANGE ORDER NO: (if applicable) _____

Project Goals:	_____ % MBE	_____ % WBE
Contractor Utilization Plan:	_____ % MBE	_____ % WBE

1. I am the duly authorized representative of the above Bidder/Contractor/Proposer and am authorized to request this substitution or modification on behalf of the Bidder/Contractor/Proposer.

2. I hereby request that the Director of CREO KC recommend or approve: (check appropriate space(s))

a. A substitution of the certified MBE/WBE firm _____,
(Name of new firm)
 to perform _____,
(Scope of work to be performed by new firm)

for the MBE/WBE firm _____ which is currently
(Name of old firm)
 listed on the Bidder's/Contractor's/Proposer's Contractor Utilization Plan to
 perform the following scope of work: _____.
(Scope of work of old firm)

b. A modification of the amount of MBE/WBE participation currently listed on the Bidder's/Contractor's/Proposer's Contractor Utilization Plan from
 _____ % MBE _____ % WBE *(Fill in % of MBE/WBE Participation currently listed on Contractor Utilization Plan)*

TO

_____ % MBE _____ % WBE *(Fill in New % of MBE/WBE Participation requested for Contractor Utilization Plan)*

- c. Attach 00450.01 Letter of Intent to Subcontract letter for each new MBE/WBE to be added.
- d. Attach a copy of the most recent 00485.01 or on-line M/WBE Monthly Utilization Report

3. Bidder/Contractor/Proposer states that a substitution or modification is necessary because: (check applicable reason(s))



The MBE/WBE listed on the Contractor Utilization Plan is non-responsive or cannot perform.

The MBE/WBE listed on the Contractor Utilization Plan has increased its previously quoted price without a corresponding change in the scope of work.

The MBE/WBE listed on the Contractor Utilization Plan has committed a material default or breach of its contract.

___ Requirements of the scope of work of the contract have changed and make subcontracting not feasible or not feasible at the levels required by the goals established for the contract.

___ The MBE/WBE listed on the Contractor Utilization Plan is unacceptable to the City contracting department.

___ Bidder/Contractor/Proposer has not attempted intentionally to evade the requirements of the Act and it is in the best interests of the City to allow a modification or substitution.

4. The following is a narrative summary of the Bidder's/Contractor's/Proposer's good faith efforts exhausted in attempts to substitute the MBE/WBE firm named above which is currently listed on the Contractor Utilization Plan with other qualified, certified MBE/WBE firms for the listed scope of work or any other scope of work in the project:

5. Bidder/Proposer/Contractor will present documentation when requested by the City to evidence its good faith efforts.

Dated: _____

(Bidder/Proposer/Contractor)

By: _____
(Authorized Representative)



CREO KC MONTHLY REPORTING INSTRUCTIONS

M/WBE Monthly Utilization Report Instructions

1. MBE/WBE Reporting applies to Contracts that have approved MBE/WBE goals assigned.
2. The City will utilize a web-based MBE/WBE Reporting System in the administration of this Contract. This web-based application database is a collaboration tool selected and provided by the City, which will allow Contractors and Consultants/Subcontractors and Subconsultants to enter data and report on compliance.

Prevailing Wage Certified Payroll Report Instructions

1. Prevailing Wage Certified Payroll Report applies to Contracts that include Prevailing Wage or Davis Bacon Provisions.
2. This web-based application database is provided by the City for reporting certified payrolls and other related prevailing wage data.
3. Computer Requirements: Minimum Intel Pentium® 4 Processor 2.4 GHz or equivalent processor with 512MB of RAM; recommended Centrino Duo® Processors 1.6 GHz or equivalent with 2GB of RAM, or higher.
 - a. Computer Operation System: Windows XP, Windows Vista, or Windows 7
 - b. Web Browser: Google Chrome
 - c. Connection Speed/Minimum Bandwidth: DSL, ADSL or T1 Line for transferring a minimum of 3 Mbps Downstream and 512 Kbps Upstream
4. City will assist Contractor in providing training of personnel and Subcontractor's personnel.
5. Contractor and Subcontractors shall have the responsibility for visiting the web site and entering data in on timely basis, and as necessary to be in compliance with Prevailing Wage Requirements included in their contracts.

Workforce Monthly Report Instructions

1. Workforce Monthly Reporting only applies to Construction Contracts greater than \$300,000 and greater than 800 projected labor hours.
2. The City will utilize a web-based Reporting System in the administration of this Contract. This web-based application database is a collaboration tool selected and provided by the City, which will allow Contractors and Subcontractors to enter data and report on Workforce compliance.



M/WBE Monthly Compliance Audit Online Reporting Instructions

PRIME INSTRUCTIONS:

The Prime's responsibility is to report payments made to subcontractors for the prior month.

1. Log into B2GNow Diversity Management System (B2GNow)
2. On the Dashboard, click Contract Audits.
3. Select the specific audit that needs to be completed. Any and all money that changed hands during the month of the audit must be reported to the specific audit month.
4. To complete audit select Report 1 Subcontractor Payment. Under the actions column, select Submit Response for the specific subcontractor that needs reporting or select the Submit ALL Incomplete Records button to go to all the subcontractors to report amounts. Under the audit information answer the following questions:

The screenshot shows a form titled "Audit Information" with the following fields and instructions:

- Amount PAID for June 2020 ***: A text input field with a dollar sign icon. Below it, a red instruction reads: "Do NOT enter invoice amount."
- Payment Date**: A text input field. Below it, red instructions read: "Enter payment date if you made a payment for June 2020" and "If multiple payments were made, enter the date of the first payment."
- Payment Detail**: A text area. Below it, instructions read: "Enter details of PAID check numbers (or ACH references) and amounts for June 2020. This information is optional but will speed up the confirmation process. Payment details are displayed to Dan's Contracting Test."

Once information has been entered, select review and save. Complete same steps for all subcontractors. If there were subcontractors that did not receive a payment for the specific audit month, click the Mark Remaining Subcontractors as Zero button to mark remaining subcontractors as 0.

SUBCONTRACTOR INSTRUCTIONS:

The responsibility of the Subcontractor is to confirm payment received for specific audit month.

1. Log in to B2GNow Diversity Management System (B2GNow)
2. On the Dashboard, select Contract Audits.
3. Select the specific audit that needs to be completed.
4. To complete audit, select Confirm Payment Received. There will be two options: correct or incorrect. Select correct if payment was in fact received OR if payment was not received or amount was different select incorrect. Answer all questions and select save to complete.

The screenshot shows a form titled "Compliance Audit Information" with the following fields and options:

- Amount Reported by the prime contractor for November 2021 as PAID to You**: A text field displaying "\$500.00" in red.
- Confirm Reported Amount? ***: Two radio button options:
 - Correct - the amount reported by the prime contractor as PAID to us is correct (\$500.00).
 - Incorrect - the amount reported by the prime contractor as PAID to us is not correct.
- Final Payment? ***: Three radio button options:
 - No - our work on this contract continues.
 - Yes - this is our last payment for this contract.
 - N/A - we have not begun work on this project or we have not been paid yet for our work.
- Is Prime Withholding Retainage? ***: Two radio button options:
 - No
 - Yes

NOTE: Complete one M/WBE report per project.

An email notice will be sent from our organization monthly to notify Prime & Subcontractor users of incomplete audits.



Project Specific Monthly Report

Human Relations Department - City of Kansas City Missouri

Report Date:	Reporting Period:	Project Description:	
Project Name:	Contractor:	Contract Awarded Date:	
City Project Number:	Contractor Address:	City Contract Number:	
Project Address:		City Vendor ID:	
	Contact Person/Phone:	Contractor Report <input type="checkbox"/>	Subcontractor Report <input type="checkbox"/>
E-mail Address:		Final Cumulative Report:	<input type="checkbox"/> Yes <input type="checkbox"/> No

Report the total monthly hours of work performed by all workers on the City Construction Contract. Enter the total hours on all lines and in all columns. Reported workforce hours should be based on payroll records.

JOB CATEGORIES	OVERALL TOTAL (Sum of all Columns, A thru F Male & Female)	A Total Hours White Employees		B Total Hours Black Employees		C Total Hours Hispanic Employees		D Total Hours Asian/Pacific Islander		E Total Hours Native American Employee		F Total Hours Other/Unknown Race Employee		G KCMO Resident Hours
		M	F	M	F	M	F	M	F	M	F	M	F	Total #
		Foreman/Supervisor												
Asbestos Worker Journeyman														
Asbestos Worker Apprentice														
Boilermaker Journeyman														
Boilermaker Apprentice														
Bricklayer Journeyman														
Bricklayer Apprentice														
Carpenter Journeyman														
Carpenter Apprentice														
Cement Mason Journeyman														
Cement Mason Apprentice														
Electrician Journeyman														
Electrician Apprentice														
Elevator Constructor Journeyman														
Elevator Constructor Apprentice														
Glazier Journeyman														
Glazier Apprentice														
Iron Worker Journeyman														
Iron Worker Apprentice														
Laborer Journeyman														
Laborer Apprentice														
Operating Engineer Journeyman														
Operating Engineer Apprentice														
Painter Journeyman														
Painter Apprentice														
Pipe Fitter/Plumber Journeyman														
Pipe Fitter/Plumber Apprentice														
Plasterer Journeyman														
Plasterer Apprentice														
Roofer Journeyman														
Roofer Apprentice														
Sheet Metal Journeyman														
Sheet Metal Apprentice														
Sprinkler Fitter														
Sprinkler Fitter Apprentice														
Truck Driver Journeyman														
Truck Driver Apprentice														
Welder Journeyman														
Welder Apprentice														
Other														
Monthly Total Hours														-
Total % of Monthly Hrs.														

Contractor shall submit report by the 15th of each month.														
Phillip Yelder, Director Human Relations Department										Report Submitted By:				
414 E. 12th Street, 4th Floor					Kansas City, MO 64106									
Phone: 816-513-1836					Email: HRDcontractcompliance@kcmo.org					Date:				

Workforce Monthly Report Forms only apply to Construction Contracts greater than \$300,000.00 with greater than 800 projected labor hours.

Workforce Monthly Report Instructions

(Instructions for online reporting)

Completing a Workforce Audit:

To report your workforce hours:

1. Log into B2GNow Diversity Management System (B2GNow)
2. Click on the red underlined number of 'Incomplete audits' under Workforce Audits
3. Click View for the incomplete audit that needs to be completed.
4. Click Fill in Audit
5. Complete the form including the Payroll Number. Select Add to Audit to report hours worked for specific Craft/Trade.

* required entry

Summary information	
CONTRACTOR	KCMO Test Vendor Sample
PAYROLL START DATE	11/1/2021
PAYROLL END DATE	11/30/2021
PAYROLL NUMBER	<input type="text"/>
SPECIAL STATUS	<input type="checkbox"/> No Work (all fields will be filled with zeros) <input type="checkbox"/> Suspended <input type="checkbox"/> Final

Enter values below as hours worked. There is no need to fill in zeros; all blank fields will be saved as zero.

Craft/Trade List														
Craft/Trade	Caucasian		Black/African American		Hispanic/Latino		Asian		Native American		Other/Unknown Ethnicity		Local Resident	Comments
	Male	Female	Male	Female	Male	Female	Male	Female	Male	Female	Male	Female		
Foreman/Supervisor														Not included in audit Add to audit
Asbestos Worker (Journeyman)														Not included in audit Add to audit

6. Scroll down and select review once hours have been reported.
7. Save and Certify to submit OR Save but Certify Later (to save a draft of your audit response). Audit must be certified for the workforce audit to be submitted for review. If there is an audit where no work was performed, and have 0 hours to report, select the Mark as No Work Audit button on step 4 to report 0 hours for all your employees. Select Certify & Release to Organization to complete. Mark Final for Special Status if the audit being completed is the last month of work, this will notify the system to stop generating monthly audits.

NOTE: If subcontractor has completed Workforce Audit, Prime MUST either accept audit and release to the organization or reject audit back to Subcontractor for correction.

An email notice will be sent from our organization monthly to notify Prime & Subcontractor users of incomplete audits.



Company-Wide Workforce Monthly Report

Human Relations Department - City of Kansas City, Missouri

Report Date:	Reporting Period:	Contract Awarded Date:	
Contractor:		City Vendor ID:	
Contact Person/Phone:	Contractor Address:	Contractor Report <input type="checkbox"/>	Subcontractor Report <input type="checkbox"/>
E-mail Address:	Have you hired any new construction workers this month?	<input type="checkbox"/> Yes <input type="checkbox"/> No	Final Cumulative Report: <input type="checkbox"/> Yes <input type="checkbox"/> No

Report total of all hours of work performed company-wide on all projects in the KCMO Metropolitan Statistical Area (MSA). Enter the total hours on all lines and in all columns. Workforce hours should be based on payroll records.

JOB CATEGORIES	OVERALL TOTAL (Sum of all Columns, A thru F Male & Female)	A Total Hours White Employees		B Total Hours Black Employees		C Total Hours Hispanic Employees		D Total Hours Asian/Pacific Islander		E Total Hours Native American Employee		F Total Hours Other/Unknown Race Employee		G KCMO Resident Hours Total #
		M	F	M	F	M	F	M	F	M	F	M	F	
Foreman/Supervisor														
Asbestos Worker Journeyman														
Asbestos Worker Apprentice														
Boilermaker Journeyman														
Boilermaker Apprentice														
Bricklayer Journeyman														
Bricklayer Apprentice														
Carpenter Journeyman														
Carpenter Apprentice														
Cement Mason Journeyman														
Cement Mason Apprentice														
Electrician Journeyman														
Electrician Apprentice														
Elevator Constructor Journeyman														
Elevator Constructor Apprentice														
Glazier Journeyman														
Glazier Apprentice														
Iron Worker Journeyman														
Iron Worker Apprentice														
Laborer Journeyman														
Laborer Apprentice														
Operating Engineer Journeyman														
Operating Engineer Apprentice														
Painter Journeyman														
Painter Apprentice														
Pipe Fitter/Plumber Journeyman														
Pipe Fitter/Plumber Apprentice														
Plasterer Journeyman														
Plasterer Apprentice														
Roofer Journeyman														
Roofer Apprentice														
Sheet Metal Journeyman														
Sheet Metal Apprentice														
Sprinkler Fitter														
Sprinkler Fitter Apprentice														
Truck Driver Journeyman														
Truck Driver Apprentice														
Welder Journeyman														
Welder Apprentice														
Other														
Total Monthly Hours														
Total % of Hours														

Contractor shall submit report by the 15th of each month.													
Phillip Yelder, Director Human Relations Department 414 E. 12th Street, 4th Floor, Kansas City, MO 64106 Phone: 816-513-1836 Email: HRDcontractcompliance@kcmo.org										Report Submitted By: _____			
										Date: _____			

	Name		Job Title <i>(use drop down menu)</i>	Address	City	State	Zip Code	KCMO Resident	Gender	Ethnicity
	Last	First								
16										
17										
18										
19										
20										
21										
22										
23										
24										
25										
26										
27										
28										
29										
30										
31										
32										
33										
34										
35										
36										
37										
38										
39										
40										
41										
42										
43										
44										
45										
46										
47										
48										
49										



	Name		Job Title <i>(use drop down menu)</i>	Address	City	State	Zip Code	KCMO Resident	Gender	Ethnicity
	Last	First								
50										
51										
52										
53										
54										
55										
56										
57										
58										
59										
60										
61										
62										
63										
64										
65										
66										
67										
68										
69										
70										
71										
72										
73										
74										
75										
76										
77										
78										
79										
80										
81										
82										
83										





Pre Contract Bidder's Certification

Project Number 60800073

Project Title Water Department Emergency Transmission Water Main Repair

STATE OF _____)
) SS
COUNTY OF _____)

Before me, the undersigned authority, personally appeared, who, being by me duly sworn deposed as follows:

I am authorized to make this affidavit on behalf of the named Bidder. I am of sound mind, capable of making this affidavit, and personally acquainted with the facts herein stated:

A. Bidder is current on payment of its Federal and State Income tax withholding and unemployment insurance payments, either in Missouri for companies doing business in Missouri, or in the state in which Bidder has its principal office; and

B. Bidder declares one of the following, regarding all work performed two (2) years immediately preceding the date of the Bid (check one):

Contract by contract listing of all of Bidder's written notices of violations of any Federal or State prevailing wage statute in which prevailing wage penalties were assessed against the Bidder or paid by the Bidder (Complete and attach additional sheets if necessary):

1. _____
2. _____
3. _____

There have been no written notices of violations of any Federal or State prevailing wage statute in which prevailing wage penalties were assessed against the Bidder or paid by the Bidder.

C. Bidder is currently in good standing with the Missouri Secretary of State or Bidder has filed a Registration of Fictitious Name with the Missouri Secretary of State.

(Bidder's Name)

(Date)

Signature of Person Making This Affidavit

In witness whereof, I have hereunto subscribed my name and affixed my official seal this ___ day of _____, 20__.



CONTRACT REQUIRED SUBMISSIONS

Project/Contract Number 60800073/9848

Project/Contract Title/Description Water Department Emergency Transmission
Water Main Repair

These instructions are to assist Contractor in providing all necessary documents to enter into a contract with the City.

MISSOURI SECRETARY OF STATE BUSINESS ENTITY REGISTRATION

- For a corporation, current Certificate of Good Standing from the Missouri Secretary of State ((816) 889-2925 or (816) 889-2926 or a web site print-out, dated no more than ninety (90) days before the date furnished to the City – One Copy.
- For a business that is not a corporation and not doing business in the exact name of the proprietor, a copy from the Secretary of State, ((816) 889-2925 or (816) 889-2926 of the filed Registration of Fictitious Name dated no more than ninety (90) days before the date furnished to the City – One Copy.

EMPLOYEE ELIGIBILITY VERIFICATION AFFIDAVIT [Required if the contract exceeds \$5,000.00]

- 00515.01 Employee Eligibility Verification Affidavit – One Executed Affidavit
- First and last pages of the E-Verify Program Memorandum of Understanding that your company has received from the U.S. Department of Homeland Security verifying enrollment in the program. For assistance, contact E-Verify Operations at 888-464-4218 – One Copy.

SUBCONTRACTORS LISTING [Applicable form provided]

- Non-Construction Subcontractors List – One Copy
- 01290.09 Subcontractors & Major Material Suppliers List – One Copy

PAYMENT BONDS (If applicable)

- Each copy of the Payment bond must be signed and properly dated by the following, as applicable:

Corporation - A corporate officer authorized to sign on behalf of the corporation and the signature must be attested by a witness to the signature; OR

Limited Liability Company - A member of the limited liability company authorized to sign on behalf of the company and a witness to the signature must attest the signature; OR

Partnership - A partner authorized to sign on behalf of the partnership and the signature must be attested by a witness to the signature; OR

Sole Proprietor - By the proprietor and the signature must be attested by a witness to the signature; OR

Joint Venture - The parties to the Joint Venture authorized to sign on behalf of each party to the Joint Venture, or a person authorized by each party to the Joint Venture to sign on behalf of all parties to the Joint Venture; AND

Surety - A person authorized by the Surety to sign on behalf of the Surety. A power of attorney issued by the Surety Company authorizing its representative to sign the Agreement must be attached to the Agreement and each copy.

PERFORMANCE AND MAINTENANCE BOND (If applicable)

- As applicable, each copy of the Performance and Maintenance bond must be signed and properly dated by:

Corporation - A corporate officer authorized to sign on behalf of the corporation and the signature must be attested by a witness to the signature; OR

Limited Liability Company - A member of the limited liability company authorized to sign on behalf of the company and a witness to the signature must attest the signature; OR

Partnership - A partner authorized to sign on behalf of the partnership and the signature must be attested by a witness to the signature; OR

Sole Proprietor - By the proprietor and the signature must be attested by a witness to the signature; OR

Joint Venture - The parties to the Joint Venture authorized to sign on behalf of each party to the Joint Venture, or a person authorized by each party to the Joint Venture to sign on behalf of all parties to the Joint Venture; AND

Surety - A person authorized by the Surety to sign on behalf of the Surety. A power of attorney issued by the Surety Company authorizing its representative to sign the Agreement must be attached to the Agreement and each copy.

CERTIFICATES OF INSURANCE [Sample form provided] - If you have any questions regarding requirements for insurance certificates, please contact the City's Risk Management Office, 816 513-1299.

- Provide a certificate of insurance for all insurance that may be required in the contract such as:
 - Commercial General Liability
 - Workers' Compensation and Employers' Liability
 - Commercial Automobile Liability
 - Railroad Protective Liability
 - Environmental Liability
 - Asbestos Liability
 - Longshoremen's Insurance
 - Property Insurance
- List the NAIC Number (National Association of Insurance Commissioners) or A.M. Best Number for each Insurer listed on the Certificate of Insurance.
- Certificate "Kansas City, Missouri" must named as an Additional Insured.
- Check the insurance requirements of the Contract. If Contract Documents require that other entities be included as additional insureds, each entity shall be listed on the certificate(s).
- Description of Operations must include Project/Contract Number and Project/Contract Title/Description as contained in the Contract Documents. The Certificate Holder and address block shall be completed as follows:
 - Kansas City, Missouri
 - [Name of applicable City Department]**
 - [Name of Contract Administrator, Buyer, or Project Manager]**
 - [Department Address]**
 - Kansas City, Missouri **[Zip Code]**
- If your insurance agent prepares an ACORD form, the automobile insurance must be "any auto" or better for acceptance by the City.

AFFIRMATIVE ACTION REQUIREMENTS

- Proposed Affirmative Action Program or a copy of a Certificate of Affirmative Action Compliance – One copy.

PRE-CONTRACT BIDDER'S CERTIFICATION (Prevailing Wage Contracts; Form provided)

- Submit form 00490 - Bidder's Pre-Contract Certification (provided).

HEALTH AND SAFETY PLAN (If applicable)

- Bidder's Health and Safety Plan – One copy or one CD Rom.

EMPLOYEE ELIGIBILITY VERIFICATION AFFIDAVIT

(Required for any contract with the City of Kansas City, Missouri in excess of \$5,000.00)

STATE OF _____)
) ss
COUNTY OF _____)

On this _____ day of _____, 20____, before me appeared _____, personally known by me or otherwise proven to be the person whose name is subscribed on this affidavit and who, being duly sworn, stated as follows:

I am of sound mind, capable of making this affidavit, and personally swear or affirm that the statements made herein are truthful to the best of my knowledge. I am the _____ (title) of _____ (business entity) and I am duly authorized, directed or empowered to act with full authority on behalf of the business entity in making this affidavit.

I hereby swear or affirm that the business entity does not knowingly employ any person in connection with the contracted services who does not have the legal right or authorization under federal law to work in the United States as defined in 8 U.S.C. § 1324a(h)(3).

I hereby additionally swear or affirm that the business entity is enrolled in an electronic verification of work program operated by the United States Department of Homeland Security (E-Verify) or an equivalent federal work authorization program operated by the United States Department of Homeland Security to verify information of newly hired employees, under the Immigration Reform and Control Act of 1986, and that the business entity will participate in said program with respect to any person hired by the business entity to perform any work in connection with the contracted services. I have attached hereto documentation sufficient to establish the business entity’s enrollment and participation in the required electronic verification of work program.

I am aware and recognize that unless certain contractual requirements are satisfied and affidavits obtained as provided in Section 285.530, RSMo, the business entity may face liability for violations committed by its subcontractors, notwithstanding the fact that the business entity may itself be compliant.

I acknowledge that I am signing this affidavit as the free act and deed of the business entity and that I am not doing so under duress.

Affiant's signature

Subscribed and sworn to before me this _____ day of _____, 20____.

Notary Public

My Commission expires:



Missouri Department of Revenue
Project Exemption Certificate

This form is to be completed and given to your contractor.

Exempt Entity and Project Information	Name of Exempt Entity Issuing the Certificate		Missouri Tax Exemption Number			
	Address		City		State	ZIP Code
	E-mail Address					
	Project Number	Project Begin Date (MM/DD/YYYY) ____/____/____		Estimated Project End Date (MM/DD/YYYY) ____/____/____		
	Description of Project					
	Project Location			Certificate Expiration Date (MM/DD/YYYY) ____/____/____		
	Provide a signed copy of this certificate, along with a copy of the exempt entity's Missouri Sales and Use Tax Exemption Letter to each contractor or subcontractor who will be purchasing tangible personal property for use in this project. It is the responsibility of the exempt entity to ensure the validity of the information on the certificate. The exempt entity must issue a new certificate if any of the information changes.					
Signature of Authorized Exempt Entity		Printed Name of Authorized Exempt Entity		Date (MM/DD/YYYY) ____/____/____		

Contractor	The Missouri exempt entity named above hereby authorizes the purchase, without sales tax, of tangible personal property to be incorporated or consumed in the construction project identified herein and no other, pursuant to Section 144.062, RSMo . Under penalties of perjury, I declare that the above information and any attached supplement is true, complete, and correct.					
	Name of Purchasing Contractor		Signature of Contractor		Date (MM/DD/YYYY) ____/____/____	
	Address		City		State	ZIP Code

Subcontractor	Contractors - Present this to your supplier in order to purchase the necessary materials tax exempt. Complete the Subcontractor portion if extending the certificate to your subcontractor. The contractor must sign the form in the space provided below.					
	Name of Purchasing Subcontractor					
	Address		City		State	ZIP Code
	Signature of Contractor		Contractor's Printed Name		Date (MM/DD/YYYY) ____/____/____	

Form 5060 (Revised 08-2015)

Taxation Division
P.O Box 358
Jefferson City, MO 65105-0358

Phone: (573) 751-2836
Fax: (573) 522-1271
E-mail: salestaxexemptions@dor.mo.gov

Visit <http://dor.mo.gov/business/sales/sales-use-exemptions.php> for additional information.



State of Missouri

EXEMPTION FROM MISSOURI SALES AND USE TAX ON PURCHASES

Issued to:

CITY OF KANSAS CITY
414 E 12TH ST 3RD FLOOR
KANSAS CITY MO 64106

Missouri Tax ID
Number: 12490466

Effective Date:
07/11/2002

Your application for sales/use tax exempt status has been approved pursuant to Section 144.030.1, RSMo. This letter is issued as documentation of your exempt status.

Purchases by your Agency are not subject to sales or use tax if within the conduct of your Agency's exempt functions and activities. When purchasing with this exemption, furnish all sellers or vendors a copy of this letter. This exemption may not be used by individuals making personal purchases.

A contractor may purchase and pay for construction materials exempt from sales tax when fulfilling a contract with your Agency only if your Agency issues a project exemption certificate and the contractor makes purchases in compliance with the provisions of Section 144.062, RSMo.

Sales by your Agency are subject to all applicable state and local sales taxes. If you engage in the business of selling tangible personal property or taxable services at retail, you must obtain a Missouri Retail Sales Tax License and collect and remit sales tax.

This is a continuing exemption subject to legislative changes and review by the Director of Revenue. If your Agency ceases to qualify as an exempt entity, this exemption will cease to be valid. This exemption is not assignable or transferable. It is an exemption from sales and use taxes only and is not an exemption from real or personal property tax.

Any alteration to this exemption letter renders it invalid.

If you have any questions regarding the use of this letter, please contact the Division of Taxation and Collection, P.O. Box 3300, Jefferson City, MO 65105-3300, phone 573-751-2836.



PERFORMANCE AND MAINTENANCE BOND

Project Number 60800073

Project Title Water Department Emergency Transmission Water Main Repair

KNOW ALL MEN BY THESE PRESENTS: That _____, as PRINCIPAL (CONTRACTOR), and _____, (SURETY), licensed to do business as such in the State of Missouri, hereby bind themselves and their respective heirs, executors, administrators, successors, and assigns unto Kansas City, Missouri, a constitutionally chartered municipal corporation, (OWNER), as obligee, in the penal sum of _____ Dollars (\$ _____) for the payment whereof CONTRACTOR and SURETY bind themselves, their heirs, executors, administrators, successors and assigns, jointly and severally, firmly by these presents.

WHEREAS,

CONTRACTOR has entered into a Contract with OWNER for _____ which Contract, including any present or future amendment thereto, is incorporated herein by reference and is hereinafter referred to as the Contract.

NOW, THEREFORE, THE CONDITION OF THIS OBLIGATION is such that, if CONTRACTOR shall promptly and faithfully perform said Contract including all duly authorized changes thereto, and including any maintenance requirements contained therein, according to all the terms thereof, including those under which CONTRACTOR agrees to pay legally required wage rates including the prevailing hourly rate of wages in the locality, as determined by the Department of Labor and Industrial Relations or by final judicial determination, for each craft or type of workman required to execute the Contract and, further, shall defend, indemnify, and hold harmless OWNER from all damages, including but not limited to, liquidated damages, loss and expense occasioned by any failure whatsoever of said CONTRACTOR and SURETY to fully comply with and carry out each and every requirement of the Contract, then this obligation shall be void; otherwise, it shall remain in full force and effect.

WAIVER. That SURETY, for value received, hereby expressly agrees that no change, extension of time, alteration or addition to the terms of the Contract or to the Work to be performed thereunder, shall in any way affect the obligations of this Bond; and it does hereby waive notice of any such change, extension of time, or alteration or addition to the terms of the Contract or the Work to be performed thereunder.

IN WITNESS WHEREOF, the above parties have executed this instrument the ____ day of _____, 20__.

CONTRACTOR

Name, address and facsimile number of Contractor

I hereby certify that I have authority to execute this document on behalf of Contractor.

By: _____
Title: _____

(Attach corporate seal if applicable)

SURETY

Name, address and facsimile number of Surety:

I hereby certify that (1) I have authority to execute this document on behalf of Surety; (2) Surety has an A.M. Best rating of A-, V, or better; (3) Surety is named in the current list of "Companies Holding Certificates of Authority as Acceptable Reinsuring Companies: as published in Circular 570 (most current revision) by the Financial Management Service, Surety Bond Branch, U.S. Department of the Treasury; and (4) Surety is duly licensed to issue bonds in the State of Missouri and in the jurisdiction in which the Project is located.

By: _____
Title: _____
Date: _____

(Attach seal and Power of Attorney)



PAYMENT BOND

Project Number 60800073

Project Title Water Department Emergency Transmission Water Main Repair

KNOW ALL MEN BY THESE PRESENTS: That _____, as PRINCIPAL (CONTRACTOR), and _____, (SURETY), licensed to do business as such in the State of Missouri, hereby bind themselves and their respective heirs, executors, administrators, successors, and assigns unto Kansas City, Missouri, a constitutionally chartered municipal corporation, (OWNER), as obligee, in the penal sum of _____ Dollars (\$_____) for the payment whereof CONTRACTOR and SURETY bind themselves, their heirs, executors, administrators, successors and assigns, jointly and severally, firmly by these presents.

WHEREAS,

CONTRACTOR has entered into a contract with OWNER for _____, which Contract, including any present or future amendment thereto, is incorporated herein by reference and is hereinafter referred to as the Contract.

NOW, THEREFORE, THE CONDITION OF THIS OBLIGATION is such that, if in connection with the Contract, including all duly authorized modifications thereto, prompt payment shall be made to all laborers, subcontractors, teamsters, truck drivers, owners or other suppliers or for equipment employed on the job, and other claimants, for all labor performed in such work whether done for CONTRACTOR, a subcontractor, SURETY, a completion contractor or otherwise (at the full wage rates required by any law of the United States or of the State of Missouri, where applicable), for services furnished and consumed, for repairs on machinery, for equipment, tools, materials, lubricants, oil, gasoline, water, gas, power, light, heat, oil, telephone service, grain, hay, feed, coal, coke, groceries and foodstuffs, either consumed, rented, used or reasonably required for use in connection with the construction of the work or in the performance of the Contract and all insurance premiums, both for compensation and for all other kinds of insurance on the work, for sales taxes and for royalties in connection with, or incidental to, the completion of the Contract, in all instances whether the claim be directly against CONTRACTOR, against SURETY or its completion contractor, through a subcontractor or otherwise, and, further, if CONTRACTOR shall defend, indemnify and hold harmless OWNER from all such claims, demands or suits by any such person or entity, then this obligation shall be void; otherwise, it shall remain in full force and effect.

Any conditions legally required to be included in a Payment Bond on this Contract, including but not limited to those set out in §107.170 RSMo. are included herein by reference.

SURETY agrees that, in the event that CONTRACTOR fails to make payment of the obligations covered by this Bond, it will do so and, further, that within forty-five (45) days of receiving, at the address given below, a claim hereunder stating the amount claimed and the basis for the claim in reasonable detail, it (a) will send an answer to the claimant, with a copy to OWNER stating the amounts that are undisputed and the basis for challenging any amounts that are disputed, and (b) will pay any amounts that are undisputed. The amount of this Bond shall be reduced by and to the extent of any payment or payments made in good faith hereunder.

While this Bond is in force, it may be sued on at the instance of any party to whom any such payment is due, in the name of OWNER to the use for such party. OWNER shall not be liable for the payment of any costs or expenses of any such suit.

No suit shall be commenced or pursued hereunder other than in a state court of competent jurisdiction in Jackson, Clay or Platte County, Missouri, or in the United States District Court for the Western District of Missouri.

WAIVER. That SURETY, for value received, hereby expressly agrees that no change, extension of time, alteration or addition to the terms of the Contract or to the Work to be performed thereunder, shall in any way affect the obligations of this Bond; and it does hereby waive notice of any such change, extension of time, or alteration or addition to the terms of the Contract or the Work to be performed thereunder.

IN WITNESS WHEREOF, the above parties have executed this instrument the _____ day of _____, 20____.

CONTRACTOR

Name, address and facsimile number of Contractor

I hereby certify that I have authority to execute this document on behalf of Contractor.

By: _____
Title: _____

(Attach corporate seal if applicable)

SURETY

Name, address and facsimile number of Surety:

I hereby certify that (1) I have authority to execute this document on behalf of Surety; (2) Surety has an A.M. Best rating of A- or better; (3) Surety is named in the current list of "Companies Holding Certificates of Authority as Acceptable Sureties on Federal Bonds and as Acceptable Reinsuring Companies" as published in Circular 570 (most current revision) by the Financial Management Service, Surety Bond Branch, U.S. Department of the Treasury; and(4) Surety is duly licensed to issue bonds in the State of Missouri and in the jurisdiction in which the Project is located.

By: _____
Title: _____
Date: _____

(Attach seal and Power of Attorney)



PERFORMANCE BOND

Project Number 60800073

Project Title Water Department Emergency Transmission Water Main Repair

KNOW ALL MEN BY THESE PRESENTS: That _____, as PRINCIPAL (CONTRACTOR), and _____, (SURETY), licensed to do business as such in the State of Missouri, hereby bind themselves and their respective heirs, executors, administrators, successors, and assigns unto Kansas City, Missouri, a constitutionally chartered municipal corporation, (OWNER), as obligee, in the penal sum of _____ Dollars (\$ _____) for the payment whereof CONTRACTOR and SURETY bind themselves, their heirs, executors, administrators, successors and assigns, jointly and severally, firmly by these presents.

WHEREAS,

CONTRACTOR has entered into a Contract with OWNER for _____ which Contract, including any present or future amendment thereto, is incorporated herein by reference and is hereinafter referred to as the Contract.

NOW, THEREFORE, THE CONDITION OF THIS OBLIGATION is such that, if CONTRACTOR shall promptly and faithfully perform said Contract including all duly authorized changes thereto, according to all the terms thereof, including those under which CONTRACTOR agrees to pay legally required wage rates including the prevailing hourly rate of wages in the locality, as determined by the Department of Labor and Industrial Relations or by final judicial determination, for each craft or type of workman required to execute the Contract and, further, shall defend, indemnify, and hold harmless OWNER from all damages, including but not limited to liquidated damages, loss and expense occasioned by any failure whatsoever of said CONTRACTOR and SURETY to fully comply with and carry out each and every requirement of the Contract, then this obligation shall be void; otherwise, it shall remain in full force and effect.

WAIVER. That SURETY, for value received, hereby expressly agrees that no change, extension of time, alteration or addition to the terms of the Contract or to the Work to be performed thereunder, shall in any way affect the obligations of this Bond; and it does hereby waive notice of any such change, extension of time, or alteration or addition to the terms of the Contract or the Work to be performed thereunder.

IN WITNESS WHEREOF, the above parties have executed this instrument the ____ day of _____, 20_____.

CONTRACTOR

Name, address and facsimile number of Contractor

I hereby certify that I have authority to execute this document on behalf of Contractor.

By: _____
Title: _____

(Attach corporate seal if applicable)

SURETY

Name, address and facsimile number of Surety:

I hereby certify that (1) I have authority to execute this document on behalf of Surety; (2) Surety has an A.M. Best rating of A- or better; (3) Surety is named in the current list of "Companies Holding Certificates of Authority as Acceptable Reinsuring Companies: as published in Circular 570 (most current revision) by the Financial Management Service, Surety Bond Branch, U.S. Department of the Treasury; and (4) Surety is duly licensed to issue bonds in the State of Missouri and in the jurisdiction in which the Project is located.

By: _____
Title: _____
Date: _____

(Attach seal and Power of Attorney)



CERTIFICATE OF LIABILITY INSURANCE

DATE (MM/DD/YYYY)

THIS CERTIFICATE IS ISSUED AS A MATTER OF INFORMATION ONLY AND CONFERS NO RIGHTS UPON THE CERTIFICATE HOLDER. THIS CERTIFICATE DOES NOT AFFIRMATIVELY OR NEGATIVELY AMEND, EXTEND OR ALTER THE COVERAGE AFFORDED BY THE POLICIES BELOW. THIS CERTIFICATE OF INSURANCE DOES NOT CONSTITUTE A CONTRACT BETWEEN THE ISSUING INSURER(S), AUTHORIZED REPRESENTATIVE OR PRODUCER, AND THE CERTIFICATE HOLDER.

IMPORTANT: If the certificate holder is an ADDITIONAL INSURED, the policy(ies) must be endorsed. If SUBROGATION IS WAIVED, subject to the terms and conditions of the policy, certain policies may require an endorsement. A statement on this certificate does not confer rights to the certificate holder in lieu of such endorsement(s).

PRODUCER AGENT NAME AND ADDRESS	CONTACT NAME:	
	PHONE (A/C, No, Ext):	FAX (A/C, No):
INSURED CONTRACTOR NAME AND ADDRESS	E-MAIL ADDRESS:	
	INSURER(S) AFFORDING COVERAGE	
	INSURER A :	ABC INSURANCE COMPANY
	INSURER B :	
	INSURER C :	
	INSURER D :	
	INSURER E :	
	INSURER F :	

COVERAGES **CERTIFICATE NUMBER:** **REVISION NUMBER:**

THIS IS TO CERTIFY THAT THE POLICIES OF INSURANCE LISTED BELOW HAVE BEEN ISSUED TO THE INSURED NAMED ABOVE FOR THE POLICY PERIOD INDICATED. NOTWITHSTANDING ANY REQUIREMENT, TERM OR CONDITION OF ANY CONTRACT OR OTHER DOCUMENT WITH RESPECT TO WHICH THIS CERTIFICATE MAY BE ISSUED OR MAY PERTAIN, THE INSURANCE AFFORDED BY THE POLICIES DESCRIBED HEREIN IS SUBJECT TO ALL THE TERMS, EXCLUSIONS AND CONDITIONS OF SUCH POLICIES. LIMITS SHOWN MAY HAVE BEEN REDUCED BY PAID CLAIMS.

INSR LTR	TYPE OF INSURANCE	ADDL INSR	SUBR WVD	POLICY NUMBER	POLICY EFF (MM/DD/YYYY)	POLICY EXP (MM/DD/YYYY)	LIMITS
A	GENERAL LIABILITY <input checked="" type="checkbox"/> COMMERCIAL GENERAL LIABILITY <input type="checkbox"/> CLAIMS-MADE <input checked="" type="checkbox"/> OCCUR GEN'L AGGREGATE LIMIT APPLIES PER: <input type="checkbox"/> POLICY <input checked="" type="checkbox"/> PROJECT <input type="checkbox"/> LOC	Y	Y	POLICY NUMBER	1/1/2011	Current	EACH OCCURRENCE \$ 1,000,000 DAMAGE TO RENTED PREMISES (Ea occurrence) \$ 50,000 MED EXP (Any one person) \$ 10,000 PERSONAL & ADV INJURY \$ 1,000,000 GENERAL AGGREGATE \$ 2,000,000 PRODUCTS - COMP/OP AGG \$ 2,000,000 \$
A	AUTOMOBILE LIABILITY <input checked="" type="checkbox"/> ANY AUTO ALL OWNED AUTOS <input checked="" type="checkbox"/> HIRED AUTOS <input type="checkbox"/> SCHEDULED AUTOS NON-OWNED AUTOS	Y	Y	POLICY NUMBER	1/1/2011	Current	COMBINED SINGLE LIMIT (Ea accident) \$ 1,000,000 BODILY INJURY (Per person) \$ BODILY INJURY (Per accident) \$ PROPERTY DAMAGE (Per accident) \$ \$
A	<input checked="" type="checkbox"/> UMBRELLA LIAB <input checked="" type="checkbox"/> EXCESS LIAB <input checked="" type="checkbox"/> RETENTION \$ 10,000 <input type="checkbox"/> OCCUR <input type="checkbox"/> CLAIMS-MADE	Y	Y	POLICY NUMBER	1/1/2011	Current	EACH OCCURRENCE \$ 2,000,000 AGGREGATE \$ 2,000,000 \$
A	WORKERS COMPENSATION AND EMPLOYERS' LIABILITY ANY PROPRIETOR/PARTNER/EXECUTIVE OFFICER/MEMBER EXCLUDED? (Mandatory in NH) If yes, describe under DESCRIPTION OF OPERATIONS below	Y/N	N/A	Y	POLICY NUMBER	1/1/2011	<input checked="" type="checkbox"/> WC STATUTORY LIMITS <input type="checkbox"/> OTHER E.L. EACH ACCIDENT \$ 1,000,000 E.L. DISEASE - EA EMPLOYEE \$ 1,000,000 E.L. DISEASE - POLICY LIMIT \$ 1,000,000
A	Leased/Rented/Equip. Owned Equipment Builders Risk/Installation Floater	N/A	Y	POLICY NUMBER	1/1/2011	Current	Limit; Deductible Limit; Deductible Limit; Deductible

DESCRIPTION OF OPERATIONS / LOCATIONS / VEHICLES (Attach ACORD 101, Additional Remarks Schedule, if more space is required)

Project No. _____ [Title]. Certholder (City) and _____ (Design Professional) and any other entities named in 00800 SCs are named as primary, noncontributing Additional Insureds including products and completed operations, excluding workers compensation, employers liability and professional liability. Waiver of subrogation applies as allowed by law. [The policies required above shall contain no exclusions for work expressly within the subcontractors scope of work.]

CERTIFICATE HOLDER **CANCELLATION**

City of Kansas City, Missouri _____ [Department] _____ [Address] Kansas City, MO _____ [Zip]	SHOULD ANY OF THE ABOVE DESCRIBED POLICIES BE CANCELLED BEFORE THE EXPIRATION DATE THEREOF, NOTICE WILL BE DELIVERED IN ACCORDANCE WITH THE POLICY PROVISIONS. AUTHORIZED REPRESENTATIVE
---	---

FORM RD-C1

(12/20)

City of Kansas City, Missouri - Revenue Division

AUTHORIZATION TO RELEASE A REVENUE CLEARANCE LETTER

Phone: (816) 513-1120
Fax: (816) 513-1264



I authorize the City of Kansas City, Missouri, Finance Department, Revenue Division, to release a Revenue Clearance Letter for:

Name of taxpayer: _____ FEIN or SSN: _____
(PRINT)
Address: _____

Check this box and complete this section to send the Clearance Letter to a contractor.

I authorize the City to provide a copy of the Taxpayer's Revenue Clearance Letter to the following:

NAME (PRINT)	BUSINESS NAME	TITLE
ADDRESS	CITY, STATE, ZIP CODE	
PHONE NUMBER	FAX NUMBER	EMAIL ADDRESS

I authorize the City to provide the Taxpayer's Revenue Clearance Letter to all City Departments to certify that the Taxpayer is in compliance with the tax ordinances administered by the Commissioner of Revenue.

Please send my first Revenue Clearance Letter to: _____
(Print Name of City Department / Contact Person / Email / Fax Number)

This authorization shall expire one (1) year from the date on the bottom of this form.

The City, Commissioner of Revenue and the Revenue Division personnel (hereinafter "the City"), are hereby held harmless from any and all liability relating to unauthorized disclosure of confidential tax information resulting from release of information under all applicable confidentiality laws including federal, state, or local, including any damages sustained by wrongful transmission of confidential tax information to any other person.

UNDER PENALTIES OF PERJURY, I DECLARE THAT I HAVE EXAMINED THIS AUTHORIZATION, AND TO THE BEST OF MY KNOWLEDGE AND BELIEF, IT IS TRUE, CORRECT AND COMPLETE.

I hereby certify that I am the Taxpayer named herein or that I have the authority to execute this authorization on behalf of the Taxpayer and hold harmless agreement.

NAME (PRINT)	TITLE (IF APPLICABLE)	
SIGNATURE	PHONE NUMBER	DATE

A FACSIMILE OF THIS DOCUMENT SHALL CONSTITUTE AN ORIGINAL

Email completed form to business.license@kcmo.org or mail to:

City of Kansas City, Missouri, Business License Office, City Hall, 1st floor, 414 E. 12th St.,
Kansas City, MO 64106

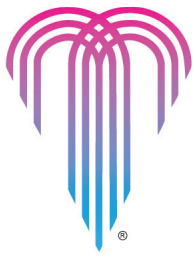

KANSAS CITY
MISSOURI

Finance Department

Revenue Division

414 E 12th St. 1st Floor
Kansas City, MO 64106-2786

**DO NOT MAIL
atL003**

Phone: (816) 513-1120

Fax: (816) 513-1264

Email: revenue@kcmo.org

Website: kcmo.gov/tax

Letter Id: L0000143555

Date: 07-Feb-2024

Taxpayer Id: 0000161779

EXAMPLE TAXPAYER
414 E 12TH ST
KANSAS CITY MO 64106-2702



TAX CLEARANCE STATUS: APPROVED

As of this date, this notice is to inform you that EXAMPLE TAXPAYER is current with all taxes and license fees with the City of Kansas City, Mo., Finance Department/ Revenue Division.

Please note this could change if we perform a full review of your accounts in the future. We will let you know if we need to review your accounts. You will need to pay any amounts that are found due at that time.

Eric Davison
Commissioner of Revenue

Visit kcmo.gov/quicktax to view the status of your account and for online filing.





GENERAL CONDITIONS TABLE OF CONTENTS

ARTICLE 1 DEFINITIONS AND TERMINOLOGY

- 1.01 Defined Terms
- 1.02 Terminology

ARTICLE 2 PRELIMINARY MATTERS

- 2.01 Delivery of Bonds
- 2.02 Evidence of Insurance
- 2.03 Copies of Documents
- 2.04 Commencement of Contract Times; Notice to Proceed
- 2.05 Starting the Work
- 2.06 Before Starting Construction
- 2.07 Initially Acceptable Schedules

ARTICLE 3 CONTRACT DOCUMENTS: INTENT, AMENDING, REUSE

- 3.01 Intent
- 3.02 Reference to Standards and Specifications of Technical Societies
- 3.03 Reporting and Resolving Discrepancies
- 3.04 Amending and Supplementing Contract Documents
- 3.05 Reuse of Documents

ARTICLE 4 AVAILABILITY OF LANDS; SUBSURFACE AND PHYSICAL CONDITIONS; REFERENCE POINTS

- 4.01 Availability of Lands
- 4.02 Subsurface and Physical Conditions
- 4.03 Differing Subsurface or Physical Conditions
- 4.04. Physical Conditions - Underground Facilities
- 4.05 Reference Points
- 4.06 Asbestos, Lead-Based Paint, PCBs, Petroleum, Hazardous Waste or Radioactive Material

ARTICLE 5 BONDS AND INSURANCE

- 5.01 Performance, Payment and Other Bonds
- 5.02 Licensed Sureties and Insurers
- 5.03 Certificates of Insurance
- 5.04 CONTRACTOR's Liability Insurance
- 5.05 CITY's Liability Insurance
- 5.06 Property Insurance
- 5.07 Waiver of Rights
- 5.08 Receipt and Application of Insurance Proceeds
- 5.09 Partial Utilization - Property Insurance

ARTICLE 6 CONTRACTOR'S RESPONSIBILITIES

- 6.01 Indemnification

- 6.02 Supervision and Superintendence
- 6.03 Services, Working Hours, Labor, Materials and Equipment
- 6.04 Progress Schedule
- 6.05 Recovery Schedules
- 6.06 Substitutes and "Or-Equal" Items
- 6.07 Concerning Subcontractors, Suppliers and Others
- 6.08 Patent Fees and Royalties
- 6.09 Permits
- 6.10 Laws or Regulations
- 6.11 Taxes
- 6.12 Use of Site and Other Areas
- 6.13 Record Documents
- 6.14 Safety and Protection
- 6.15 Safety Representative
- 6.16 Hazard Communication Programs
- 6.17 Emergencies
- 6.18 Shop Drawings and Samples
- 6.19 Continuing the Work
- 6.20 CONTRACTOR's General Warranty and Guarantee

ARTICLE 7 OTHER WORK

- 7.01 Related Work at Site
- 7.02 Coordination

ARTICLE 8 CITY's RESPONSIBILITIES

- 8.01 Communications to CONTRACTOR
- 8.02 Replacement of DESIGN PROFESSIONAL
- 8.03 Furnish Data and Prompt Payment
- 8.04 Lands and Easements; Reports and Tests
- 8.05 Insurance
- 8.06 Change Orders
- 8.07 Inspections, Tests and Approvals
- 8.08 Limitations on CITY's Responsibilities
- 8.09 Undisclosed Hazardous Environmental Condition
- 8.10 Evidence of Financial Arrangements
- 8.11 CITY's Representative
- 8.12 Visits to Site

ARTICLE 9 DESIGN PROFESSIONAL's STATUS DURING CONSTRUCTION

- 9.01 General Scope of DESIGN PROFESSIONAL's Duties
- 9.02 Resident Project Representative
- 9.03 Clarifications and Interpretations
- 9.04 Rejecting Defective Work
- 9.05 Shop Drawings, Change Orders and Payments
- 9.06 Determinations for Unit Prices
- 9.07 Decisions on Requirements of Contract Documents and Acceptability of Work
- 9.08 Limitations on DESIGN PROFESSIONAL's Authority and Responsibilities

ARTICLE 10 CHANGES IN THE WORK

- 10.01 Authorized Changes in the Work
- 10.02 Unauthorized Changes in the Work
- 10.03 Execution of Change Orders
- 10.04 Notification to Surety

ARTICLE 11 CHANGE OF CONTRACT PRICE

- 11.01 Change of Contract Price
- 11.02 Cost of the Work
- 11.03 Cash Allowances
- 11.04 Unit Price Work
- 11.05 Dispute Resolution

ARTICLE 12 CONTRACT TIMES

- 12.01 Time of the Essence
- 12.02 Change of Contract Times
- 12.03 Proof Required To Justify An Extension of Time For Excusable and Compensable Delays
- 12.04 Delays Within CONTRACTOR's Control
- 12.05 Delays Beyond the CITY's and CONTRACTOR's Control
- 12.06 Delay Damages
- 12.07 Dispute Resolution

ARTICLE 13 TESTS AND INSPECTIONS; CORRECTION, REMOVAL OR ACCEPTANCE OF DEFECTIVE WORK

- 13.01 Access to Work
- 13.02 Tests and Inspections
- 13.03 Notice of Defects
- 13.04 Uncovering Work
- 13.05 CITY May Stop the Work
- 13.06 Correction or Removal of Defective Work
- 13.07 Correction Period
- 13.08 Acceptance of Defective Work
- 13.09 CITY May Correct Defective Work

ARTICLE 14 PAYMENTS TO CONTRACTOR AND COMPLETION

- 14.01 Schedule of Values
- 14.02 Application for Progress Payments
- 14.03 Contractor's Warranty of Title
- 14.04 Substantial Completion
- 14.05 Partial Utilization
- 14.06 Final Inspection
- 14.07 Final Payment
- 14.08 Final Completion Delayed
- 14.09 Waiver of Claims
- 14.10 Completion of Work by City

ARTICLE 15 SUSPENSION OF WORK AND TERMINATION

- 15.01 CITY May Suspend Work
- 15.02 CITY May Terminate for Default
- 15.03 CITY May Terminate for Convenience

ARTICLE 16 CLAIMS AND DISPUTES

- 16.01 Definition
- 16.02 Written Notice and Burden of Proof
- 16.03 Time Limits on Claims
- 16.04 Continuing Contract Performance
- 16.05 Injury or Damage to Person or Property
- 16.06 Initial Resolution of Claims and Disputes

16.07 Final Resolution of Claims and Disputes

ARTICLE 17 MISCELLANEOUS

17.01 Giving Notice

17.02 Computation of Times

17.03 Cumulative Remedies

17.04 Survival of Obligations

17.05 Controlling Law

ARTICLE 1 DEFINITIONS AND TERMINOLOGY

1.01 Defined Terms

A. Wherever used in these General Conditions or in the other Contract Documents, the following terms have the meanings indicated which are applicable to both the singular and plural thereof:

1. Addenda - Written or graphic instruments issued prior to the opening of Bids that clarify, correct or change the Bidding Requirements or the Contract Documents.

2. Agreement—The written Contract between CITY and CONTRACTOR governing the Work to be performed; other Contract Documents are attached to the Agreement and made a part thereof as provided therein.

3. Application for Payment—The form accepted by CITY's Representative which is to be used by CONTRACTOR in requesting progress or final payments and which is to be accompanied by such supporting documentation as is required by the Contract Documents.

4. Asbestos - Any material that contains more than one percent (1%) Asbestos and is friable or is releasing Asbestos fibers into the air above current action levels established by the United States Occupational Safety and Health Administration.

5. Bid- The offer or proposal of the Bidder submitted on the Bid Form/Contract setting forth the prices for the Work to be performed. A Bidder's Bid becomes a Contract with CITY if the CITY executes the Bid Form/Contract submitted by Bidder. If the CITY executes the Bid Form/Contract submitted by Bidder, the term "Bidder" shall mean CONTRACTOR.

6. Bidder- One who submits a Bid directly to CITY, as distinct from a sub-bidder who submits a bid to a Bidder. If the CITY executes the Bid Form/Contract submitted by Bidder, the term "Bidder" shall mean CONTRACTOR in both the Bidding Documents and Contract Documents unless the context clearly indicates otherwise.

7. Bidding Documents- The advertisement or Invitation to Bid, Instructions to Bidders, the Bid Form/Contract, and the proposed Contract Documents (including all Addenda issued prior to receipt of Bids).

8. Bidding Requirements- The advertisement or invitation to bid, Instructions to Bidders, Bid security, and the Bid Form/Contract with any supplements.

9. Bonds- Payment Bond and Performance and Maintenance Bond and other instruments of security.

10. Calendar Day- Any day shown on the calendar, including Saturdays, Sundays, and holidays.

11. Change Order- A written document issued by CITY that authorizes an addition, deletion or revision in the Work, or an adjustment in the Contract Price or the Contract Times, issued on or after the Effective Date of the Contract.

12. CITY/OWNER- Kansas City, Missouri, a constitutionally chartered municipal corporation, with which CONTRACTOR has entered into the Contract and for whom the Work is to be provided.

13. CITY's Representative- Person or agency designated to act for the Director as provided in these Contract Documents.

14. Consultant- Person, firm or corporation having a contract with CITY or DESIGN PROFESSIONAL to furnish services as an independent professional associate or Consultant with respect to the Project and who's identified as such in the Supplementary Conditions.

The Consultant(s) is identified and their seals affixed on the Certification Page(s). The certifications describe the respective responsibilities for the Drawings and Specifications prepared by the Consultant(s) and are incorporated into this Contract.

15. Contract- The entire and integrated written agreement between CITY and CONTRACTOR concerning the Work that incorporates all Contract Documents. The Bid Form/Contract submitted by Bidder is the Contract between CITY and CONTRACTOR upon execution by CITY. The Contract supersedes prior negotiations, representations, or agreements, whether written or oral.

16. Contract Documents- The Contract Documents establish the rights and obligations of the parties and include the Contract, Addenda (which pertain to the Contract Documents), CONTRACTOR's Bid Form/Contract (including documentation accompanying the Bid and any post Bid documentation submitted prior to the Notice of Intent to Contract), the Construction Project Instructions, the Contractor's Utilization Plan/Request for Waiver, the Notice to Proceed, the Bonds, these General Conditions, the Supplementary Conditions, the Specifications and the Drawings as the same are more specifically identified in the Project Manual and the certification page(s) of the DESIGN PROFESSIONAL and Consultant(s), together with approved project baseline schedule and amendments thereto and all Written Amendments, Change Orders, Work Change Directives, and DESIGN PROFESSIONAL's written interpretations and clarifications issued on or after the Effective Date of the Contract, and approved Shop Drawings. Reports and drawings of subsurface and physical conditions are not Contract Documents. Only printed or hard copies of the items listed in this Paragraph are Contract Documents. Files in electronic media format of text, data, graphics, and the like that may be furnished by CITY to CONTRACTOR are not Contract Documents, except project schedules submitted by CONTRACTOR and approved by CITY.

17. Contract Price- The money payable by CITY to CONTRACTOR for completion of the Work in accordance with the Contract Documents as stated in the Agreement.

18. Contract Times- The number of days or the dates stated in the Supplementary Conditions: (a) to achieve Substantial Completion, and (b) to complete the Work so that it is ready for final payment as evidenced by CITY's Representative's written recommendation of final payment.

19. CONTRACTOR- The person, firm, partnership, company, corporation or association licensed or otherwise authorized by law to do business in Missouri, with whom CITY has entered into the Agreement.

20. Day- Shall constitute a Calendar Day.

21. DESIGN PROFESSIONAL- Architect, Engineer or other licensed professional who is either employed by or has contracted with CITY to serve in a design capacity and whose Consultants, members, partners, employees or agents have prepared and sealed the Drawings and Specifications.

The DESIGN PROFESSIONAL(s) is identified and their seals affixed on the Certification Page(s). The certifications describe the respective responsibilities for the Drawings and Specifications prepared by the DESIGN PROFESSIONAL and are incorporated into this Contract.

22. DESIGN PROFESSIONAL's Project Representative- The authorized representative of DESIGN PROFESSIONAL who may be assigned to the Site or any part thereof.

23. Director- The term Director shall mean the duly appointed executive officer of a department of City who is empowered by the City Charter or by the City Council to enter into a contract on behalf of City, or to grant a permit for improvements to land owned by City. A Director is authorized to delegate this authority to a City employee so designated in writing.

24. Drawings- The drawings which graphically show the scope, extent and character of the Work to be furnished and performed by CONTRACTOR and which have been prepared by DESIGN PROFESSIONAL and are included in the Contract Documents. Shop Drawings are not Drawings as so defined.

25. Effective Date of the Contract- The date indicated in the Contract on which it becomes effective, but if no such date is indicated it means the date on which the Contract is fully executed by CITY.

26. General Requirements- Sections of Division 1 of the Specifications. The General Requirements pertain to all sections of the Specifications.

27. Hazardous Environmental Condition- The presence at the Site of Asbestos, Lead-Based Paint, PCBs, Petroleum, Hazardous Waste, or Radioactive Material in such quantities or circumstances that may present a substantial danger to persons or property exposed thereto in connection with the Work.

28. Hazardous Waste- The term Hazardous Waste shall have the meaning provided in Section 1004 of the Solid Waste Disposal Act (42 USC Section 6903) as amended from time to time.

29. Laws or Regulations- Any and all applicable laws, rules, regulations, ordinances, codes and orders of any and all governmental bodies, agencies, authorities and courts having jurisdiction.

30. Lead-Based Paint- Any paint, varnish, stain, or other applied coating that has one (1) mg or more of lead per square centimeter. The terms "leaded paint" and "lead-containing paint" are synonymous with Lead-Based Paint.

31. Liens- Liens, charges, security interests or encumbrances upon real property or personal property.

32. Milestone- A principal event specified in the Contract Documents relating to an intermediate completion date or time prior to Substantial Completion of all the Work.

33. Notice of Intent to Contract- The written notice by CITY to the apparent successful Bidder stating that upon compliance by that apparent successful Bidder with the conditions in the Bid Documents enumerated, within the time specified, and upon enactment of an appropriate ordinance or resolution, CITY will sign and deliver the Contract.

34. Notice to Proceed- A written notice given by CITY to CONTRACTOR fixing the date on which the Contract Times will commence to run and on which CONTRACTOR shall start to perform CONTRACTOR's obligations under the Contract Documents.

35. Partial Utilization- Use by CITY of a substantially completed part of the Work for the purpose for which it is intended (or a related purpose) prior to Substantial Completion of all the Work.

36. PCBs- Polychlorinated biphenyls.

37. Petroleum- Petroleum, including crude oil or any fraction thereof which is liquid at standard conditions of temperature and pressure (60 degrees Fahrenheit and 14.7 pounds per square inch absolute), such as oil, petroleum, fuel oil, oil sludge, oil refuse, gasoline, kerosene, and oil mixed with other non-Hazardous Wastes and crude oils.

38. Project- The total construction of which the Work to be provided under the Contract Documents may be the whole, or a part as indicated elsewhere in the Contract Documents.

39. Project Manual- The documentary information prepared for bidding and constructing the Work. A listing of the contents of the Project Manual may be issued in one or more volumes and is contained in the table(s) of contents.

40. Radioactive Material- Source, special nuclear, or byproduct material as defined by the Atomic Energy Act of 1954 (42 USC Section 2011 et seq.) as amended from time to time.

41. Samples- Physical examples of materials, equipment, or workmanship that are representative of some portion of the Work and which establish the standards by which such portion of the Work will be judged.

42. Shop Drawings- All drawings, diagrams, illustrations, schedules and other data or information which are specifically prepared or assembled by or for CONTRACTOR and submitted by CONTRACTOR to illustrate some portion of the Work.

43. Site- Lands or areas indicated in the Contract Documents as being furnished by CITY upon which the Work is to be performed, including rights-of-way and easements for access thereto, and such other lands furnished by CITY which are designated for the use of CONTRACTOR.

44. Specifications- Those portions of the Contract Documents consisting of written technical descriptions of materials, equipment, construction systems, standards and workmanship as applied to the Work and certain administrative details applicable thereto.

45. Subcontractor- Any individual, firm, partnership, company, corporation or association licensed or otherwise authorized by law to do business in Missouri, to whom CONTRACTOR, with written notification to CITY, has entered into an agreement to perform a part of the Work.

46. Substantial Completion- When Work (or a specified part thereof) has progressed to the point where, in the opinion of DESIGN PROFESSIONAL as evidenced by DESIGN PROFESSIONAL's definitive certificate of Substantial Completion, it is sufficiently complete, in accordance with the Contract Documents, so that the Work (or specified part) can be utilized for the purposes for which it is intended. The terms "substantially complete" and "substantially completed" as applied to all or part of the Work refer to Substantial Completion thereof.

47. Supplementary Conditions- The part of the Contract Documents which amends and/or supplements these General Conditions.

48. Supplier- A manufacturer, fabricator, supplier, distributor, materialman or vendor having a direct contract with CONTRACTOR or with any Subcontractor to furnish materials or equipment to be incorporated into the Work by CONTRACTOR or any Subcontractor.

49. Underground Facilities- All pipelines, conduits, ducts, cables, wires, manholes, vaults, tanks, tunnels or other such facilities or attachments, and any encasements containing such facilities which have been installed underground to furnish any of the following services or materials: electricity, gases, steam, liquid petroleum products, telephone or other communications, cable television, water, wastewater, storm water, other liquids or chemicals, or traffic or other control systems.

50. Unit Price Work- Work to be paid for on the basis of unit prices.

51. Work- The entire completed construction or the various separately identifiable parts thereof required to be furnished under the Contract Documents. Work includes and is the result of performing or furnishing labor, and furnishing and incorporating material and equipment into the construction, and furnishing documents, all as required by the Contract Documents.

52. Work Change Directive- A written directive to CONTRACTOR, issued on or after the Effective Date of the Contract, signed by CITY and recommended by DESIGN PROFESSIONAL, ordering an addition, deletion or revision in the Work, or responding to differing or unforeseen subsurface or physical conditions under which the Work is to be performed, or to emergencies. A Work Change Directive will not change the Contract Price or the Contract Times, but is evidence that the parties expect that the change directed or

documented by a Work Change Directive will be incorporated in a subsequently issued Change Order following negotiations by the parties as to its effect, if any, on the Contract Price or Contract Times.

53. Work Day - Any day during which the CONTRACTOR is able to work a period of six (6) hours or more. Days that are not Work Days are days during which the CONTRACTOR is unable to work for a period of six (6) hours by reason of strikes, boycotts, labor disputes, embargoes, unusual delays in transportation or shortage of material, acts of God, acts of the public enemy, acts of superior governmental authority, weather conditions, riots, rebellion, sabotage, or any other circumstances for which CONTRACTOR is not responsible or which is not within its control. Saturdays, Sundays, and holidays on which the CONTRACTOR's forces engage in Work requiring the presence of an inspector, will be considered as Work Days.

54. Written Amendment- A written statement modifying the Contract Documents, signed by CITY and CONTRACTOR on or after the Effective Date of the Contract and normally dealing with the non-engineering or non-technical rather than strictly construction-related aspects of the Contract Documents.

1.02 Terminology

A. Intent of Certain Terms or Adjectives

1. Whenever in the Contract Documents the terms "as ordered," "as directed," "as required," "as allowed," "as approved," or terms of like effect or import are used, or the adjectives "reasonable," "suitable," "acceptable," "proper" or "satisfactory" or adjectives of like effect or import are used to describe a requirement, direction, review or judgment of DESIGN PROFESSIONAL as to the Work, it is intended that such requirement, direction, review or judgment will be solely to evaluate, in general, the completed Work for compliance with the requirements of and information in the Contract Documents and conformance with the design concept of the completed Project as a functioning whole as shown or indicated in the Contract Documents (unless there is a specific statement indicating otherwise). The use of any such term or adjective shall not be effective to assign to DESIGN PROFESSIONAL any duty or authority to supervise or direct the furnishing or performance of the Work or any duty or authority to undertake responsibility contrary to the provisions of Paragraph 9.08 or any other provision of the Contract Documents.

B. Defective

1. The word "defective," when modifying the word "Work," refers to Work that is unsatisfactory, faulty or deficient, in that it does not conform to the Contract Documents, or does not meet the requirements of any inspection, reference standard, test or approval referred to in the Contract Documents, or has been damaged prior to CITY 's Representative's recommendation of final payment (unless responsibility for the protection thereof has been assumed by CITY at Substantial Completion in accordance with Paragraph 14.04 or 14.05).

C. Furnish, Install, Perform, Provide

1. The word "furnish," when used in connection with services, materials, or equipment, shall mean to supply and deliver said services, materials, or equipment to the Site (or some other specified location) ready for use or installation and in usable or operable condition.

2. The word "install," when used in connection with services, materials, or equipment, shall mean to put into use or place in final position said services, materials, or equipment complete and ready for intended use.

3. The words "perform" or "provide," when used in connection with services, materials, or equipment, shall mean to furnish and install said services, materials, or equipment complete and ready for intended use.

4. When “furnish,” “install,” “perform,” or “provide” is not used in connection with services, materials, or equipment in a context clearly requiring an obligation of CONTRACTOR, “provide” is implied.

D. Unless stated otherwise in the Contract Documents, words and phrases which have a well-known technical or construction industry or trade meanings are used in the Contract Documents in accordance with such recognized meaning.

ARTICLE 2 PRELIMINARY MATTERS

2.01 Delivery of Bonds

A. CONTRACTOR shall deliver to CITY such Bonds as CONTRACTOR may be required to furnish.

2.02 Evidence of Insurance

A. CONTRACTOR shall deliver to CITY certificates of insurance or other evidence of insurance that CITY may request, which CONTRACTOR is required to purchase and maintain in accordance with Article 5 or any other applicable provision in the Contract Documents.

2.03 Copies of Documents

A. CITY shall furnish to CONTRACTOR one (1) copy of the Drawings and Specifications, including addenda.

2.04 Commencement of Contract Times; Notice to Proceed

A. The Contract Times will commence to run on the date indicated in the Notice to Proceed.

2.05 Starting the Work

A. CONTRACTOR shall start to perform the Work on the date when the Contract Times commence to run, but no Work shall be done at the Site prior to the date on which the Contract Times commence to run, unless otherwise indicated in the Notice to Proceed.

2.06 Before Starting Construction

A. CONTRACTOR's Review of Contract Documents: Before undertaking each part of the Work, CONTRACTOR shall carefully study and compare the Contract Documents and check and verify pertinent figures shown thereon and all applicable field measurements. CONTRACTOR shall promptly report in writing to DESIGN PROFESSIONAL any conflict, error, ambiguity or discrepancy which CONTRACTOR may discover and shall obtain a written interpretation or clarification from DESIGN PROFESSIONAL before proceeding with any Work affected thereby. CONTRACTOR shall not be liable to CITY or DESIGN PROFESSIONAL for failure to report any conflict, error, ambiguity or discrepancy in the Contract Documents, unless CONTRACTOR knew or reasonably should have known thereof.

B. Preliminary Schedules: Within ten (10) days after the Effective Date of the Contract, or on such later date as CITY's Representative shall provide in writing, CONTRACTOR shall submit to CITY's Representative for review:

1. Preliminary Project Schedule: CONTRACTOR shall submit a proposed project schedule for CITY's acceptance. The proposed project schedule shall include a detailed and comprehensive construction schedule utilizing a critical path method diagram network that (a) shows all major procurement and construction elements and phases of the Project; (b) breaks down each element or phase by trade; (c) shows early and late starts so that all float time will be accurately identified; (d) all other activities necessary for the timely completion of the Project in accordance with the scheduled dates for Substantial and Final Completion; and (e) highlights the project's critical path. CITY's acceptance is expressly limited to CITY's acknowledgement that, based upon CITY's limited review, the dates of Substantial

Completion and Milestone dates are acceptable. After final acceptance of the preliminary project schedule by the CITY, it shall be considered the project baseline schedule pursuant to Paragraph 2.07(B).

2. Preliminary schedule of Shop Drawings and Sample submittals which will list each required submittal and the times for submitting, reviewing and processing such submittal; and

3. Preliminary 01290.02 Schedule of Values for all of the Work which will include quantities and prices of items which when added together equals the Contract Price and will subdivide the Work into component parts in sufficient detail to serve as the basis for progress payments during performance of the Work. Such prices will include an appropriate amount of overhead and profit applicable to each item of Work.

C. Preconstruction Conference: Before any Work at the Site may be started, a conference attended by CONTRACTOR, DESIGN PROFESSIONAL and others, as appropriate, will be scheduled by CITY's Representative to establish a working understanding among the parties as to the Work and to discuss the schedules referred to in Paragraph 2.06 B, procedures for handling Shop Drawings and other submittals, processing Applications for Payment, maintaining required records, Claims process, dispute resolution or any other applicable provisions of the Contract Documents.

2.07 Acceptable Schedules

A. Acceptable schedule: The Contractor shall update and submit to the CITY for review the preliminary schedule within seven (7) Calendar Days after the Notice to Proceed.

1. The CITY shall review and make any necessary comments and/or adjustments to the updated preliminary schedule. The Contractor shall incorporate the CITY's comments and resubmit the updated preliminary schedule within seven (7) Calendar Days from receipt of the CITY's comments.

B. Project Baseline Schedule: The accepted updated preliminary schedule shall be considered the project baseline schedule and shall be used by the CONTRACTOR for planning, scheduling, managing, and executing the Work. The project baseline schedule shall not be changed without the written consent of CITY. The project baseline schedule may be further modified by the Supplemental Conditions.

C. CONTRACTOR's schedule of values will be acceptable to CITY's Representative as to form and substance if it provides a reasonable allocation of the Contract Price to component parts of the Work.

ARTICLE 3 CONTRACT DOCUMENTS : INTENT, AMENDING, REUSE

3.01 Intent

A. The Contract Documents comprise the entire Contract between CITY and CONTRACTOR concerning the Work.

B. It is the intent of the Contract Documents to describe a functionally complete Project (or part thereof) to be constructed in accordance with the Contract Documents. Any Work, materials or equipment that may reasonably be inferred from the Contract Documents or from prevailing custom or trade usage as being required to produce the intended result will be furnished and performed whether or not specifically called for at no additional cost to CITY. Clarifications and interpretations of the Contract Documents shall be issued by DESIGN PROFESSIONAL as provided in Paragraph 9.03.

C. Correlation and intent of documents: The Drawings and Specifications are intended to supplement each other. Any Work shown on the Drawings and not mentioned in the Specifications (or vice versa) shall be as binding and shall be completed the same as if mentioned or shown on both. In the event of conflicts or discrepancies among the Contract Documents, interpretations will be based on the following priorities:

1. Change Orders and Written Amendments
2. Project Baseline Schedule Requirements
3. Approved Shop Drawings
4. Addenda, with those of later date having precedence over those of earlier date
5. The Supplementary Conditions
6. The General Conditions
7. Drawings and Specifications

D. In the case of an inconsistency between Drawings and Specifications, the requirements of the Specifications shall govern. If Drawings are in conflict, larger scale details shall govern over smaller or no-scale Drawings. If Specification sections are in conflict with each other, the conflict shall be resolved by DESIGN PROFESSIONAL in accordance with reasonable interpretation of such documents.

E. The general character of the detailed Work is shown on the Drawings, but minor modifications may be made in the full size or scale details. Where the word "similar" occurs on the Drawings, it shall be used in its general sense and not as meaning identical, and all details shall be worked out in relation to their location and their connection to the other parts of the Work. Where on any Drawings a portion of the Work is drawn out and the remainder is indicated in outline, the parts drawn out shall apply also to all other like portions of the Work. Where ornaments or other details are indicated by starting only, such details shall be continued throughout the courses or parts in which they occur and shall also apply to all other similar parts in the Work, unless otherwise indicated.

3.02 Reference to Standards and Specifications of Technical Societies

A. Reference to standards, specifications, manuals or codes of any technical society, organization or association, or to Laws or Regulations, whether such reference be specific or by implication, shall mean the latest standard, specification, manual, code or Laws or Regulations in effect at the time of opening of Bids (or on the date of CONTRACTOR's proposal if there are no Bids), except as may be otherwise specifically stated in the Contract Documents.

1. No provision of any such standard, specification, manual, code or instruction of Supplier shall be effective to change the duties or responsibilities of CITY, CONTRACTOR or DESIGN PROFESSIONAL, or any of their Subcontractors, Consultants, agents, or employees from those set forth in the Contract Documents, nor shall it be effective to assign to CITY or DESIGN PROFESSIONAL or any of their Consultants, agents or employees any duty or authority to supervise or direct the furnishing or performance of the Work or any duty or authority to undertake responsibility inconsistent with the provisions of the Contract Documents.

3.03 Reporting and Resolving Discrepancies

A. Reporting Discrepancies: If, during the performance of the Work, CONTRACTOR discovers any conflict, error, ambiguity or discrepancy within the Contract Documents or between the Contract Documents and any provision of any Laws or Regulations applicable to the performance of the Work or of any standard, specification, manual, code or any instruction of any Supplier referred to in Paragraph 6.07, CONTRACTOR shall report it immediately to DESIGN PROFESSIONAL in writing. CONTRACTOR shall not proceed with the Work affected thereby (except in an emergency as authorized by Paragraph 6.17) until an amendment or supplement to the Contract Documents has been issued by one of the methods indicated in Paragraph 3.04; provided, however, that CONTRACTOR shall not be liable to CITY or DESIGN PROFESSIONAL for failure to report any such conflict, error, ambiguity or discrepancy unless CONTRACTOR knew or reasonably should have known thereof.

B. Resolving Discrepancies. The provisions of the Contract Documents shall take precedence in resolving any conflict, error, ambiguity or discrepancy between the provisions of the Contract Documents and:

1. the provisions of any standard, specification, manual, code or instruction (whether or not specifically incorporated by reference in the Contract Documents); or
2. the provisions of any Laws or Regulations applicable to the performance of the Work.

3.04 Amending and Supplementing Contract Documents

A. The Contract Documents may be amended to provide for additions, deletions and revisions in the Work or to modify the terms and conditions thereof in one or more of the following ways:

1. a Written Amendment or
2. a Change Order (pursuant to Article 10), whether pursuant to a Work Change Directive or otherwise.

B. The requirements of the Contract Documents may be supplemented and minor variations and deviations in the Work may be authorized, in one or more of the following ways

1. DESIGN PROFESSIONAL's approval of a Shop Drawing or Sample (pursuant to Paragraph 6.18), or
2. DESIGN PROFESSIONAL's written interpretation or clarification (pursuant to Paragraph 9.03).

3.05 Reuse of Documents

A. CONTRACTOR and any Subcontractor or Supplier or other person or organization performing or furnishing any of the Work under this Contract:

1. shall not have or acquire any title to or ownership rights in any of the Drawings, Specifications or other documents (or copies of any thereof) prepared by or bearing the seal of DESIGN PROFESSIONAL or Consultant, and
2. shall not reuse any of such Drawings, Specifications, other documents or copies thereof on extensions of the Project or any other project without written consent of CITY, and of DESIGN PROFESSIONAL or Consultant, as applicable, and specific written verification or adaptation by DESIGN PROFESSIONAL or Consultant.

This prohibition will survive final payment, completion, and acceptance of the Work, or termination or completion of the Contract. Nothing herein shall preclude CONTRACTOR from retaining copies of the Contract Documents for record purposes.

ARTICLE 4 AVAILABILITY OF LANDS; SUBSURFACE AND PHYSICAL CONDITIONS; REFERENCE POINTS

4.01 Availability of Lands

A. CITY shall furnish the Site. CITY shall identify any encumbrances or restrictions not of general application but specifically related to use of lands so furnished with which CONTRACTOR will have to comply in performing the Work. Easements for permanent structures or permanent changes in existing facilities will be obtained and paid for by CITY, unless otherwise provided in the Contract Documents. If CONTRACTOR and CITY are unable to agree on entitlement to or the amount or extent of any adjustments in the Contract Price or the Contract Times or both as a result of any delay in CITY's furnishing these lands, rights-of-way or easements, CONTRACTOR may make a Claim as provided in Article 16. CONTRACTOR shall provide for all additional lands and access thereto that may be required for temporary construction facilities or storage of materials and equipment.

4.02 Subsurface and Physical Conditions

A. Reports and Drawings: Reference is made to the Supplementary Conditions for identification of:

1. Subsurface Conditions: Those reports of explorations and tests of subsurface conditions at or contiguous to the Site that have been utilized by DESIGN PROFESSIONAL in preparing the Contract Documents; and
2. Physical Conditions: Those drawings of physical conditions in or relating to existing surface or subsurface structures at or contiguous to the Site (except Underground Facilities) that have been utilized by DESIGN PROFESSIONAL in preparing the Contract Documents.

B. Limited Reliance by CONTRACTOR on Technical Data Authorized: CONTRACTOR may rely upon the general accuracy of the technical data contained in reports and drawings of subsurface or physical conditions, but such reports and drawings are not Contract Documents. The technical data is identified in the Supplementary Conditions. Except for reliance on such technical data, CONTRACTOR may not rely upon or make any Claim against CITY, DESIGN PROFESSIONAL or any Consultant with respect to:

1. the completeness of such reports and drawings for CONTRACTOR's purposes, including, but not limited to, any aspects of the means, methods, techniques, sequences and procedures of construction to be employed by CONTRACTOR and safety precautions and programs incident thereto; or
2. other data, interpretations, opinions and information contained in such reports or shown or indicated in such drawings, or
3. any CONTRACTOR interpretation of or conclusion drawn from any technical data or any such other data, interpretations, opinions or information.

4.03 Differing Subsurface or Physical Conditions

A. Notice of Differing Subsurface or Physical Conditions. If CONTRACTOR believes that any subsurface or physical condition at or contiguous to the Site that is uncovered or revealed either:

1. is of such a nature as to establish that any technical data on which CONTRACTOR is entitled to rely as provided in Paragraphs 4.02 A and 4.02 B is materially inaccurate; or
2. is of such a nature as to require a change in the Contract Documents; or
3. differs materially from that shown or indicated in the Contract Documents; or
4. is of an unusual nature, and differs materially from conditions ordinarily encountered and generally recognized as inherent in work of the character provided for in the Contract Documents; then CONTRACTOR shall, promptly after becoming aware thereof and before further disturbing the subsurface or physical conditions or performing any Work in connection therewith (except in an emergency as required by Paragraph 6.17), notify CITY and DESIGN PROFESSIONAL in writing about such condition(s). CONTRACTOR shall not further disturb such conditions or perform any Work in connection therewith (except as aforesaid) until receipt of written order to do so.

B. DESIGN PROFESSIONAL's Review: After receipt of notice as required by Paragraph 4.03 A, DESIGN PROFESSIONAL will promptly review the pertinent conditions, determine the necessity for CITY to obtain additional exploration or tests with respect thereto and notify CITY in writing (with a copy to CONTRACTOR) of DESIGN PROFESSIONAL's findings and conclusions.

C. Possible Contract Documents Change: If CITY concludes that a change in the Contract Documents is required as a result of a condition that meets one or more of the categories in Paragraph 4.03 A, a Work Change Directive or a Change Order will be issued as provided in Article 10 to reflect and document the consequences of such change.

D. Possible Price or Times Adjustments: An equitable adjustment in the Contract Price or in the Contract Times, or both, will be allowed to the extent that the existence of a subsurface or physical condition causes an increase or decrease in CONTRACTOR's cost of, or time required for, performance of the Work; subject, however, to the following:

1. the condition must meet any one or more of the categories described in Paragraphs 4.03 A.1 through 4.03 A.4, inclusive;
2. a change in the Contract Documents pursuant to Paragraph 4.03 C will not be an automatic authorization of, nor a condition precedent to, entitlement to any such adjustments;
3. with respect to Work that is paid for on a unit price basis, any adjustment in Contract Price will be subject to the provisions of Paragraphs 9.06 and 11.04; and
4. CONTRACTOR shall not be entitled to any adjustment in the Contract Price or Contract Times if;
 - a. CONTRACTOR knew, or by the exercise of ordinary care could have known, of such conditions at the time CONTRACTOR made a final commitment to CITY with respect to Contract Price and Contract Times by the submission of a Bid; or
 - b. the existence of such condition could reasonably have been discovered or revealed as a result of any examination, investigation, exploration, test or study of the Site and contiguous areas required by the Bidding Requirements or Contract Documents to be conducted by or for CONTRACTOR prior to CONTRACTOR's making such final commitment; or
 - c. CONTRACTOR failed to give the written notice as required by Paragraph 4.03 A.

E. If CITY and CONTRACTOR are unable to agree on entitlement to, or magnitude of, an equitable adjustment in the Contract Price pursuant to Article 11 and/or Contract Times pursuant to Article 12, a Claim may be made therefore as provided in Article 16. However, CITY, DESIGN PROFESSIONAL and Consultants shall not be liable to CONTRACTOR for any costs, losses or damages (including but not limited to all fees and charges of engineers, architects, attorneys, and other professionals and all other dispute resolution costs) sustained by CONTRACTOR on or in connection with any other project or anticipated project.

4.04. Physical Conditions – Underground Facilities

A. Shown or Indicated: The information and data shown or indicated in the Contract Documents with respect to existing Underground Facilities at or contiguous to the Site is based on information and data furnished to CITY or DESIGN PROFESSIONAL by the owners of such Underground Facilities or by others.

1. CITY and DESIGN PROFESSIONAL shall not be responsible for the accuracy or completeness of any such information or data; and
2. The cost of all of the following will be included in the Contract Price and CONTRACTOR shall have full responsibility for:
 - a. reviewing and checking all such information and data,
 - b. locating all Underground Facilities shown or indicated in the Contract Documents,
 - c. coordination of the Work with the owners of such Underground Facilities during construction, and
 - d. the safety and protection of all such Underground Facilities as provided in Paragraph 6.14 and repairing any damage thereto resulting from the Work.

B. Not Shown or Indicated: If an Underground Facility is uncovered or revealed at or contiguous to the Site, and was not shown or indicated in the Contract Documents, or was

shown or indicated incorrectly in the Contract Documents, CONTRACTOR shall, promptly after becoming aware thereof and before further disturbing conditions affected thereby or performing any Work in connection therewith (except in an emergency as required by Paragraph 6.17), identify the owner of such Underground Facility and give written notice to that owner and to CITY and DESIGN PROFESSIONAL.

C. DESIGN PROFESSIONAL's Review: After receipt of notice as required by Paragraph 4.04 B, DESIGN PROFESSIONAL will promptly review the consequences of the existence of the Underground Facility and notify CITY in writing (with a copy to CONTRACTOR) of DESIGN PROFESSIONAL's findings and conclusions.

D. Possible Contract Documents Change: If CITY concludes that a change in the Contract Documents is required as a result of the existence of an Underground Facility that either was not shown, or was shown incorrectly, in the Contract Documents, a Work Change Directive or Change Order will be issued as provided in Article 10 to reflect and document the consequences of such change.

E. Possible Price or Times Adjustments: An equitable adjustment in the Contract Price or in the Contract Times, or both, will be allowed to the extent that the existence of the Underground Facility causes an increase or decrease in CONTRACTOR's cost of, or time required for, performance of the Work; subject, however, to the following:

1. a change in the Contract documents pursuant to Paragraph 4.04 D will not be an automatic authorization of, nor a condition precedent to, entitlement to any such adjustments;
2. with respect to Work that is paid for on a unit price basis, any adjustment in Contract Price will be subject to the provisions of Paragraphs 9.06 and 11.04; and
3. CONTRACTOR shall not be entitled to any adjustment in the Contract Price or Contract Times if;
 - a. CONTRACTOR knew, or by the exercise of ordinary care could have known, of the existence of the Underground Facility at the time CONTRACTOR made a final commitment to CITY with respect to Contract Price and Contract Times by the submission of a Bid; or
 - b. the existence of the Underground Facility could reasonably have been discovered or revealed as a result of any examination, investigation, exploration, test or study of the Site and contiguous areas required by the Bidding Requirements or Contract Documents to be conducted by or for CONTRACTOR prior to CONTRACTOR's making such final commitment; or
 - c. CONTRACTOR failed to give the written notice as required by Paragraph 4.04 B.

F. If CITY and CONTRACTOR are unable to agree on entitlement to, or magnitude of, an equitable adjustment in the Contract Price pursuant to Article 11 and/or Contract Times pursuant Article 12, a Claim may be made therefore as provided in Article 16. However, CITY, DESIGN PROFESSIONAL and Consultants shall not be liable to CONTRACTOR for any costs, losses or damages (including but not limited to all fees and charges of engineers, architects, attorneys, and other professionals and all other dispute resolution costs) sustained by CONTRACTOR on or in connection with any other project or anticipated project.

4.05 Reference Points

A. CITY shall provide engineering surveys to establish reference points for construction that in DESIGN PROFESSIONAL's judgment are necessary to enable CONTRACTOR to proceed with the Work. CONTRACTOR shall be responsible for laying out the Work, shall protect and preserve the established reference points and property monuments, and shall make no changes or relocations without the prior written approval of CITY. CONTRACTOR shall report to DESIGN PROFESSIONAL whenever any reference point or property monument is lost or destroyed or requires relocation because of necessary changes in grades or locations, and shall be

responsible for the accurate replacement or relocation of such reference points or property monuments by professionally qualified personnel.

4.06 Asbestos, Lead-Based Paint, PCBs, Petroleum, Hazardous Waste or Radioactive Material

A. Reports and Drawings: Reference is made to the Supplementary Conditions for the identification of those reports and drawings relating to a Hazardous Environmental Condition identified at the Site, if any, that have been utilized by the DESIGN PROFESSIONAL in the preparation of the Contract Documents.

B. Limited Reliance by CONTRACTOR on Technical Data Authorized: CONTRACTOR may rely upon the general accuracy of the technical data contained in reports and drawings relating to a Hazardous Environmental Condition at the Site, but such reports and drawings are not Contract Documents. Such technical data is identified in the Supplementary Conditions. Except for such reliance on such technical data, CONTRACTOR may not rely upon or make any Claim against CITY, DESIGN PROFESSIONAL or any Consultant with respect to:

1. the completeness of such reports and drawings for CONTRACTOR's purposes, including, but not limited to, any aspects of the means, methods, techniques, sequences and procedures of construction to be employed by CONTRACTOR and safety precautions and programs incident thereto; or
2. other data, interpretations, opinions and information contained in such reports or shown or indicated in such drawings; or
3. any CONTRACTOR interpretation of or conclusion drawn from any technical data or any such other data, interpretations, opinions or information.

C. CONTRACTOR shall not be responsible for any Hazardous Environmental Condition uncovered or revealed at the Site which was not shown or indicated in Drawings or Specifications or identified in the Contract Documents to be within the scope of the Work. CONTRACTOR shall be responsible for all Hazardous Environmental Conditions created with any materials brought to the Site by CONTRACTOR, Subcontractors, Suppliers, or anyone else for whom CONTRACTOR is responsible. CONTRACTOR shall not be entitled to an extension of the Contract Times or an increase in the Contract Price if CONTRACTOR, Subcontractor, Supplier or anyone for whom CONTRACTOR is responsible created any Hazardous Environmental Condition at the Site or in connection with the Work.

D. If CONTRACTOR encounters a Hazardous Environmental Condition at the Site or if CONTRACTOR or anyone for whom CONTRACTOR is responsible creates a Hazardous Environmental Condition at the Site, CONTRACTOR shall immediately:

1. secure or otherwise isolate such condition;
2. stop all Work in connection with such condition and in any area affected thereby (except in an emergency as required by Paragraph 6. 15); and
3. notify CITY and DESIGN PROFESSIONAL (and promptly thereafter confirm such notice in writing). CITY shall promptly consult with DESIGN PROFESSIONAL concerning the necessity for CITY to retain a qualified expert to evaluate such condition or take corrective action, if any.

E. CONTRACTOR shall neither resume Work nor be required to resume Work in connection with such condition or in any affected area until after CITY has obtained any required permits related thereto and delivered to CONTRACTOR written notice:

1. specifying that such condition and any affected area is or has been rendered safe for the resumption of Work; or
2. specifying any special conditions under which such Work may be resumed safely. If CITY and CONTRACTOR cannot agree as to entitlement to or on the amount or extent, if any, of any adjustment in Contract Price pursuant to Article 11 and/or Contract Times to

pursuant to Article 12 as a result of such Work stoppage or such special conditions under which Work is agreed to be resumed by CONTRACTOR, a Claim may be made therefore as provided in Article 16.

F. If after receipt of written notice as required in Paragraph 4.06 E, CONTRACTOR does not agree to resume Work based on a reasonable belief it is unsafe, or does not agree to resume such Work under special conditions specified in the notice, then CITY may order the portion of the Work that is in the area affected by such condition to be deleted from the Work. If CITY and CONTRACTOR cannot agree as to entitlement to or magnitude of an equitable adjustment in Contract Price pursuant to Article 11 and/or Contract Times pursuant to Article 12 as a result of deleting such portion of the Work, then a Claim may be made therefore as provided in Article 16. CITY may have such deleted portion of the Work performed by CITY's own forces or others in accordance with Article 7.

G. The provisions of Paragraphs 4.02, 4.03, and 4.04 are not intended to apply to a Hazardous Environmental Condition uncovered or revealed at the Site.

H. All materials used, whether new or salvaged, shall be asbestos-free materials. CONTRACTOR shall immediately call to the attention of the CITY's Representative any specified material or product which the CONTRACTOR knows or suspects to contain asbestos, whether new or salvaged.

ARTICLE 5 BONDS AND INSURANCE

5.01 Performance, Payment and Other Bonds

A. CONTRACTOR shall furnish Performance and Maintenance and Payment Bonds, each in an amount at least equal to the Contract Price, as set out in the Contract Documents, as security for the faithful performance and payment of all CONTRACTOR's obligations under the Contract Documents. These Bonds shall remain in effect at least until one (1) year after the date when final payment of the Contract becomes due, except as provided otherwise by Laws or Regulations or by the Contract Documents. CONTRACTOR shall also furnish such other Bonds as are required by the Supplementary Conditions.

B. All Bonds shall be in the form prescribed by the Contract Documents except as provided otherwise by Laws or Regulations. A certified copy of the agent's authority to act must accompany all Bonds signed by an agent.

C. If the surety on any Bond furnished by CONTRACTOR is declared bankrupt or becomes insolvent, or its right to do business is terminated in any state where any part of the Project is located or it ceases to meet the requirement of Paragraph 5.01 B, CONTRACTOR shall within twenty (20) days thereafter substitute another Bond and surety, both of which must be acceptable to CITY.

5.02 Licensed Sureties and Insurers

A. All Bonds and insurance required by the Contract Documents to be purchased and maintained by CITY or CONTRACTOR shall be obtained from surety or insurance companies that are duly licensed in the State of Missouri and in the jurisdiction in which the Project is located, if not in Missouri, to issue Bonds or insurance policies for the limits and coverages so required. All surety and insurance companies shall hold an A.M. Best rating of A-, V, or better.

5.03 Certificates of Insurance

A. CONTRACTOR shall deliver to CITY and DESIGN PROFESSIONAL, prior to the start of any Work at the Project Site, properly completed certificates of insurance or other evidence that the required insurance is in full force and effect, in a form acceptable to CITY. The receipt or acceptance of a certificate of insurance that does not incorporate the required terms and coverage shall not constitute a waiver by the City of the insurance requirements contained in the Contract Documents.

B. All policies of insurance (and the certificates or other evidence thereof) required to be purchased and maintained by CONTRACTOR in accordance with Paragraphs 5.04 and 5.06 will contain waiver provisions in accordance with Paragraph 5.07 A. The certificates of insurance will contain a provision stating that should any of the policies described in the certificate be cancelled before the expiration date thereof, notice will be delivered in accordance with the policy provisions.

C. If the coverage afforded is cancelled or changed or its renewal is refused, CONTRACTOR shall give at least thirty (30) days prior written notice to CITY and to each other additional insured to whom a certificate of insurance has been issued.

5.04 CONTRACTOR's Liability Insurance

A. CONTRACTOR shall purchase and maintain such liability and other insurance as is appropriate for the Work being performed and furnished, and will provide protection from claims set forth below which may arise out of or result from CONTRACTOR's performance and furnishing of the Work and CONTRACTOR's other obligations under the Contract Documents, whether it is to be performed or furnished by CONTRACTOR, any Subcontractor or Supplier, or by anyone directly or indirectly employed by any of them to perform or furnish any of the Work, or by anyone for whose acts any of them may be liable:

1. claims under workers' compensation, disability benefits and other similar employee benefit acts;
2. claims for damages because of bodily injury, occupational sickness or disease, or death of CONTRACTOR's employees;
3. claims for damages because of bodily injury, sickness or disease, or death of any person other than CONTRACTOR's employees;
4. claims for damages insured by customary personal injury liability coverage;
5. claims for damages, other than to the Work itself, because of injury to or destruction of tangible property wherever located, including loss of use resulting therefore; and
6. claims for damages because of bodily injury or death of any person or property damage arising out of the ownership, maintenance or use of any motor vehicle.

B. The policies of insurance so required by Paragraph 5.04 A, to be purchased and maintained shall:

1. with respect to insurance required by Paragraphs 5.04 A.3 through 5.04 A.5 inclusive, include as additional insureds (subject to any customary exclusion for professional liability) CITY, DESIGN PROFESSIONAL, Consultants and any other individuals or entities identified in the Supplementary Conditions to be listed as additional insureds, and include coverage for the respective officers, directors, partners, employees, agents, and other consultants and subcontractors of each and any of all such additional insureds, and the insurance afforded to these additional insureds shall provide primary coverage for all claims covered thereby;
2. include at least the specific coverages and be written for not less than the limits of liability provided in Paragraph 5.04 C or required by Laws or Regulations, whichever is greater;
3. include completed operations insurance;
4. include contractual liability insurance covering CONTRACTOR's indemnity obligations;
5. remain in effect at least until final payment and at all times thereafter when CONTRACTOR may be correcting, removing or replacing defective Work in accordance with Paragraphs 13.06 and 13.07;

6. with respect to completed operations insurance, and any insurance coverage written on a claims-made basis, remain in effect for at least two (2) years after final payment (and CONTRACTOR shall furnish CITY and each other additional insured identified in the Supplementary Conditions to whom a certificate of insurance has been issued evidence satisfactory to CITY and any such additional insured of continuation of such insurance);

7. contain a cross-liability or severability of interest clause or endorsement. Insurance covering the specified additional insureds shall be primary insurance, and all other insurance carried by the additional insureds shall be excess insurance;

8. with respect to commercial automobile liability, commercial general liability, and umbrella liability insurance, CONTRACTOR shall require its insurance carrier(s) to waive all rights of subrogation against CITY, and CITY's officers, directors, partners, employees and agents; and

9. contain a provision or endorsement that the costs of providing the insureds a defense and appeal, including attorneys' fees, as insureds, shall be supplementary and shall not be included as part of the policy limits but shall remain the insurer's responsibility.

C. Specific policies of insurance required by this Paragraph 5.04 shall include:

1. Workers' Compensation and Employers' Liability Insurance. This insurance shall protect CONTRACTOR against all claims under applicable state workers' compensation laws, including coverage as necessary for the benefits provided under the United States Longshoremen's and Harbor Workers' Act and the Jones Act. CONTRACTOR shall also be protected against claims for injury, disease, or death of employees which, for any reason, may not fall within the provisions of workers' compensation laws. This policy shall include an "all states" or "other states" endorsement. The liability limits shall be not less than:

Workers' Compensation: Statutory

Employers' liability: \$1,000,000 each occurrence

2. Commercial Automobile Liability Insurance. This insurance shall be occurrence type written in comprehensive form and shall protect CONTRACTOR, and CITY, DESIGN PROFESSIONAL and Consultants against all claims for injuries to members of the public and damage to property of others arising from the use of motor vehicles, either on or off the Project Site, whether they are owned, non-owned, or hired.

The liability limits shall be not less than: \$2,000,000

3. Commercial General Liability Insurance. This insurance shall be occurrence type written in comprehensive form acceptable to CITY. This insurance shall protect CONTRACTOR, and CITY, DESIGN PROFESSIONAL and Consultants as additional insureds, against claims arising from injuries, sickness, disease, or death of any person or damage to property arising out of performance of the Work. The policy shall also include coverage for personal injury liability; contractual liability; completed operations and products liability; and for blasting, explosion, and collapse of buildings; and damage to underground property. The liability limits for bodily injury and property damage shall be not less than:

\$2,000,000 combined single limit for each occurrence

\$2,000,000 general aggregate.

4. The insurer's costs of providing the insureds a defense and appeal as additional insureds, including attorney's fees, shall be supplementary and shall not be included as part of the policy limits but shall remain the insurer's separate responsibility.

5.05 CITY's Liability Insurance

A. In addition to the insurance required to be provided by CONTRACTOR under Paragraph 5.04, CITY, at CITY's option, may purchase and maintain at CITY's expense liability insurance

that will protect CITY against claims which may arise from operations under the Contract Documents.

5.06 Property Insurance

A. Unless otherwise provided in the Supplementary Conditions, CONTRACTOR shall purchase and maintain property insurance on the Work at the Site in the amount of the full replacement cost thereof (subject to such deductible amounts as may be provided in the Supplementary Conditions or required by Laws or Regulations). This insurance shall:

1. include the interests of CITY, CONTRACTOR, Subcontractors, and any other persons or entities identified in the Supplementary Conditions, each of whom is deemed to have an insurable interest and shall be listed as an insured or additional insured;
2. be written on a Builder's Risk "all-risk" or open peril or special causes of loss policy form that shall at least include insurance for physical loss or damage to the Work, temporary buildings, falsework and materials and equipment in transit, and shall insure against at least the following perils or causes of loss: fire, lightning, extended coverage, theft, vandalism and malicious mischief, earthquake, tornado, collapse, debris removal, demolition occasioned by enforcement of Laws or Regulations, water damage, damage caused by frost and freezing, and acts of God;
3. be maintained in effect until final payment is made unless otherwise agreed to in writing by CITY with thirty (30) days written notice to each other additional insured to whom a certificate of insurance has been issued.

B. CITY shall not be responsible for purchasing and maintaining any property insurance to protect the interests of CONTRACTOR, Subcontractors or others involved in the Work to the extent of any deductible amounts. The risk of loss within the deductible amounts will be borne by CONTRACTOR, Subcontractor or others suffering any such loss and if any of them wishes property insurance coverage within the limits of such amounts, each may purchase and maintain it at the purchaser's own expense.

5.07 Waiver of Rights

A. CITY and CONTRACTOR intend that all policies purchased in accordance with Paragraphs 5.04 and 5.06 will protect CITY, CONTRACTOR, DESIGN PROFESSIONAL Consultants, Subcontractors, and all other persons or entities identified in the Supplementary Conditions to be listed as insureds or additional insureds in such policies and will provide primary coverage for all losses and damages caused by the perils covered thereby. All such policies shall contain provisions to the effect that in the event of payment of any loss or damage the insurers will have no rights of recovery against any of the insureds or additional insureds thereunder. CITY and CONTRACTOR waive all rights against each other and their respective officers, directors, partners, employees and agents for all losses and damages caused by, arising out of or resulting from any of the perils covered by such policies and any other property insurance applicable to the Work, but only to the extent of insurance coverage; and, in addition, waive all such rights against DESIGN PROFESSIONAL, Consultants, Subcontractors, and all other persons or entities identified in the Supplementary Conditions to be listed as insureds or additional insureds (and the officers, directors, partners, employees, agents, and other consultants and subcontractors of any and each of them) under such policies for losses and damages so caused and covered by insurance. None of the above waivers shall extend to the rights that any party making such waiver may have to the proceeds of insurance held by CITY as trustee or otherwise payable under any policy so issued. None of the above waivers shall apply if specifically in conflict with Laws and Regulations.

5.08 Receipt and Application of Insurance Proceeds

A. Any insured loss under the property insurance will be adjusted with CITY and made payable to CITY as fiduciary for the insureds, as their interests may appear, subject to the requirements of any indentures of indebtedness entered into by CITY.

B. CITY as fiduciary shall have power to adjust and settle any loss with the insurers unless one of the parties in interest shall object to CITY's exercise of this power in writing within fifteen (15) days after the occurrence of loss. If such objection is made, CITY as fiduciary shall make settlement with the insurers in accordance with such agreement as the parties in interest may reach. If no such agreement among the parties in interest is reached, CITY as fiduciary shall adjust and settle the loss with the insurers.

5.09 Partial Utilization – Property Insurance

A. If CITY finds it necessary to occupy or use a portion or portions of the Work prior to Substantial Completion of all the Work, such use or occupancy may be accomplished in accordance with Paragraph 14.05; provided that no such use or occupancy shall commence before the insurers providing the property insurance have acknowledged notice thereof and in writing effected any changes in coverage necessitated thereby. The insurers providing the property insurance shall consent by endorsement on the policy or policies, but the property insurance shall not be canceled or permitted to lapse on account of any such partial use or occupancy.

ARTICLE 6 CONTRACTOR'S RESPONSIBILITIES

6.01 Indemnification

A. For purposes of this Paragraph 6.01 only, the following terms shall have the meanings listed:

1. Claims means all claims, damages, liability, losses, costs and expenses, including court costs and reasonable attorneys' fees, including attorney's fees incurred by the City in the enforcement of this indemnity obligation.

2. CONTRACTOR'S Agents means CONTRACTOR's officers, employees, sub-consultants, subcontractors, successors, assigns, invitees, and other agents.

3. CITY means CITY, its Program Manager/Construction Advisor and any of their agents, officials, officers, employees and program managers or construction advisors.

B. CONTRACTOR's obligations under this Paragraph with respect to indemnification for acts or omissions, including negligence, of CITY, shall be limited to the coverage and limits of insurance that CONTRACTOR is required to procure and maintain under this Contract. CONTRACTOR affirms that it has had the opportunity to recover the costs of the liability insurance required in this Contract in its contract price.

C. CONTRACTOR shall defend, indemnify and hold harmless CITY from and against all Claims arising out of or resulting from all acts or omissions in connection with this Contract caused in whole or in part by CONTRACTOR or CONTRACTOR's Agents, regardless of whether or not caused in part by any act or omission, including negligence, of OWNER.

D. In any and all Claims against CITY, DESIGN PROFESSIONAL, CONSULTANT, or any of their respective agents, officers, directors or employees by any employee (or the survivor or personal representative of such employee) of CONTRACTOR, any Subcontractor, any Supplier, any person or organization directly or indirectly employed by any of them to perform or furnish any of the Work, or anyone for whose acts any of them may be liable, the indemnification obligation under Paragraph 6.01 C shall not be limited in any way by any limitation on the amount or type of damages, compensation or benefits payable by or for CONTRACTOR or any such Subcontractor, Supplier or other person or organization under workers' compensation acts, disability benefit acts or other employee benefit acts.

E. The indemnification obligations of CONTRACTOR under Paragraph 6.01 C shall not extend to liability arising out of, resulting from, or caused by the professional negligence, errors or omissions of DESIGN PROFESSIONAL, CONSULTANT, or any of their respective agents, officers, directors or employees.

6.02 Supervision and Superintendence

A. CONTRACTOR shall supervise, inspect and direct the Work competently and efficiently, devoting such attention thereto and applying such skills and expertise as may be necessary to perform the Work in accordance with the Contract Documents. CONTRACTOR shall be solely responsible for the means, methods, techniques, sequences and procedures of construction, but CONTRACTOR shall not be responsible for the negligence of others in the design or specification of a specific means, method, technique, sequence or procedure of construction which is shown or indicated in and expressly required by the Contract Documents. CONTRACTOR shall be responsible to see that the completed Work complies accurately with the Contract Documents.

B. At all times during the progress of the Work, CONTRACTOR shall assign a competent resident superintendent of the Work, who shall not be replaced without written request to and approval by CITY except under extraordinary circumstances. The superintendent will be CONTRACTOR's representative at the Site and shall have authority to act on behalf of CONTRACTOR. All communications given to or received from the superintendent shall be binding on CONTRACTOR.

C. If it is determined to be in the best interest of the Work, CONTRACTOR shall replace the project manager, resident superintendent or any other employee of the CONTRACTOR, Subcontractors, Suppliers or other persons or organizations performing or furnishing any of the Work on the project upon written request by the CITY.

6.03 Services, Working Hours, Labor, Materials and Equipment

A. CONTRACTOR shall provide competent, suitably qualified personnel to survey, lay out and construct or perform the Work as required by the Contract Documents. CONTRACTOR shall at all times maintain good discipline and order at the Site. Except as otherwise required for the safety or protection of persons or the Work or property at the Site or adjacent thereto, and except as otherwise indicated in the Contract Documents, all Work at the Site shall be performed during regular working hours. CONTRACTOR shall not permit overtime work or the performance of Work on Saturday, Sunday or any legal holiday without CITY's written consent given after prior written notice to DESIGN PROFESSIONAL.

B. Unless otherwise specified in Division 1, General Requirements, CONTRACTOR shall furnish and assume full responsibility for all services, materials, equipment, labor, transportation, construction equipment and machinery, tools, appliances, fuel, power, light, heat, telephone, water, sanitary facilities, temporary facilities and all other facilities and incidentals necessary for the furnishing, performance, testing, start-up and completion of the Work.

C. All materials and equipment shall be of good quality and new, except as otherwise provided in the Contract Documents. All warranties and guarantees specifically called for by the Specifications shall expressly run to the benefit of CITY. If required by DESIGN PROFESSIONAL, CONTRACTOR shall furnish satisfactory evidence (including reports of required tests) as to the source, kind, and quality of materials and equipment. All materials and equipment shall be stored, applied, installed, connected, erected, used, cleaned and conditioned in accordance with instructions of the applicable Supplier, except as otherwise provided in the Contract Documents.

D. It is the policy of the CITY that any manufactured goods or commodities used or supplied in the performance of this Contract and any subcontract hereto shall be manufactured or produced in the United States whenever possible.

6.04 Progress Schedule

A. CONTRACTOR shall adhere to the progress schedule established in accordance with Article 2 as it may be adjusted from time to time as provided below:

1. CONTRACTOR shall provide, at least once every thirty (30) calendar days, updated information on the project schedule, including thirty (30) day look ahead schedules, projected variances per event category and per Subcontractor, identification of all variances and calculation of the number of Days difference between the as-built critical path and the project schedule critical path

2. CONTRACTOR shall, with each application for payment, provide completed monthly updated status report for the previous month on the project schedule and updated information indicating as-built and as-planned conditions. The updated information on the project schedule shall not modify any Milestone dates in the project schedule that CITY has previously approved. The updated information required is a condition precedent to payment pursuant to paragraph 14.02 and shall include at a minimum:

- a. a concise statement of the outlook for meeting project schedule dates and the reasons for any change in outlook from the previous report;
- b. a review of any significant technical problems encountered during the month;
- c. an explanation of any corrective action taken or proposed; and
- d. a summary of any Claims anticipated by CONTRACTOR with respect to the Work, including the anticipated costs and schedule impacts of any such Claims.

6.05 Recovery Schedules

A. If the CONTRACTOR should:

1. fail, refuse or neglect to supply a sufficient number of workers or to deliver the materials or equipment with such promptness as to prevent the delay in the progress of the Work;
2. fail in any respect to commence and diligently prosecute the Work in accordance with the approved baseline project schedule in order to achieve substantial completion;
3. fail to commence, prosecute, finish, deliver or install the different portions of the Work on time as specified in the approved baseline project schedule; or
4. fail in the performance of any of the material covenants of the Contract Documents;

CITY shall have the right to direct the CONTRACTOR, upon seven (7) calendar days notice, to prepare a written recovery plan, for CITY's approval, to accelerate the Work in order to conform to the approved baseline project schedule, including, without limitation, providing additional labor or expediting delivery of materials, performing overtime or re-sequencing the Work without adjustments to the Contract value. Upon CITY's approval of the recovery plan, CONTRACTOR shall accelerate the Work in accordance with the plan.

B. Proposed recovery schedules shall be submitted to the CITY as a separate project plan for review and approval by CITY prior to incorporation into the approved baseline schedule. The recovery schedule shall be submitted in a format compatible with the baseline schedule format. Each proposed revision shall be submitted as a separate schedule, with the following minimum requirements:

1. A critical path method diagram showing revised and affected activities or Milestones.
2. An activity report for all revised and affected activities or Milestones.

C. Upon acceptance of the recovery schedule by CITY, data shall be added or revised for all new or revised activities and incorporated into the approved baseline project schedule.

6.06 Substitutes and “Or-Equal” Items

A. Materials or equipment: Whenever an item of material or equipment is specified or described in the Contract Documents by using the name of a proprietary item or the name of a particular Supplier, the specification or description is intended to establish the type, function, appearance and quality required. Unless the specification or description contains, or is followed by, words reading that no like, equivalent or “or-equal” item or no substitution is permitted, other items of material or equipment or material or equipment of other Suppliers may be submitted to CITY for review by CITY’s Representative under the following circumstances:

1. “Or-Equal”: If, prior to receipt of Bids, Bidder proposes an item of material or equipment as functionally equal to that named and sufficiently similar so that no change in related Work will be required, CITY’s Representative may request DESIGN PROFESSIONAL to consider it as an “or-equal” item. DESIGN PROFESSIONAL will review and recommend the acceptance, or rejection, of the proposed item to the CITY’s Representative. For the purposes of this Paragraph, a proposed item of material or equipment will be considered functionally equal to an item so named if:

a. in the exercise of reasonable judgment DESIGN PROFESSIONAL determines that:

(1) it is at least equal in quality, durability, appearance, strength, and design characteristics; and

(2) it will reliably perform at least equally well the function imposed by the design concept of the completed Project as a functioning whole; and

b. Bidder certifies that:

(1) there is no increase in cost to the CITY; and

(2) it will conform substantially, even with deviations, to the detailed requirements of the item named in the Contract Documents.

If the CITY’s Representative approves the proposed item, it may be accepted by CITY.

2. Substitute Items: If CONTRACTOR proposes an item of material or equipment as a substitute item, then CONTRACTOR shall submit sufficient information as provided below to allow CITY’s Representative to determine that the item of material or equipment proposed is essentially equivalent to that named and an acceptable substitute therefore. The procedure for review by the CITY’s Representative will include the following as supplemented in the General Requirements and as CITY’s Representative may determine is appropriate under the circumstances:

a. Requests for review of proposed substitute items of material or equipment will not be accepted by CITY’s Representative from anyone other than CONTRACTOR.

b. If CONTRACTOR wishes to furnish or use a substitute item of material or equipment, CONTRACTOR shall first make written application to CITY’s Representative for acceptance thereof.

c. In the application, CONTRACTOR shall certify that the proposed substitute will perform adequately the functions and achieve the results called for by the general design, be similar in substance to that specified and be suited to the same use as that specified. The application will state the extent, if any, to which the evaluation and acceptance of the proposed substitute will impact CONTRACTOR’s achievement of Substantial Completion, whether or not acceptance of the substitute for use in the Work will require a change in any of the Contract Documents (or in the provisions of any other direct contract with CITY for work on the Project) to adapt the design to the proposed substitute and whether or not incorporation or use of the substitute in connection with the Work is subject to payment of any license fee or royalty.

d. All variations of the proposed substitute from that specified will be identified in the application and available maintenance, repair and replacement service will be indicated. The application will also contain an itemized estimate of all costs or credits that will result directly or indirectly from acceptance of such substitute, including costs of redesign and claims of other contractors affected by the resulting change, all of which will be considered by CITY's Representative in evaluating the proposed substitute. CITY's Representative may require CONTRACTOR to furnish additional data about the proposed substitute.

If the CITY's Representative approves the proposed item, CITY may accept it.

B. Substitute Construction Methods or Procedures: If a specific means, method, technique, sequence or procedure of construction is shown or indicated in and expressly required by the Contract Documents, CONTRACTOR may furnish or utilize a substitute means, method, technique, sequence or procedure of construction acceptable to DESIGN PROFESSIONAL. CONTRACTOR shall notify CITY and submit sufficient information to allow DESIGN PROFESSIONAL, in DESIGN PROFESSIONAL's sole discretion, to determine that the substitute proposed is equivalent to that expressly called for by the Contract Documents.

C. Expenses: Bidder shall provide all data in support of any "or equal" at Bidder's expense, and CONTRACTOR shall provide all data in support of any proposed substitute at CONTRACTOR's expense.

D. Evaluation: DESIGN PROFESSIONAL and CITY's Representative will be allowed a reasonable time within which to evaluate each proposal or submittal made pursuant to Paragraphs 6.06 A, and 6.06 B. CITY will be the sole judge of acceptability. No "or-equal" or substitute will be ordered, installed or utilized without CITY's prior written acceptance which will be evidenced by either a Change Order or an approved Shop Drawing. CITY may require CONTRACTOR to furnish at CONTRACTOR's expense, a special performance guarantee or other surety with respect to any "or-equal" substitute. DESIGN PROFESSIONAL will record time required by DESIGN PROFESSIONAL and Consultants in evaluating substitutes proposed or submitted by CONTRACTOR pursuant to Paragraphs 6.06 A and 6.06 B and in making changes in the Contract Documents (or in the provisions of any other direct contract with CITY for work on the Project) occasioned thereby. Whether or not CITY accepts a substitute so proposed or submitted by CONTRACTOR, CONTRACTOR shall reimburse CITY for the reasonable charges of DESIGN PROFESSIONAL and Consultants for evaluating each such proposed substitute.

6.07 Concerning Subcontractors, Suppliers and Others

A. CONTRACTOR shall not employ or retain any Subcontractor, Supplier or other person or organization (including those acceptable to CITY as indicated in Paragraph 6.07 B), whether initially or as a substitute, against whom CITY has a reasonable objection, including but not limited to debarment by City or another governmental entity or decertification of the Subcontractor from the City's Minority and Women's Business Enterprise Program as a result of the Subcontractor's failure to comply with any of the requirements of the provisions of Chapter 3 of the City's Code as determined by the Director of the Civil Rights and Equal Opportunity Department. Contractor shall insert this provision in any subcontractor agreement associated with this Contract. CONTRACTOR shall not be required to employ any Subcontractor, Supplier or other person or organization to furnish or perform any of the Work against whom CONTRACTOR has reasonable objection. CONTRACTOR shall submit required information for all Subcontractors on Form 01290.09 - Subcontractor and Major Material Suppliers List, provided in these Contract Documents, prior to Subcontractor beginning Work at the Site.

B. The Supplementary Conditions require the identity of certain Subcontractors, Suppliers or other persons or organizations (including those who are to furnish the principal items of materials or equipment) to be submitted to CITY on or before the date specified in the Supplementary Conditions, for acceptance by CITY. If CONTRACTOR has submitted a list

thereof in accordance with the Supplementary Conditions, CITY may accept (either in writing or by failing to make written objection thereto by the date indicated for acceptance or objection in the Contract Documents) any such Subcontractor, Supplier or other person or organization so identified, or may reject same on the basis of reasonable objection after due investigation, in which case CONTRACTOR shall submit an acceptable replacement for the rejected Subcontractor, Supplier or other person or organization. The Contract Price will be adjusted by the difference in the cost occasioned by such substitution, and an appropriate Change Order will be issued or Written Amendment signed. No acceptance by CITY of any such Subcontractor, Supplier or other person or organization shall constitute a waiver of any right of CITY or DESIGN PROFESSIONAL to reject defective Work.

C. CONTRACTOR shall be fully responsible to CITY for all acts and omissions of the Subcontractors, Suppliers and other persons and organizations performing or furnishing any of the Work under a direct or indirect contract with CONTRACTOR just as CONTRACTOR is responsible for CONTRACTOR's own acts and omissions. Nothing in the Contract Documents shall create for the benefit of any such Subcontractor, Supplier or other person or organization any contractual relationship between CITY or DESIGN PROFESSIONAL and any such Subcontractor, Supplier or other person or organization, nor shall it create any obligation on the part of CITY or DESIGN PROFESSIONAL to pay or to see to the payment of any moneys due any such Subcontractor, Supplier or other person or organization except as may otherwise be required by Laws or Regulations.

D. CONTRACTOR shall be solely responsible for scheduling and coordinating the Work of Subcontractors, Suppliers and other persons and organizations performing or furnishing any of the Work under a direct or indirect contract with CONTRACTOR.

E. CONTRACTOR shall contractually require all Subcontractors, Suppliers and such other persons and organizations performing or furnishing any of the Work to communicate with CITY and DESIGN PROFESSIONAL through CONTRACTOR.

F. The divisions and sections of the Specifications and the identifications of any Drawings shall not control CONTRACTOR in dividing the Work among Subcontractors or Suppliers or delineating the Work to be performed by any specific trade.

G. All Work performed for CONTRACTOR by a Subcontractor or Supplier shall be pursuant to an appropriate written agreement between CONTRACTOR and the Subcontractor or Supplier that specifically binds the Subcontractor or Supplier to the applicable terms and conditions of the Contract Documents for the benefit of CITY. Whenever any such agreement is with a Subcontractor or Supplier who is listed as an additional insured on the property insurance provided in Paragraph 5.06, the agreement between the CONTRACTOR and the Subcontractor or Supplier will contain provisions whereby the Subcontractor or Supplier waives all rights against CITY, CONTRACTOR, DESIGN PROFESSIONAL, Consultants and all other additional insureds for all losses and damages caused by, arising out of or resulting from any perils, to the extent covered by such policies and any other property insurance applicable to the Work. If the insurers on any such policies require separate waiver forms to be signed by any Subcontractor or Supplier, CONTRACTOR will obtain the same.

H. Except as otherwise provided in this subsection H and in accordance with the provisions of subsection C hereof, the agreement between CONTRACTOR and the Subcontractor or Supplier referred to in subsection G, shall provide that the CONTRACTOR and the Subcontractor or Supplier agree not to request CITY or CITY's Representative to intervene in or facilitate the resolution of claims or contract disputes arising out of or related to the agreement between CONTRACTOR and the Subcontractor or Supplier. Furthermore, the Contracts between CONTRACTOR and Subcontractors or Suppliers shall provide that all unresolved claims and disputes between CONTRACTOR and the Subcontractor or Supplier that remain unresolved after thirty (30) calendar days from the notice of claim, shall be subject to mediation as a condition precedent to the institution of legal proceedings by either party. Any such mediation shall be conducted in accordance with the CITY's Code Section 3-467.

I. CONTRACTOR shall not insert any provision in any subcontractor agreement associated with this Contract that explicitly states or implies that the subcontractor shall only be paid for work performed if or when the general CONTRACTOR is paid by the CITY . Contractor's compliance with this provision is a material term of this Contract.

J. CONTRACTORS shall not deny any Subcontractor subcontracting opportunities solely because the Subcontractor is not a signatory to collective bargaining agreements with organized labor.

6.08 Patent Fees and Royalties

A. CONTRACTOR shall pay all license fees and royalties and assume all costs incident to the use in the performance of the Work or the incorporation into the Work of any invention, design, process, product or device which is the subject of patent rights or copyrights held by others. If a particular invention, design, process, product or device is specified in the Contract Documents for use in the performance of the Work, and if to the actual knowledge of CITY or DESIGN PROFESSIONAL its use is subject to patent rights or copyrights calling for the payment of any license fee or royalty to others, the existence of such rights shall be disclosed by CITY in the Contract Documents. To the fullest extent permitted by Laws or Regulations, CONTRACTOR shall defend, indemnify and hold harmless CITY, DESIGN PROFESSIONAL, Consultants and the officers, directors, employees, agents and other consultants of each and any of them from and against all claims, costs, losses and damages (including but not limited to all fees and charges of engineers, architects, attorneys, and other professionals and all court or arbitration or other dispute resolution costs) arising out of or resulting from any infringement of patent rights or copyrights incident to the use in the performance of the Work or resulting from the incorporation into the Work of any invention, design, process, product or device not specified in the Contract Documents.

6.09 Permits

A. Unless otherwise provided in the Supplementary Conditions, CONTRACTOR shall obtain and pay for all construction permits and licenses. CITY shall assist CONTRACTOR, when necessary, in obtaining such permits and licenses. CONTRACTOR shall pay all governmental charges and inspection fees necessary for the prosecution of the Work, which are applicable at the time of opening of Bids, or, if there are no Bids, on the Effective Date of the Contract. CONTRACTOR shall pay all charges of utility owners for connections to the Work.

B. CONTRACTOR, at its own expense, shall comply with all Federal, State and local laws and regulations, including, but not limited to the Missouri Clean Water Law (Chapter 644 RSMo) together with any accompanying regulation(s) contained in the Missouri Code of State Regulations (CSR Title 10), as well as any implementing permits, together with any CITY Provisions during the life of this Contract including but not limited to:

1. Approvals and permits as required for construction or land disturbance activities.
2. Compliance with the State of Missouri – Department of Natural Resources (“MDNR”) Missouri State Operating Permit (“Land Disturbance Permit”), MO-R100006 for all construction or land disturbance activity.
3. Development and implementation of a Storm Water Pollution Prevention Plan (SWPPP).
 - (a) Contractor shall not commence land disturbance activity until the initial SWPPP has been finalized.
 - (b) Preparation and submittal of all applications, documentation and exhibits required to obtain MDNR approvals for uninterrupted Work at the Site.
 - (c) Amending/Updating SWPPP.
 - (d) Site Inspections and submittal of Inspection Reports

(e) Proper Operation and Maintenance to achieve compliance with the terms of the Permit.

(f) Maintenance of required records in accordance with MDNR requirements and requirements included in Article 6 of these Contract Documents.

4. In addition to requirements of Article 6, Contractor shall also provide record access to Missouri Department of Natural Resources (MDNR).

5. Failure to control erosion and water pollution is a permit violation. CONTRACTOR shall have 24 hours after receiving notice of the violation to correct the problem. If the CONTRACTOR fails to correct the problem after the time prescribed, the City will hire a remediation expert to fix the problem. In such an event, the CONTRACTOR shall be liable to the City for the remediation costs plus a 10% mark-up of the total contract price. If the CONTRACTOR receives three (3) notices of violation of the erosion control plan and the City's MS4 permit, the Director may issue a stop work order and delay any payment until control measures are properly functioning and stream damage has been mitigated. In such an event, any delay to the project schedule will result in liquidated damages assessed against the CONTRACTOR.

6.10 Compliance with Laws and Regulations

A. CONTRACTOR shall comply with all federal, state and local laws, ordinances and regulations applicable to the work and this Contract. CONTRACTOR shall give all notices and comply with all Laws or Regulations applicable to furnishing and performing the Work. Except where otherwise expressly required by applicable Laws or Regulations, neither CITY nor DESIGN PROFESSIONAL shall be responsible for monitoring CONTRACTOR's compliance with any Laws or Regulations. The Laws or Regulations included in this Paragraph shall include, but not be limited to, those set forth in the Supplementary Conditions.

B. Failure to Comply. If CONTRACTOR performs any Work in violation of applicable Laws or Regulations, CONTRACTOR shall bear all claims, costs, losses and damages (including but not limited to all fees and charges of engineers, architects, attorneys, and other professionals and all court or arbitration or other dispute resolution costs) caused by, arising out of or resulting therefrom; however, it shall not be CONTRACTOR's primary responsibility to make certain that the Specifications and Drawings are in accordance with Laws or Regulations, but this shall not relieve CONTRACTOR of CONTRACTOR's obligations under Paragraph 3.03.

C. Conflicts of Interest. The provisions of City's Code Sections 2-2001 and 3-301, prohibiting City officers and employees from having a financial or personal interest in any contract with City, and Code Sections 3-307, and 3-309, imposing sanctions for violations, shall apply to this Contract. CONTRACTOR certifies that no officer or employee of City has, or will have, a direct or indirect financial or personal interest in this Contract, and that no officer or employee of City, or member of such officer's or employee's immediate family, either has negotiated, or has or will have an arrangement concerning employment to perform services on behalf of CONTRACTOR on this Contract.

D. Licenses and Permits. CONTRACTOR, at its own expense, shall secure or cause to be secured all licenses and permits from public or private sources necessary for the fulfillment of its obligations under this Contract. All references in this Contract to the "Code" shall mean City's Code of Ordinances, including any amendments thereto or re-codification thereof unless the context clearly indicates otherwise. CONTRACTOR shall obtain copies of all necessary licenses and permits from Subcontractors required for the Work before Subcontractors begin Work at the Site. CONTRACTOR shall retain such evidence in its files and make available to CITY within ten (10) days after CITY's written request.

E. Americans with Disabilities Act. CONTRACTOR agrees to comply, during the course of this Contract, with all provisions of Title II of the 2010 ADA Standards for Accessible Design as amended from time to time.

F. Affirmative Action. If the Contract Price exceeds \$300,000.00 and CONTRACTOR employs fifty (50) or more people, CONTRACTOR shall comply with City's Affirmative Action requirements in accordance with the provisions of Chapter 3 of City's Code, the rules and regulations relating to those sections, and any additions or amendments thereto. CONTRACTOR shall not discriminate against any employee or applicant for employment because of race, color, sex, religion, national origin or ancestry, disability, sexual orientation, gender identity or age in a manner prohibited by Chapter 3 of City's Code.

CONTRACTOR shall:

1. Submit, in print or electronic format, a copy of CONTRACTOR'S current certificate of compliance to the City's Civil Rights and Equal Opportunity Department (CREO) prior to receiving the first payment under the contract, unless a copy has already been submitted to CREO at any point within the previous two calendar years. If, and only if, CONTRACTOR does not possess a current certification of compliance, CONTRACTOR shall submit, in print or electronic format, a copy of its affirmative action program to CREO prior to receiving the first payment under the contract, unless a copy has already been submitted to CREO at any point within the previous two calendar years.

2. Require any Subcontractor awarded a subcontract exceeding \$300,000.00 to affirm that Subcontractor has an affirmative action program in place and will maintain the affirmative action program in place for the duration of the subcontract.

3. Obtain from any Subcontractor awarded a subcontract exceeding \$300,000.00 a copy of the Subcontractor's current certificate of compliance and tender a copy of the same, in print or electronic format, to CREO within thirty (30) days from the date the subcontract is executed. If, and only if, Subcontractor does not possess a current certificate of compliance, CONTRACTOR shall obtain a copy of the Subcontractor's affirmative action program and tender a copy of the same, in print or electronic format, to CREO within thirty (30) days from the date the subcontract is executed.

City has the right to take action as directed by City's Civil Rights and Equal Opportunity Department to enforce this provision. If CONTRACTOR fails, refuses or neglects to comply with the provisions of Chapter 3 of City's Code, then such failure shall be deemed a total breach of this Contract and this Contract may be terminated, canceled or suspended, in whole or in part, and CONTRACTOR may be declared ineligible for any further contracts funded by City for a period of one (1) year. This is a material term of this Contract.

G. Minority and Women Business Enterprises and Workforce. City is committed to ensuring that minorities and women participate to the maximum extent possible in the performance of City's construction contracts. If minority and women business enterprise (M/WBE) goals have been set for this Contract, CONTRACTOR agrees to comply with all requirements of City's Minority and Women's Business Enterprise Program as enacted in City's Code, Sections 3-421 through 3-469 and as hereinafter amended. CONTRACTOR shall meet or exceed both the MBE and WBE goals set forth in its Contractor Utilization Plan/Request for Waiver. If workforce utilization goals are applicable to this Contract, CONTRACTOR agrees to comply with all requirements of City's Construction Employment Program as enacted in City's Code, Sections 3-501 through 3-527 and as hereinafter amended. CONTRACTOR shall meet or exceed the construction employment goals unless the same shall have been waived in the manner provided by law. CONTRACTOR's compliance with this provision is a material part of this Contract.

H. Records.

1. For purposes of this section:

(a) "City" shall mean the City Auditor, the City's Internal Auditor, the City's Director of Civil Rights and Equal Opportunity, the City Manager, the City department administering this Contract and their delegates and agents.

(b) "Record" shall mean any document, book, paper, photograph, map, sound recordings or other material, regardless of physical form or characteristics, made or received in connection with this Contract and all Contract amendments and renewals.

2. CONTRACTOR shall maintain and retain all Records for a term of five (5) years that shall begin after the expiration or termination of this Contract and all Contract amendments. City shall have a right to examine or audit all Records and CONTRACTOR shall provide access to City of all records upon ten (10) days written notice from the City.

I. Prevailing Wage.

1. CONTRACTOR shall comply and require its Subcontractors to comply with;

a. sections 290.210 to 290.340, RSMO the State of Missouri Prevailing Wage Law (the "Law"); and

b. 8 CSR 30-3.010 to 8 CSR 30-3.060, the Prevailing Wage Law Rules (the "Rules"); and

c. the Annual Wage Order (Wage Order) issued by the State of Missouri's Department of Labor and Industrial Relations; and

d. any applicable Annual Incremental Wage Increase (Wage Increase) to the Annual Wage Order.

2. The Law, Rules, Annual Wage Order and any Wage Increase are incorporated into and made part hereof this Contract and shall be collectively referred to in this Section as the "Prevailing Wage Requirements."

3. CONTRACTOR shall pay and require its Subcontractors to pay to all workers performing work under this Contract not less than the prevailing hourly rate of wages for the class or type of work performed by the worker in accordance with the Law, Rules, Wage Order and any applicable Wage Increase. CONTRACTOR shall take whatever steps are necessary to insure that the prevailing hourly wage rates are paid and that all workers for CONTRACTOR and each of its Subcontractors are paid for the class or type of work performed by the worker in accordance with the Prevailing Wage Requirements. If CONTRACTOR shall fail to start to perform CONTRACTOR's obligations under the Contract Documents within sixty (60) days from the Effective Date of the Contract, CONTRACTOR and each of its subcontractors shall be obligated to pay all workers in accordance with any new Wage Order, as subsequently amended by any applicable Wage Increase, issued by the Department of Labor and Industrial Relations within the aforementioned sixty (60) day period. The new Wage Order and any applicable Wage Increase shall govern notwithstanding the fact that the Wage Order being replaced might be physically attached or incorporated in the Contract Documents.

4. Prior to each of its Subcontractors beginning Work on the Site, CONTRACTOR shall require each Subcontractor to complete CITY's Form 00490 entitled "Pre-contract Certification" that sets forth the Subcontractor's prevailing wage and tax compliance history for the two (2) years prior to the bid. CONTRACTOR shall retain one (1) year and make the Pre-contract Certifications available to CITY within five (5) days after written request.

5. CONTRACTOR shall:

a. Keep and require each of its Subcontractors engaged in the construction of public works in performance of the Contract to keep full and accurate records on City's "Daily Labor Force Report" Form indicating the worker's name, occupational title or classification group & skill and the workers' hours. City shall furnish blank copies of the Daily Labor Force Report Form to Contractor for its use and for distribution to Subcontractors. Contractor shall submit its and its Subcontractors Daily Labor Force Reports to City each day; and

b. Submit, and require each of its Subcontractors engaged in the construction of public works in performance of the Contract to submit electronically, in a format prescribed by the City, Certified Payroll Report Information indicating the worker's name, address, social security number, occupation(s), craft(s) of every worker employed in connection with the public work together with the number of hours worked by each worker and the actual wages paid in connection with the Project and other pertinent information as requested by the City; and

c. Submit, and require each of its Subcontractors engaged in the construction of public works in performance of the Contract to submit, electronically, in format prescribed by the City, a Payroll Certification. The Payroll Certification must be signed by the employee or agent who pays or supervises the payment of the workers employed under the Contract for the Contractor and each Subcontractor; and

d. The Daily Labor Force Report, documents used to compile information for the Certified Payroll Report, and Payroll Certification are collectively referred to in this Section as the "Records."

6. CONTRACTOR shall submit its and its Subcontractors Daily Labor Force Reports to CITY each day. CONTRACTOR shall make all of CONTRACTOR's and Subcontractors' Records open to inspection by any authorized representatives of OWNER and the Missouri Department of Labor and Industrial Relations at any reasonable time and as often as they may be necessary and such Records shall not be destroyed or removed from the State of Missouri for a period of one (1) year following the completion of the public work in connection with which the Records are made. CONTRACTOR shall have its and its Subcontractors Certified Payroll Reports and Payroll Certifications available at the CONTRACTOR's office and shall provide the Records to the City electronically at City's sole discretion. In addition, all Records shall be considered a public record and CONTRACTOR shall provide the Records to the CITY in the format required by the CITY within three (3) working days of any request by CITY at the CONTRACTOR's cost. CITY, in its sole discretion, may require CONTRACTOR to send any of the Records directly to the person who requested the Record at CONTRACTOR's expense.

7. CONTRACTOR shall post and keep posted a clearly legible statement of all prevailing hourly wage rates to be paid to all workers employed by CONTRACTOR and each of its Subcontractors in the performance of this Contract in a prominent and easily accessible place at the Site of the Work by all workers.

8. If the Contract Price exceeds \$250,000.00, CONTRACTOR shall and shall require each Subcontractor engaged in any construction of public works to have its name, acceptable abbreviation or recognizable logo and the name of the city and state of the mailing address of the principal office of the company, on each motor vehicle and motorized self-propelled piece of equipment which is used in connection with the Project during the time the CONTRACTOR or Subcontractor is engaged on the project. The sign shall be legible from a distance of twenty (20') feet, but the size of the lettering need not be larger than two (2") inches. In cases where equipment is leased or where affixing a legible sign to the equipment is impractical, the CONTRACTOR may place a temporary stationary sign, with the information required pursuant to this section, at the main entrance of the Project in place of affixing the required information on the equipment so long as such sign is not in violation of any state or federal statute, rule or regulation. Motor vehicles which are required to have similar information affixed thereto pursuant to requirements of a regulatory agency of the state or federal government are exempt from the provisions of this subsection.

9. CONTRACTOR must correct any errors in CONTRACTOR's or any Subcontractors' Records, or CONTRACTOR's or any Subcontractors' violations of the Law, Rules, Annual Wage Order and any Wage Increase within fourteen (14) calendar days after notice from CITY.

10. CONTRACTOR shall and shall require its Subcontractors to cooperate with the CITY and the Department of Labor and Industrial Relations in the enforcement of this Section, the Law, Rules, Annual Wage Order and any Wage Increase. Contractor shall and shall require its Subcontractors to permit CITY and the Department of Labor and Industrial Relations to interview any and all workers during working hours on the Project at CONTRACTOR's sole cost and expense.

11. CONTRACTOR shall file with CITY, upon completion of the Project and prior to final payment therefore, affidavits from CONTRACTOR and each of its Subcontractors, stating that each has fully complied with the provisions and requirements of the Missouri Prevailing Wage Law. CITY shall not make final payment until the affidavits, in proper form and order, from CONTRACTOR and each of its Subcontractors, are filed by CONTRACTOR.

12. CONTRACTOR shall forfeit as a statutory penalty to the CITY one hundred dollars (\$100.00) for each worker employed, for each calendar day, or portion thereof, such worker is paid less than the prevailing hourly rates for any work done under this Contract, by CONTRACTOR or by any of CONTRACTOR's Subcontractors. If CONTRACTOR or any of its Subcontractors have violated any section(s) of 290.210 to 290.340, RSMo, in the course of the execution of the Contract, CITY shall when making payments to the CONTRACTOR becoming due under this Contract, withhold and retain therefrom all sums and amounts due and owing as a result of any violation of sections 290.210 to 290.340, RSMo.

J. Prevailing Wage Damages. CONTRACTOR acknowledges and agrees that, based on the experience of CITY, violations of the Missouri Prevailing Wage Act, whether by CONTRACTOR or its Subcontractors, commonly result in additional costs to CITY. CONTRACTOR agrees that additional costs to CITY for any particular violation are difficult to establish and include but are not limited to: costs of construction delays, additional work for CITY, additional interest expenses, investigations, and the cost of establishing and maintaining a special division working under the City Manager to monitor prevailing wage compliance.

1. In the event of the failure by CONTRACTOR or any of its Subcontractors to pay wages as provided in the Missouri Prevailing Wage Act, CITY shall be entitled to deduct from the Contract Price, and shall retain as liquidated damages, one hundred dollars (\$100.00) per day, per worker who is paid less than the prevailing hourly rate of wages, to approximate the additional costs. The sum shall be deducted, paid or owed whether or not the Contract Times have expired.

2. CITY shall give written notice to CONTRACTOR setting forth the workers, who have been underpaid, the amount of the statutory penalty and the amount of the liquidated damages as provided for in this Subparagraph J. CONTRACTOR shall have fourteen (14) calendar days to respond, which time may be extended by CITY upon written request. If CONTRACTOR fails to respond within the specified time, the CITY's original notice shall be deemed final. If CONTRACTOR responds to CITY's notice, CITY will furnish CONTRACTOR a final decision in writing within five (5) days of completing any investigation.

K. Missouri Secretary of State Business Entity Registration. CONTRACTOR shall obtain from all Subcontractors for the Project, a copy of their current certificate of good standing or fictitious name registration from the Missouri Secretary of State before they begin work on the Site. CONTRACTOR shall retain such documents in its files and make available to CITY within ten (10) days after written request.

L. Tropical Hardwoods. The provisions of Code Section 2-1872, restricting the use of tropical hardwoods, shall apply to this Contract.

M. Preference for Missouri Products. Pursuant to Section 71.140 RSMo., preference shall be given to materials, products, supplies and all other articles produced, manufactured, made or grown within the State of Missouri.

N. Guidelines for Open Excavations.

1. CONTRACTOR shall restore required excavations to the level of the adjacent surfaces as soon as practicable. Unsupervised open excavations on public properties are discouraged at all times. If CONTRACTOR, in performance of the Work, makes or causes to be made any excavation in, upon, under, through or adjoining any street, sidewalk, alley, park, boulevard, parkway or any other public properties, and shall leave any part or portion thereof open, CONTRACTOR shall provide effective protection to the public.

2. CONTRACTOR shall protect and secure all excavations in roadways in compliance with existing federal, state and local codes and standards, including, but not limited to the most current edition of the Manual of Uniform Traffic Control Devices. CONTRACTOR shall protect and secure all unsupervised excavations not within roadways, either by covering or fencing.

a. Covering. A protective cover that can sustain the weight of persons or of objects that are placed upon it may be installed over an unsupervised excavation. The cover shall be secured to the ground to prevent movement. Protective covers shall have no opening(s) or protuberance(s) of sufficient size to cause a fall and/or injury. Advance warning devices shall be installed as necessary.

b. Fencing. Fencing to prevent entry may be installed surrounding an unsupervised excavation not protectively covered in its entirety. The fencing shall be a minimum of 42" in height. The fencing shall be constructed in such a manner that it is adequately secured and will remain upright at all times under normal Site conditions. All protective coverings and fences over and around excavations shall be inspected at least daily to assure integrity. Protective coverings and/or fences in heavily trafficked areas shall be inspected more often as necessary.

O. Notification of Utilities. CONTRACTOR shall adhere to the provisions of Sections 319.010 et seq., RSMo., which requires that a person or firm making an excavation in any public street, road or alley, right of way dedicated to public use, utility easement of record, or within any private street or private property do so only after giving notice to, and obtaining information from, owners of Underground Facilities. The 24-hour, toll-free accident prevention hotline number in Missouri is 1-800-344-7483 (1-800-Digrite).

P. Employee Eligibility Verification. CONTRACTOR shall adhere to the provisions of Sections 285.525 et seq., RSMo., which requires that for any contract exceeding five thousand dollars (\$5,000.00), CONTRACTOR shall execute and submit an affidavit, in a form prescribed by CITY, affirming that CONTRACTOR does not knowingly employ any person in connection with the contracted services who does not have the legal right or authorization under federal law to work in the United States as defined in 8 U.S.C. § 1324a(h)(3). CONTRACTOR shall attach to the affidavit documentation sufficient to establish CONTRACTOR'S enrollment and participation in an electronic verification of work program operated by the United States Department of Homeland Security (E-Verify) or an equivalent federal work authorization program operated by the United States Department of Homeland Security to verify information of newly hired employees, under the Immigration Reform and Control Act of 1986. CONTRACTOR may obtain additional information about E-Verify and enroll at <https://e-verify.uscis.gov/enroll/StartPage.aspx?JS=YES>. For those Contractors enrolled in E-Verify, the first and last pages of the E-Verify Memorandum of Understanding that CONTRACTOR will obtain upon successfully enrolling in the program shall constitute sufficient documentation for purposes of complying with this Section. CONTRACTOR shall submit the affidavit and attachments to CITY prior to execution of the Contract, or at any point during the term of the Contract if requested by City.

Q. OSHA 10-Hour Training Requirement. CONTRACTOR and any subcontractor working under this Contract shall require every employee on the Site to complete a ten-hour construction safety program which meets the requirements of Section 292.675, RSMo, except for those employees who shall have previously completed the required program and hold documentation to that effect. CONTRACTOR shall remove or require the removal of any

person from the Site who is subject to this requirement and who does not complete or is unable to produce documentation of their successful completion of the required program within the time limitations prescribed by Section 292.675, RSMo. CONTRACTOR shall forfeit the sum of two thousand five hundred dollars (\$2,500.00), in addition to one hundred dollars (\$100.00) per employee each calendar day, or portion thereof, the employee(s) shall continue to be employed without having completed the required program within the time limitations prescribed by Section 292.675, RSMo. CITY shall be entitled to withhold and retain any amounts due and owing hereunder when making payment to CONTRACTOR.

R. Clean Air Act and Clean Water Act. CONTRACTOR shall comply with requirements of the Clean Air Act (42 U.S.C. 7401 *et seq.*); Clean Water Act (33 U.S.C. 1251 *et seq.*), Missouri Clean Water Law (Chapter 644 RSMo), Code of Federal regulations (Title 40: Protection of Environment, Title 33: Navigation and Navigable Waters) and the rules of the Missouri Code of State Regulations (CSR Title 10).

S. Contract information Management System. If applicable, CONTRACTOR shall comply with CITY's Contract Information Management System requirements. CONTRACTOR shall use CITY's Internet web based Contract Information Management System/Project Management Communications Tool provided by CITY and protocols included in that software during the term of this Contract. CONTRACTOR shall maintain user applications to CITY's provided system for all personnel, subcontractors or suppliers as applicable and shall require subcontractors/subconsultants to maintain same.

T. Anti-Discrimination Against Israel. If this Contract exceeds \$100,000.00 and CONTRACTOR employs at least ten employees, pursuant to Section 34.600, RSMo., by executing this Contract, CONTRACTOR certifies it is not currently engaged in and shall not, for the duration of this contract, engage in a boycott of goods or services from the State of Israel; companies doing business in or with Israel or authorized by, licensed by, or organized under the laws of the State of Israel; or persons or entities doing business in the State of Israel.

U. Ban the Box in Hiring and Promotion

- a. Pursuant to Section 38-104, City Code Ordinances, CONTRACTOR shall not base a hiring or promotional decision on an applicant's criminal history or sentence related thereto, unless the employer can demonstrate that the employment-related decision was based on all information available including consideration of the frequency, recency and severity of a criminal record and that the record was reasonably related to the duties and responsibilities of the position.
- b. Notwithstanding subsection (a), CONTRACTOR may inquire about an applicant's criminal history after it has been determined that the individual is otherwise qualified for the position, and only after the applicant has been interviewed for the position. Any such inquiry may be made of all applicants who are within the final selection pool of candidates from which a job will be filled.
- c. This provision shall not apply to positions where employers are required to exclude applicants with certain criminal convictions from employment due to local, state or federal law or regulation.

V. Title VI of the Civil Rights Act of 1964

- a. Title VI of the Civil Rights Act of 1964 requires that no person in the United States shall, on the grounds of race, color, or national or origin (including limited English proficient individuals), be excluded from participation in, be denied the benefits of, or be subjected to discrimination under any program or activity receiving federal financial assistance. The City of Kansas City, Missouri requires compliance with the requirements of Title VI in all of its programs and activities regardless of the funding source.

- b. CONTRACTOR shall not discriminate on the grounds of race, color, or national or origin (including limited English proficient individuals).

W. Non-discrimination in Employment

CONTRACTOR shall not discriminate against any employee or candidate for employment on the basis of an individual's race, hair texture or hair style associated with an individual's race, color, sex, religion, national origin, or ancestry, disability, sexual orientation, gender identity or age in a manner prohibited by Chapter 38 of the City Code. CONTRACTOR shall not engage in any discrimination as prohibited by Chapter 3 of the City Code.

X. Quality Services Assurance Act

If this Contract exceeds \$160,000.00, CONTRACTOR certifies that CONTRACTOR will pay all employees who will work on this Contract in the city limits of Kansas City, Missouri at least \$15.00 per hour in compliance with the City's Quality Services Assurance Act, Section 3-66, Code of Ordinances unless City has granted CONTRACTOR an exemption pursuant to the Quality Services Assurance Act.

6.11 Taxes

A. CONTRACTOR shall pay all sales, consumer, use and other similar taxes required to be paid by CONTRACTOR in accordance with the Laws or Regulations of the place of the Project which are applicable during the performance of the Work.

B. Tax Compliance.

1. As a condition precedent to CITY making its first payment to CONTRACTOR under this Contract, CONTRACTOR shall furnish to CITY sufficient proof from City's Commissioner of Revenue, dated not more than one (1) year prior to the date provided to CITY, verifying that CONTRACTOR is in compliance with the license and tax ordinances administered by City's Revenue Division of the Finance Department.

2. As a condition precedent to Subcontractors performing any Work under this Contract, CONTRACTOR shall obtain from Subcontractor sufficient proof from City's Commissioner of Revenue, dated not more than one (1) year before the date Subcontractor begins Work, verifying that the Subcontractor is in compliance with the license and tax ordinances administered by City's Revenue Division of the Finance Department. CONTRACTOR shall retain such documentation in its files and make available to CITY within ten (10) days after a written request.

3. As a condition precedent to CITY making final payment under this Contract, if this Contract is longer than one (1) year and exceeds the dollar threshold established by ordinance and included in the Supplementary Conditions, CONTRACTOR shall furnish to CITY sufficient proof from City's Commissioner of Revenue, dated not more than one (1) year before the filing of a final Application for Payment, verifying that CONTRACTOR is in compliance with the license and tax ordinances administered by City's Revenue Division of the Finance Department.

4. If this Contract is longer than one (1) year and exceeds the dollar threshold established by ordinance and included in the Supplementary Conditions, CONTRACTOR shall obtain from Subcontractors sufficient proof from City's Commissioner of Revenue, dated not more than one (1) year before the date of CONTRACTOR's final payment to the Subcontractor, that the Subcontractor was or is in compliance with the license and tax ordinances administered by City's Revenue Division of the Finance Department. CONTRACTOR shall retain such documentation in its files and make available to CITY within ten (10) days after written request.

5. If, at the time of final payment to CONTRACTOR, CONTRACTOR is unable to obtain from all its Subcontractors, if any, and furnish to CITY sufficient proof from City's Commissioner of Revenue that all its Subcontractors are in compliance with the license and tax ordinances administered by City's Revenue Division of the Finance Department, CITY may approve final payment to CONTRACTOR if CITY determines that CONTRACTOR has made a good faith effort to furnish evidence or that there are other extenuating circumstances which make it impossible for CONTRACTOR to furnish sufficient proof.

C. Missouri Sales Tax Exemption. Pursuant to Section 144.062, RSMo, CITY is a Missouri exempt entity and tangible personal property to be incorporated or consumed in the construction of this Project may be purchased without sales tax. CITY shall furnish CONTRACTOR a Missouri Project Exemption Certificate for Sales Tax at the time of issuance of the Notice to Proceed.

6.12 Use of Site and Other Areas

A. CONTRACTOR shall confine construction equipment, the storage of materials and equipment, and the operations of workers to the Site and other areas identified in and permitted by the Contract Documents and other areas permitted by Laws or Regulations. CONTRACTOR shall not unreasonably encumber the Site and the other areas with construction equipment or other materials or equipment. CONTRACTOR shall assume full responsibility for any damage to the Site or the other areas, or to the owner or occupant thereof, or of any adjacent land or areas, resulting from the performance of the Work.

B. Should any claim be made by any such owner or occupant because of the performance of the Work, CONTRACTOR shall promptly settle with such other party by negotiation or otherwise resolve the claim by arbitration or other dispute resolution proceeding or at law. In case of a failure on the part of the CONTRACTOR to restore such property or to make good such damage or injuries, the CITY may, upon forty-eight (48) hours written notice to the CONTRACTOR, repair, rebuild or otherwise restore such property as the CITY may deem necessary, and the cost thereof will be deducted from any moneys due or which may become due the CONTRACTOR under this Contract.

C. CONTRACTOR shall, to the fullest extent permitted by Laws or Regulations, defend, indemnify and hold harmless CITY, DESIGN PROFESSIONAL, Consultants and the officers, directors, employees, agents and other consultants of each and any of them from and against all claims, costs, losses and damages (including but not limited to all fees and charges of engineers, architects, attorneys, and other professionals and all court or arbitration or other dispute resolution costs) arising out of or resulting from any claim or action, legal or equitable, brought by any such owner or occupant against CITY, DESIGN PROFESSIONAL or any other party indemnified hereunder to the extent caused by or based upon CONTRACTOR's performance of the Work.

D. During the progress of the Work, CONTRACTOR shall keep the Site and the other areas free from accumulations of waste materials, rubbish and other debris resulting from the Work. At the completion of the Work CONTRACTOR shall remove all waste materials, rubbish and debris from Site and other areas as well as all tools, appliances, construction equipment and machinery and surplus materials. CONTRACTOR shall leave the Site clean and ready for utilization or occupancy by CITY at Substantial Completion of the Work. CONTRACTOR shall restore to all property not designated for alteration by the Contract Documents to its pre-Work condition.

E. CONTRACTOR shall not load nor permit any part of any structure to be loaded in any manner that will endanger the structure, nor shall CONTRACTOR subject any part of the Work or adjacent property to stresses or pressures that will endanger it.

6.13 Record Documents

A. CONTRACTOR shall maintain in a safe place at the Site one record copy of all Drawings, Specifications, Addenda, the Contract, Written Amendments, Change Orders, Work

Change Directives, and written interpretations and clarifications in good order and annotated to show all changes made during construction. These record documents, together with all approved Samples and a counterpart of all approved Shop Drawings, will be available to CITY and DESIGN PROFESSIONAL for reference. Upon completion of the Work, these record documents, Samples and Shop Drawings will be delivered to DESIGN PROFESSIONAL for CITY.

6.14 Safety and Protection

A. CONTRACTOR shall be solely responsible for initiating, maintaining and supervising all safety precautions and programs in connection with the Work. CONTRACTOR shall comply with all applicable Laws or Regulations relating to the safety of persons or property to protect them from damage, injury or loss; and shall erect and maintain all necessary safeguards for safety and protection. CONTRACTOR shall deliver to CITY a copy of CONTRACTOR'S Health and Safety Plan as provided in the Notice of Intent to Contract.

B. CONTRACTOR shall notify owners of adjacent property and of Underground Facilities and other utility owners when prosecution of the Work may affect them, and shall cooperate with them in the protection, removal, relocation and replacement of their property. All damage, injury or loss to any property referred to in Paragraph 6.14 B.2 or 6.14 B.3 caused, directly or indirectly, in whole or in part, by CONTRACTOR, any Subcontractor, Supplier or any other person or organization directly or indirectly employed by any of them to perform or furnish any of the Work or anyone for whose acts any of them may be liable, shall be remedied by CONTRACTOR (except damage or loss attributable to the fault of Drawings or Specifications or to the acts or omissions of CITY, DESIGN PROFESSIONAL, Consultant, or anyone employed by any of them or anyone for whose acts any of them may be liable, and not attributable, directly or indirectly, in whole or in part, to the fault or negligence of CONTRACTOR, Subcontractor, Supplier or other person or organization directly or indirectly employed by any of them). CONTRACTOR's duties and responsibilities for safety and for protection of the Work shall continue until such time as all the Work is completed and DESIGN PROFESSIONAL has issued a notice to CONTRACTOR in accordance with Paragraph 14.07 that the Work is acceptable (except as otherwise expressly provided in connection with Substantial Completion). CONTRACTOR shall take all necessary precautions for the safety of, and shall provide the necessary protection to prevent damage, injury or loss to:

1. all persons on the Site or who may be affected by the Work;
2. all the Work and materials and equipment to be incorporated therein, whether in storage on or off the Site; and
3. other property at the Site or adjacent thereto, including trees, shrubs, lawns, walks, pavements, roadways, structures, utilities and Underground Facilities not designated for removal, relocation or replacement in the course of the Work.

6.15 Safety Representative

A. In accordance with OSHA standards, CONTRACTOR shall designate a qualified and experienced safety representative whose duties and responsibilities shall be the prevention of accidents and the maintaining and supervising of safety precautions and programs. CONTRACTOR's safety representative shall remain at the Site whenever there is Work in progress and shall immediately notify CITY of any emergencies or accidents occurring at the Site

6.16 Hazard Communication Programs

A. CONTRACTOR shall be responsible for coordinating any exchange of material safety data sheets or other hazard communication information required to be made available to or exchanged between or among employers at the Site in accordance with Laws or Regulations.

6.17 Emergencies

A. In emergencies affecting the safety or protection of persons or the Work or property at the Site or adjacent thereto, CONTRACTOR, without special instruction or authorization from CITY or DESIGN PROFESSIONAL, is obligated to act to prevent threatened damage, injury or loss. CONTRACTOR shall give CITY and DESIGN PROFESSIONAL prompt written notice if CONTRACTOR believes that any significant changes in the Work or variations from the Contract Documents have been caused thereby or are required as a result thereof. If CITY determines that a change in the Contract Documents is required because of the action taken by CONTRACTOR in response to an emergency, a Work Change Directive or Change Order will be issued.

B. A change in the Contract Documents pursuant to Paragraph 6.15 A will not be an automatic authorization of, nor a condition precedent to, entitlement to adjustment in the Contract Price or Contract Times. If CITY and CONTRACTOR are unable to agree on entitlement to, or magnitude of, an equitable adjustment in the Contract Price or Contract Times, a Claim may be made therefore as provided in Article 16. However, OWNER, DESIGN PROFESSIONAL and Consultants shall not be liable to CONTRACTOR for any costs, losses or damages (including but not limited to all fees and charges of engineers, architects, attorneys, and other professionals and all other dispute resolution costs) sustained by CONTRACTOR on or in connection with any other project or anticipated project.

6.18 Shop Drawings and Samples

A. CONTRACTOR shall submit Shop Drawings to DESIGN PROFESSIONAL for review and approval in accordance with the accepted schedule of Shop Drawings and Sample submittals (see Paragraph 2.07). All submittals shall be identified as DESIGN PROFESSIONAL may require and in the number of copies specified in the General Requirements. The data shown on the Shop Drawings shall be complete with respect to quantities, dimensions, specified performance and design criteria, materials and similar data to show DESIGN PROFESSIONAL the services, materials and equipment CONTRACTOR proposes to provide and to enable DESIGN PROFESSIONAL to review the information for the limited purposes required by Paragraph 6.18 D.

B. CONTRACTOR shall also submit Samples to DESIGN PROFESSIONAL for review and approval in accordance with said accepted schedule of Shop Drawings and Sample submittals. Each Sample shall be identified clearly as to material, Supplier, pertinent data such as catalog numbers and the use for which intended and otherwise as DESIGN PROFESSIONAL may require to enable DESIGN PROFESSIONAL to review the submittal for the limited purposes required by Paragraph 6.18 D. The numbers of each Sample to be submitted will be as specified in the Specifications.

C. Submittal Procedures:

1. Before submitting each Shop Drawing or Sample, CONTRACTOR shall have determined and verified:

a. all field measurements, quantities, dimensions, specified performance criteria, installation requirements, materials, catalog numbers and similar information with respect thereto;

b. all materials with respect to intended use, fabrication, shipping, handling, storage, assembly and installation pertaining to the performance of the Work;

c. all information relative to means, methods, techniques, sequences and procedures of construction and safety precautions and programs incident thereto; and

d. CONTRACTOR shall also have reviewed and coordinated each Shop Drawing or Sample with other Shop Drawings and Samples and with the requirements of the Work and the Contract Documents.

2. Each submittal shall bear a stamp or specific written indication that CONTRACTOR has satisfied CONTRACTOR's obligations under the Contract Documents with respect to CONTRACTOR's review and approval of that submittal.

3. At the time of each submission, CONTRACTOR shall give DESIGN PROFESSIONAL specific written notice of such variations, if any, that the Shop Drawing or Sample submitted may have from the requirements of the Contract Documents, the notice to be in a written communication separate from the submittal, and, in addition, shall cause a specific notation to be made on each Shop Drawing and Sample submitted to DESIGN PROFESSIONAL for review and approval of each such variation.

D. DESIGN PROFESSIONAL's Review:

1. DESIGN PROFESSIONAL will review and approve Shop Drawings and Samples in accordance with the schedule of Shop Drawings and Sample submittals accepted by DESIGN PROFESSIONAL as required by Paragraph 2.06. DESIGN PROFESSIONAL's review and approval will be only to determine if the items covered by the submittals will, after installation or incorporation into the Work, conform to the information given in the Contract Documents and be compatible with the design concept of the completed Project as a functioning whole as indicated by the Contract Documents.

2. DESIGN PROFESSIONAL's review and approval will not extend to means, methods, techniques, sequences or procedures of construction (except where a particular means, method, technique, sequence or procedure of construction is specifically and expressly called for by the Contract Documents) or to safety precautions or programs incident thereto. The review and approval of a separate item as such will not indicate approval of the assembly in which the item functions.

3. DESIGN PROFESSIONAL's review and approval of Shop Drawings or Samples shall not relieve CONTRACTOR from responsibility for any variation from the requirements of the Contract Documents unless CONTRACTOR has in writing called DESIGN PROFESSIONAL's attention to each such variation at the time of submission as required by Paragraph 6.18 C.3, and DESIGN PROFESSIONAL has given written approval of each such variation by specific written notation thereof incorporated into or accompanying the Shop Drawing or Sample approval; nor will any approval by DESIGN PROFESSIONAL relieve CONTRACTOR from responsibility for complying with the requirements of Paragraph 6.18 C.1.

E. Where a Shop Drawing or Sample is required by the Contract Documents or the schedule of Shop Drawings and Sample submissions accepted by DESIGN PROFESSIONAL as required by Paragraph 2.06, any related Work performed prior to DESIGN PROFESSIONAL's review and approval of the pertinent submittal will be at the sole expense and responsibility of CONTRACTOR.

F. CONTRACTOR shall make corrections required by DESIGN PROFESSIONAL and shall return the required number of corrected copies of Shop Drawings and submit as required new Samples for review and approval. CONTRACTOR shall direct specific attention in writing to revisions other than the corrections called for by DESIGN PROFESSIONAL on previous submittals.

6.19 Continuing the Work

A. CONTRACTOR shall carry on the Work and adhere to the progress schedule during all disputes or disagreements with CITY. No Work shall be delayed or postponed pending resolution of any disputes or disagreements, except as permitted by Paragraph 15.04 or as CITY and CONTRACTOR may otherwise agree in writing.

6.20 CONTRACTOR's General Warranty and Guarantee

A. CONTRACTOR warrants and guarantees to CITY, DESIGN PROFESSIONAL and Consultants that all Work will be in accordance with the Contract Documents and will not be

defective. CONTRACTOR's warranty and guarantee hereunder excludes defects or damage caused by:

1. abuse, modification or improper maintenance or operation by persons other than CONTRACTOR, Subcontractors, Suppliers or any other individual or entity for whom CONTRACTOR is responsible; or
2. normal wear and tear under normal usage.

B. CONTRACTOR's obligation to perform and complete the Work in accordance with the Contract Documents shall be absolute. None of the following will constitute an acceptance of Work that is not in accordance with the Contract Documents or a release of CONTRACTOR's obligation to perform the Work in accordance with the Contract Documents:

1. observations by DESIGN PROFESSIONAL;
2. recommendation of any progress or final payment by DESIGN PROFESSIONAL;
3. the issuance of a certificate of Substantial Completion or any payment related thereto by CITY to CONTRACTOR;
4. use or occupancy of the Work or any part thereof by OWNER;
5. any review and approval of a Shop Drawing or Sample submittal or the issuance of a notice of acceptability by DESIGN PROFESSIONAL;
6. any inspection, test or approval by others; or
7. any correction of defective Work by CITY.

C. Nonconforming Work is rejected unless expressly accepted in writing by the CITY's Representative.

ARTICLE 7 OTHER WORK

7.01 Related Work at Site

A. CITY may perform other work related to the Project at the Site by CITY's own forces, or let other direct contracts therefore, or have other work performed by utility owners. If such other work is to be performed and such fact was not noted in the Contract Documents, then:

1. Written notice thereof will be given to CONTRACTOR prior to starting any such other work, and
2. CONTRACTOR may make a Claim therefore as provided in Article 16 if CONTRACTOR believes that such performance involves additional expense to CONTRACTOR or requires additional time and the parties are unable to agree as to the amount or extent thereof.

B. CONTRACTOR shall afford each other contractor who is a party to such a direct contract, and each utility owner (and CITY, if CITY is performing the additional work with CITY's employees) proper and safe access to the Site and a reasonable opportunity for the introduction and storage of materials and equipment and the execution of such other work and shall properly connect and coordinate the Work with theirs. Unless otherwise provided in the Contract Documents, CONTRACTOR shall do all cutting, fitting and patching of the Work that may be required to properly connect or otherwise make its several parts come together and properly integrate with such other work. CONTRACTOR shall not endanger any work of others by cutting, excavating or otherwise altering their work and will only cut or alter their work with the written consent of CITY and the others whose work will be affected. The duties and responsibilities of CONTRACTOR under this Paragraph are for the benefit of such utility owners and other contractors to the extent that there are comparable provisions for the benefit of CONTRACTOR in said direct contracts between CITY and such utility owners and other contractors.

C. If the proper execution or results of any part of CONTRACTOR's Work depends upon work performed by others under this Article 7, CONTRACTOR shall inspect such other work and promptly report to CITY and DESIGN PROFESSIONAL in writing any delays, defects or deficiencies in such other work that render it unavailable or unsuitable for the proper execution or results of CONTRACTOR's Work. CONTRACTOR's failure to report same will constitute an acceptance of such other work as fit and proper for integration with CONTRACTOR's Work, except for latent or non-apparent defects and deficiencies in such other work.

7.02 Coordination

A. If CITY contracts with others for the performance of other work on the Project at the Site, the following will be set forth in Supplementary Conditions:

1. the person, firm or corporation who will have authority and responsibility for coordination of the activities among the various prime contractors will be identified;
2. the specific matters to be covered by such authority and responsibility will be itemized; and
3. the extent of such authority and responsibilities will be provided.

B. Unless otherwise provided in the Supplementary Conditions, CITY shall have sole authority and responsibility in respect of such coordination.

ARTICLE 8 CITY'S RESPONSIBILITIES

8.01 Communications to CONTRACTOR

A. Except as otherwise provided in these General Conditions, CITY shall issue all communications to CONTRACTOR.

8.02 Replacement of DESIGN PROFESSIONAL

A. In case of termination of the employment of DESIGN PROFESSIONAL, CITY shall appoint a DESIGN PROFESSIONAL whose status under the Contract Documents shall be that of the former DESIGN PROFESSIONAL.

8.03 Furnish Data and Prompt Payment

A. CITY shall promptly furnish the data required of OWNER under the Contract Documents and shall make payments to CONTRACTOR when they are due.

8.04 Lands and Easements; Reports and Tests

A. CITY's duties in respect of providing lands and easements and providing engineering surveys to establish reference points are set forth in Paragraphs 4.01 and 4.05. Paragraph 4.02 refers to CITY's duty to identify and make available to CONTRACTOR copies of reports of explorations and tests of subsurface conditions at the Site and drawings of physical conditions in existing structures at or contiguous to the Site that have been utilized by DESIGN PROFESSIONAL in preparing the Contract Documents.

8.05 Insurance

A. CITY's responsibilities, if any, for purchasing and maintaining liability and property insurance are set forth in Article 5 and the Supplementary Conditions.

8.06 Change Orders

A. CITY is obligated to execute Change Orders as indicated in Paragraph 10.03.

8.07 Inspections, Tests and Approvals

A. CITY's responsibility for certain inspections, tests and approvals is set forth in Paragraph 13.02 F.

8.08 Limitations on CITY's Responsibilities

A. The CITY shall not supervise, direct or have control or authority over, nor be responsible for, CONTRACTOR's means, methods, techniques, sequences or procedures of construction, or the safety precautions and programs incident thereto, or for any failure of CONTRACTOR to comply with Laws or Regulations applicable to the furnishing or performance of the Work. CITY will not be responsible for CONTRACTOR's failure to perform or furnish the Work in accordance with the Contract Documents.

8.09 Undisclosed Hazardous Environmental Condition

A. CITY's responsibility for an undisclosed Hazardous Environmental Condition uncovered or revealed at the Site is set forth in Paragraph 4.06.

8.10 Evidence of Financial Arrangements

A. CITY will furnish CONTRACTOR reasonable evidence that financial arrangements have been made to satisfy OWNER's obligations under the Contract.

8.11 CITY's Representative

A. CITY will provide a representative during the construction period. The duties, responsibilities and the limitations of authority of the CITY "'s Representative during construction are set forth in the Contract Documents.

8.12 Visits to Site

A. CITY's Representative will make visits to the Site at intervals appropriate to the various stages of construction as CITY's Representative deems necessary in order to observe the progress that has been made and the quality of the various aspects of CONTRACTOR's executed Work. Based on information obtained during such visits and observations, CITY's Representative will endeavor to determine, in general, if the Work is proceeding in accordance with the Contract Documents. CITY's Representative will not be required to make exhaustive or continuous on-Site inspections to check the quality or quantity of the Work.

ARTICLE 9 DESIGN PROFESSIONAL's STATUS DURING CONSTRUCTION

9.01 General Scope of DESIGN PROFESSIONAL's Duties

A. DESIGN PROFESSIONAL's efforts will be directed toward providing for CITY a greater degree of confidence that the completed Work will conform generally to the Contract Documents. On the basis of visits to the Site and on-Site observations, DESIGN PROFESSIONAL will keep CITY informed of the progress of the Work and will endeavor to guard CITY against defective Work. DESIGN PROFESSIONAL's visits to the Site and on-Site observations are subject to all the limitations on DESIGN PROFESSIONAL's authority and responsibility set forth in Paragraph 9.08.

9.02 Resident Project Representative

A. If CITY and DESIGN PROFESSIONAL agree, DESIGN PROFESSIONAL will furnish a resident Project representative to assist DESIGN PROFESSIONAL in providing more extensive observation of the Work. The responsibilities, authority and limitations thereon of any such resident Project representative and assistants will be as provided in Paragraph 9.08 and in the Supplementary Conditions.

9.03 Clarifications and Interpretations

A. DESIGN PROFESSIONAL will issue with reasonable promptness written clarifications or interpretations (which may be in the form of Drawings) of the requirements of the Drawings and Specifications prepared by the DESIGN PROFESSIONAL as DESIGN PROFESSIONAL may determine necessary, which shall be consistent with the intent of and reasonably inferable from the Contract Documents. Such written clarifications and interpretations will be binding on CITY and CONTRACTOR. If CITY or CONTRACTOR believes that a written clarification or

interpretation justifies an adjustment in the Contract Price pursuant to Article 11 and/ or the Contract Times pursuant to Article 12 and the parties are unable to agree to the amount or extent thereof, if any, a Claim may be made therefore as provided in Article 16.

9.04 Rejecting Defective Work

A. DESIGN PROFESSIONAL will have authority to disapprove or reject Work which DESIGN PROFESSIONAL believes to be defective, that DESIGN PROFESSIONAL believes will not produce a completed Project that conforms to the Contract Documents, or that will prejudice the integrity of the design concept of the completed Project as a functioning whole as indicated by the Contract Documents. DESIGN PROFESSIONAL will also have authority to require special inspection or testing of the Work as provided in Paragraph 13.04 B, whether or not the Work is fabricated, installed or completed.

9.05 Shop Drawings, Change Orders and Payments

A. In connection with DESIGN PROFESSIONAL's authority as to Shop Drawings and Samples, see Paragraph 6.18.

B. In connection with DESIGN PROFESSIONAL's authority as to Change Orders, see Article 10.

C. In connection with DESIGN PROFESSIONAL's authority as to Applications for Payment, see Article 14.

9.06 Determinations for Unit Prices

A. DESIGN PROFESSIONAL will initially determine the actual quantities and classifications of Unit Price Work performed by CONTRACTOR. DESIGN PROFESSIONAL will review with CONTRACTOR the DESIGN PROFESSIONAL's preliminary determinations on such matters before rendering a written opinion thereon (by recommendation of an Application for Payment or otherwise to the CITY). CITY reserves the right to make a final determination of the actual quantities and classifications of Unit Price Work in reviewing an Application for Payment. Within ten (10) days after the date of receipt of any such decision, CONTRACTOR may deliver to CITY and to DESIGN PROFESSIONAL written notice of intention to appeal CITY's decision pursuant to Article 16.

9.07 Decisions on Requirements of Contract Documents and Acceptability of Work

A. DESIGN PROFESSIONAL will be the initial interpreter of the requirements of the Drawings and Specifications prepared by DESIGN PROFESSIONAL and judge of the acceptability of the Work thereunder.

B. When functioning as interpreter and judge under this Paragraph 9.07, DESIGN PROFESSIONAL will not show partiality to OWNER or CONTRACTOR.

C. Claims, disputes and other matters relating to the acceptability of the Work, quantities and classifications of Unit Price Work, or the interpretation of the requirements of the Contract Documents pertaining to the performance and furnishing of the Work will be referred initially to CITY's Representative in writing with a request for a formal decision in accordance with Article 16.

9.08 Limitations on DESIGN PROFESSIONAL's Authority and Responsibilities

A. Neither DESIGN PROFESSIONAL's authority or responsibility under this Article 9 or under any other provision of the Contract Documents nor any decision made by DESIGN PROFESSIONAL in good faith either to exercise or not exercise such authority or responsibility or the undertaking, exercise or performance of any authority or responsibility by DESIGN PROFESSIONAL shall create, impose or give rise to any duty owed by DESIGN PROFESSIONAL to CONTRACTOR, any Subcontractor, any Supplier, any other person or organization, or to any surety for or employee or agent of any of them.

B. DESIGN PROFESSIONAL will not supervise, direct, control or have authority over or be responsible for CONTRACTOR's means, methods, techniques, sequences or procedures of construction, or the safety precautions and programs incident thereto, or for any failure of CONTRACTOR to comply with Laws or Regulations applicable to the furnishing or performance of the Work. DESIGN PROFESSIONAL will not be responsible for CONTRACTOR's failure to perform or furnish the Work in accordance with the Contract Documents.

C. DESIGN PROFESSIONAL will not be responsible for the acts or omissions of CONTRACTOR or of any Subcontractor, any Supplier, or of any other person or organization performing or furnishing any of the Work.

D. DESIGN PROFESSIONAL's review of the final Application for Payment and accompanying documentation, and all maintenance and operating instructions, schedules, guarantees, Bonds and certificates of inspection, tests and approvals and other documentation required to be delivered by Paragraph 14.07 will only be to determine generally that their content complies with the requirements of, and in the case of certificates of inspections, tests and approvals, that the results certified indicate compliance with, the Contract Documents.

E. The limitations upon authority and responsibility set forth in this Paragraph 9.08 shall also apply to DESIGN PROFESSIONAL's Consultants, resident Project representative and assistants as identified in the Supplementary Conditions.

ARTICLE 10 CHANGES IN THE WORK

10.01 Authorized Changes in the Work

A. Without invalidating the Contract and without notice to any surety, CITY may, at any time or from time to time, order additions, deletions or revisions in the Work. Such additions, deletions or revisions will be authorized by a Written Amendment, a Change Order, or a Work Change Directive. Upon receipt of any such document, CONTRACTOR shall promptly proceed with the Work involved that will be performed under the applicable conditions of the Contract Documents (except as otherwise specifically provided).

B. If CITY and CONTRACTOR are unable to agree on entitlement to, or on the amount or extent, if any, of an adjustment in the Contract Price pursuant to Article 11 or an adjustment of the Contract Times pursuant to Article 12 or both that should be allowed as a result of a Work Change Directive, a Claim may be made therefore as provided in Article 16.

10.02 Unauthorized Changes in the Work

A. CONTRACTOR shall not be entitled to an increase in the Contract Price or an extension of the Contract Times with respect to any work performed that is not required by the Contract Documents as amended, modified or supplemented as provided in Paragraph 3.04, except in the case of an emergency as provided in Paragraph 6.17 or in the case of uncovering Work as provided in Paragraph 13.04.

10.03 Signing of Change Orders

A. CITY and CONTRACTOR, and DESIGN PROFESSIONAL shall sign appropriate Change Orders covering:

1. changes in the Work which are:
 - a. ordered by CITY pursuant to Paragraph 10.01 A; or
 - b. required because of acceptance of defective Work under Paragraph 13.08 or correcting defective Work under Paragraph 13.09; or
 - c. agreed to by the parties;
2. changes in the Contract Price or Contract Times or both which are agreed to by the parties, including any undisputed sum or amount of time for Work actually performed in accordance with a Work Change Directive; and

3. changes in the Contract Price or Contract Times or both which embody the substance of any written decision recommended by DESIGN PROFESSIONAL and approved by CITY pursuant to Paragraph 9.06, provided that, in lieu of signing any such Change Order, an appeal may be taken from any such decision in accordance with the provisions of the Contract Documents and applicable Laws or Regulations, but during any such appeal, CONTRACTOR shall carry on the Work and adhere to the progress schedule as provided in Paragraph 6.19.

10.04 Notification to Surety

A. If notice of any change affecting the general scope of the Work or the provisions of the Contract Documents (including, but not limited to, Contract Price or Contract Times or both) is required by the provisions of any Bond to be given to a surety, the giving of any such notice will be CONTRACTOR's responsibility, and the amount of each applicable Bond will be adjusted accordingly.

ARTICLE 11 CHANGE OF CONTRACT PRICE

11.01 Change of Contract Price

A. The Contract Price constitutes the total compensation (subject to authorized adjustments) payable to CONTRACTOR for performing the Work. All duties, responsibilities and obligations assigned to or undertaken by CONTRACTOR shall be at CONTRACTOR's expense without change in the Contract Price.

B. The Contract Price may only be changed by a Change Order. Any request for an adjustment in the Contract Price shall be based on written notice delivered within fourteen (14) calendar days after occurrence of the event giving rise to the request or within fourteen (14) calendar days after first recognition of the conditions giving rise to the request. Prior notice is not required for requests or claims relating to an emergency endangering life or property as described in Paragraph 6.16. Thereafter, the CONTRACTOR shall submit written documentation of its request, including appropriate supporting documentation, within ten (10) calendar days after giving notice, unless the CITY grants an extension based on good cause shown by the CONTRACTOR that such additional time is warranted.

C. The value of any Work covered by a Change Order or of any request for an adjustment in the Contract Price will be determined as follows:

1. where the Work involved is covered by Unit Prices contained in the Contract Documents, by application of such Unit Prices to the quantities of the items involved (subject to the provisions of Paragraph 11.04); or

2. where the Work involved is not covered by Unit Prices contained in the Contract Documents, by a mutually agreed lump sum; or

3. where the Work involved is not covered by Unit Prices contained in the Contract Documents and agreement to a lump sum is not reached under Paragraph 11.01 C.2, on the basis of the Cost of the Work (determined as provided in Paragraphs 11.02 A and B) plus a CONTRACTOR's fee for overhead and profit (determined as provided in Paragraph 11.01 D).

D. The CONTRACTOR's fee allowed to CONTRACTOR for overhead and profit shall be determined as follows:

1. a mutually acceptable fixed fee; or

2. if a fixed fee is not agreed upon, then a fee based on the following percentages of the various portions of the Cost of the Work:

a. for costs incurred under Paragraphs 11.02 A.1 and 11.02 A.2, the CONTRACTOR's fee shall be ten percent (10%);

b. for costs incurred under Paragraph 11.02 A.3, the CONTRACTOR's fee shall be five percent (5%);

c. where one or more tiers of subcontracts are on the basis of the Cost of the Work plus a fee and no fixed fee is agreed upon, the intent of Paragraphs 11.01 D.2 and 11.02 A.1 through A.3 is that the Subcontractor who actually performs or furnishes the Work, at whatever tier, will be paid a fee of ten percent (10%) of the costs incurred by such Subcontractor under Paragraphs 11.02 A.1 and 11.02 A.2 and that any higher tier Subcontractor and CONTRACTOR will each be paid a fee of five percent (5%) of the amount paid to the next lower tier Subcontractor;

d. no fee shall be payable on the basis of costs itemized under Paragraphs 11.02 A.4, 11.02 A.5 and 11.02 B;

e. the amount of credit to be allowed by CONTRACTOR to CITY for any change which results in a net decrease in cost will be the amount of the actual net decrease in costs plus a deduction in CONTRACTOR's fee by an amount equal to five percent (5%) of such net decrease; and

f. when both additions and credits are involved in any one change, the adjustment in CONTRACTOR's fee shall be computed on the basis of the net change in accordance with Paragraphs 11.01 D.2.a through 11.01 D.2.e, inclusive.

E. Whenever the Cost of the Work is to be determined pursuant to Paragraphs 11.02 A and B, CONTRACTOR shall establish and maintain records thereof in accordance with generally accepted accounting practices and submit in form acceptable to CITY an itemized cost breakdown together with supporting data.

11.02 Cost of the Work

A. The term "Cost of the Work" means the sum of all costs necessarily incurred and paid by CONTRACTOR in the proper performance of the Work. When the value of any Work covered by a Change Order or when a request for an adjustment in Contract Price is determined on the basis of Cost of the Work, the costs to be reimbursed to CONTRACTOR will be only those additional or incremental costs required because of the change in the Work or because of the event giving rise to the request. Except as otherwise agreed to in writing by CITY, costs covered by Change Orders or requests shall be in amounts no higher than those prevailing in the locality of the Project, shall include only the following items and shall not include any costs itemized in 11.02 B:

1. Payroll costs for employees in the direct employ of CONTRACTOR in the performance of the Work, using occupational titles and job classifications agreed upon by CITY and CONTRACTOR. Such employees shall include, without limitation, job Site superintendents, foremen and other personnel employed full time at the Site. Payroll costs for employees not employed full time on the Work shall be apportioned on the basis of their time spent on the Work. Payroll costs shall include, but not be limited to, salaries and wages plus the cost of fringe benefits which shall include social security contributions, unemployment, excise and payroll taxes, workers' compensation, health and retirement benefits, bonuses, sick leave, vacation and holiday pay applicable thereto. The expenses of performing the Work after regular working hours, on Saturdays, Sundays or legal holidays, shall be included in the above to the extent authorized by OWNER.

2. Cost of all materials and equipment furnished and incorporated into the Work, including costs of transportation and storage thereof, and Suppliers' field services required in connection therewith. All cash discounts shall accrue to CONTRACTOR unless CITY deposits funds with CONTRACTOR with which to make payments, in which case the cash discounts shall accrue to CITY. All trade discounts, rebates and refunds and returns from sale of surplus materials and equipment shall accrue to CITY, and CONTRACTOR shall make provisions so that they may be obtained.

3. Payments made by CONTRACTOR to Subcontractors for Work performed or furnished by Subcontractors. If required by CITY, CONTRACTOR shall obtain competitive bids from Subcontractors acceptable to OWNER and CONTRACTOR and shall deliver such bids to CITY who will then determine, with the advice of DESIGN PROFESSIONAL, which bids, if any, will be accepted. If any subcontract provides that the Subcontractor is to be paid on the basis of the Cost of the Work plus a fee, the Subcontractor's Cost of the Work and fee shall be determined in the same manner as CONTRACTOR's Cost of the Work and fee as provided in Paragraphs 11.01 D and E and 11.02 A and B. All subcontracts shall be subject to the other provisions of the Contract Documents insofar as applicable.

4. Costs of special consultants (including but not limited to engineers, architects, testing laboratories, surveyors, attorneys and accountants) employed for services specifically related to the Work when such services are approved in advance by CITY in writing.

5. Other costs including the following:

a. The proportion of necessary transportation, travel and subsistence expenses of CONTRACTOR's employees incurred in discharge of duties connected with the Work.

b. Cost, including transportation and maintenance, of all materials, supplies, equipment, machinery, appliances, office and temporary facilities at the Site and hand tools not owned by the workers, which are consumed in the performance of the Work, and cost, less market value of such items used but not consumed which remain the property of CONTRACTOR.

c. Rentals of all construction equipment and machinery and the parts thereof whether rented from CONTRACTOR or others in accordance with rental agreements approved by CITY with the advice of DESIGN PROFESSIONAL, and the costs of transportation, loading, unloading, installation, assembly, dismantling and removal thereof, all in accordance with the terms of said rental agreements. The rental of any such equipment, machinery or parts shall cease when the use thereof is no longer necessary for the Work.

d. Applicable sales, consumer, use or similar taxes related to the Work, and for which CONTRACTOR is liable, imposed by Laws or Regulations.

e. Deposits lost for causes other than negligence of CONTRACTOR, any Subcontractor or anyone directly or indirectly employed by any of them or for whose acts any of them may be liable, and royalty payments and fees for permits and licenses required to perform the Work.

f. Losses and damages (and related expenses) caused by damage to the Work, not compensated by insurance or otherwise, sustained by CONTRACTOR in connection with the performance and furnishing of the Work (except losses and damages within the deductible amounts of property insurance established by CITY in accordance with Article 5), provided they have resulted from causes other than the negligence of CONTRACTOR, any Subcontractor, or anyone directly or indirectly employed by any of them or for whose acts any of them may be liable. Such losses shall include settlements made with the written consent and approval of CITY. No such losses, damages and expenses shall be included in the Cost of the Work for the purpose of determining CONTRACTOR's fee. If, however, any such loss or damage requires reconstruction and CONTRACTOR is placed in charge thereof, CONTRACTOR shall be paid for those services a fee proportionate to that stated in Paragraph 11.01 D.2.

g. The cost of utilities, fuel and sanitary facilities at the Site.

h. Minor expenses such as telegrams, long distance telephone calls, telephone service at the Site, expressage and similar petty cash items in connection with the Work.

i. Cost of premiums for additional or increased Bonds, or for insurance required because of approved changes in the Work.

B. Costs excluded: The term “Cost of the Work” shall not include any of the following:

1. Payroll costs and other compensation of CONTRACTOR’s officers, executives, principals (of partnership and sole proprietorships), general managers, engineers, architects, estimators, attorneys, auditors, accountants, purchasing and contracting agents, expeditors, timekeepers, clerks and other personnel employed by CONTRACTOR whether at the Site or in CONTRACTOR’s principal or a branch office for general administration of the Work (if not specifically included in the agreed upon occupational titles and job classifications referred to in Paragraph 11.02 A.1 or specifically covered by Paragraph 11.02 A.4), all of which are to be considered administrative costs covered by the CONTRACTOR’s fee.

2. Expenses of CONTRACTOR’s principal and branch offices other than CONTRACTOR’s office at the Site.

3. Any part of CONTRACTOR’s capital expenses, including interest on CONTRACTOR’s capital employed for the Work and charges against CONTRACTOR for delinquent payments.

4. Costs due to the negligence of CONTRACTOR, any Subcontractor, or anyone directly or indirectly employed by any of them or for whose acts any of them may be liable, including but not limited to, the correction of defective Work, disposal of materials, or equipment wrongly supplied, and making good any damage to property.

5. Other overhead or general expense costs of any kind and the costs of any item not specifically and expressly included in Paragraph 11.02 A.

11.03 Cash Allowances

A. It is understood that CONTRACTOR has included in the Contract Price all allowances so named in the Contract Documents and shall cause the Work so covered to be furnished and performed for such sums as may be acceptable to CITY. CONTRACTOR agrees that:

1. the allowances include the cost to CONTRACTOR (less any applicable trade discounts) of materials and equipment required by the allowances to be delivered at the Site, and all applicable taxes; and

2. CONTRACTOR’s costs for unloading and handling on the Site, labor, installation costs, overhead, profit and other expenses contemplated for the allowances have been included in the Contract Price and not in the allowances, and no demand for additional payment on account of any of the foregoing will be valid.

B. Prior to final payment, an appropriate Change Order will be issued by CITY to reflect actual amounts due CONTRACTOR on account of Work covered by allowances, and the Contract Price shall be correspondingly adjusted.

11.04 Unit Price Work

A. Where the Contract Documents provide that all or part of the Work is to be Unit Price Work, initially the Contract Price will be deemed to include for all Unit Price Work an amount equal to the sum of the established unit price for each separately identified item of Unit Price Work times the estimated quantity of each item as indicated in the Contract. The estimated quantities of items of Unit Price Work are not guaranteed and are solely for the purpose of comparison of Bids and determining an initial Contract Price. Determinations of the actual quantities and classifications of Unit Price Work performed by CONTRACTOR will be made in accordance with Paragraph 9.06.

B. Each unit price will be deemed to include an amount considered by CONTRACTOR to be adequate to cover CONTRACTOR’s overhead and profit for each separately identified item.

C. CITY or CONTRACTOR may negotiate an adjustment of the price per unit of Unit Price Work stated in the Contract if:

1. the quantity of any item of Unit Price Work performed by CONTRACTOR differs by twenty percent (20%) or more from the estimated quantity of such item indicated in the Contract; and

2. there is no corresponding adjustment with respect to any other item of Work; and

3. CONTRACTOR believes that CONTRACTOR is entitled to an increase in Contract Price as a result of having incurred additional expense or CITY believes that CITY is entitled to a decrease in Contract Price.

11.05 Dispute Resolution

A. If CITY and CONTRACTOR are unable to agree on entitlement to, or magnitude of, an equitable adjustment in the Contract Price in accordance with Article 11 within fourteen (14) calendar days from the receipt of supporting documentation of the request pursuant to 11.01.B., unless the CITY grants an extension based on good cause shown by the CONTRACTOR that such additional time is warranted, then a Claim for such adjustment may be made pursuant to Article 16.

ARTICLE 12 CONTRACT TIMES

12.01 Time of the Essence

A. All times stated in the Contract Documents are of the essence of the Contract.

12.02 Change of Contract Times

A. The Contract Times (or Milestones) may only be changed by a Change Order. Any request for an adjustment in the Contract Times shall be based on written notice delivered within fourteen (14) calendar days after occurrence of the event giving rise to the request or within fourteen (14) calendar days after first recognition of the conditions giving rise to the request. Thereafter, the CONTRACTOR shall submit written documentation of its requests, including appropriate supporting documentation, within ten (10) days after giving notice, unless the CITY grants an extension based on good cause shown by the CONTRACTOR that such additional time is warranted.

12.03 Proof Required To Justify an Extension of Time For Excusable and Compensable Delays

A. In support of any request for an extension of the Contract Times pursuant to this Article, CONTRACTOR must demonstrate to the reasonable satisfaction of the CITY that the critical path of the approved baseline project schedule was delayed. CONTRACTOR shall be entitled to an increase in contract time for the number of days that the critical path was delayed solely as a result of the compensable or excusable event. A compensable or excusable event includes, but is not limited to:

1. unreasonable delay of issuance of Notice to Proceed by CITY;
2. CITY's unreasonable delay of delivery furnished materials, equipment, or work;
3. unreasonable delay responding to shop drawings and submittals;
4. CITY's unreasonable delay in issuing a Change Order;
5. an order by the CITY to stop the Work where the CONTRACTOR was not at fault; and
6. other reasonable grounds as determined by the City in its sole discretion.

B. CONTRACTOR shall compare the critical path of the approved baseline project schedule to the actual critical path of the Work, identifying the specific impact of the compensable or excusable event.

C. CONTRACTOR shall submit to the CITY a written time impact analysis illustrating the influence of each compensable or excusable event on the date of Substantial Completion. The

time impact analysis shall demonstrate the time impact based on the date of the delay in time and the event time computations or all affected activities.

D. If the critical path of the Work is delayed by "Force Majeure", the CONTRACTOR shall be entitled only to an extension of the Contract Times for the number of days of delay to the critical path. For purposes of this paragraph, "Force Majeure" shall mean fire, tornado, flood, earthquake, war, act of terrorism, civil disturbance, or labor strikes away from the project site.

E. Extensions of contract time pursuant to the this section will be granted only to the extent that the time adjustments exceed the total float time available when the event causing the delay occurred.

12.04 Delays Within CONTRACTOR's Control

A. The Contract Times (or Milestones) will not be extended due to delays within the control of CONTRACTOR. Delays attributable to and within the control of a Subcontractor or Supplier shall be deemed to be delays within the control of CONTRACTOR.

12.05 Delays Beyond the CITY's and CONTRACTOR's Control

A. Where CONTRACTOR is prevented from completing any part of the Work within the Contract Times (or Milestones) due to delay beyond the control of both CITY and CONTRACTOR, an extension of the Contract Times (or Milestones) in an amount equal to the time lost due to such delay shall be CONTRACTOR's sole and exclusive remedy for such delay.

12.06 Delay Damages

A. In no event shall CITY be liable to CONTRACTOR, any Subcontractor, any Supplier, any other person or organization, or to any surety for or employee or agent of any of them, for damages arising out of or resulting from:

1. delays caused by or within the control of CONTRACTOR, or
2. delays beyond the control of CITY or CONTRACTOR including but not limited to fires, floods, epidemics, abnormal weather conditions, acts of God or acts or neglect by utility owners or other contractors performing other work as contemplated by Article 7.

B. Nothing in this Paragraph 12.06 bars a change in Contract Price pursuant to this Article 12 to compensate CONTRACTOR due to delay, interference, or disruption directly attributable to actions or inaction of CITY, DESIGN PROFESSIONAL, Consultant or anyone for whom CITY, DESIGN PROFESSIONAL or Consultant is responsible.

12.07 Dispute Resolution

A. If CITY and CONTRACTOR are unable to agree on entitlement to, or magnitude of, an equitable adjustment in the Contract Time in accordance with Article 12 within fourteen (14) calendar days from the receipt of supporting documentation of the request pursuant to 12.02, unless the CITY grants an extension based on good cause shown by the CONTRACTOR that such additional time is warranted, then a Claim for such adjustment may be made pursuant to Article 16.

ARTICLE 13 TESTS AND INSPECTIONS; CORRECTION, REMOVAL OR ACCEPTANCE OF DEFECTIVE WORK

13.01 Access to Work

A. CITY, DESIGN PROFESSIONAL, Consultants, other representatives and personnel of CITY, independent testing laboratories and governmental agencies with jurisdictional interests will have access to the Site and Work at reasonable times for their observation, inspecting and testing. CONTRACTOR shall provide them proper and safe conditions for such access and advise them of CONTRACTOR's Site safety procedures and programs so that they may comply therewith as applicable.

13.02 Tests and Inspections

A. CONTRACTOR shall give DESIGN PROFESSIONAL and CITY's Representative timely notice of readiness of the Work for all required inspections, tests or approvals, and shall cooperate with inspection and testing personnel to facilitate required inspections or tests.

B. If any Work (or the work of others at the Site) that is to be inspected, tested or approved is covered by CONTRACTOR without written approval required by Paragraphs 13.02 D or 13.02 E, it must, if requested by CITY's Representative, be uncovered for observation.

C. Uncovering Work as provided in Paragraph 13.02 B, shall be at CONTRACTOR's expense unless CONTRACTOR has given DESIGN PROFESSIONAL and CITY's Representative timely notice of CONTRACTOR's intention to cover the same and DESIGN PROFESSIONAL and CITY's Representative have not acted with reasonable promptness in response to such notice.

D. If Laws or Regulations of any public body (including City) having jurisdiction require any Work (or part thereof) specifically to be inspected, tested or approved by an employee or other representative of such public body, CONTRACTOR shall assume full responsibility for arranging and obtaining such inspections, tests or approvals, pay all costs in connection therewith, and furnish DESIGN PROFESSIONAL and CITY's Representative the required certificates of inspection or approval.

E. CONTRACTOR shall be responsible for arranging and obtaining and shall pay all costs in connection with any inspections, tests or approvals required for CITY's and DESIGN PROFESSIONAL's acceptance of materials or equipment to be incorporated into the Work, or acceptance of materials, mix designs, or equipment submitted for approval prior to CONTRACTOR's purchase thereof for incorporation into the Work. Such inspections, tests, or approvals shall be performed by organizations acceptable to CITY and DESIGN PROFESSIONAL.

F. CITY shall employ and pay for the services of an independent testing laboratory to perform all inspections, tests, or approvals required by the Contract Documents except:

1. for inspections, tests or approvals covered by Paragraph 13.02 D and E;
2. that costs incurred in connection with tests or inspections conducted pursuant to Paragraph 13.04 B shall be paid as provided in said Paragraph 13.04 B; and
3. as otherwise specifically provided in the Contract Documents.

13.03 Notice of Defects

A. Prompt notice of all defective Work of which either CITY or DESIGN PROFESSIONAL has actual knowledge will be given to CONTRACTOR. Defective Work may be rejected, corrected or accepted as provided in this Article 13.

13.04 Uncovering Work

A. If any Work (or the work of others at the Site) is covered contrary to the written request of DESIGN PROFESSIONAL or CITY's Representative, it must, if requested by CITY's Representative, be uncovered for DESIGN PROFESSIONAL's or CITY's Representative's observation and replaced at CONTRACTOR's expense.

B. If CITY considers it necessary or advisable that covered Work be observed by DESIGN PROFESSIONAL or CITY's Representative or be inspected or tested by others, CONTRACTOR, at CITY's request, shall uncover, expose or otherwise make available for observation, inspection or testing as may be required, that portion of the Work in question, furnishing all necessary labor, material and equipment. If it is found that such Work is defective, CONTRACTOR shall pay all costs, losses and damages (including but not limited to all fees and charges of engineers, architects, attorneys, and other professionals and all court or arbitration or other dispute resolution costs) caused by, arising out of or resulting from such uncovering, exposure, observation, inspection and testing and of satisfactory replacement or reconstruction

(including but not limited to all costs of repair or replacement of work of others); and CITY shall be entitled to an appropriate decrease in the Contract Price. If the parties are unable to agree as to the amount thereof, CITY may make a Claim therefore as provided in Article 16. If, however, such Work is not found to be defective, CONTRACTOR shall be allowed an increase in the Contract Price or an extension of the Contract Times (or Milestones), or both, directly attributable to such uncovering, exposure, observation, inspection, testing, replacement and reconstruction. If the parties are unable to agree as to the amount or extent thereof, CONTRACTOR may make a Claim therefore as provided in Article 16.

13.05 CITY May Stop the Work

A. If the Work is defective, or CONTRACTOR fails to supply sufficient skilled workers or suitable materials or equipment, or fails to furnish or perform the Work in such a way that the completed Work will conform to the Contract Documents, CITY may order CONTRACTOR to stop the Work, or any portion thereof, until the cause for such order has been eliminated; however, this right of CITY to stop the Work shall not give rise to any duty on the part of CITY to exercise this right for the benefit of CONTRACTOR, any Subcontractor, Supplier, other individual or entity or any surety or employee or agent of any of them.

13.06 Correction or Removal of Defective Work

A. If required by CITY, CONTRACTOR shall promptly, as directed, either correct all defective Work, whether or not fabricated, installed or completed, or, if the Work has been rejected by either DESIGN PROFESSIONAL or CITY's Representative, remove it and replace it with Work that is not defective. CONTRACTOR shall pay all costs, losses and damages (including but not limited to all fees and charges of engineers, architects, attorneys, and other professionals and all court or arbitration or other dispute resolution costs) caused by or resulting from such correction or removal (including but not limited to all costs of repair or replacement of work of others).

13.07 Correction Period

A. If within one (1) year after the date of Substantial Completion, or such longer period of time as may be prescribed by Laws or Regulations, by the terms of any applicable special guarantee required by the Contract Documents, or by any specific provision of the Contract Documents, any Work is found to be defective, or if the repair of any damages to the land or areas made available for CONTRACTOR's use by CITY or permitted by Laws and Regulations as contemplated in Paragraph 6.10 is found to be defective, CONTRACTOR shall promptly, without cost to CITY and in accordance with CITY's written instructions:

1. correct the repair of damages to such land or areas; or
2. correct such defective Work, or if it has been rejected by CITY, remove it from the Site and replace it with Work that is not defective; and
3. satisfactorily correct or remove and replace any damage to other Work or to the work of others or damage to other lands or areas resulting therefrom. If CONTRACTOR does not promptly comply with the terms of such instructions, or in the event of an emergency where delay by CONTRACTOR would cause serious risk of loss or damage, CITY may have the defective Work corrected or the rejected Work removed and replaced, and all costs, losses and damages (including but not limited to all fees and charges of engineers, architects, attorneys, and other professionals and all court or arbitration or other dispute resolution costs) caused by or resulting from such removal and replacement (including but not limited to all costs of repair or replacement of work of others) will be paid by CONTRACTOR.

B. In special circumstances where a particular item of equipment is placed in continuous service before Substantial Completion of all the Work, the correction period for that item may start to run from an earlier date if so provided in the Specifications or by Written Amendment.

C. Where defective Work (and damage to other Work resulting therefrom) has been corrected or removed and replaced under this Paragraph 13.07, the correction period hereunder

with respect to such Work will be extended for an additional period of one (1) year, or such longer period of time as may be prescribed within Paragraph 13.07 A, after such correction or removal and replacement has been satisfactorily completed.

D. CONTRACTOR's obligations under this Paragraph 13.07 are in addition to any other obligation or warranty. The provisions of this Paragraph 13.07 shall not be construed as a substitute for or waiver of the provisions of any applicable statute of limitation or repose.

13.08 Acceptance of Defective Work

A. If, instead of requiring correction or removal and replacement of defective Work, CITY prefers to accept it, CITY may do so. CONTRACTOR shall pay all costs, losses and damages (including but not limited to all fees and charges of engineers, architects, attorneys, and other professionals and all court or arbitration or other dispute resolution costs) attributable to CITY's evaluation of and determination to accept such defective Work and shall pay OWNER for the diminished value of the Work. If any such acceptance occurs prior to DESIGN PROFESSIONAL's recommendation of final payment, a Change Order will be issued incorporating the necessary revisions into the Contract Documents with respect to the Work and, due to the diminished value of the Work, CITY shall be entitled to an appropriate decrease in the Contract Price. If the parties are unable to agree as to the amount thereof, CITY may make a Claim therefore as provided in Article 16. If the acceptance of defective Work occurs after such recommendation, an appropriate amount shall be paid by CONTRACTOR to CITY.

13.09 CITY May Correct Defective Work

A. If CONTRACTOR fails within a reasonable time after written notice from DESIGN PROFESSIONAL or CITY's Representative to correct defective Work or to remove and replace rejected Work as required by CITY in accordance with Paragraph 13.06, or if CONTRACTOR fails to perform the Work in accordance with the Contract Documents, or if CONTRACTOR fails to comply with any other provision of the Contract Documents, CITY may, after seven (7) days written notice to CONTRACTOR, correct and remedy any such deficiency.

B. CITY shall proceed expeditiously when exercising the rights and remedies under this Paragraph 13.09. In connection with such corrective and remedial action, CITY may exclude CONTRACTOR from all or part of the Site; take possession of all or part of the Work and suspend CONTRACTOR's services related thereto; take possession of CONTRACTOR's tools, appliances, construction equipment and machinery at the Site; and incorporate into the Work all materials and equipment stored at the Site or for which CITY has paid CONTRACTOR but which are stored elsewhere. CONTRACTOR shall allow CITY, CITY's Representative, agents and employees, CITY's other contractors, DESIGN PROFESSIONAL and Consultants access to the Site to enable CITY to exercise the rights and remedies under this Paragraph 13.09.

C. All costs, losses and damages (including but not limited to all fees and charges of engineers, architects, attorneys, and other professionals and all court or arbitration or other dispute resolution costs) incurred or sustained by CITY in exercising such rights and remedies will be charged against CONTRACTOR and a Change Order will be issued incorporating the necessary revisions into the Contract Documents with respect to the Work; and CITY shall be entitled to an appropriate decrease in the Contract Price. If CITY and CONTRACTOR are unable to agree as to the amount thereof, CITY may make a Claim therefore as provided in Article 16. Such Claims for costs, losses and damages will include but not be limited to all costs of repair or replacement of work of others destroyed or damaged by correction, removal and replacement of CONTRACTOR's defective or rejected Work.

D. CONTRACTOR shall not be allowed an extension of the Contract Times (or Milestones) because of any delay in the performance of the Work attributable to the exercise by CITY of CITY's rights and remedies under Paragraphs 13.06 and 13.09.

ARTICLE 14 PAYMENTS TO CONTRACTOR AND COMPLETION

14.01 Schedule of Values

A. 01290.02 Schedule of Values established as provided in Article 2 will serve as the basis for progress payments and will be incorporated into form 01290.01 Application for Payment acceptable to DESIGN PROFESSIONAL and CITY. Progress payments for Unit Price Work will be based on the number of units completed.

14.02 Application for Progress Payments

A. Application for Payment

1. At least twenty (20) days before the date stipulated in the Supplementary Conditions for each progress payment (but not more often than once a month), CONTRACTOR shall submit to DESIGN PROFESSIONAL for review an Application for Payment filled out and signed by CONTRACTOR covering the Work completed as of the date of the Application and accompanied by such supporting documentation as is required by the Contract Documents. If payment is requested on the basis of materials and equipment not incorporated into the Work but delivered and suitably stored at the Site or at another location agreed to in writing, the Application for Payment shall also be accompanied by a bill of sale, paid invoice or other documentation warranting that CITY has received the materials and equipment free and clear of all Liens and evidence that the materials and equipment are covered by appropriate property insurance and other arrangements to protect CITY's interest therein, all of which will be subject to CITY's approval.

2. Beginning with the second Application for Payment, each Application shall include:

a. an affidavit of CONTRACTOR stating that all previous progress payments received for the Work have been applied to discharge CONTRACTOR's legitimate obligations associated with prior Applications for Payment, and

b. a copy of the most recent 00485.01 M/WBE Monthly Utilization Report CONTRACTOR has submitted to the CITY's Civil Rights and Equal Opportunity Department.

c. a copy of the most recent 00485.02 Project Workforce Monthly Report and 00485.03 Company-Wide Workforce Monthly Report CONTRACTOR has submitted to the OWNER's Civil Rights and Equal Opportunity Department.

d. an update to the approved schedule pursuant to paragraphs 6.04 and 6.05.

3. The amount of retainage with respect to progress payments will be stated in the Supplementary Conditions.

B. Review of Applications

1. DESIGN PROFESSIONAL will, within ten (10) days after receipt of each Application for Payment, either indicate in writing a recommendation of payment and present the Application to CITY, or return the Application to CONTRACTOR indicating in writing DESIGN PROFESSIONAL's reasons for refusing to recommend payment. In the latter case, CONTRACTOR shall make the necessary corrections and resubmit the Application.

a. After presentation of the Application for Payment to CITY, and if CITY's Representative agrees with DESIGN PROFESSIONAL's recommendation, the amount recommended will (subject to the provisions of Paragraph 14.02 B.4) become due and will be paid by CITY to CONTRACTOR, subject to the provisions of Laws or Regulations.

b. No payment shall be approved until the CONTRACTOR has submitted with the Application accompanying documentation as required by the Contract Documents, including, but not limited to, the documentation required by paragraphs 6.04 and 6.05.

2. DESIGN PROFESSIONAL's recommendation of any payment requested in an Application for Payment will constitute a representation by DESIGN PROFESSIONAL to CITY, based on DESIGN PROFESSIONAL's observations of the executed Work as an experienced and qualified DESIGN PROFESSIONAL and on DESIGN PROFESSIONAL's

review of the Application for Payment and the accompanying data and schedules, that to the best of DESIGN PROFESSIONAL's knowledge, information and belief:

- a. the Work has progressed to the point indicated;
- b. the quality of the Work is generally in accordance with the Contract Documents (subject to an evaluation of the Work as a functioning whole prior to or upon Substantial Completion, to the results of any subsequent tests called for in the Contract Documents, to a final determination of quantities and classifications for Unit Price Work under Paragraph 9.06, and to any other qualifications stated in the recommendation); and
- c. the conditions precedent to CONTRACTOR being entitled to such payment appear to have been fulfilled in so far as it is DESIGN PROFESSIONAL's responsibility to observe the Work.

3. DESIGN PROFESSIONAL's recommendation of any payment, including final payment, shall not mean that DESIGN PROFESSIONAL is responsible for CONTRACTOR's means, methods, techniques, sequence or procedures of construction, safety precautions and programs incident thereto, or any failure of CONTRACTOR to comply with Laws or Regulations applicable to the furnishing or performance of Work.

4. DESIGN PROFESSIONAL may refuse to recommend the whole or any part of any payment if, in DESIGN PROFESSIONAL's opinion, it would be incorrect to make the representations to CITY referred to in Paragraph 14.02 B.2. DESIGN PROFESSIONAL may also refuse to recommend any such payment or, because of subsequently discovered evidence or the results of subsequent inspections or tests, nullify any such payment previously recommended, to such extent as may be necessary in DESIGN PROFESSIONAL's opinion to protect CITY from loss because:

- a. the Work is defective, or completed Work has been damaged requiring correction or replacement;
- b. the Contract Price has been reduced by Written Amendment or Change Orders;
- c. CITY has been required to correct defective Work or complete Work in accordance with Paragraph 13.09; or
- d. DESIGN PROFESSIONAL has actual knowledge of the occurrence of any of the events enumerated in Paragraph 15.02.

C. Reduction in Payment

1. CITY may refuse to make payment of the full amount recommended by DESIGN PROFESSIONAL because:

- a. Claims have been made by third parties against CITY on account of CONTRACTOR's performance or furnishing of the Work; or
- b. Claims have been made by CITY against CONTRACTOR in connection with the Work, except where CONTRACTOR has delivered a specific Bond satisfactory to CITY to secure the satisfaction and discharge of such Claims;
- c. there are other items entitling CITY to a set-off against the amount recommended; or
- d. CITY has actual knowledge of the occurrence of any of the events enumerated in Paragraphs 14.02 B.4.a through c or 15.02 A.1 through 4; but CITY must give CONTRACTOR written notice (with a copy to DESIGN PROFESSIONAL) stating the reasons for such action and promptly pay CONTRACTOR the amount so withheld, or any adjustment thereto agreed to by CITY and CONTRACTOR, when CONTRACTOR corrects to CITY's satisfaction the reasons for such action; or
- e. CITY has made a different determination of the actual quantities and classifications of Unit Price Work.

14.03 CONTRACTOR's Warranty of Title

A. CONTRACTOR warrants and guarantees that title to all Work, materials and equipment covered by any Application for Payment, whether incorporated into the Project or not, will pass to CITY no later than the time of payment, free and clear of all Liens.

14.04 Substantial Completion

A. When CONTRACTOR considers the entire Work ready for its intended use CONTRACTOR shall notify CITY and DESIGN PROFESSIONAL in writing that the entire Work is substantially complete (except for items specifically listed by CONTRACTOR as incomplete) and request that CITY issue a certificate of Substantial Completion. Within a reasonable time thereafter, CITY, together with CONTRACTOR and DESIGN PROFESSIONAL, shall make an inspection of the Work to determine the status of completion. If DESIGN PROFESSIONAL does not consider the Work substantially complete, DESIGN PROFESSIONAL will notify CONTRACTOR and CITY in writing giving the reasons therefore. If DESIGN PROFESSIONAL considers the Work substantially complete, DESIGN PROFESSIONAL will prepare and deliver to CITY a recommended certificate of Substantial Completion that shall establish the date of Substantial Completion. There shall be attached to the certificate a tentative list of items to be completed or corrected before final payment. CITY shall have seven (7) days after receipt of the recommended certificate during which to make written objection to DESIGN PROFESSIONAL as to any provisions of the certificate or attached list. At the time of delivery of the recommended certificate of Substantial Completion, DESIGN PROFESSIONAL will deliver to CITY and CONTRACTOR a written recommendation as to division of responsibilities pending final payment between CITY and CONTRACTOR with respect to security, operation, safety, protection of the Work, maintenance, heat, utilities, insurance and warranties and guarantees.

B. CITY shall have the right to exclude CONTRACTOR from the Site after the date of Substantial Completion, but CITY shall allow CONTRACTOR reasonable access to complete or correct items on the tentative list.

14.05 Partial Utilization

A. Use by CITY at CITY's option of any substantially completed part of the Work which has specifically been identified in the Contract Documents, or which CITY, DESIGN PROFESSIONAL and CONTRACTOR agree constitutes a separately functioning and usable part of the Work that can be used by CITY for its intended purpose without significant interference with CONTRACTOR's performance of the remainder of the Work, may be accomplished prior to Substantial Completion of all the Work subject to the following:

1. CITY at any time may request CONTRACTOR in writing to permit CITY to use any such part of the Work which CITY believes to be ready for its intended use and substantially complete. If CONTRACTOR agrees that such part of the Work is substantially complete, CONTRACTOR will certify to CITY and DESIGN PROFESSIONAL that such part of the Work is substantially complete and request CITY to issue a certificate of Substantial Completion for that part of the Work. CONTRACTOR at any time may notify CITY and DESIGN PROFESSIONAL in writing that CONTRACTOR considers any such part of the Work ready for its intended use and substantially complete and request CITY to issue a certificate of Substantial Completion for that part of the Work. Within a reasonable time after either such request, CITY, together with CONTRACTOR and DESIGN PROFESSIONAL, shall make an inspection of that part of the Work to determine its status of completion. If DESIGN PROFESSIONAL does not consider that part of the Work to be substantially complete, DESIGN PROFESSIONAL will notify CITY and CONTRACTOR in writing, giving the reasons therefore. If DESIGN PROFESSIONAL considers that part of the Work to be substantially complete, the provisions of Paragraph 14.04 will apply with respect to certification of Substantial Completion of that part of the Work and the division of responsibility in respect thereof and access thereto.

2. No occupancy or separate operation of part of the Work will be accomplished prior to compliance with the requirements of Paragraph 5.09 with respect to property insurance.

14.06 Final Inspection

A. Upon written notice from CONTRACTOR that the entire Work or an agreed portion thereof is complete, DESIGN PROFESSIONAL will make a final inspection with CITY and CONTRACTOR and will notify CONTRACTOR in writing of all particulars in which this inspection reveals that the Work is incomplete or defective. CONTRACTOR shall immediately take such measures as are necessary to complete such Work or remedy such deficiencies.

14.07 Final Payment

A. Application for Payment

1. After CONTRACTOR has completed all corrections required by Paragraph 14.06 to the satisfaction of DESIGN PROFESSIONAL and CITY's Representative and delivered in accordance with the Contract Documents all maintenance and operating instructions, schedules, guarantees, Bonds, certificates or other evidence of insurance required by Paragraph 5.04, certificates of inspection, marked-up record documents (as provided in Paragraph 6.13) and other documents, CONTRACTOR may make application for final payment following the procedure for progress payments.

2. The final Application for Payment shall be accompanied (except as previously delivered) by:

a. all documentation required by the Contract Documents, including but not limited to the evidence of insurance required by Subparagraph 5.04 B.7; and

b. 01290.14 "Contractor Affidavit for Final Payment" from CONTRACTOR and 01290.15 "Subcontractor Affidavit for Final Payment" from all Subcontractors, regardless of tier.

B. Review of Application and Acceptance

1. If, on the basis of DESIGN PROFESSIONAL's and CITY's Representative's observation of the Work during construction and final inspection, and DESIGN PROFESSIONAL's and CITY's Representative's review of the final Application for Payment and accompanying documentation as required by the Contract Documents, DESIGN PROFESSIONAL and CITY's Representative are satisfied that the Work has been completed and CONTRACTOR's other obligations under the Contract Documents have been fulfilled, DESIGN PROFESSIONAL will, within ten (10) days after receipt of the final Application for Payment, indicate in writing DESIGN PROFESSIONAL's and CITY's Representative's recommendation of payment and present the Application to CITY for payment. At the same time DESIGN PROFESSIONAL will also give written notice to CITY and CONTRACTOR that the Work is acceptable subject to the provisions of Paragraph 14.09.

2. Otherwise, DESIGN PROFESSIONAL will return the Application to CONTRACTOR, indicating in writing the reasons for refusing to recommend final payment, in which case CONTRACTOR shall make the necessary corrections and resubmit the Application to DESIGN PROFESSIONAL. After the presentation to CITY of the Application and accompanying documentation, in appropriate form and substance, including applicable federal and state prevailing wage provisions, and with DESIGN PROFESSIONAL's recommendation and notice of acceptability, the amount recommended by DESIGN PROFESSIONAL will become due and will be paid by CITY to CONTRACTOR in accordance with Laws and Regulations.

14.08 Final Completion Delayed

A. If, through no fault of CONTRACTOR, final completion of the Work is significantly delayed and if DESIGN PROFESSIONAL so recommends and CITY concurs, CITY shall, upon

receipt of CONTRACTOR's final Application for Payment and recommendation of DESIGN PROFESSIONAL, and without terminating the Contract, make payment of the balance due for that portion of the Work fully completed and accepted. If the remaining balance to be held by CITY for Work not fully completed or corrected is less than the retainage stipulated in the Supplementary Conditions, and if Bonds have been furnished as required in Paragraph 5.01, the written consent of the surety to the payment of the balance due for that portion of the Work fully completed and accepted shall be submitted by CONTRACTOR to DESIGN PROFESSIONAL with the Application for Payment. Payment shall be made under the terms and conditions governing final payment, except that it shall not constitute a waiver of Claims.

14.09 Waiver of Claims

A. The making and acceptance of final payment will constitute:

1. a waiver of all claims by CITY against CONTRACTOR, except claims previously made in writing and still unsettled, or claims arising from defective Work appearing after final inspection pursuant to Paragraph 14.06, from failure to comply with the Contract Documents or the terms of any special guarantees specified therein, or from CONTRACTOR's continuing obligations under the Contract Documents; and

2. a waiver of all Claims by CONTRACTOR against CITY other than those previously made in writing pursuant to Paragraphs 16.02 and 16.03 and still unsettled.

14.10 Completion of Work by CITY

A. If CITY must complete the Work, all costs and charges incurred by CITY, together with the cost of completing the Work under the Contract, will be deducted from any monies due or which may become due CONTRACTOR. If such expense exceeds the sum which would have been payable under the Contract, then CONTRACTOR and the surety shall be liable and shall pay to CITY the amount of such excess.

ARTICLE 15 SUSPENSION OF WORK AND TERMINATION

15.01 CITY May Suspend Work

A. Notwithstanding any other provision of this Contract, at any time and without cause, and at its sole and absolute discretion, CITY, may suspend the Work or any portion of the Work by written notice to CONTRACTOR, which will initially fix the date on which Work will be resumed. CONTRACTOR shall resume the Work on the date so fixed in the notice unless the date is changed by a subsequent written notice from CITY. CONTRACTOR may be allowed an adjustment in the Contract Price or an extension of the Contract Times, or both, directly attributable to any suspension if CONTRACTOR makes a Claim therefore in accordance with Article 16.

B. CONTRACTOR will not be allowed an adjustment in the Contract Price or an extension of the Contract Times if CITY suspends the Work because CONTRACTOR's acts or omissions create or cause an emergency that CITY believes affects the safety or protection of persons, the Work, or property at the Site or adjacent thereto. CITY may order CONTRACTOR to stop the Work, or any portion thereof, until the cause for such order has been adequately addressed by CONTRACTOR; however, this right of CITY to stop the Work shall not give rise to any duty on the part of CITY to exercise this right for the benefit of CONTRACTOR, any Subcontractor, Supplier, other individual or entity or any surety or employee or agent of any of them.

15.02 CITY May Terminate for Default

A. CONTRACTOR may be deemed in default and CITY may terminate the services of CONTRACTOR upon the occurrence of any one or more of the following events:

1. CONTRACTOR fails to perform the Work in accordance with the Contract Documents (including, but not limited to, failure to supply sufficient skilled workers or suitable materials or equipment or failure to adhere to the progress schedule established under Paragraph 2.06 and 2.07 as adjusted from time to time pursuant to Paragraphs 6.04, 6.05, 12.02 and 12.03);

2. CONTRACTOR abandons the Work or declares its intention to abandon the Work;
3. CONTRACTOR assigns or attempts to assign its rights or obligations under this Contract or any part thereof to any third party without the prior written consent of CITY;
4. CONTRACTOR fails to make prompt payment duly owing to any subcontractor for Work completed in accordance to the Contract Documents or material supplier for materials delivered for incorporation into the Work within thirty (30) calendar days after payment was due;
5. CONTRACTOR fails to achieve the required dates of substantial and final completion;
6. CONTRACTOR disregards Laws or Regulations of any public body having jurisdiction;
7. CONTRACTOR disregards the authority of DESIGN PROFESSIONAL or OWNER;
or
8. CONTRACTOR otherwise violates in any substantial way any provisions of the Contract Documents.

B. CITY may, after giving CONTRACTOR (and the surety) seven (7) days written notice and to the extent permitted by Laws or Regulations, terminate the services of CONTRACTOR, exclude CONTRACTOR from the Site and take possession of the Work and of all CONTRACTOR's tools, appliances, construction equipment and machinery at the Site and use the same to the full extent they could be used by CONTRACTOR (without liability to CONTRACTOR for trespass or conversion), incorporate into the Work all materials and equipment stored at the Site or for which CITY has paid CONTRACTOR but which are stored elsewhere, and finish the Work as CITY may deem expedient. In such case, CONTRACTOR shall not be entitled to receive any further payment until the Work is finished. If the unpaid balance of the Contract Price exceeds all costs, losses and damages (including but not limited to all fees and charges of engineers, architects, attorneys, and other professionals and all court or arbitration or other dispute resolution costs) sustained by CITY arising out of or resulting from completing the Work, such excess may be paid to CONTRACTOR. If such costs, losses and damages exceed such unpaid balance, CONTRACTOR shall pay the difference to CITY within fourteen (14) calendar days of CITY'S demand for payment. When exercising any rights or remedies under this Paragraph CITY shall not be required to competitively bid this work unless required by law.

C. Where CONTRACTOR's services have been so terminated by CITY, the termination will not affect any rights or remedies of CITY against CONTRACTOR then existing or which may thereafter accrue. Any retention or payment of moneys due CONTRACTOR by CITY will not release CONTRACTOR from liability.

D. If, after a default termination, it is determined that the CONTRACTOR was not in default, the rights and obligations of the parties shall be the same as if the termination had been issued for the convenience of the CITY. The CITY shall then be liable to CONTRACTOR for only those costs enumerated in paragraph 15.03.

15.03 CITY May Terminate for Convenience

A. Notwithstanding any other provision of this Contract, upon seven (7) calendar days written notice to CONTRACTOR, CITY may, at its sole and absolute discretion, without cause and without prejudice to any other right or remedy of CITY, elect to terminate the Contract. In such case, CONTRACTOR shall, with thirty (30) calendar days of receiving notice of termination under this paragraph, submit to CITY its statement of costs and expenses and shall be paid:

1. for completed and acceptable Work executed in accordance with the Contract Documents prior to the effective date of termination, including fair and reasonable sums for overhead and profit on such Work;

2. for expenses sustained prior to the effective date of termination in performing services and furnishing labor, materials or equipment as required by the Contract Documents in connection with uncompleted Work, plus fair and reasonable sums for overhead and profit on such expenses;

3. for all costs, losses and damages incurred in settlement of terminated contracts with Subcontractors, Suppliers and others; and

4. for reasonable expenses directly attributable to termination if approved in advance by CITY.

B. CONTRACTOR shall not be paid on account of loss of anticipated profits or revenue or other economic loss arising out of or resulting from such termination.

C. CONTRACTOR waives any costs not submitted to CITY pursuant to paragraph 15.03.A.

D. CITY shall, within thirty (30) calendar days after receipt of CONTRACTOR's statement, pay CONTRACTOR all amounts it determines are properly determined.

ARTICLE 16 CLAIMS AND DISPUTES

16.01 Definition

A. A Claim is a demand or assertion by the CONTRACTOR seeking, as a matter of right, the adjustment of Contract price and/or times with respect to the terms of the Contract.

16.02 Written Notice and Burden of Proof

A. Claims must be made by written notice pursuant to Paragraph 17.01. The written notice shall clearly indicate that the CONTRACTOR is making a claim. The responsibility to substantiate Claims shall rest with the CONTRACTOR. No Claim may be made under this Contract except as provided in this Article.

B. Certification of Claim: The written notice of Claim shall include the following statement signed by the CONTRACTOR's representative: "The CONTRACTOR certifies that all statements made and the facts set out in this claim are true and correct and that no false records have been submitted in support of this claim." **Strict compliance with this paragraph shall be a condition precedent to the creation, existence or validity of any Claim.**

16.03 Time Limits on Claims

A. The CONTRACTOR must give notice to the CITY within fourteen (14) calendar days after the denial of a request for or failure to reach an agreement on a change in Contract Price and/or change in Contract Time pursuant to Article 11 and Article 12 respectively. After the fourteen (14) day period for making Claims has expired, the Claim shall be considered waived.

B. The CONTRACTOR shall submit the Claim to the CITY's Representative.

16.04 Continuing Contract Performance

A. Pending final resolution of a Claim, unless otherwise agreed in writing, the CONTRACTOR shall proceed diligently with performance of the Work and the CITY shall continue to make payments in accordance with the Contract Documents. The CITY may, but is not obligated to, notify the Surety of the nature and amount of the Claim.

16.05 Injury or Damage to Person or Property

A. If either party to the Contract suffers injury or damage to person or property because of an act or omission of the other party, of any of the other party's employees or agents, or of others for whose acts that party is legally liable, written notice of the injury or damage, whether or not insured, shall be given to the other party within a reasonable time not exceeding thirty (30) days after first observance. The notice shall provide sufficient detail to enable the other party to investigate the matter.

16.06 Initial Resolution of Claims and Disputes

A. After the CONTRACTOR has submitted the Claim to the CITY'S Representative, the CITY'S Representative and CONTRACTOR'S Representative shall conduct a settlement conference within fourteen (14) calendar days from the date of receipt of the Claim. If the Claim is not settled within seven (7) calendar days following the date of the settlement conference, the CITY'S Representative and the CONTRACTOR's Representative shall state, in writing, following the conclusion of the seven (7) calendar day period, their respective position as to the matters in dispute.

B. The CITY'S and CONTRACTOR'S statement of positions shall state all known factual grounds for each party's position. If the dispute remains unresolved at the end of the seven (7) calendar days from submission of the parties' written position statements, the CONTRACTOR shall have the right to proceed with the pursuit of Claims pursuant to paragraph 16.07.

C. If a Claim has been resolved, the OWNER will prepare or obtain appropriate documentation.

16.07 Final Resolution of Claims and Disputes

A. All administrative procedures set forth in this contract must first be exhausted before suit is filed.

B. If the CITY'S Representative and the CONTRACTOR'S Representative are unable to resolve the dispute pursuant to 16.06, the parties must submit their statements of position to the Director, who shall review the Claim and make a decision within fourteen (14) calendar days.

C. Absent fraud, gross mistake or bad faith, the Director's decision shall be final and binding on CITY and CONTRACTOR within fourteen (14) calendar days after issuance. The CONTRACTOR shall give written notice to the CITY stating its intent to submit its Claim to a court of law pursuant to paragraph 17.05.A. within thirty (30) calendar days after notice of Director's decision.

D. The time frames for the Director's decision and for CONTRACTOR'S written notice of intent may be tolled by participation in voluntary mediation. Mediator selection and the procedures to be employed in voluntary mediation shall be mutually acceptable to the parties. Costs of the mediator shall be shared equally among the parties participating in the mediation. In no event shall any time frame be tolled more than 30 days for mediation. However, mediation may be employed at any time at the discretion and mutual agreement of the parties.

E. If the dispute is not resolved during voluntary mediation, The CONTRACTOR agrees that it will file no suit based on facts or evidentiary materials that were not presented for consideration to the CITY during the mediation process or of which the CONTRACTOR had knowledge and failed to present during the administrative procedures.

ARTICLE 17 MISCELLANEOUS

17.01 Giving Notice

A. Whenever any provision of the Contract Documents requires the giving of written notice, it will be given by personal delivery, by registered or certified mail, postage prepaid, to the last business address known to the giver of the notice or by confirmed electronic facsimile transmission. Notice is effective on the date of personal delivery, deposit of registered or certified mail, postage prepaid, or confirmed electronic facsimile transmission.

17.02 Computation of Times

A. When any period of time is referred to in the Contract Documents by days, it will be computed to exclude the first and include the last calendar day of such period. If the last day of such period falls on a Saturday or Sunday or on a day made a legal holiday by the law of the applicable jurisdiction, such day will be omitted from the computation.

17.03 Cumulative Remedies

A. The duties and obligations imposed by these General Conditions and the rights and remedies available hereunder to the parties hereto, and, in particular but without limitation, the

warranties, guarantees and obligations imposed upon CONTRACTOR and all of the rights and remedies available to CITY and DESIGN PROFESSIONAL hereunder are in addition to, and are not to be construed in any way as a limitation of, any rights and remedies available to any or all of them which are otherwise imposed or available by Laws or Regulations, by special warranty or guarantee or by other provisions of the Contract Documents, and the provisions of this Paragraph will be as effective as if repeated specifically in the Contract Documents in connection with each particular duty, obligation, right and remedy to which they apply.

17.04 Survival of Obligations

A. All representations, indemnifications, warranties, and guarantees made in, required by, or given in accordance with the Contract Documents, as well as all continuing obligations indicated in the Contract Documents will survive final payment, completion, and acceptance of the Work or termination or completion of the Contract.

17.05 Controlling Law

A. This Contract shall be construed and governed in accordance with the laws of the State of Missouri without giving effect to Missouri's choice of law provisions. The CITY and CONTRACTOR: (1) shall submit exclusively to the jurisdiction of the state and federal courts located in Jackson County, Missouri and no other; (2) shall waive any and all objections to jurisdiction and venue; and (3) shall not raise forum non conveniens as an objection to the location of any litigation.



SUPPLEMENTARY CONDITIONS

Project/Contract Number: 60800073/9848

Project Title: Emergency Transmission Water Main Repair

These Supplementary Conditions amend or supplement the General Conditions of the Construction Contract and other provisions of the Contract Documents as indicated below. All provisions that are not so amended or supplemented remain in full force and effect.

SC-1.01 Article 1, Paragraph 1.01 Defined Terms, is amended by adding the following new Subparagraph 1.01 A.55.

55. Water Services Department – Water Services Department of Kansas City, Missouri.

SC-2.03 A. Article 2, Paragraph 2.03, Copies of Documents, is amended by deleting Paragraph 2.03 A and replacing it with the following:

A. CITY shall furnish to CONTRACTOR up to one (1) copies of the Specifications, including Addenda.

SC-4.02 Article 4, Paragraph 4.02, Subsurface and Physical Conditions; Subparagraphs A and B are supplemented as follows:

In the preparation of the Contract Documents, no reports of explorations and tests of subsurface conditions at or contiguous to the Site of the Work have been prepared.

In the preparation of the Contract Documents, no drawings of physical conditions in or relating to existing surface or subsurface structures which are at or contiguous to the Site of the Work are available.

SC-4.06 Article 4, Paragraph 4.06, Asbestos, Lead-Based Paint, PCBs, Petroleum Waste or Radioactive Material, Subparagraphs A and B are supplemented as follows:

In the preparation of the Contract Documents, no reports of explorations and tests of any Hazardous Environmental Condition(s) at the Site of the Work have been prepared.

SC- 5.01 A. Article 5, Paragraph 5.01, Performance, Payment and Other Bonds, Subparagraph A, second sentence, is revised as follows:

These Bonds shall remain in effect at least until three (3) years after the date when final payment becomes due, except as provided otherwise by Laws or Regulations or by the Contract Documents.

SC-5.03 A. Article 5, Paragraph 5.03 Certificates of Insurance, Subparagraph A is amended by adding the following Subparagraph 1:

1. CONTRACTOR shall obtain evidence that all Subcontractors have in force the required coverage in the amounts required by these Contract Documents, and evidence that each is current on its unemployment insurance payments before Subcontractors begin Work at the Site. CONTRACTOR shall retain such evidence in its files and make available to CITY within ten (10) days after written request.

SC-5.06 A. Article 5, Paragraph 5.06, Property Insurance, Paragraph A, is amended by adding the following after the first sentence:

Property Insurance will not be required on this contract.

SC-6.06 A.1 Article 6, Paragraph 6.06 Substitutes and "Or-Equal" Items, Paragraph A is amended by adding the following at the end of Paragraph A.1:

Proposed "or-equal" items must be submitted to CITY at least 10 days prior to Bid date at the following address:

Water Services Department
4800 E 63rd Street
Kansas City, Missouri 64130
Attn: Jason Wright, Project Manager

Only Bidders may submit proposed "or-equal" items and such items must require no change in related Work. Acceptance by CITY of any proposed "or-equal" items will be made by Addendum only.

SC-6.06 A.2. Article 6, Paragraph 6.06 Substitutes and "Or-Equal" Items, Paragraph A is amended by adding the following at the end of Paragraph A.2:

Proposed substitute items must be submitted to CITY's Representative not later than 10 days prior to the time the item is to be incorporated into the Work. Only CONTRACTOR may submit proposed substitute items, and such items must be submitted to CITY's Representative on the standard City form 01630 - Substitution Request. Acceptance by CITY of any proposed substitute item will be made by Change Order.

SC-6.10. Article 6, Paragraph 6.10, Compliance with Laws and Regulations, is amended by adding the following new Subparagraphs immediately following Subparagraph 6.10 I 2:

a. CONTRACTOR will be required to comply with wage rates as follows:

County – Cass, Clay, Jackson, Platte

Work Type: State – Heavy

SC-6.10. Article 6, Paragraph 6.10, Compliance with Laws and Regulations, is amended by adding the following new Subparagraph 6.10 S:

1. "Resident Laborers" means laborers who have been residents of the State of Missouri for at least thirty days and who intend to remain Missouri residents, and residents of Nonrestrictive States.

2. "Nonrestrictive States" means states identified by the Missouri Department of Labor and Industrial Relations Division of Labor Standards that have not enacted state laws restricting Missouri laborers from working on public works projects. A list of Nonrestrictive States can be found on the Division web site at <http://www.dolir.mo.gov/ls/index.htm>.

3. A period of Excessive Unemployment is declared when the Missouri Department of Labor and Industrial Relations Division of Labor Standards provides notice of such declaration. When in effect, notice will be provided on the Division web site at <http://www.dolir.mo.gov/ls/index.htm>. It is CONTRACTOR's obligation to determine whether a period of Excessive Unemployment is in effect when this Contract is let.

4. CONTRACTOR agrees to follow the provisions of Section 290.560 - 290.575 RSMo and agrees that if a period of Excessive Unemployment has been declared at any point during the term of this Contract, it will employ and require all Subcontractors of whatever tier to employ only Resident Laborers for the Work to be performed under this CONTRACT. Provided, however, CONTRACTOR may use laborers who are not Resident Laborers when

Resident Laborers are not available or are incapable of performing the particular type of work involved if CONTRACTOR so certifies in writing to CITY and CITY issues a written approval. This provision does not apply to regularly employed nonresident executive, supervisory or technical employees.

SC-6.11. Article 6, Paragraph 6.11, Taxes, is amended by adding the following sentence to Subparagraph 6.11 B:

B. Tax Compliance. The following subparagraphs apply if the Contract is over \$160,000.00.

SC-12.01 Article 12, Paragraph 12.01, Time of the Essence is amended by adding the following new Subparagraphs immediately following Subparagraph 12.01 A:

B. Starting and Completion

1. Times stated in the Contract Documents are of the essence of the Contract. CONTRACTOR will likely have to work outside of normal work hours and in unfavorable weather conditions in order to meet these performance requirements. Once the Work starts, CONTRACTOR shall continuously pursue completion of the Work.
2. The Work under this contract will primarily relate to transmission main priority 3 emergency work and critical valve repairs. It may also include other lower-priority work with priority codes 0, 1, and 2. All work orders must be completed within the following completion times. These completion times shall be calculated as the number of days from the date the work order is assigned to CONTRACTOR to the time it is complete.

Code 3 – 24 hours

Code 2 – 12 calendar days

Code 1 – 21 calendar days

Code 0 – 30 calendar days

Note: Work on Code 3 emergency main breaks can commence prior to the approval of any CITY permits. CONTRACTOR shall be able to provide three complete repair crews at once when needed to respond to multiple simultaneous main breaks.

C. Liquidated Damages

1. If a work order is not completed within the period stated in Paragraph 12.01 A.2, CONTRACTOR shall pay to CITY the amount of **ONE HUNDRED DOLLARS** (\$100) as liquidated damages for each Calendar Day, per work order, that is incomplete. A work order is considered complete for the purpose of meeting these performance requirements when the leak has been repaired per CITY standards, the site has been backfilled and is ready for restoration, and the CONTRACTOR has provided the required information to close the work order in the CITY's work order system. The amount of liquidated damages shall be deducted from any payments due or to become due to the CONTRACTOR.
2. The CITY may suspend accrual of liquidated damages for delays out of the control of CONTRACTOR if CONTRACTOR can demonstrate such delays per section 12 of

Specification 00700, General Conditions. On particularly involved work orders, CONTRACTOR and CITY may negotiate a construction schedule based on the specific work order requirements. Both parties realize that weather conditions may impede the schedule of some construction work. CONTRACTOR shall strive to meet these performance criteria in spite of normal year-round weather conditions. The CITY may suspend accrual of liquidated damages for an extended period of extreme weather. If an extended period of extreme weather is encountered, it shall be the responsibility of CONTRACTOR to demonstrate that additional completion time should be awarded.

Whether or not any liquidated damages are assessed and the amount thereof shall be based on a review of Work Orders and other required documentation. As part of the payment application, the CONTRACTOR shall provide a detailed listing of work orders completed during the month including the work order number, address, cost, date assigned, and date completed in Microsoft Excel format. Work Orders shall be invoiced in the next pay application following their completion. If any given work order is rejected by CITY because it does not meet the requirements of these contract specifications, it will not be considered complete until it has been corrected and accepted by CITY.

SC-13.07 Article 13, Paragraph 13.07, Correction Period, Subparagraph A is amended as follows:

The correction period set forth in Paragraph 13.07 A shall be three (3) years instead of one (1) year, which longer period of time shall also be applicable to the correction period set forth in Paragraph 13.07 C. All other provisions of Paragraph 13.07 remain unchanged except as necessary to accommodate the revised length of the correction period.

SC-14.02 A. Article 14, Paragraph 14.02, Application for Progress Payments, Subparagraph A is amended by deleting Item 3 and adding the following:

3. CITY shall make payments to CONTRACTOR monthly on or about the 15th day of each month. In the event multiple Work Orders have been satisfactorily completed since the previous billing, the individual payments for each Work Order may be combined on one payment application. All Work covered by a payment becomes CITY's property, provided that the Work paid for remains the sole responsibility of CONTRACTOR until all terms and conditions of the Contract have been met.

SC-14.04. Article 14, Paragraph 14.04, Substantial Completion, Subparagraph A is supplemented as follows:

- A. To be considered substantially complete, the following items of the Work must be operational and ready for CITY's continuous use as intended:

All assigned Work Orders completed in accordance with DIV01 - 01000 Project Requirements.

SC-14.05 Article 14, Paragraph 14.05, Partial Utilization is amended by adding the following new Subparagraph A.3. immediately following Subparagraph 14.05 A.2:

1. CITY at any time may make a written request to CONTRACTOR to permit CITY to take over operation of any part of the Work although it is not substantially complete. A copy of the request will be sent to DESIGN PROFESSIONAL, and within a reasonable time thereafter CITY, CONTRACTOR and DESIGN PROFESSIONAL shall make an inspection of that part of the Work to determine its status of

completion and will prepare a list of the items remaining to be completed or corrected thereon before final payment. If CONTRACTOR does not make written objection to CITY and DESIGN PROFESSIONAL that such part of the Work is not ready for separate operation by CITY, DESIGN PROFESSIONAL will finalize the list of items to be completed or corrected and will deliver such lists to CITY and CONTRACTOR. DESIGN PROFESSIONAL will also make a written recommendation as to the division of responsibilities pending final payment between CITY and CONTRACTOR with respect to security, operation, safety, maintenance, utilities, insurance, warranties and guarantees for that part of the Work, which recommendation will become binding upon CITY and CONTRACTOR at the time when CITY takes over such operation (unless they shall have otherwise agreed in writing and so informed DESIGN PROFESSIONAL). During such operation and prior to Substantial Completion of such part of the Work, CITY shall allow CONTRACTOR reasonable access to complete or correct items on said list and to complete other related Work.

SC-17.06 Article 17, Miscellaneous, is amended by adding the following Paragraph(s) immediately following Paragraph 17.05:

17.06 The CONTRACTOR agrees to enter into up to four (4) successive renewal to this Contract if so requested by the CITY. The determination to renew the Contract will be at the sole discretion of the CITY where such renewal would be in the best interest of the CITY. Upon renewal of the contract, an increase in a Unit Price, if any, will be determined solely by the CITY, and if needed, will not exceed the change in the Consumer Price Index for the period since the Contract was signed. The US All City Average Consumer Price Index – All Urban Consumers (CPI-U) (seasonally adjusted, all items, and current base) will be used. The values used to calculate the maximum potential percent increase will be the value from the month the Contract is executed to the most current monthly value available at the time the Contract is renewed. Values will be from the web site for the Bureau of Labor Statistics, Consumer Price Index.

SECTION 00830

PREVAILING WAGE

1. Annual Wage Order No. ____ (add correct AWO # here)
2. **0830.03 Division of Labor Standards Rules & Regulations** are incorporated into and made part of this Contract and are available at <http://s1.sos.mo.gov/cmsimages/adrules/csr/current/8csr/8c30-3.pdf>



ADDENDUM NUMBER _____

Project Number 60800073

Project Title Water Department Emergency Transmission Water Main Repair

[NOTE: Add Month/Date/Year for which this Addendum is officially posted by City. Be certain to remove this note before final document is printed.]

ISSUE DATE: _____

[NOTE: Addenda are used to clarify, revise, add to, or delete information in the original bidding documents or in previous addenda prior to opening of bids. Items should be organized in the same order as the original bidding documents Table of Contents. Cite the specific bidding document and the specific location within it where each change is to be made followed by the detailed change. If entire pages or documents are replaced or added as accompanying attachments, state the title of the document and the specific page number(s) removed and/or added. (e.g., Delete Section 01011 - Summary pages 1-6 and add the attached Section 01011 - Summary pages 1-10.). Be certain to remove this note before final document is printed.]

[NOTE: Add Month/Date/Year. Be certain to remove this note before final document is printed.]

Bidders are hereby notified that the Bidding and Contract Documents for the above project, for which Bids are to be received on _____, are amended as follows:

[NOTE: If the bid date is being changed add Month/Day/Year; if not, delete this sentence. Be certain to remove this note before final document is printed.]

The Bid date for this Project stated in Document 00130 - Invitation to Bid shall be changed to: 2:00 PM, on _____.

Information to Bidders The following is provided to Bidders for information only:

[NOTE: Include items under this heading such as Pre-bid meeting attendance list, soils report, etc.; items that should not be contractual, but are useful information to Bidders. Delete this heading and introduction if not applicable for this Addendum. Be certain to remove this note before final document is printed.]

- 1.
- 2.

[NOTE: Include Bidder/Proposer questions and answers to those questions. If questions are resolved by a contractual change, reference the contract section and make the appropriate change in one of the sections below. Delete this heading and table if not applicable for this Addendum. Be certain to remove this note before final document is printed.]

Q1.	
A1.	
Q2.	
A2.	

Q3.	
A3.	

[NOTE: Under the following sections, include changes to those documents under the heading with this same title found in Document 00010 - Table of Contents, (including changes to previous addenda). Format for revisions provided below. Delete sections if not applicable to this addendum. Be certain to remove this note before final document is printed.]

Bidding Requirements

1. Add the following section(s):
 - a. Document, Sec. __, Subparagraph __, Page ____
 - b. Document, Sec. __, Subparagraph __, Page ____

[OR]

2. Delete the following section(s):
 - a. Document, Sec. __, Subparagraph __, Page ____
 - b. Document, Sec. __, Subparagraph __, Page ____

[OR]

3. Delete and replace the following section(s):
 - a. Delete Document, Sec. __, Subparagraph __, Page ____ and replace with the following Document, Sec. __, Subparagraph __, Page ____:
 - b. Delete Document, Sec. __, Subparagraph __, Page ____ and replace with the following Document, Sec. __, Subparagraph __, Page ____:

Contracting Requirements

- 1.
- 2.

Specifications

- 1.
- 2.

Drawings:

- 1.
- 2.

NOTE: Bidders must acknowledge receipt of this Addendum by listing the number and date, where provided, on the Bid Form - Document 00410.



REQUEST FOR INTERPRETATION

Project Number 60800073

Project Title Water Department Emergency Transmission Water Main Repair

Contractor _____

RFI Number _____ Date _____

From: _____

To: _____

Re: _____

Spec. Sec. Ref:	Paragraph:	Drawing Ref:	Detail:
-----------------	------------	--------------	---------

Signed: _____

Response: _____

Attachments

Response From: _____ To: _____ Date Transmitted: _____ Date Rec'd: _____

Signed: _____
Design Professional

Signed: _____
Owner's Representative

- Distribution:
- Owner
 - Contractor
 - Construction Manager
 - Design Professional
 - Consultant _____
 - Other _____



SUPPLEMENTAL DESIGN INSTRUCTION

Project Number 60800073 _____

Project Title Water Department Emergency Transmission Water Main Repair

To Contractor _____

From: _____ SDI No _____ Issue Date: _____

The Work shall be carried out in accordance with the following supplemental instructions issued in accordance with the Contract Documents without change in Contract Price or Contract Times. Proceeding with the Work in accordance with these instructions indicates your acknowledgement that there will be no change in the Contract Price or Contract Times.

Description:

Attachments (*List*)

(Signature) Design Professional

Date

- Distribution:
- Owner
 - Contractor
 - Construction Manager
 - Design Professional
 - Consultant _____
 - Other _____



REQUEST FOR PROPOSAL

Project Number 60800073

Project Title Water Department Emergency Transmission Water Main Repair

To Contractor _____

From: _____ RFP No _____ Issue Date: _____

Please submit an itemized proposal for changes in the Contract Price and Contract Times for proposed modifications to the Contract Documents described herein. Submit proposal within _____ days, or notify the Owner in writing of the date on which you anticipate submitting your proposal.

This is NOT a Change Order, a Work Change Directive or a direction to proceed with the work described in the proposed modifications.

Description:

Attachments

Prepared by Design Professional

Prepared by Construction Manager

REQUESTED by OWNER'S Representative

- Distribution: Owner
 Contractor
 Construction Manager
 Design Professional
 Consultant _____
 Other _____



CHANGE ORDER

Project Number _____

Project Title _____

Change Order No: _____ Date of Issuance: _____

Ordinance No: _____ Ordinance Effective Date: _____

Contract Notice To Proceed Date: _____

To CONTRACTOR:

The Contract is changed as follows: _____

This Change Order constitutes compensation in full on behalf of the Contractor and its subcontractors and suppliers for all costs, including impact costs and extended general conditions, and markups directly and indirectly attributable to the Work changes ordered herein, for all delays related thereto and for performance of the changes within the time stated. Contractor hereby releases all claims for delay, interruption, extended general conditions, impact and cumulative impact claims for this Work.

[Note: Identify the specific attachments; example:"Attachment A, Additional Scope of Services." Delete **all** notes before printing final]

See Attached Document(s).

[Note: If the CO does not change the Contract Price, use "Director" instead of "Director of Finance"]

Not valid until signed by the Director of Finance.

The original Contract Price was	\$0.00
Net change by previously authorized Change Orders	\$0.00
The Contract Price prior to this Change Order was	\$0.00
The Contract Price will be (<input type="checkbox"/> increased by) (<input type="checkbox"/> decreased by) (<input type="checkbox"/> unchanged)	\$0.00
The new Contract Price including this Change Order will be	\$0.00

[Note: If revised, establish and enter new dates. If unchanged, enter current contract dates.

If you are only changing the Final Completion date, add the following reference:

"The Contract Time for Final Completion will be . . ."]

The Contract Time will be (<input type="checkbox"/> increased by) (<input type="checkbox"/> decreased by) (<input type="checkbox"/> unchanged)	() calendar days
The date of Substantial Completion as of the date of this Change Order therefore is	Enter Date
The date of Final Completion as of the date of this Change Order therefore is	Enter Date

Project No. & Title
 Change Order No.

[Note: Include any required additional signatures.]

DESIGN PROFESSIONAL:	By:	Date:
	Title:	
CONTRACTOR:	By:	Date:
	Title:	
CITY:	By:	Date:
	Title:	

Approved as to form: _____
 Assistant City Attorney

[Note: If this CO does not change the Contract Price, delete the cert. of funds by Finance Director but send signed copy to Finance.]

I certify there is a balance otherwise unencumbered to the credit of the appropriation to which the above amount is chargeable, and a cash balance otherwise unencumbered in the treasury to the credit of the fund from which payment is to be made, each sufficient to meet the above obligation.

By: _____
 Director of Finance Date

- Distribution:
- CITY
 - CONTRACTOR
 - DESIGN PROFESSIONAL

REMINDER: CONTRACTOR is responsible for considering the effect this Change Order may have on its ability to meet or exceed the D/M/WBE participation amounts in its Contractor Utilization Plan (CUP) as amended by any previously approved Request for Modification/Substitution. If CONTRACTOR will not be able to achieve the approved participation amounts in performing the work included within this Change Order, or if CONTRACTOR needs to retain the services of additional D/M/WBEs not previously listed in its CUP, CONTRACTOR is advised to submit a Request for Modification/Substitution.



WORK CHANGE DIRECTIVE

Project Number 60800073

Project Title Water Department Emergency Transmission Water Main Repair

No.: _____ Date of Issuance: _____

TO:
(CONTRACTOR)

You are directed to proceed promptly with the following work:

Description:

Purpose of Work Change Directive:

Attachments: *(List documents supporting change)*

If the above work results on a change in the Contract Price or Contract Times, any request for a Change Order based thereon will involve one or more of the following methods of determining the effect of the change(s).

Method of determining change in
Contract Price:

Method of determining change in
Contract Times:

- Unit Prices
- Lump Sum
- As Stipulated in General Conditions
- Other _____

- CONTRACTOR's Records
- DESIGN PROFESSIONAL's Records
- City's Records
- Other _____

Estimated increase (decrease) in Contract Price:
\$ _____

Estimated increase (decrease) in Contract Times:
Substantial Completion: _____ days;

If the change involves an increase, the estimated Amount is not to be exceeded without further authorization.

Final Completion: _____ days.
If the change involves an increase, the estimated times are not to be exceeded without further authorization.

Recommended:

Recommended:

Recommended:

DESIGN PROFESSIONAL

Construction Manager

City

By (Authorized Signature)

By (Authorized Signature)

By (Authorized Signature)

Distribution:

- City
- Contractor
- Construction Manager

- Design Professional
- Consultant
- Other

WORK CHANGE DIRECTIVE (“WCD”) INSTRUCTIONS

[Note: Do not attach these instructions to the WCD Form]

A. GENERAL INFORMATION

This document was developed for use in situations involving changes in the Work which, if not processed expeditiously, might delay the Project. These changes are often initiated in the field and may affect the Contract Price or the Contract Times. This is not a Change Order, but only a directive to proceed with Work that may be included in a subsequent Change Order. If the WCD may result in an increase in the Contract Price, a contract impact cost analysis must be performed prior to issuing the WCD. Availability of funds and authorization to expend funds must be part of the analysis.

For supplemental instructions and minor changes not involving a possible change in the Contract Price or the Contract Times a Supplemental Design Instruction may be used.

B. COMPLETING THE WORK CHANGE DIRECTIVE FORM

Based on conversations between Design Professional, City’s Representative and CONTRACTOR, Design Professional must complete the following:

DESCRIPTION: shall include a summary of the Work included in the WCD. Additional information may be attached to the WCD to further define the scope.

PURPOSE OF WORK CHANGE DIRECTIVE: will identify clearly if the Work included in the WCD is an addition, deletion, revision, or some combination.

ATTACHMENTS: shall identify all attachments included in and made a part of the WCD. Be certain that attachments are clearly labeled.

METHOD OF DETERMINING CHANGE, IF ANY, IN CONTRACT PRICE: Mark the method to be used in determining the final cost of Work involved and the estimated net effect on the Contract Price. If the change involves an increase in the Contract Price and the estimated amount is approached before the additional or changed Work is completed, another WCD must be issued to change the estimated price. Do not leave blank spaces or write “To be determined” (or “TBD”). An estimated dollar figure must be assigned to the Work. If the WCD is not likely to change the Contract Price, the space for estimated increase (decrease) should be marked “No Change in Price”.

METHOD OF DETERMINING CHANGE, IF ANY, IN CONTRACT TIMES: Mark the method to be used in determining the change in Contract Times and the estimated increase or decrease in Contract Times. If the change involves an increase in the Contract Times and the estimated times are approached before the additional or changed Work is completed, another WCD must be issued to change the times or CONTRACTOR may stop the changed Work when the estimated times are reached. Do not leave blank spaces or write “To be determined” (or “TBD”). If the WCD is not likely to change the Contract Times, the space for estimated increase (decrease) should be marked “No Change in Times”.

Once Design Professional has completed and signed the form, all copies should be sent to CITY for authorization because Design Professional does not have authority to authorize changes in Price or Times. Once authorized by CITY, a copy must be sent by Design Professional to CONTRACTOR. Price and Times may only be changed by Change Order signed by CITY, Design Professional, and CONTRACTOR. If the value of the work included in the WCD exceeds the contingency or budget available for the contract, staff must obtain written approval from the Director or his or her designee before the WCD is issued. A Director or his or her designee may not approve a WCD that will exceed City Council authorization. If the work included in the WCD is needed as a result of an emergency, staff may proceed with the issuance of the WCD without

prior written approval even if the value of the work added is expected to exceed the contract contingency balance.

Once the Work covered by this directive is completed or final cost and times are determined. CONTRACTOR must submit proper documentation for inclusion in a Change Order.

IF THIS IS A DIRECTIVE TO PROCEED WITH A CHANGE THAT MAY AFFECT THE CONTRACT PRICE OR THE CONTRACT TIMES A CHANGE ORDER, IF ANY, MUST BE PROCESSED PROMPTLY.

Affiant's signature

Subscribed and sworn to before me this _____ day of _____, 20____.

Notary Public

My Commission expires:

Civil Rights and Equal Opportunity Department Civil Rights and Wage Assurances

Non-discrimination in Employment. Contractor shall not discriminate against any employee or candidate for employment on the basis of an individual's race, hair texture or hair style associated with an individual's race, color, sex, religion, national origin, or ancestry, disability, sexual orientation, gender identity, age, or in any other manner prohibited by Chapter 38 of the City Code. Contractor shall not engage in any discrimination as prohibited by Chapter 3 of the City Code.

Ban the Box in Hiring and Promotion.

(a) Pursuant to Section 38-104, City Code Ordinances, Contractor shall not base a hiring or promotional decision on an applicant's criminal history or sentence related thereto, unless the employer can demonstrate that the employment-related decision was based on all information available including consideration of the frequency, recentness and severity of a criminal record and that the record was reasonably related to the duties and responsibilities of the position.

(b) Notwithstanding subsection (a), Contractor may inquire about an applicant's criminal history after it has been determined that the individual is otherwise qualified for the position, and only after the applicant has been interviewed for the position. Any such inquiry may be made of all applicants who are within the final selection pool of candidates from which a job will be filled.

(c) This provision shall not apply to positions where employers are required to exclude applicants with certain criminal convictions from employment due to local, state or federal law or regulation.

Title VI of the Civil Rights Act of 1964. Title VI of the Civil Rights Act of 1964 requires that no person in the United States shall, on the grounds of race, color, or national or origin (including limited English proficient individuals), be excluded from participation in, be denied the benefits of, or be subjected to discrimination under any program or activity receiving federal financial assistance. The City of Kansas City, Missouri requires compliance with the requirements of Title VI in all of its programs and activities regardless of the funding source.

Contractor shall not discriminate on the grounds of race, color, or national or origin (including limited English proficient individuals).

Quality Services Assurance Act. If this Contract exceeds \$160,000.00, Contractor certifies Contractor will pay all employees who will work on this Contract in the city limits of Kansas City, Missouri at least \$15.00 per hour in compliance with the City's Quality Services Assurance Act,

Civil Rights and Equal Opportunity Department Civil Rights and Wage Assurances

Section 3-66, Code of Ordinances or City has granted Contractor an exemption pursuant to the Quality Services Assurance Act.

Anti-Discrimination Against Israel. If this Contract exceeds \$100,000.00 and Contractor employs at least ten employees, pursuant to Section 34.600, RSMo., by executing this Contract, Contractor certifies it is not currently engaged in and shall not, for the duration of this contract, engage in a boycott of goods or services from the State of Israel; companies doing business in or with Israel or authorized by, licensed by, or organized under the laws of the State of Israel; or persons or entities doing business in the State of Israel.

Affirmative Action. If this Contract exceeds \$300,000.00 and Contractor employs fifty (50) or more people, Contractor shall comply with City's Affirmative Action requirements in accordance with the provisions of Chapter 3 of City's Code, the rules and regulations relating to those sections, and any additions or amendments thereto; in executing any Contract subject to said provisions, Contractor warrants that it has an affirmative action program in place and will maintain the affirmative action program in place for the duration of the Contract. Contractor shall not discriminate against any employee or applicant for employment because of race, color, sex, religion, national origin or ancestry, disability, sexual orientation, gender identity or age in a manner prohibited by Chapter 3 of City's Code. Contractor shall:

- (a) Execute and submit the City of Kansas City, Missouri CREO Affirmative Action Program Affidavit warranting that the Contractor has an affirmative action program in place and will maintain the affirmative action program in place for the duration of the Contract.
- (b) Submit, in print or electronic format, a copy of Contractor's current certificate of compliance to the City's Civil Rights and Equal Opportunity Department (CREO) prior to receiving the first payment under the Contract, unless a copy has already been submitted to CREO at any point within the previous two (2) calendar years. If, and only if, Contractor does not possess a current certification of compliance, Contractor shall submit, in print or electronic format, a copy of its affirmative action program to CREO prior to receiving the first payment under the Contract, unless a copy has already been submitted to CREO at any point within the previous two (2) calendar years.
- (c) Require any Subcontractor awarded a subcontract exceeding \$300,000.00 to affirm that Subcontractor has an affirmative action program in place and will maintain the affirmative action program in place for the duration of the subcontract.
- (d) Obtain from any Subcontractor awarded a subcontract exceeding \$300,000.00 a copy of the Subcontractor's current certificate of compliance and tender a copy of the same, in print or

Civil Rights and Equal Opportunity Department Civil Rights and Wage Assurances

electronic format, to CREO within thirty (30) days from the date the subcontract is executed. If, and only if, Subcontractor does not possess a current certificate of compliance, Contractor shall obtain a copy of the Subcontractor's affirmative action program and tender a copy of the same, in print or electronic format, to CREO within thirty (30) days from the date the subcontract is executed.

City has the right to take action as directed by City's Civil Rights and Equal Opportunity Department to enforce this provision. If Contractor fails, refuses or neglects to comply with the provisions of Chapter 3 of City's Code, then such failure shall be deemed a total breach of this Contract and this Contract may be terminated, cancelled or suspended, in whole or in part, and Contractor may be declared ineligible for any further contracts funded by City for a period of one (1) year. This is a material term of this Contract.

Compliance with Laws. Contractor shall comply with all federal, state and local laws, ordinances and regulations applicable to the work and this Agreement. Contractor shall maintain in effect all the licenses, permissions, authorizations, consents and permits that it needs to carry out its obligations under this Agreement.

Prevailing Wage. If the Agreement exceeds \$75,000.00 and any of the Services performed by Contractor includes construction, reconstruction, improvement, enlargement, alteration, painting and decorating, or major repair, that is subject to the Missouri Prevailing Wage Law (Section 290.210, RSMo – 290.340, RSMo), Contractor shall immediately notify the City prior to performing Services so the parties can execute an agreement that incorporates, the appropriate Wage Order. Contractor shall comply with all requirements of Section 290.210, RSMo – 290.340, RSMo even if Contractor fails to notify the City.



KCMO PRELIMINARY VENDOR SECURITY QUESTIONNAIRE

FORM 2- CONFIDENTIAL and PROPRIETARY

This vendor or 3rd party-vendor cybersecurity questionnaire is required to be completed by all potential vendors proposing or already doing business with the City of Kansas City, Missouri (KCMO) or with any KCMO affiliated agency or department.

Additional information may be requested depending on the answers or lack of answers that are provided. (Please attach all related information and documentation including contact information).

This information has been deemed non-discoverable under the MO Sunshine Law. The City will not be releasing this form under the MO Sunshine Law.

Vendor Questions: (Please provide requested details under each question or append to the end of this document with reference to the specific question being answered)

Yes No - As a supplier to the City of KCMO, does your company have a written controls plan that contains the administrative, technical, and physical safeguards you use to collect, process, protect, store, transmit, dispose, or otherwise handle KCMO data (e.g., Information Security Plan)? Please provide.

Yes No - As a supplier to the City of KCMO, does your system or application which will be storing our company data provide access control mechanisms (e.g., unique user IDs, passwords standards, role-based access)? Please explain.

Yes No - As a supplier to the City of KCMO, does the system or application provide multi-tenant controls for separation of users and data within the service? If yes, please provide policy/procedures.

Yes No - As a supplier to the City of KCMO, does your company utilize encryption methods for data in transit and data at rest where technically possible and legally permissible? Please explain i.e. use of data serialization for privacy.

Yes No - As a supplier to the City of KCMO, does your company have a written business continuity/disaster recovery plan, which is tested on a periodic basis? Please elaborate and provide a copy your plan(s)



Yes No - As a supplier to the City of KCMO, does your company ensure adequate steps are taken to guard against unauthorized access to KCMO data (e.g., firewall)? Please list the technology and processes that are in place.

Yes No - As a supplier to the City of KCMO, does your company maintain up-to-date versions of anti-virus software, anti-malware, antispyware, and operating systems security patches? Please elaborate.

Yes No - As a supplier to the City of KCMO, will your company actively monitor and manage your IT security environment to prevent security incidents or breaches? Please elaborate.

Yes No - As a supplier to the City of KCMO, does your company perform application security testing? Please describe and provide samples along with methodology.

Yes No - As a supplier to the City of KCMO, does your company have a written plan to promptly identify, report, and respond to breaches of security related to KCMO data (e.g., incident response plan)?

Yes No - As a supplier to the City of KCMO, will third party vendors (e.g., subcontractor, managed shared hosting) be used by your company and be restricted from having access to the system or application data of KCMO?

Yes No - As a supplier to the City of KCMO, does your company provide assurance (in the form of a written report) for you and your third-party vendor's security and controls while KCMO data is being collected, processed, and retained? If yes, please provide your most current report

Please provide the results of your last security audit you have for your company and any relevant third-party service provider your company contracts.

What specific services are included in KCMO monthly service fee? What services will be an additional fee?

What is or will be the length of this contract? What is or will be the Service Level Agreement (SLA) with KCMO and how often is KCMO able to change or modify this SLA?

ADDITIONAL INFORMATION

1. KCMO reserves the right to perform an audit at any time during the term of any agreement between KCMO and a vendor to verify their compliance with the



answers provided.

2. KCMO may require additional information based the answers or lack of answered provided.
3. Vendors should provide copies of requested documentation including any certifications, prior assessments, or test results.



SECTION 01000
PROJECT REQUIREMENTS

1. GENERAL DESCRIPTION OF WORK:

A. Purpose of the Contract

1. The Contractor will provide two to three crews a week to supplement KC Water repair efforts. It is anticipated that 3 to 5 work orders per week will be given to the Contractor. Work will primarily relate to repair or replacement of water transmission assets, including large valves. On occasion, work may also include repairs to distribution system assets.

2. The KC Water will provide the work assignments to the Contractor. Job assignments will be made in the form of a Hansen Work Order (WO) using a Hansen WO number. Contractor shall complete work orders within the time frames stated in section 00800 – Supplementary General Conditions. Once a work order is started, Contractor shall pursue the WO until it is completed. Overtime or carrying the job over to the next day will be permitted only if specific approval is requested and given. WOs will frequently be given for work on nights/weekends for emergency (Code 3) repairs which generally require a 1 to 2 hour response.

B. Contractor's responsibility

4. The Contractor shall:

- i. Identify and provide email addresses and mobile phone numbers for the Contractor's Corporate person in-charge, project manager, superintendent, and crew chief(s). All of these people will have mobile devices capable of sending and receiving emails.
- ii. Provide field crews with notebook computers or tablets of sufficient capacity to run the City's GIS mapping software and to record daily work activities and work items electronically.
- iii. Contacting Missouri One Call.
- iv. Obtain permits not obtained by KC Water
- v. Advise affected consumers that they will be out of water for the time estimated to complete the repair.
- vi. Coordinate, as appropriate, with the KC Water repair inspector, Meter Field Services Division, Pipeline Division, KC Water Engineering, Water Dispatch, and other appropriate parties regarding details and schedule of the repair.
- vii. Provide traffic control and other safety devices
- viii. Perform test shuts. Valves larger than 12" shall be operated by a KC Water repair inspector.
- ix. Notify KC Water Dispatch when starting or Completing a work order or valve shut.
- x. Complete the work in accordance with City and KC Water standards.
- xi. Take pre, during, and post-construction photos of each work site and uploading these photos to the WO associated with the work site.

- xii. Provide daily E-Mail updates of status of assigned work orders.
- xiii. Complete other Contractor's responsibilities described elsewhere in the Contract documents.

C. Work Order Process

1. KC Water will provide the work assignments .
2. WOs may be given for emergency (Code 3) repairs which generally require a 1 to 2 hour response. Code 3 repairs include large leaks with damage to property or other facilities, puts consumers out of water, or otherwise creates a hazard to public safety.
3. The WO will be given to the Contractor via email although the information may be initially conveyed verbally. The WO details will include the WO number, location (generally a street address), asset size and type, and description of the problem with priority code.
4. Contractor's personnel shall locate and operate valves required for valve repairs or replacements in accordance with KC Water procedures, including but not limited to, scheduling of test shuts and main shuts with KC Water and providing proper notification to customers impacted by the shuts.
5. Contractor shall schedule shuts and repairs in coordination with KC Water repair inspector so as to minimize water disruptions to KC Water customers.
6. Once the work is begun, the Contractor will continue working on the job in an expeditious manner until it is completed.
7. The Contractor is responsible for protecting from damage any other utilities, services, lines, pipes, and other surface or subsurface features that are near the repair site. If such items are damaged by the Contractor, the Contractor shall be responsible for having such items repaired or replaced.
8. The Contractor shall minimize the damage to the street, curb, driveways, sidewalks, grassed areas, and surfaces during his repairs.
9. The Contractor shall make the repairs in accordance with City and KC Water standards and at the direction of KC Water personnel. Contractor shall comply with KC Water standard operating procedures for preventing contamination of water mains, disinfection, flushing, de-chlorination, and putting mains back into service.
10. The Contractor shall backfill the excavation as required by KC Water specifications and in accordance with the current Kansas City SR-1 specification for street patches. Contractor shall pour the concrete trench cap to surface level when working in asphalted areas. Concrete surface shall be smooth and level with the surrounding pavement with a medium broom finish. Contractor shall cause a restoration work order to be linked to the repair work order in CITY's Hansen work order system at the time when the repair work order is closed.
11. KC Water will obtain the Excavation and Pavement Degradation permits from the Public Works Department's permit desk. Unless otherwise directed by KC Water, the Contractor will be responsible for restoring the repair sites in accordance with current KCMO Public Works Standards and KC Water Standards and

Specifications for Water Main Extensions and Relocations, except asphalt will e completed by others.

12. The Contractor shall utilize Dispatch and the Contractor Webapp to upload the following when completing a WO, and submit to KC Water:

Hansen Number: Dispatch

Address: Dispatch

Type of Work: Dispatch

Reason for Work: Dispatch

Summary of Work Performed: Dispatch

Type of Break and Type of Pipe: Dispatch

Date & Time on Site: Dispatch

Date & Time off Site: Dispatch

Restoration Needed: Dispatch

Street Plate: Dispatch

Job Site Forman Name: Dispatch

Dispatcher Name and Time Called: Dispatch

Valve Shut #: Dispatch

Construction Photos; Pre, During and Post (Attach to Hansen WO):Webapp

2. CONTRACT SPECIFICATIONS:

A. The work shall conform to these Project Specifications, contained within the Project Manual, and to the latest revision of the KC Water Standards and Specifications for Water Main Extensions and Relocations and the Rules and Regulations for Water Service Lines, which are made a part hereof by reference. These Standards and Specifications in pdf format are available for viewing and printing from the City website at <http://www.kcmo.org>.

B. The term “Engineer” as used in the aforesaid Standards and Specifications shall mean the Engineering Services Division of the Water Services Department of the City, or any engineer or agent designated by the Director in responsible charge of the work.

C. In cases where the WSD Standards and Specifications for Water Main Extensions and Relocations and Rules and Regulations for Water Service Lines, as referenced, conflict with these Project Specifications or the Project Drawings, the Project Specifications or the Project Drawings shall govern.

3. MATERIALS FURNISHED BY THE OWNER: The Owner will furnish the Contractor and without charge to the Contractor, the materials listed below. If the Owners stores are out-of-stock of materials requested by the Contractor, those materials shall be obtained by the Contractor. Reimbursement for these materials shall be made in accordance with Article 11 of the General Conditions of this document. All other materials required to complete the work in accordance with the Contract Documents shall be furnished and

installed by and at the expense of the Contractor.

<u>Item</u>	<u>Quantity</u>
Ductile Iron Pipe	as needed
All hydrant overhaul parts	as needed
KCMO spec fire hydrant	as needed
Resilient wedge MJ gate valves	as needed
Butterfly valves	as needed
Valve bases, covers, boxes, risers, op nuts	as needed
Miscellaneous pipe & fittings	as needed

All material furnished by the Owner which is damaged, lost or stolen after its acceptance by the Contractor shall be replaced at the expense of the Contractor with like material purchased from the Owner.

The Contractor, or his authorized representative, shall sign a bill of receipt for all materials withdrawn from the Water Services Department Stores. The Contractor will be responsible for pickup of materials at the Water Services Department Stores and for delivery to the work site.

All materials withdrawn from the Water Services Department Stores that are not incorporated in the work shall be returned to the Water Services Department Stores. All such material not returned shall be charged to the Contractor and deduction therefore shall be made from the final payment estimate.

All salvaged hydrants and hydrant parts shall be returned to the Owner at Water Services Department Stores unless otherwise directed for disposal.

4. BACKFILL: All backfill shall be thoroughly compacted in strict conformance with section 02200, Earthwork of the Contract Specifications, KC Water Standards and Specifications for Water Main Extensions and Relocations, and the Public Works Department Pavement Restoration Standards SR-1.

5. FACILITIES:

A. The Owner will furnish without charge all necessary water for filling, flushing, and testing the completed line.. Use of City's water facilities shall be at the direction of the Water Services Department so that water service to customers served by the facilities is not impaired. Under any conditions, water shall not be wasted. Any water furnished by the Owner must be obtained from the Owner's existing main. All material and service needed to obtain water for construction purposes shall be provided by the Contractor at his sole cost and expense.

B. All power for lighting, operation of the Contractor's plant or equipment, or for any other use which may be required for proper completion of the work to be performed shall be provided by the Contractor at his sole cost and expense.

6. RIGHTS-OF-WAY: The Owner will provide right-of-way necessary for construction of the water main where it is in public thoroughfares, city streets, Park Board property, county roads, state highways, or where it crosses private property. The Contractor shall confine his construction operations to the immediate vicinity of the repair location, and shall use due care in placing construction tools, equipment, excavated materials, and pipeline materials and supplies so as to cause the least possible damage to property and interference with public traffic.

Should it become necessary that the Contractor use or occupy the land outside the Owner's right-of-way, the Contractor shall obtain written consent from or execute a written agreement with the owner and tenant of such permitting such operation. The Contractor shall neither enter for pipe delivery nor occupy for any other purpose with men, tools, equipment, construction materials, or excavated materials any private property outside the right-of-way boundaries without such written permission from the owner and tenant of the entered or occupied property. Each owner and tenant of land or other property so occupied shall be notified by the Contractor not less than five (5) days prior to such occupation.

7. POSITION, LINE OR GRADE:

The Contractor shall furnish all labor and materials necessary in laying out the work. The Contractor shall be responsible for setting any offset stakes he may require or required by the Engineer. Contractor to locate right-of-ways as required to lay out work.

8. DISINFECTION:

All disinfection work shall be in strict conformance with Section 02675 – Water Main Testing, Disinfection, and Dechlorination of KC Water Standards and Specifications for Water Main Extensions and Relocations.

9. SETTING FIRE HYDRANTS: When installing hydrants, reaction backing shall be placed between the back of the elbow and the end of the trench as shown on the Standard Construction Details. The bottom of the hydrant shall be placed on a flat stone slab approximately two (2) feet square. Before backfilling the trench, one (1) cubic yard of coarse stone approximately six (6) inches in size shall be placed around the hydrant in conformance with the details shown on the Drawings. The weep holes of the hydrant shall stand plumb with the center of the steamer nozzle maintained at least eighteen (18) inches to twenty (20) inches above the existing ground grade at each hydrant location unless otherwise specified; and when placed behind curbs, the centerline of the hydrant shall be at least thirty-six (36) inches from the back of the curb. Hydrants shall be rotated so as to have the steamer nozzle facing the street or, rotated to face any direction as required by the WSD.

All new hydrant settings shall be as shown on the detail drawings and shall include all necessary excavation and backfill to make the installation complete. The area around each hydrant and hydrant valve cover shall be thoroughly compacted to prevent settlement of these areas.

The Contractor will locate the installation point of each hydrant as shown on the Plans. The

Contractor shall furnish all labor and material necessary in laying out the work. The Contractor shall be responsible for setting any offset stakes he may require. The Engineer shall approve the staked location of each hydrant before its installation.

10. SANITARY PROVISIONS: The Contractor shall provide sanitary conveniences for use of all persons employed on the work. All sanitary conveniences shall conform to the regulations of the Health Department of the City, County, and State. At the completion of the work, all signs and traces of such sanitary provisions shall be removed.

11. CLEAN-UP:

All excavated material in excess of that necessary to fill the trench shall be removed and disposed of by the Contractor.

Surplus pipeline materials, tools, and temporary structures shall be removed by the Contractor; all rubbish shall be hauled away by the Contractor and the construction site shall be left clean.

12. PROJECT MEETINGS:

Preconstruction Conference: At a mutually agreeable time prior to starting work, a conference will be held to review schedules, submittal procedures, payment procedures, and to establish a working understanding between the parties. Attending shall be the Owner or his representative, the Contractor and his Superintendent, and representatives of his Subcontractors, if any.

Progress Meetings: Contractor's Superintendent shall attend monthly progress meetings at a facility determined by Owner. At each meeting, the progress of the work shall be reviewed and any required adjustments shall be made in the construction schedule to insure completion in accordance with the contract documents.

13. EROSION AND SEDIMENT CONTROL: All work shall conform to the latest revision of the Kansas City, Missouri Erosion and Sediment Control Specifications which is made a part hereof by reference.

14. GUIDELINES FOR OPEN EXCAVATIONS: Required excavations shall be restored to the level of the adjacent surfaces as soon as practicable. Unsupervised open excavations on public properties are discouraged at all times. Every person who for any purpose makes or causes to be made any excavation in, upon, under, through or adjoining any street, sidewalk, alley, park, boulevard, parkway or any other public properties, and shall leave any part or portion thereof open shall provide effective protection to the public.

All excavations in roadways shall be protected and secured in compliance with existing federal, state and local codes and standards, including, but not limited to the most current editions of the Manual of Uniform Traffic Control Devices.

All unsupervised excavations not within roadways shall be protected and secured. A protective cover over an excavation shall be installed so that it can sustain the weight of any persons and/or objects placed upon it. The cover shall be fixed to the ground so it cannot be moved. Protective covers shall have no opening(s) or protuberance(s) of sufficient size to cause a fall and/or injury. Advance warning devices shall be installed as necessary.

Any excavation that is not covered, shall be fenced in such a way that it surrounds the entire area under excavation so as to prevent entry by any persons. The fencing shall be a minimum of 42" in height. The fence shall be constructed in such a manner that it is adequately secured and will remain upright at all times under normal site conditions.

All protective coverings and/or fences on excavations shall be inspected by Contractor at least daily to assure integrity. Protective coverings and/or fences in heavily trafficked areas shall be inspected more often as necessary.

END OF SECTION 01000

SECTION 01016

WATER MAINS NEAR SEWERS

PART 1 GENERAL

1.1 Section Description

- A. This section provides for the required procedures where water main construction work is in close proximity to existing sewers.

1.2 Section Includes

- A. Horizontal Separation
- B. Vertical Separation

1.3 Related Sections

- A. Section 02200 - Excavation and Trenching

1.4 Horizontal Separation

- A. Water mains shall be laid at least 10 feet, horizontally, from any sewer. When local conditions prevent a horizontal separation of 10 feet, a water main may be laid closer than 10 feet to a sewer, provided that the water main is laid in a separate trench, or on an undisturbed earth shelf located on one side of the sewer, at such an elevation that the bottom of the water main is at least 18 inches above the top of the sewer. Water mains shall be laid such that there is a minimum of 18" clearance between the pipe wall and the exterior of any manhole and/or inlet on the sewer line. When it is impossible to obtain proper horizontal separation as stipulated above, the sewer must be reconstructed of ductile iron pipe meeting the requirements of Section 02618, prestressed concrete cylinder pipe meeting the requirements of Section 02619, or PVC pressure pipe and shall be pressure-tested to assure water-tightness before backfilling. PVC pipe will conform to AWWA C-900 or C-905.
- B. The required length of sewer to be replaced or constructed of pressure pipe will be the length necessary to achieve 10 feet horizontal separation.

1.5 Vertical Separation:

- A. Whenever water mains must cross above sewers, the water main shall be laid at such an elevation that the bottom of the water main is at least 18" above the top of the sewer. A full length of pipe shall be centered over the sewer to be crossed so that the joints will be equally distant from the sewer and as far away as possible. This vertical separation shall be maintained for that portion of the water main located within 10 feet, horizontally, of any sewer it crosses.

When it is impossible to obtain minimum vertical separation set forth above the sewer must be reconstructed of ductile iron, prestressed concrete cylinder, or PVC pipe, and shall be pressure tested to assure water tightness, before backfilling. PVC pipe will conform to AWWA C-900 or C-905.

- B. Whenever a water main must cross under a sewer, a vertical separation of 18 inches between the bottom of the sewer and the top of the water main shall be achieved. A full length of pipe shall be centered under the sewer to be crossed so that the joints will be equally distant from the sewer and as far away as possible. This vertical separation shall be maintained for that portion of the water main located within 10 feet, horizontally, of any sewer it crosses. The sewer shall be reconstructed of ductile iron pipe, prestressed concrete cylinder pipe, or PVC pressure pipe for a distance of 10 feet on either side of the crossing, and shall be pressure tested to assure water tightness before backfilling. PVC pipe will conform to AWWA C-900 or C-905. Where these conditions cannot be met, the CITY shall be consulted as to the precautions to be taken for protection of the public water supply.

- C. When PVC pipe is used for sewer reconstruction, the following guide shall apply:

<u>Depth of cover over sewer</u>	<u>Use</u>
Up to 22'	SDR-26
22' up to 30'	SDR-21

PART 2 PRODUCTS

- A. Not Used

PART 3 EXECUTION

- A. Reconstruction of sewer lines included in this Work shall be done in accordance with Construction Detail Drawing No. 01016-1.

END OF SECTION

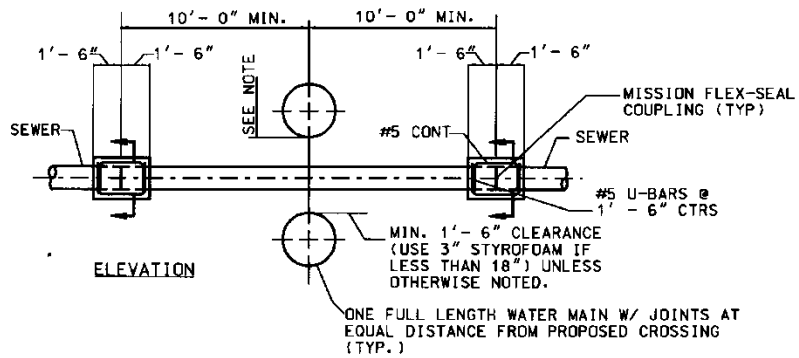

NOTE:
 IF WATER MAIN CROSSES BELOW SEWER,
 OR IF WATER MAIN CROSSES LESS THAN 18" ABOVE SEWER,
 SEWER IS TO BE REPLACED W/ CL 52 DIP
 OR PCCP OR PVC, AND JOINTS ENCASED AS
 DETAILED ABOVE.
 PVC PIPE SHALL CONFORM TO AWWA C-900 OR C-905

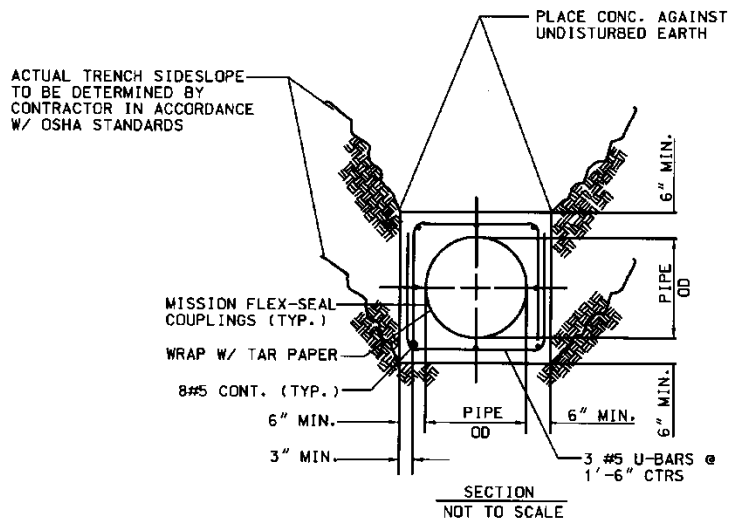

SEWER CROSSING DETAIL

WATER SERVICES DEPARTMENT CITY OF KANSAS CITY, MISSOURI

REVISED: JULY, 2006 CONSTRUCTION DETAIL DRAWING NO. 01016-1



ALLOWANCE AUTHORIZATION

Project Number 60800073

Project Title Water Department Emergency Transmission Water Main Repair

To: _____

Authorization Number: _____

Re: _____

From: _____

Date: _____

Contract For: _____

You are authorized to perform the following item(s) of work and to adjust the Allowance Sum accordingly:

This is NOT a CHANGE ORDER and does NOT INCREASE OR DECREASE the CONTRACT AMOUNT.

Original Allowance \$ _____

Allowance Expenditures prior to this Authorization \$ _____

Allowance Balance prior to this Authorization \$ _____

Allowance will be [increased] [decreased] by this Authorization \$ _____

New Allowance Balance \$ _____

APPROVAL RECOMMENDED

CITY APPROVAL

Design Professional Date

City's Representative Date

CONTRACTOR ACCEPTANCE

Construction Manager Date

Contractor Date

Attachments:

- Distribution:
- City
 - Contractor
 - Construction Manager
 - Design Professional
 - Consultant
 - Other

**SECTION 01270
MEASUREMENT AND PAYMENT**

PART 1 – GENERAL

1.1 GENERAL

- A. Payment for Work performed by the Contractor under these Contract Documents will be made in accordance with the General Conditions at the approved Contract Unit Price unless otherwise stated in the Contract Documents. Such payment shall compensate the Contractor for all labor, including wages, fringe benefits, employee taxes, employee liability and worker compensation insurance, vehicles, equipment, tools, overhead and profit, bonding, insurance, and risk necessary to complete the work orders.
- B. Work required to complete assigned work orders, but which has no corresponding unit or lump sum price, shall be a subsidiary item unless otherwise stated in the Contract Documents. Contractor's cost to complete subsidiary items shall be included in the Unit Prices in the Bid Form.
- C. Along with each Application for Payment, Contractor shall include documentation of the quantities included in the pay application. As part of this documentation, Contractor shall complete a Daily Crew Record for each crew for each assigned work order including Hanson Work Order No., work description, labor, hours, materials, specialized or unique labor, equipment or services used in the repair and other information as directed by Owner. Adequate written documentation must be provided with each Application for Payment to verify the quantities under Items 13 to 20, 22, and all costs incurred under the GC Article 11 Items 24-27.
- D. All charges for crew hours must be fully documented in the hourly wages to workers that are reported in Contractor's Daily Labor Force Reports. Costs for management, supervision, superintendence, and administration shall be included in Item 23 – Monthly Project Superintendence.

PART 2 – DESCRIPTION OF UNIT PRICES

2.1 TWO-PERSON CREWS WITH ALL EQUIPMENT FOR RELATED WORK W/O EXCAVATION (Items 1 -3):

- A. These unit prices include mobilization/demobilization, labor, vehicles, equipment and tools necessary to complete the assigned work orders as described below. Overtime crew rates will be applied when all members of the crew are entitled to receive regular or double overtime pay.

- B. Contractor shall access the City's water GIS database and print system maps of areas required for water main shuts to repair water assets. Field crews shall be equipped with notebook computers of sufficient capacity to run the City's GIS software. Examples of field repairs without excavation include minor repairs to the valve which do not require excavation such as replacing cover and lid, pouring concrete collar, uncovering valve lid and bringing cover and lid to grade with risers, exercising valves with valve keys, and replacing operating nuts using specialized op nut replacement equipment provided by Owner.
- C. Contractor shall locate valves in the field required for main shuts and determine if they are operable. Valves may need to be uncovered, brought to grade, and exercised to ensure operability. One or more backshuts may be necessary behind inoperable valves. Contractor shall schedule the test shut, notify consumers, and conduct the main shuts in accordance with the Owner's Standard Operating Instructions Repairing Water Mains for a Scheduled Shut & Repair and as directed by the Owner.

2.2 TWO-PERSON, THREE-PERSON, OR FOUR-PERSON CREWS WITH ALL EQUIPMENT FOR WATER ASSET REPAIR/REPLACEMENTS (Items 4 – 12):

- A. These unit prices include mobilization/demobilization, utility locates, labor, vehicles and all equipment and tools necessary to complete the assigned work orders as described below including but not limited to excavators, pickup trucks, pavement and pipe saws, hydraulic hammer, loaders, pumps, generators, air compressors and hammers, and small tools. Cost of pickup of materials from the Owner's stores and transport to the site shall be included in this unit price. Overtime crew rates will be applied when all members of the crew are entitled to receive regular or double overtime pay.
- B. Each repair/replacement of water assets shall be made in accordance with Section 02641 of the Standards and Specifications for Water Extensions and Relocations and the Owner's Standard Operating Instructions Repairing Water Mains by removing the leaking valve or pipe section to facilitate the installation of the pre-chlorinated new valve or ductile-iron pipe, spacer, long style solid sleeve(s), and restraining glands as necessary. Ductile iron water pipe is assumed to have an average depth of cover of 5 feet. Installed pipe, valves, fittings, and other appurtenances shall be entirely polywrapped. Job excavated materials may be used for backfill in parkway (grassy) areas when material is suitable for such (i.e. not saturated). Job excavated materials not suitable for use as backfill or surplus job excavated materials shall be removed from the jobsite. Pavement areas shall be backfilled and a concrete pavement base constructed according to the Public Works SR-1 standard for pavement restoration.

The cost of labor and equipment for placing and compacting the pipe embedment and backfill material shall be paid using the appropriate unit price for the crew and equipment. The cost of labor and equipment for preparing, placing, protecting and curing flowable fill and concrete at the work site shall be paid using the appropriate unit price for the crew and equipment. The material costs for pipe embedment, granular backfill, flowable fill, and concrete are included in other Unit Prices. The installation of an asphalt pavement patch and grade and seed in parkways are included in other Unit Prices.

- C. Contractor shall secure each excavation and clean up the site before leaving the jobsite.
- D. All Work Orders shall be completed and signed-off by the Pipeline Area Superintendent or his designee prior to submitting for payment.

2.3 GRANULAR EMBEDMENT (Item 13): The quantity of granular embedment needed for proper pipe bedding to complete each Work Order shall be identified per ton used. Granular embedment shall be clean crushed rock with not less than 95% passing a ½” screen and not more than 5% passing a #4 screen. Payment will be made at the approved contract unit price for granular embedment on the basis of actual quantity of embedment delivered and placed. The cost of labor and equipment for placing and compacting the material as pipe embedment at the work site shall be paid using the appropriate unit price for the crew and equipment.

2.4 UNTREATED AGGREGATE BACKFILL (Item 14): The quantity of untreated aggregate backfill needed for proper compaction to complete each Work Order shall be identified per ton used. Untreated aggregate backfill shall meet the material specification for untreated compacted aggregate in Section 2202 of the Standard Specifications and Design Criteria of the APWA as adopted by KCMO or otherwise approved by City. Payment for untreated aggregate backfill shall be made at the approved contract unit price for untreated aggregate backfill per ton delivered and placed. The cost of labor and equipment for placing and compacting the material at the work site shall be paid using the appropriate unit price for the crew and equipment.

2.5 WASTE MATERIAL, DISPOSAL (Items 15 & 16): Contractor shall be responsible for the removal of all waste materials generated during the completion of the Work Order. Job excavated materials not suitable for use as backfill or surplus job excavated soils, pavement materials removed for the repair or replacement, debris, abandoned pipe and valve materials not directed by Owner for salvage, etc. shall be removed from the jobsite and properly disposed of. Payment will be made per hour the hauling equipment is utilized for the workorder. The unit price shall include all equipment, labor, and disposal fees and any other costs to remove the material from the site and proper disposal.

- 2.6 CONCRETE (Item 17):** The quantity of concrete necessary to complete assigned Work Orders in accordance with all aspects of Contract specifications for pavement restoration (MCIB Mix WA738-3/4-4) and the construction of thrust blocks behind fittings (MCIB Mix WA530-1-4) shall be identified per cubic yard used. Payment for concrete shall be made at the approved contract unit price for concrete per cubic yard delivered and placed. The cost of labor and equipment for preparing, placing, protecting and curing the material at the work site shall be paid using the appropriate unit price for the crew and equipment.
- 2.7 DIGGABLE FLOWABLE FILL (Item 18):** The quantity of diggable flowable fill necessary to complete assigned Work Orders in accordance with all aspects of Contract specifications shall be identified per cubic yard used. Diggable flowable fill (Controlled Low Strength Material) shall meet APWA Section 2602.2 of the Standard Specifications and Design Criteria of the APWA as adopted by KCMO with maximum and minimum compressive strengths of 150 psi and 75 psi, respectively. Payment for diggable flowable fill shall be made at the approved contract unit price for fill per cubic yard delivered and placed. The cost of labor and equipment for preparing and placing the material at the work site shall be paid using the appropriate unit price for the crew and equipment.
- 2.8 On-Call Per Crew (Items 19 & 20):**
- A. **Item 19 Weekday On-Call Per Crew (24 Hour Period):** Payment for weekday emergency on-call will be for each 24 hour period each standby crew(s) is on-call during a weekday Monday 7am through Friday 7am. One to two crews may be needed due to workload. KC Water will notify the Contractor of on-call requirements at least 24 hours in advance.
- B. **Item 20 Weekend/Holiday On-Call Per Crew (24 Hour Period):** Payment for weekend/ holiday emergency on-call will be for each 24 hour period each standby crew(s) is on-call during weekends Friday 7am through Monday 7am or Federal holiday. One to two crews may be needed due to workload. KC Water will notify the Contractor of on-call requirements at least 24 hours in advance.
- 2.9 TWO PERSON CREW WITH ALL EQUIPMENT AND MATERIALS FOR GRADE AND SEED (Item 21):** Such payment and price shall constitute full compensation for all mobilization/demobilization, labor, vehicles, equipment, and materials necessary for placement and spreading of top soil, grading, fertilizing, tilling, seeding, covering and firming, mulching, providing appropriate safety signage and traffic control, and cleanup. This item does not include costs for topsoil in quantities ½ cubic yard or greater per site.
- 2.10 TOPSOIL (Item 22):** Payment for topsoil in quantities of ½ cubic yard or greater per site shall be made at the approved Contract Unit Price for Top Soil per cubic

yard delivered and placed on the site. The cost of labor and equipment for placing, spreading, and firming the material at the work site shall be paid using the unit price for a two person crew for grade and seed.

PART 3 – REIMBURSEMENT OF COSTS FOR SPECIALIZED ITEMS, EQUIPMENT, OR MATERIALS

- 3.1 MONTHLY PROJECT SUPERINTENDENCE (Item 23):** Payment for monthly project superintendence will be a lump sum monthly charge to account for overall project field superintendence, not included in other unit price items.
- 3.2 SPECIALIZED TRAFFIC CONTROL (Item 24):** Payment for specialized traffic control for an assigned Work Order will be made in accordance with Article 11 of the General Conditions of the Contract, including preparation of the traffic control plan, permit fees, and the provision and maintenance of appropriate traffic control devices for the work. Minor traffic control such as placement of traffic cones or barricades at or around the work site or equipment shall be considered subsidiary to the other unit prices.
- 3.2 STREET PLATES (Item 25):** Payment for the provision of street plate(s) over a pavement cut as directed by the Owner for an assigned Work Order will be made in accordance with Article 11 of the General Conditions of the Contract, including the permit fee, street plate rental with delivery and pickup.
- 3.3 MATERIALS NOT AVAILABLE FROM OWNER’S STORES (Item 26):** If materials (pipe, fittings, valves, and appurtenances listed in Section 01000, Paragraph 3 to be furnished by Owner) required for an assigned work order are not available through the Owner’s Stores, upon approval by Owner those materials shall be obtained by the Contractor and delivered to the work site. Reimbursement for these materials shall be made in accordance with Article 11 of the General Conditions of the Contract.
- 3.4 OTHER SPECIALIZED SERVICES (Item 27):** Payment for other specialized and unique services required for assigned work orders and pre-approved, in writing, by the Owner such as welding, close circuit TV of pipelines, shoring, and the cost of labor and equipment for installation/replacement of a valve with size 16-inches in diameter or greater, will be made in accordance with Article 11 of the General Conditions of the Contract.

END OF SECTION



APPLICATION FOR PAYMENT

Project Number

60800073

Project Title

WD Emergency Transmission WMR

Final Payment⁵

CONTRACTOR _____

Address _____

Application Number²: _____

Date: _____

Ordinance/Resolution Number: _____

Effective: _____

PO Number _____

Vendor Number _____

Application for Work Accomplished from _____

to _____

Original Contract Price	[1]		\$	-
Net by Change Orders through _____		[2]	\$	-
Current Contract Price (1+2)		[3]	\$	-
Completed Work	[4]	\$	-	
Disputed Amounts ³	[-]	[4a]	\$	-
Stored Material ⁴	[5]	\$	-	
Disputed Amounts ³	[-]	[5a]	\$	-
Total Completed and Stored to Date (4+5)		[6]	\$	-
Previous Payments	[7]	\$	-	
Previous Retainage	[8]	\$	-	
Total Previous Applications (7+8)		[9]	\$	-
Amount This Application (6-9)		[10]	\$	-
Less Retainage This Application (5%)		[-] [11]	\$	-
Release of Retainage		[12]	\$	-
Total Due This Application (10-11+12)		[13]	\$	-
Liquidated Damages				
Completion of Work	[14]	\$	-	[-] \$ -
Prevailing Wage ⁷	[15]	\$	-	[-] \$ -
MBE/WBE Program ⁷	[16]	\$	-	[-] \$ -
Workforce Program ⁷	[17]	\$	-	[-] \$ -
Total Amount Due Contractor (13 - 14 through 17)		[18]	\$	-

Accompanying Documentation: ^{1, 2, 3, 4, 5, & 6} and any other information as necessary.

NOTE: Initial all figures on this Application and on the Schedule of Values that are changed to correct errors or conform to the amount recommended. Attach explanation of changes that have been made.

CONTRACTOR's Certification:

The undersigned CONTRACTOR certifies that (a) all previous progress payments received from OWNER on account of Work done under this Contract have been applied on account to discharge CONTRACTOR's legitimate obligations incurred in connection with Work covered by all prior Applications for Payment; (b) at time of payment, title of all Work, materials and equipment incorporated into said Work or otherwise listed in or covered by this Application for Payment will pass to OWNER free and clear of all Liens, security interests and encumbrances (except such as are covered by a Bond acceptable to OWNER indemnifying OWNER against any such Lien, security interest or encumbrance); and (c) all Work covered by this Application for Payment is in accordance with the Contract Documents and not defective; and (d) all manufactured goods or commodities used or supplied for this Project are in compliance with Kansas City's Buy America ordinance.

By _____
 Contractor Authorized Representative (Print) Signature

Date _____

State of _____)
 County of _____)SS

Subscribed and Sworn to before me this _____ day of _____.

My commission expires:

Notary Public: _____

DESIGN PROFESSIONAL's Recommendation of Payment:

In accordance with the Contract Documents, based on on-Site observations and the data comprising this application, the DESIGN PROFESSIONAL recommends to the OWNER that to the best of the DESIGN PROFESSIONAL's knowledge, information and belief the Work has progressed as indicated, the quality of the Work is in accordance with the Contract Documents, and the CONTRACTOR is entitled to payment of the Amount above listed in this application.

Name of firm (Print) DESIGN PROFESSIONAL (Print) (Signature)

Date: _____

Construction/Program Manager's Recommendation of Payment: (if applicable)

In accordance with the Contract Documents, based on on-Site observations and the data comprising this application, the Construction/Program Manager recommends to the OWNER that to the best of the Construction/Program Manager's knowledge, information and belief the Work has progressed as indicated, the quality of the Work is in accordance with the Contract Documents, and the CONTRACTOR is entitled to payment of the Amount above listed in this application.

Construction/Program Manager firm (Print) Authorized Representative (Print) (Signature)

Date: _____

City's Representative's Agreement with Recommendation of Payment

City's Representative(print) (Signature) (Date)

City's Approval

The amount previously recommended is approved for payment.

Director or Designee (Print) (Signature) (Date)

¹See General Conditions Article 14.02 A and B

²Proof of tax compliance if 1st payment and if Contract amount exceeds \$150,000.00

³Schedule of Values--Denote any amounts currently disputed in this application. Attach additional dispute documentation if required.

⁴If requesting payment for stored materials, see General Conditions Article 14.02 A.1

⁵If final payment, current proof of tax compliance if Contract is longer than 1 year and amount exceeds \$150,000.00.

⁶ Per General Conditions Sec. 14.02 attach a copy of the most recent 00485.01 M/WBE Monthly Utilization Report, 00485.02 Project Workforce Monthly Report and 00485.03 Company-Wide Workforce Monthly Report CONTRACTOR has submitted to the City's Human Relations Department

⁷Applicable only if final payment

REMINDER: CONTRACTOR is responsible for meeting or exceeding the the D/M/WBE participation amounts in its Contractor Utilization Plan (CUP) as amended by any previously approved Request for Modification/Substitution. Any Change Orders or amendments modifying the amount CONTRACTOR is to be compensated will have correspondingly impacted the amount of compensation due D/M/WBEs for purposes of meeting or exceeding the Bidder/Proposer participation. CONTRACTOR is again reminded to consider the effect of any Change Order or amendment, and to submit a Request for Modification/Substitution if appropriate.

Distribution: Owner Project Manager
 Contractor Design Professional
 Construction Manager _____



SUBCONTRACTORS AND MAJOR MATERIAL SUPPLIERS LIST

Project Number 60800073 Project Title Water Department Emergency Transmission Water Main Repair

From Contractor _____ To _____ Date _____

Spec. No.	Section Title	4	Firm, Address (Check box if Supplier)	Phone, FAX and e-mail	Contact

Attachments:

Signed by: _____ Date _____

Distribution: Owner Contractor Construction Manager Design Professional Consultant Other



CERTIFICATE OF ACHIEVEMENT OF FULL OPERATION

Project/Contract Number 60800073/9848 _____

Project Title Water Department Emergency Transmission Water Main Repair

CONTRACT FOR: _____

CONTRACTOR: _____

DATE OF ISSUANCE: _____

PROJECT OR DESIGNATED PORTION SHALL INCLUDE:

The Work performed under this Smart Sewer Program Contract has been reviewed and found, to the Design Professional's, Project Manager's, and Construction Manager's best knowledge, information, and belief, to have achieved a state of full operation. Achievement of full operation is the state where completion of construction and installation of equipment or infrastructure such that the equipment or infrastructure has been placed into full operation and is expected to both function and perform as designed. The date of Achievement of full operation of this Project is hereby established as _____. This is also the date the work can be utilized for the purposes for which it is intended and is ready for the City's continuous use. The correction period required by the Contract Documents shall commence on this date, except as stated below.

A list of items to be completed or corrected before final payment is attached hereto. The failure to include any items on such list does not alter the responsibility of the Contractor to complete all Work in accordance with the Contract Documents.

CONTRACTOR BY DATE

DESIGN PROFESSIONAL BY DATE

The Contractor will complete or correct the Work on the list of items attached hereto within _____ days from the above date of Achievement of Full Operation.

SMART SEWER PROJECT MANAGER BY DATE

SMART SEWER CONSTRUCTION MANAGER BY DATE

SMART SEWER DIVISION HEAD BY DATE

SMART SEWER OFFICER BY DATE

- Distribution:
- Smart Sewer Officer
 - Smart Sewer Division Head
 - Contractor
 - Construction Manager
 - Design Professional
 - Consultant _____
 - Other _____



CERTIFICATE OF SUBSTANTIAL COMPLETION

Project Number 60800073

Project Title Water Department Emergency Transmission Water Main Repair

CONTRACT FOR: _____

CONTRACTOR: _____

DATE OF ISSUANCE: _____

PROJECT OR DESIGNATED PORTION SHALL INCLUDE:

The Work performed under this Contract has been reviewed and found, to the Design Professional's and/or Construction Manager's best knowledge, information and belief, to be substantially complete. Substantial Completion is the state in the progress of the Work when the Work or designated portion thereof is sufficiently complete in accordance with the Contract Documents so the Owner can occupy or utilize the Work for its intended use. The date of Substantial Completion of Project or portion thereof designated above is hereby established as _____ which is also the date of commencement of applicable warranties required by the Contract Documents, except as stated below:

A list of items to be completed or corrected is attached hereto. The failure to include any items on such list does not alter the responsibility of the Contractor to complete all Work in accordance with the Contract Documents.

CONSTRUCTION MANAGER BY _____ DATE _____

DESIGN PROFESSIONAL BY _____ DATE _____

The Contractor will complete or correct the Work on the list of items attached hereto within _____ days from the above date of Substantial Completion.

CONSTRUCTION MANAGER BY _____ DATE _____

DESIGN PROFESSIONAL BY _____ DATE _____

The Owner accepts the Work or designated portion thereof as substantially complete and will assume full possession thereof at _____ (time) on _____ (date).

OWNER'S REPRESENTATIVE BY _____ DATE _____

Distribution: Owner
 Contractor
 Construction Manager
 Design Professional
 Consultant
 Other _____



PUNCH LIST

Project Number 60800073

Project Title Water Department Emergency Transmission Water Main Repair

CONTRACTOR _____

From _____ Site Visit Date _____

The following items require the attention of the CONTRACTOR for completion or correction. This list may not be all-inclusive, and the failure to include any items on this list does not alter the responsibility of the CONTRACTOR to complete all Work in accordance with the Contract Documents.

Item No.	Location (Area)	Description	Correction/ Completion Date	Verification Check
----------	-----------------	-------------	-----------------------------	--------------------

Attachments

Signed by: _____ Date: _____
DESIGN PROFESSIONAL (Firm/In House)

- Distribution:
- OWNER
 - CONTRACTOR
 - DESIGN PROFESSIONAL
 - Consultant _____
 - Other _____



CONTRACTOR AFFIDAVIT FOR FINAL PAYMENT

Project Number _____

Project Title _____

STATE OF _____)
)SS
COUNTY OF _____)

The Undersigned, _____ of lawful
(Name)

age, being first duly sworn, states under oath as follows:

1. I am the _____ of _____ who is the general
(Title) (CONTRACTOR)
CONTRACTOR for the CITY on Project No. _____ and Project Title _____.

2. All payrolls, material bills, use of equipment and other indebtedness connected with the Work for this Project have been paid and all Claims of whatever nature have been satisfied, as required by the Contract.

3 (✓) ___ Prevailing wage does not apply; or

(✓) ___ All provisions and requirements set forth in Chapter 290, Section 290.210 through and including 290.340, Missouri Revised Statutes, pertaining to the payment of wages to workmen employed on public works projects have been fully satisfied and there has been no exception to the full and complete compliance with these provisions and requirements and the Annual Wage Order contained in the Contract in carrying out the Contract and Work. CONTRACTOR has fully complied with the requirements of the prevailing wage law as required in the Contract and has attached affidavits from all Subcontractors on this Project, regardless of tier, affirming compliance with the prevailing wage law as stipulated in the Contract.

4. I hereby certify that (a) at project completion and pursuant to contractor's final request for payment, contractor achieved (____%) Minority Business Enterprise (MBE) participation and (____%) Women Business Enterprise (WBE) participation on this contract, and (b) listed herein are the names of all certified M/WBE subcontractors, regardless of tier, with whom I, or my subcontractors contracted.

1. Name of MBE/WBE Firm _____
Address _____

Telephone Number (_____) _____
IRS Number _____
Area/Scope*of Work _____
Subcontract Final Amount _____

2. Name of MBE/WBE Firm _____
Address _____

Telephone Number (_____) _____
IRS Number _____
Area/Scope*of Work _____
Subcontract Final Amount _____

List additional subcontractors, if any, on a similar form and attach to the bid.

Supplier** Final Amount: _____

*Reference to specification sections or bid item number.

- (✓) ___ Met or exceeded the Contract utilization goals; or
- (✓) ___ Failed to meet the Contract utilization goals (attach waiver, substitution or modification); or
- (✓) ___ No goals applied to this Project.

5. CONTRACTOR certifies that each Subcontractor has received full payment for its respective work in connection with the Contract.

6. If applicable, I hereby certify that (1) at project completion and pursuant to contractor's final request for payment, contractor achieved, company-wide, at least ten percent (10%) minority workforce participation and two percent (2%) women workforce participation and (2) a true and accurate copy of my final project workforce monthly report is attached. **NOTE: This paragraph is only applicable if you completed a construction contract that was estimated by the City, prior to solicitation, as requiring more than 800 construction labor hours and costing in excess of \$300,000.00. If applicable you MUST attach copies of your final monthly workforce reports.**

7. This affidavit is made in behalf of the CONTRACTOR for the purpose of securing from Kansas City, Missouri, the certification of completion of the Project and receiving payment therefore.

8. If the Contract amount exceeded \$150,000, CONTRACTOR has submitted proof of compliance with the City tax ordinances administered by the City's Commissioner of Revenue and has on file proof of tax compliance from all Subcontractors. If the Contract term exceeded one (1) year, CONTRACTOR has provided proof of compliance with the City tax ordinances administered by the City's Commissioner of Revenue prior to receiving final payment and has on file proof of tax compliance from all Subcontractors prior to the Subcontractor receiving final payment from CONTRACTOR.

CONTRACTOR _____

By _____
(Authorized Signature)

Title _____

On this _____ day of _____, _____, before me appeared _____, to me personally known to be the _____ of the _____,

and who executed the foregoing instrument and acknowledged that (s)he executed the same on behalf of _____ as its free act and deed.

IN WITNESS WHEREOF, I have hereunto set my hand and affixed my official seal on the day and year first above written.

My commission expires:

Notary Public



SUBCONTRACTOR AFFIDAVIT FOR FINAL PAYMENT

Project Number _____

Project Title _____

STATE OF MISSOURI)

) ss:

COUNTY OF _____)

After being duly sworn the person whose name and signature appears below hereby states under penalty of perjury that:

1. I am the duly authorized officer of the business indicated below (hereinafter Subcontractor) and I make this affidavit on behalf of Subcontractor in accordance with the requirements set forth in Section 290.290, RSMo. Subcontractor has completed all of the Work required under the terms and conditions of a subcontract as follows:

Subcontract with: _____, Contractor

Work Performed: _____

Total Dollar Amount of Subcontract and all Change Orders: \$ _____

City Certified MBE WBE DBE NA
List certifications:

2. Subcontractor fully complied with the provisions and requirements of the Missouri Prevailing Wage Law set forth in Sections 290.210, RSMo through 290.340, RSMo.

Business Entity Type:

- Missouri Corporation
- Foreign Corporation
- Fictitious Name Corporation
- Sole Proprietor
- Limited Liability Company
- Partnership
- Joint Venture
- Other (Specify)

Subcontractor's Legal Name and Address

 Phone No. _____
 Fax: _____
 E:mail: _____
 Federal ID No. _____

I hereby certify that I have the authority to execute this affidavit on behalf of Subcontractor.

By: _____
 (Signature)

 (Title)

 (Print Name)

 (Date)

NOTARY

Subscribed and sworn to before me this ____ day of _____, 20____.

My Commission Expires: _____ By _____

Print Name

Title

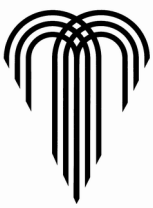

SUBCONTRACTOR AFFIDAVIT FOR FINAL PAYMENT

Project Number 60800073

Project Title Water Department Emergency Transmission Water Main Repair

STATE OF MISSOURI)

) ss:

COUNTY OF _____)

After being duly sworn the person whose name and signature appears below hereby states under penalty of perjury that:

1. I am the duly authorized officer of the business indicated below (hereinafter Subcontractor) and I make this affidavit on behalf of Subcontractor in accordance with the requirements set forth in Section 290.290, RSMo. Subcontractor has completed all of the Work required under the terms and conditions of a subcontract as follows:

Subcontract with: _____, Contractor

Work Performed: _____

Total Dollar Amount of Subcontract and all Change Orders: \$ _____

City Certified MBE WBE DBE NA

List certifications: _____

2. Subcontractor fully complied with the provisions and requirements of the Missouri Prevailing Wage Law set forth in Sections 290.210, RSMo through 290.340, RSMo.

Business Entity Type:

- Missouri Corporation
- Foreign Corporation
- Fictitious Name Corporation
- Sole Proprietor
- Limited Liability Company
- Partnership
- Joint Venture
- Other (Specify)

Subcontractor's Legal Name and Address

 Phone No. _____
 Fax: _____
 E:mail: _____
 Federal ID No. _____

I hereby certify that I have the authority to execute this affidavit on behalf of Subcontractor.

By: _____
(Signature)

(Print Name)

(Title)

(Date)

NOTARY

Subscribed and sworn to before me this _____ day of _____, 20_____.

My Commission Expires: _____ By _____

Print Name

Title



DAILY FIELD OBSERVATION REPORT

Project Number 60800073

Project Title Water Department Emergency Transmission Water Main Repair

Contractor _____

Report Number _____ Date _____ Time _____

Weather

- Clear
- Overcast
- Rain
- Snow
- Foggy
- Cold

- Warm
- Hot
- Temperature Range _____

Site Conditions

- Clear
- Muddy
- Dusty
- _____

Day

- Monday
- Tuesday
- Wednesday
- Thursday
- Friday
- _____

Persons Contacted: _____

Work Observed: _____

Items Discussed: _____

Materials Delivered: _____

Requested Revisions or Interpretations: _____

Nonconforming Work Reported This Date To Contractor: _____

Remarks: _____

Attachments

Signed by: _____

Date: _____

- Distribution:
- Owner
 - Contractor
 - Construction Manager
 - Design Professional
 - Consultant _____
 - Other _____

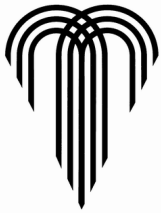

PERIODIC FIELD OBSERVATION REPORT

Project Number 60800073

Project Title Water Department Emergency Transmission Water Main Repair

Contractor _____

Report Number _____ Date _____ Time _____

Weather

- Clear Snow
 Overcast Foggy
 Rain Cold

Site Conditions

- Warm Clear Dusty
 Hot Muddy _____
 Temperature Range _____

Day

- Monday Thursday
 Tuesday Friday
 Wednesday _____

Persons Contacted:

Work Observed:

Items Discussed:

Remarks:

Attachments

Signed by:

Date:

- Distribution: Owner
 Contractor
 Construction Manager
 Design Professional
 Consultant _____
 Other _____



WEEKLY REPORT OF WORKING DAYS

Project Number 60800073

Project Title Water Department Emergency Transmission Water Main Repair

Contractor _____

Report Number _____ Week Ending: _____

DATE:	WORKING DAY	REMARKS		
TOTAL THIS WEEK	PREVIOUSLY	TOTAL TO DATE	WORKING DAYS IN CONTRACT	REMAINING OR OVERTIME

Signed by OWNER'S REPRESENTATIVE _____ Date: _____

Signed by CONTRACTOR _____ Date: _____

Distribution: OWNER CONTRACTOR Construction Manager Design Professional Consultant Other



TRANSMITTAL LETTER

Project Number 60800073

Project Title Water Department Emergency Transmission Water Main Repair

TO: _____ Date _____
 _____ Re: _____

 ATTN: _____

- We are sending you Attached Under separate cover via _____ the following items:
 Shop Drawings Prints Drawings Samples Specifications
 Copy of Letter Change Order _____

Copies	Date	No.	Description

These are transmitted as checked below:

- For Approval Approved as Submitted Resubmit _____ Copies for Approval
 For Your Use Approved as Noted Submit _____ Copies for Distribution
 As Requested Returned for Corrections Return _____ Corrected Prints
 For Review and Comment _____

Remarks: _____

By: _____

- Distribution: Owner
 Contractor
 Construction Manager
 Design Professional
 Consultant
 Other



SUBSTITUTION REQUEST

Project Number 60800073

Project Title Water Department Emergency Transmission Water Main Repair

To: _____

Authorization Number: _____

Re: _____

From: _____

Date: _____

Contract For: _____

Specification Title: _____

Section: _____ Page: _____ Article/Paragraph: _____

Proposed Substitution: _____

Manufacturer: _____ Address: _____ Phone No. _____

Trade Name: _____ Model No. _____

Installer: _____ Address: _____ Phone No. _____

History: New Product 2-5 years old 5-10 years old More than 10 years old

Differences between proposed substitution and specified product: _____

Point-by-point comparative data attached – REQUIRED

Undersigned certifies:

- Proposed substitution has been fully investigated and determined to be equal or superior in all respects to specified product.
- Same warranty will be furnished for proposed substitution as for specified product.
- Same maintenance, service, and availability of replacement parts, as applicable, are available.
- Proposed substitution will not affect or delay Progress Schedule, except as stated below.
- Cost data as stated above is complete. Claims for additional costs related to accepted substitution which may subsequently become apparent are to be waived.
- Proposed substitution does not affect dimensions and functional clearances, except as stated below.
- Payment will be made for changes to building design, including architectural or engineering design, detailing, licenses, royalties, and construction costs caused by the requested substitution.
- Coordination, installation, and changes in the Work as necessary for accepted substitution will be completed in all respects.

Reason for not providing specified item: _____

Similar Installation:

Project: _____

Design Professional: _____

Address: _____

Owner: _____

Date Installed: _____

Proposed substitution affects other parts of Work: No Yes; explain _____

Savings to Owner for accepting substitution: _____

Proposed substitution changes Contract Time: No Yes; add/deduct _____ days.

Supporting Data Attached:

Product Data Drawings Tests Reports Samples _____

Attachments: _____

Submitted by: _____

Signature: _____

Firm: _____

Address: _____

Telephone: _____ Fax: _____ E-Mail: _____

Additional Comments: Contractor Subcontractor Supplier Manufacturer DP _____

DESIGN PROFESSIONAL'S REVIEW AND ACTION

- Substitution approved – Make submittals in accordance with Specification Section 01300.
- Substitution approved as noted – Make submittals in accordance with Specification Section 01300.
- Substitution rejected – Use specified materials.
- Substitution Request received too late – Use specified materials.

Signed by: _____ Date: _____

Distribution:

- Owner
- Design Professional
- Contractor
- Consultant
- Construction Manager
- Other

SECTION 01700
TRAFFIC REGULATIONS

PART 1 GENERAL

1.1 Section Description

- A. This section provides for the control and maintenance of traffic areas throughout the Work.

1.2 Section Includes

- A. Notification
- B. Maintenance of Traffic
- C. Traffic Control
- D. Signs
- E. Vehicle Parking
- F. Flagmen
- G. Lights
- H. Haul Routes
- I. Street Closure

1.3 Related Sections

- A. Section 01000 – General Requirements
- B. Section 01300 – Submittals

1.4 Notification

- A. Advance written notice of construction activity shall be made to all adjacent residents no less than forty-eight (48) hours, or more than seventy-two (72) hours, before construction begins.
- B. The notice shall describe the activity anticipated in that area, the duration, and the effects upon the residents (such as restricted parking).
- C. The Contractor's on-site contact person, address, and direct telephone number shall be included, in addition to a contact person from City.

1.5 Maintenance of Traffic

- A. Traffic shall be maintained through construction, in accordance with the City of Kansas City, Public Works Department Standard Details and the Missouri Department of Transportation (MoDOT) requirements within state right-of-way.
- B. The Contractor is responsible for maintaining traffic.
- C. The Contractor shall conduct his work so as to minimize interference with traffic, vehicular or pedestrian.
- D. A permit is required from the KCMO Public Works Department, Street and Traffic Division for areas where traffic will be obstructed in Kansas City, Missouri and from MoDOT for areas within MoDOT right-of-way. Contractor shall prepare traffic control plans for the Work and submit to KCMO and MoDOT for traffic control permits.
- E. When necessary to cross or interfere with traffic the Contractor shall provide and maintain suitable and safe bridges, detours, or other temporary expedients for the accommodation of public and private travel. Contractor shall give at least twenty-four (24) hours notice to owners of private drives before interfering with them.
- F. Contractor shall seek approval from MoDOT for any lane closures on state routes. The lane closure request and temporary traffic control plan shall be submitted to MoDOT for review and approval at least two working days prior to the planned closure.

1.6 Traffic Control

- A. General
 - 1. All streets, roads, highways, and other public thoroughfares that are to be temporarily closed or restricted to traffic shall be protected by effective barricades on which shall be placed acceptable warning signs. Barricades shall be located at the nearest intersecting public highway or street on each side of the blocked section.
 - 2. All open trenches and other excavations shall be covered with steel plates and have suitable barricades, signs, and lights to provide adequate protection to the public. Obstructions such as material piles and equipment shall be provided with similar warning signs and lights.
 - 3. All barricades and obstructions shall be illuminated with warning lights from sunset to sunrise. Material storage and performance of the Work on or alongside public streets and highways shall minimize obstruction and inconvenience to the public.
 - 4. All barricades, signs, lights, and other protective devices shall be installed and maintained in conformity with applicable statutory requirements and, where within railroad and highway rights-of-way, as required by the authority having jurisdiction.

5. Working hours on traveled roadways or within the clear zone are typically limited to 9:00 a.m. to 4:00 p.m. Monday through Friday. However, due to the proximity of schools and high volume of traffic additional restrictions on working hours may be required by the KCMO Public Works Department or MoDOT. Contractor shall schedule work around working hour restrictions.
6. The Contractor shall maintain a minimum of one lane of traffic in all directions at all times. No more than 660 feet of lane length can be restricted at a single time unless otherwise specified in the traffic control permit.

B. Devices:

1. Contractor shall provide all barricades, cones, construction warning signs, flagmen, and incidental devices to protect personnel and equipment on the Work site.
2. Contractor shall display the required signs. Traffic control devices not in use shall be covered, removed, or turned away from view of oncoming traffic. Whenever the work area changes, all construction warning signs and traffic channelization devices shall be made current in both legend and function.
3. Contractor shall provide "Temporary Traffic Control" that is in accordance with the minimums set forth in the "Manual on Uniform Traffic Control Devices for Streets and Highways" (MUTCD) - Current Edition. Substitutions for the required devices and methods will only be allowed with the written approval of the KCMO Public Works Department, Street and Traffic Division or MoDOT.

C. Non-work hours:

1. During non-work hours all roadways shall be opened to normal traffic.
2. Construction equipment or materials shall not interfere with traffic during non-work hours. Barricades (barrels, type I) equipped with appropriate warning lights shall be placed adjacent to the work area. Construction signs, except "ROAD CONSTRUCTION AHEAD" signs, shall be covered or turned from view of oncoming traffic.

1.7 Signs

A. No Parking:

1. "Emergency No Parking" signs may be installed at locations approved by KCMO Public Works Department or MoDOT within state right-of-way.
2. Signs shall be in accordance with the KCMO Public Works "Standard Signs for Traffic Maintenance During Construction" or MoDOT requirements. Signs shall be on aluminum or plywood panels. Paper or cardboard signs will not be allowed. Signs must be installed a minimum of eighteen (18) hours prior to beginning Work. The Contractor must contact the Public Works Dispatcher (816-513-9300) as soon as the signs are installed so that the KCMO Police

Department can be notified. The signs cannot be enforced without this notification to City and KCMO Public Works Department.

3. Signs shall be installed on either steel driven posts or existing utility poles at a height of five (5) feet from the bottom of the sign. The signs are to be installed at 150-foot intervals. The Contractor shall immediately remove all signs and covers as soon as work has been completed. If work will cease for more than seventy-two (72) hours, the signs and covers shall be removed and reinstalled subject to the minimum eighteen (18) hours notice.

1.8 Vehicle Parking

- A. Parking of construction vehicles and personal vehicles of Contractor's personal shall not interfere with public traffic and parking, access by emergency vehicles, and City operations.

1.9 Flagmen

- A. Contractor shall provide trained and equipped flagmen to regulate traffic when construction operations or traffic encroach on public traffic lanes.

1.10 Lights

- A. Contractor shall use lights during hours of low visibility to delineate traffic lanes and to guide traffic.

1.11 Haul Routes

- A. Contractor shall consult with City and KCMO Public Works Department or MoDOT within state right-of-way to establish public thoroughfares to be used for haul routes and site access.

1.12 Street Closure

- A. Contractor shall obtain a Street Closure Permit in advance of a proposed closure date.

PART 2 PRODUCTS

1. Not Used

PART 3 EXECUTION

3.1 Coordination

- A. Damages:
 1. Damage to existing roads and utilities during the Work that requires immediate repair may be considered an "emergency". Therefore, Contractor shall immediately contact the utility, the KCMO Public Works Department,

Street and Traffic Division or MoDOT within state right-of-way whenever there is damage that may require immediate repair. Such repair work once declared an “emergency” will be pursued on a continuous (around the clock) basis until complete or advanced to such a point that use of the roadway can be returned to normal operation and any subsequent repairs completed during normal working hours.

B. Adjustments:

1. The KCMO Public Works Department, Street and Traffic Division or MoDOT within state right-of-way reserves the right to make adjustments or revisions in traffic handling requirements that may become necessary after the Work has started. These changes will be determined on the basis of periodic inspections throughout the duration of the Work.
2. Notice of such change will be transmitted to the Contractor and it will be his responsibility to make the necessary changes as soon as practicable after receipt of the notification.

3.2 Inspections and Maintenance

A. Inspections:

1. The Contractor shall make periodic inspections of the traffic control devices installed as part of Work and shall maintain record of any maintenance required. These records will be maintained throughout the Work and be incorporated as part of the final records.
2. The Contractor shall make daily inspections of the traffic control devices installed.

B. Maintenance:

1. Contractor shall be required to designate a specific employee to be responsible for the maintenance of the traffic control devices and establish a method of contacting this person. This information shall be provided to City, the KCMO Public Works Department, Street and Traffic Division, and MoDOT, in writing prior to the start of work.
2. Contractor may, at his option, establish a maintenance agreement with a qualified firm, approved by City, to supply, install and maintain the required traffic control devices throughout the duration of the Work.
3. Whenever the work area changes, all construction warning signs and traffic channelization devices shall be made current in both legend and function.
4. The roadway shall be kept clean and free of construction related debris at all times.

3.2 Payment

- A. No separate payment will be made for the Traffic Control Permits or the maintenance or control of traffic. Contractor shall include in his Total Bid Price all labor, materials, and equipment for the maintenance and control of traffic for his Work and permit costs.

END OF SECTION

SECTION 02200
EXCAVATION AND BACKFILL

PART 1 GENERAL

1.1 Section Description

- A. This section describes the procedures and soil material to be used with excavation, trenching, embedment, and backfill.

1.2 Section Includes

- A. Granular Fills
- B. Embedment
- C. Backfill
- D. Filter Fabric
- E. Groundwater Barrier Material
- F. Topsoil
- G. Fills and Embankment Material

1.3 Related Sections

- A. Section 01016 – Water Mains Near Sewers
- B. Section 01300 – Submittals
- C. Section 01600 – Materials and Equipment
- D. Section 02575 – Surface Restoration

1.4 References

- A. ASTM C33 - Standard Specifications for Concrete Aggregates
- B. ASTM D698 - Test Method for Laboratory Compaction Characteristics of Soil Using - Standard Effort (12,400 ft-lb./ft)
- C. ASTM D1557 - Test Methods for Laboratory Compaction Characteristics of Soil Using - Modified Effort (56,000 ft-lb./ft)
- D. ASTM D3776 - Standard Test Methods for Mass Per Unit Area (Weight) of Fabric

- E. ASTM D4253 - Standard Test Methods for Maximum Index Density and Unit Weight of Soils Using a Vibratory Table
- F. ASTM D4254 - Standard Test Method for Minimum Index Density and Unit Weight of Soils and Calculation of Relative Density
- G. ASTM D4632 - Standard Test Method for Grab Breaking Load and Elongation of Geotextiles

1.5 Submittals

- A. Follow the procedures for submittals provided in Section 01300 - Submittals.
- B. Submit gradation test reports and quarry quality control reports for the following materials:
 - 1. Granular Fill
 - 2. Granular Embedment
 - 3. Graded Gravel Backfill
- C. Submit a Filter Fabric Manufacturer's Data listing the average values of the properties specified herein.

1.6 Quality Assurance

- A. In accordance with OSHA "Safety and Health Regulations for Construction", Chapter XVII of Title 29, CFR, Part 1926, and the Contractor shall employ a competent person and, when necessary, a registered professional engineer, to act upon all pertinent matters of the work of this section.
- B. Backfilling and construction of fills and embankments during freezing weather shall not be done except by permission of the WSD. No backfill, fill, or embankment materials shall be installed on frozen surfaces, nor shall frozen materials, snow, or ice be placed in any backfill, fill, or embankment.

1.7 Delivery, Storage, and Handling

- A. Follow the procedures for the delivery, storage, protection and handling products to and at site provided in Section 01600 - Material and Equipment.
- B. Store and secure materials in neat stockpiles in locations that do not inconvenience public and WSD operations.
- C. Comply with manufacturers recommendations for storage.

PART 2 PRODUCTS

2.1 Materials

A. Granular Fills:

- A. Granular Fill material shall be clean crushed rock or gravel; free from dust, clay, and trash; and graded 1-1/2 inch to No. 4 as defined in ASTM C33.
- B. **Type 5 Aggregate:** Type 5 aggregate shall consist of crushed stone or sand and gravel. The aggregate shall not contain more than 15 percent deleterious rock and shale. If crushed stone is used, sand may be added only for the purpose of reducing the plasticity index of the fraction passing the no. 40 sieve in the finished product. The fraction passing the No. 40 sieve shall have a plasticity index not to exceed six. Any sand, silt and clay and any deleterious rock and shale shall be uniformly distributed throughout the material. When sand and gravel aggregate is used, the fraction passing the No. 200 sieve shall be less than 1/2 that of the fraction passing the No. 30 sieve.

Type 5 Aggregate shall conform to the following gradation requirements and in addition shall be so graded that the aggregate will readily compact to the specified density and withstand construction traffic without distortion and displacement.

Sieve Size	Percent Passing by Weight
1 inch	100
1/2 inch	60 - 90
No. 4	40 - 60
No. 30	15 - 35
No. 200	0 - 15

C. Embedment:

- 1. Granular Embedment: Granular embedment shall be clean crushed rock with not less than 95% passing a 1/2" screen and not more than 5% passing a #4 screen.
- 2. Embedment material shall not contain cinders, clay lumps, or other materials that may cause pipe corrosion.

D. Backfill:

- 1. Compacted Backfill (under non-paved areas): Compacted backfill may be suitable job excavated material or graded gravel, as described below:
 - a. Job Excavated Material: Job excavated material may be used for compacted backfill when the job excavated material is finely divided and free from debris, organic material, cinders, any corrosive material, and stones larger than 3 inches in greatest dimension. Masses of moist, stiff clay shall not be used.

- b. Graded Gravel Backfill: Gravel for compacted backfill shall be clean and conform to the following gradation. The gravel mixture shall contain no clay lumps or organic matter. The fraction passing the No. 4 sieve shall have a liquid limit not greater than 25 and a plasticity index not greater than 5.

Sieve Size	Percent Passing by Weight
1 inch	100
3/4 inch	85 – 100
3/8 inch	50 – 80
No. 4	35 – 60
No. 40	15 – 30
No. 200	5 – 10

E. Filter Fabric:

1. Nonwoven fabric consisting of only continuous chains of polymeric filaments or yarns of polyester formed into a stable network by needle punching. The fabric shall be inert to commonly encountered chemicals; shall be resistant to mildew, rot, ultraviolet light, insects, and rodents; and shall have the following properties:

Property	Test Method	Unit	Minimum Average Roll Value (weakest principal direction)
Fabric Weight	ASTM D3776	Oz/yd ²	4.5
Grab Strength	ASTM D4632	lb.	120
Grab Elongation	ASTM D4632	Percent	60
Mullen Burst Strength	ASTM D3776	Psi	190
Apparent Opening Size	CW-02215	U.S. Standard Sieve Size	70

2. Filter fabric shall be provided in rolls wrapped with protective covering to protect the fabric from mud, dirt, dust, and debris.

F. Groundwater Barrier Material:

1. Finely divided material free from stones, organic matter and debris meeting soil classification GC, SC, CL or ML-CL. Job excavated material may be used if suitable.

G. Topsoil:

1. Topsoil: Naturally occurring gray or black fertile soil material containing humus, high in nutrients, free of large roots, rocks larger than 1/2 inch, subsoil, debris, large weeds and foreign matter.

H. Fills and Embankment Material:

1. All material placed in fills and embankments shall be free from rocks or stones larger than 6 inches in their greatest dimension, brush, stumps, logs, roots, debris, and other organic or deleterious materials. No rocks or stones shall be placed in the upper 18 inches of any fill or embankment. Rocks or stones within the allowable size limit may be incorporated in the remainder of fills and embankments, provided they are distributed so that they do not interfere with proper compaction. Job excavated material meeting their requirements may be used.

PART 3 EXECUTION

3.1 General Guidelines

- A. Excavations shall be restored to the level of the adjacent surfaces as soon as practicable. Unsupervised open excavations on public properties, including easements are not permitted. Any person involved with open excavation on public properties shall provide effective protection to the public.
- B. Excavations in roadways shall be protected and secured in accordance with existing federal, state and local codes and standards, including, but not limited to, the most current edition of the Manual of Uniform Traffic Control Devices.
- C. Unsupervised excavations not within roadways shall be protected and secured. A protective cover over an excavation shall be installed so that it can sustain the weight of any persons and/or objects placed upon it. The cover shall be fixed to the ground so it cannot be moved. Protective covers shall have no opening(s) or protuberance(s) of sufficient size to cause a fall and/or injury. Advance warning devices shall be installed as necessary.
- D. Any excavation that is not covered shall be fenced in so that it surrounds the entire excavation area and prevents entry. The fencing shall be a minimum of 42" in height. The fence shall be secured and upright at all times.
- E. Protective excavation coverings and fences shall be inspected by the Contractor at least daily to assure integrity. Protective excavation coverings and fences in heavy traffic areas shall be inspected more often as necessary.
- F. Permits shall be secured prior to any work on public properties. In all instances the Contractor agrees to perform all work in accordance with the permit and to indemnify and hold harmless the City from all liability, judgments, costs, expenses and claims growing out of damages or alleged damages, of any nature to any person or property arising out of performance or non-performance of said work or the existence of facilities and/or appurtenances thereof.

3.2 Surface Preparation

A. Clearing:

1. Tag or identify existing trees, shrubs, and landscape materials to be removed, and obtain WSD approval prior to removal.
2. Protect existing trees, plant life, and features that are to remain from damage by construction operations.
3. Open burning of brush or debris will not be permitted unless the Contractor obtains a permit for open burning of trade wastes from the KCMO Environmental Health Division, Air Quality Program Manager.
4. Dispose of all cleared and grubbed materials.

B. Cutting Portland Cement Concrete Curbs and Pavement:

1. Cuts in curbs and pavements shall provide the minimum working space for proper installation of pipe and appurtenances. Utilize a concrete saw to cut a clean groove to a minimum depth of 3 inches.
2. Curbs and concrete pavement excavated for pipelines shall be removed so that a shoulder not less than 12 inches in width at any point is left between the cut edge of the pavement and the top edge of the trench. Trench width at the bottom shall not be greater than at the top and no undercutting will be permitted.
3. Where the trench parallels the length of curbs or sidewalks, and the trench location is all or partially under the curb or walk, the entire structure shall be removed and replaced. Where the trench crosses surface construction (walks, curbs, etc.) the structures shall be removed and subsequently replaced between existing joints or between saw cuts. Pipeline crossings at existing concrete driveways shall not be open cut unless approved by WSD.

3.3 Trench Excavation

A. General:

1. Classification of excavated materials is not permitted. Excavation and trenching work shall include the removal and handling of all materials necessary to place the pipeline and appurtenances at the line and grade on the drawings, regardless of the type, character, composition, or condition of the material.
2. No more trenches shall be opened than is necessary to expedite the Work. Except where tunneling is required, all trench excavation shall be open cut from the surface.

B. Depth of Excavation:

1. Trenches shall be excavated to a depth sufficient to provide a minimum depth of 42" backfill cover over the top of the pipe as indicated below. Sixteen inch and larger diameter water lines shall be provided a minimum of 60" backfill cover. Greater pipe cover depths may be necessary on vertical curves or to provide necessary clearance beneath existing pipes, conduits, drains, drainage structures, or other obstructions.
2. Pipe cover depth shall be measured vertically from the outside top of pipe to finished ground or pavement surface elevation.

C. Trench Bottoms in Rock:

1. Rock excavations shall be carried to a minimum of six (6) inches below the bottom of the pipe. Granular embedment material as specified in this section and as shown in the Construction Detail Drawings shall be used to restore the trench bottom to the desired elevation and grade and to provide a uniform bearing and continuous support for the pipe along its entire length.
2. Prevent any portion of the pipe from coming to bear on solid rocks or boulders.

D. Blasting:

1. Blasting or other use of explosives for excavation will not be permitted without obtaining a blasting permit from the KCMO Public Works Department and KCMO Fire Department.
2. Contractor shall provide a plan for pre-blast surveys, monitoring during blasting, and post blast surveys to WSD prior to use of explosives.
3. All existing safety regulations, laws, and ordinances on the storage, transportation, and use of explosives shall be observed.
4. Blasting will be permitted only when proper precautions are taken for the protection of persons, the work, private property, public utilities, and the public from damage or injury. Any damage done by blasting will be repaired.

E. Limiting Trench Widths:

1. Trenches shall be excavated to a width that will provide adequate working space and sidewall clearances for proper pipe installation, jointing, and embedment. Trench widths shall be as follows:

TRENCH WIDTHS
Ductile Iron Pipe

Pipe Size	Min. Trench Width in Earth	Max. Trench Width in Earth	Max. Trench Width in Rock
4"	18"	24"	24"
6"	24"	30"	24"
8"	26"	32"	24"
12"	28"	34"	28"
16"	34"	40"	32"
20"	38"	44"	36"
24"	42"	48"	44"

F. Dewatering:

1. Obtain all necessary permits for the disposal of water from the excavation.
2. Provide and maintain all dewatering equipment to remove and dispose of all surface water and groundwater entering excavations, trenches, or other parts of the Work. Excavation shall be kept dry throughout the Work to ensure that no damage from hydrostatic pressure, flotation, or other cause will result.
3. All excavations for concrete structures or trenches that are within 12 inches of groundwater or extend below groundwater shall be dewatered 12 inches or more below the bottom of the excavation.
4. Prevent surface water from entering excavations or trenches and causing damage to adjacent property.
5. The Contractor shall be responsible for the condition of pipe or conduit including storm sewers, used for drainage.

G. Sheet piling and Shoring:

1. Except where banks are cut back on a stable slope, excavations for structures and trenches shall be supported to prevent caving or sliding.
2. Trench sheet piling may be removed only if the pipe strength is sufficient to carry trench loads based on trench width to the back of sheet piling. Unless approved by the WSD, trench sheet piling shall not be pulled after backfilling.
3. Where trench sheet piling is left in place, sheet piling shall not be braced against the pipe, but shall be supported in a manner that will preclude concentrated loads or horizontal thrusts on the pipe. Cross braces installed above the pipe

to support sheeting may be removed after pipe embedment has been completed.

H. Subgrade Stabilization:

1. Subgrades for trench bottoms shall be firm, dense, and thoroughly compacted and consolidated; free from mud and muck; and shall remain firm and intact under the feet of the workers.
2. Subgrades for trench bottoms that are solid, but become mucky on top due to construction operations, shall be reinforced with clean crushed rock or gravel. The stabilizing material shall be spread and compacted to a depth of not more than 12 inches; the material shall be furnished and installed as specified for Granular Fills. The finished elevation of stabilized subgrades shall not be above subgrade elevations.
3. Soft areas of subgrade not capable of proper compaction shall be excavated and backfilled with granular fill material compacted to 95% modified Proctor per ASTM D4253 and D4254.

I. Mechanical Excavation:

1. The use of mechanical equipment will not be permitted in locations where its operation would cause damage to trees, buildings, culverts, or other existing property, utilities, or structures above or below ground. In all such locations, hand excavating methods shall be used.
2. Mechanical equipment used for trench excavation shall provide a smooth excavation bottom and alignment with the pipe centered in the middle of the trench with adequate sidewall clearance. Undercutting the trench sidewall to obtain sidewall clearance will not be permitted.

J. Excavation Below Pipe:

1. Trenches shall be excavated to a sufficient depth to provide for the installation of Embedment as indicated on Construction Detail Drawings No. 02200-1.

K. Bell Holes:

1. Bell holes shall provide adequate clearance for tools and methods used in installing pipe. No part of any bell or coupling shall be in contact with the trench bottom, trench walls, or granular embedment when the pipe is jointed.

L. Drainage Maintenance:

1. Trenches across areas adjacent to drainage ditches or watercourses shall not be backfilled prior to completion of backfilling the trench on the upstream side of the area, to prevent impounding water after the pipe has been laid. Bridges and other temporary structures required to maintain traffic across

unfilled trenches shall be constructed and maintained by the Contractor. Backfilling shall be done so that water will not accumulate in unfilled or partially filled trenches. Remove material deposited in roadway ditches or other watercourses crossed by the line of trench after backfilling is completed. Restore the original section, grades, and contours of ditches or watercourses. Surface drainage shall not be obstructed longer than necessary.

M. Stream Crossings:

1. Stream crossings shall be constructed as shown on the Drawings.
2. Pipe encasement, where required by the Drawings shall be in accordance with specification Section 02320 and Construction Detail Drawings.
3. The construction of riprap for erosion prevention of ditch slopes shall be as specified in Section 02273.
4. The Contractor shall furnish all labor, equipment, and materials, and perform all Work as required for shoring, forming, dewatering, trenching, backfilling, riprap, concrete or steel, or any other items necessary in constructing stream crossings.

3.4 Fills and Embankment

A. General:

1. Embankments or fill materials shall be placed where indicated on the Drawings.
2. Fill and embankment materials shall be placed in horizontal layers a maximum of eight (8) inches in thickness before being compacted. Material deposited in piles or windrows by excavating and hauling equipment shall be spread and leveled before compaction.
3. Each layer of material shall have the best practicable moisture content for satisfactory compaction. The material in each layer shall be wetted or dried as required and thoroughly mixed to ensure uniform moisture content and adequate compaction. Each layer shall be thoroughly compacted to 95 percent of maximum density at optimum moisture content as determined by ASTM D698.
4. Wherever a pipeline is to pass through a fill or embankment, the fill or embankment material shall be placed and compacted to an elevation not less than thirty-six (36) inches above the top of pipe elevation, and a trench shall be excavated in the embankment to permit placement of the pipe.
5. Granular Fills shall be provided where indicated on the Drawings. Granular Fills shall be placed on suitably prepared subgrades and compacted by

vibration. Granular Fills shall be compacted to not less than 95 percent relative density as determined by ASTM D1557.

6. Where pipes are installed in embankments containing ground water, granular embedment material shall normally be omitted and the trench bottom shall be graded to provide uniform and continuous support for the pipe. The pipe shall be embedded in embankment material containing no rocks or stones. The embedment material shall be compacted as specified for the embankment.

3.5 Embedment and Backfill

A. Pipe Embedment:

1. Embedment materials both below and above the bottom of the pipe, Classes of embedment to be used, and placement and compaction of embedment material shall conform to the requirements indicated on Figure 02200-1 and to the following supplementary requirements.
2. Embedment material shall contain no cinders, clay lumps, or other Material which may cause pipe corrosion.
3. All Embedment shall be Class A.
4. Placement and Compaction: Granular embedment material shall be spread and the surface graded to provide a uniform and continuous support beneath the pipe at all points between bell holes or pipe joints.
5. After each pipe has been aligned, placed in final position on the embedment material, and shoved home, sufficient pipe embedment material shall be deposited and compacted under and around each side of the pipe and back of the bell to hold the pipe in proper position and alignment during subsequent pipe jointing and embedment operations. Embedment material shall be deposited and compacted uniformly and simultaneously on each side of the pipe to prevent lateral displacement.
6. Granular Embedment shall be placed in maximum 6" layers and vibrated with a mechanical probe type vibrator during placement to ensure that all spaces beneath the pipe are filled. Each lift of embedment material shall be compacted with a platform type vibrating compactor to at least 70 percent relative density as determined by ASTM D4253 and D4254.
7. Groundwater Barrier: Interrupt continuity of embedment material by placing low permeability Groundwater Barrier Material to impede passage of groundwater through the embedment. Groundwater Barrier Material shall be placed around vault structures with cast-in-place bases and compacted to 95% of maximum density and along trenches at intervals approved by WSD not to exceed 250 feet.

- a. Groundwater Barriers (specified under pipe embedment) shall extend to the top of the graded gravel backfill.
- B. Trench Backfill: Compacted Backfill: Compacted Soil Backfill may be used above the granular embedment in non-paved areas.
- 1. Job Excavated Materials (in non-paved areas): Place in uniform layers not exceeding eight (8) inches in thickness before being compacted. Each layer of material shall maintain optimum moisture content for compaction. The material in each layer shall be wetted or dried as required and mixed to ensure uniform moisture content and compaction. Increased layer thickness not to exceed 12 inches in thickness before being compacted may be permitted for non-cohesive material if the Contractor demonstrates to WSD satisfaction that the specified compacted density will be obtained. The method of compaction and the equipment used shall be appropriate for the material to be compacted and shall not transmit damaging shocks to the pipe. Job excavated material shall be compacted to 95 percent of maximum density at optimum moisture content, as determined by ASTM D698, or to 70 percent relative density, as determined by ASTM D4253 and D4254 when appropriate.
 - 2. Type 5 Aggregate Backfill: Place in uniform layers not exceeding twelve (12) inches in thickness before being compacted. The backfill shall be compacted with a vibratory roller or platform vibrator to at least 70 percent relative density as determined by ASTM D4253 and D4254.

3.6 Final Grading and Placement of Topsoil

- A. After completing backfilling, grade areas to the required elevations, slopes, and contours. All cuts, fills, embankments, and other areas that have been disturbed or damaged by construction operations shall be surfaced with topsoil to a depth of at least 4 inches.
- B. Use of graders or other power equipment will be permitted for final grading and dressing slopes. Grade surfaces to provide effective drainage. Unless otherwise indicated, provide a slope of at least 1- percent.
- C. Final grades and surfaces shall be smooth, even, and free from clods and stones, weeds, brush, and other debris.

3.7 Disposal of Excess Materials

- A. Excess excavated materials that are not utilized in trench backfill shall be disposed of at an approved site or landfill.
- B. Excess earth from excavations may be distributed directly over the pipe trench and within the pipeline right-of-way to a maximum depth of 6 inches above the original ground surface elevation along the trench centerline and sloping each way. Wasted material shall be carefully finished with a drag, blade machine, or other

suitable tool to a smooth, uniform surface without obstructing drainage. Wasting of excess excavated material as described will not be permitted where the line of trench crosses or is within a railroad, public road, highway right-of-way or established lawn or other landscaped area. The disposal of waste and excess excavated materials, including hauling, handling, grading, and surfacing, shall be an obligation of the Contractor.

3.8 Maintenance

- A. The Contractor shall be responsible for all settlement of backfill, fills, and embankments that may occur.

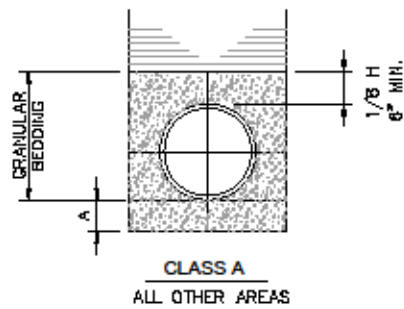
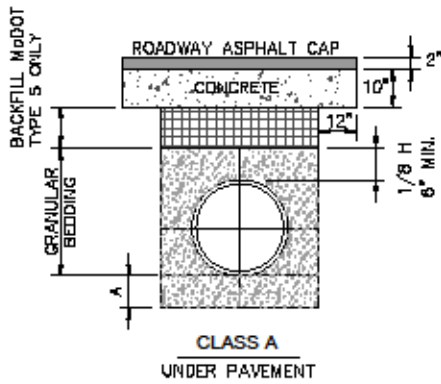

END OF SECTION



NOTES

FOR EMBEDMENT AND BACKFILL SPECIFICATIONS AND ASSOCIATED COMPACTION REQUIREMENTS SEE SECTION 02200.

LEGEND

-  GRANULAR BEDDING
-  BACKFILL
-  MODOT TYPE 5 AGGREGATE FOR BASE

ABBREVIATIONS

- H COVER ABOVE TOP OF PIPE
- A DEPTH OF EMBEDMENT BELOW 20" AND SMALLER PIPE (MINIMUM IN SOIL SHALL BE 3"; MINIMUM IN ROCK SHALL BE 6")

**EMBEDMENT AND BACKFILL FOR ALL PIPES
REQUIRES CLASS A EMBEDMENT**

WATER SERVICES DEPARTMENT

CITY OF KANSAS CITY, MISSOURI

REVISED: AUGUST, 2016 CONSTRUCTION DETAIL DRAWING NO. 02200-1

SECTION 02320

UTILITY CASINGS - WATER MAIN CONSTRUCTION

PART 1 GENERAL

1.1 Section Description

- A. This section provides for installation of casing pipe at locations shown on the Drawings to protect the water main from surface loadings.

1.2 Section Includes

- A. Steel Casing Pipe
- B. Reinforced Concrete Pipe (RCP) Casing Pipe
- C. FRP Casing Pipe
- D. Accessories
- E. PVC Casing Pipe near gas mains

1.3 Related Sections

- A. Section 01300 – Submittals
- B. Section 01600 – Materials and Equipment
- C. Section 02200 – Excavation and Trenching
- D. Section 02618 – Ductile Iron Pipe Water Main
- E. Section 02669 – Thrust Restraints

1.4 References

- A. API RP1102 - Recommended Practice for Liquid Petroleum Pipelines Crossing Railroads and Highways.
- B. API 1104 - Standard for Welding Pipelines and Related Facilities.
- C. ASTM A36 - Structural Steel.
- D. ASTM A570 - Hot-Rolled Carbon Steel Sheet and Strip, Structural Quality.
- E. ASTM C33 - Standard Specifications for Concrete Aggregates.
- F. ASTM C76 - Standard Specifications for Reinforced Concrete Culvert, Storm Drain, and Sewer Pipe.

- G. ASTM C361 - Standard Specifications for Reinforced Concrete Low-Head Pressure Pipe.
- H. AWWA C200 - Steel Water Pipe 6 Inches and Larger.
- I. AWWA C206 - Field Welding of Steel Water Pipe.
- J. SSPC SP3 - Power Tool Cleaning.
- K. AWWA C900 and C-905 – Polyvinylchloride Pipe

1.5 Submittals

- A. Follow the procedures for submittals provided in Section 01300 – Submittals.
- B. Submit descriptive and engineering data for:
 - 1. Casing pipe material, coatings and linings.
 - 2. Pipe alignment skids.
 - 3. Guide spacer bands.
 - 4. Restrained casing spacers.
 - 5. End seals.

1.6 Delivery, Storage, and Handling

- A. Follow the provisions for the delivery, storage, protection and handling projects to and at site provided in Section 01600 - Material and Equipment.
- B. Accept piping on site. Inspect for damage and inventory.

PART 2 PRODUCTS

2.1 Materials

- A. Steel Casing Pipe:
 - 1. New, smooth wall, welded steel pipe fabricated from ASTM A36 plate or ASTM A570 sheet with a minimum yield point of 248 MPa (36,000 psi), conforming to AWWA C200.
 - 1. Casing Thickness: Contractor shall provide casing pipe with a diameter and wall thickness as shown on the Contract Drawings but not less than the following minimum diameter and thickness per encased pipe diameter:

2. **Minimum Casing Diameters**

Encased Pipe Diameter (inches)	Minimum Casing Diameter (inches) ⁽¹⁾	Wall Thickness (inches)	
		Under Highways	Under Railroads
6	18	0.250	0.312
8	18	0.250	0.312
12	24	0.281	0.375
16	30	0.312	0.438
20	36	0.344	0.563
24	42	0.375	0.625
30	44	0.375	0.625

(1) Minimum casing inside diameter shall exceed outside diameter of carrier pipe joints or couplings by 4 inches.

3. Joints: All joints in steel pipe casings shall be field welded to conform to API 1104 or AWWA C206.
 - a. Clean to SSPC-SP3 and apply iron oxide field coating to all exterior joints after field welding.
 - b. Clean to SSPC-SP3 and apply iron oxide field coating to all interior joints on 24 inch diameter casings and larger after field welding.
4. Factory Coatings and Linings: Coat exterior and line interior of all casing pipe with iron oxide primer applied at 33 microns (1.5 mils) minimum thickness. Hold coatings and linings back from end joints to be welded at least 2 inches each side of joint.

B. Reinforced Concrete Pipe (RCP) Casing Pipe:

1. Pipe: ASTM C76 circular pipe of the strength class required by the drawings, or the highway, railroad, or utility having jurisdiction.
2. Joints: Steel end joints with a groove in the spigot end for an O-ring gasket.
3. Gasket: Synthetic Rubber, ASTM C361.

C. Fiberglass Reinforced Pipes:

1. Pipe to be manufactured by the centrifugal casting process to result in a dense, nonporous, corrosion-resistant, consistent composite structure conforming to ASTM D3262, ASTM D 4161, and ASTM D2412.
2. Joints: Unless otherwise specified, the pipe shall be field connected with fiberglass sleeve couplings that utilize elastomeric sealing gaskets made of EPDM rubber compound as the sole means to maintain joint water tightness. The joints must meet the performance requirements of ASTM D4161.

3. The actual outside diameter and the minimum wall thickness of the pipes shall be in accordance with ASTM D3262. Pipe shall be supplied in nominal lengths of 20 feet. Minimum Pipe stiffness when tested in accordance with ASTM D2412 shall normally be 36 psi.

D. Accessories

1. Casing spacers: shall be used to install the carrier pipe inside the encasement pipe. Casing spacers shall fasten tightly onto the carrier pipe so that when the carrier pipe is being installed the spacers will not move along the pipeline. Casing spacers shall be doubled on each end of the encasement.

Each casing spacer shall be capable of providing support for the carrier pipe in service at a maximum spacing of 10'. Calculations shall be provided to the ENGINEER by the casing spacer manufacturer showing that the casing spacer will support the service load at the recommended spacing, including a factor of safety of two (2). Casing spacers used under this specification shall meet or exceed the specifications described herein as projection-type that has a minimum of projections around the circumference totaling the number of diameter inches.

Projection-type casing spacers panels, risers and fasteners shall be constructed of Stainless Steel type 304. Casing spacer skids shall be constructed of UHMV Polyethylene. Projection-type casing spacers shall be Power Seal Model 4810 or approved equal.

B. End Seals: Power Seal Model 4810ES or approved equal.

C. Sand: Clean, natural sand in accordance with ASTM C33.

E. PVC Casing Pipe near gas mains

1. When a water main will cross under or over, or is in close proximity to a gas main with an impressed current cathodic protection system the water main shall be placed inside a PVC casing pipe conforming to AWWA C-900 or AWWA C-905 for a distance of at least 10' each side of the gas main being crossed.

The water main shall also be protected by two layers of polyethylene encasement for a minimum distance of 25' each side of the gas main being crossed or for the full length of any water main paralleling within 10' of the gas main, or as indicated on the Drawings. Install in accordance with Construction Detail Drawing 02320-2.

2.2 Quality Assurance

- A. Contractor: Company specializing in the installation of the Products specified in this Section with minimum three years documented experience.

PART 3 EXECUTION

3.1 Installation

- A. All work shall meet the minimum requirements of API RP1102, and the highway, railroad, or utility having jurisdiction. Installation shall be subject to their inspection and approval.
- B. Install Casing Pipes:
 - 1. Boring: Continuous flight auger, pneumatic or hydraulic jacking, or method approved by WSD. Reinforce leading end of casing with jacking band.
 - 2. Install to line and grade indicated on the Drawings.
 - 3. Excavate working pits of adequate size to provide safe working conditions and in such a manner as not to disrupt traffic or damage the roadway grade or surface.
 - 4. Casings rejected due to misalignment or other failures shall be abandoned in place and filled with grout. Casing pipe shall not be recovered for reuse.

3.2 Casing Spacers

- A. Furnish casing spacers for pipe alignment guides as indicated on the Construction Detail Drawing No. 02320-1 for all carrier pipe to be installed in casing.
 - 1. Outside diameter of spacer to be sized slightly smaller than casing pipe inside diameter to limit carrier pipe movement.
 - 2. Install in accordance with spacer manufacturer's recommendations.

3.3 End Seals

- A. Install end seals as indicated on the Construction Detail Drawing No. 02320-1 and as follows:
 - 1. After inside of casing has been thoroughly cleaned.
 - 2. After carrier pipe has been permanently placed inside casing.

END OF SECTION

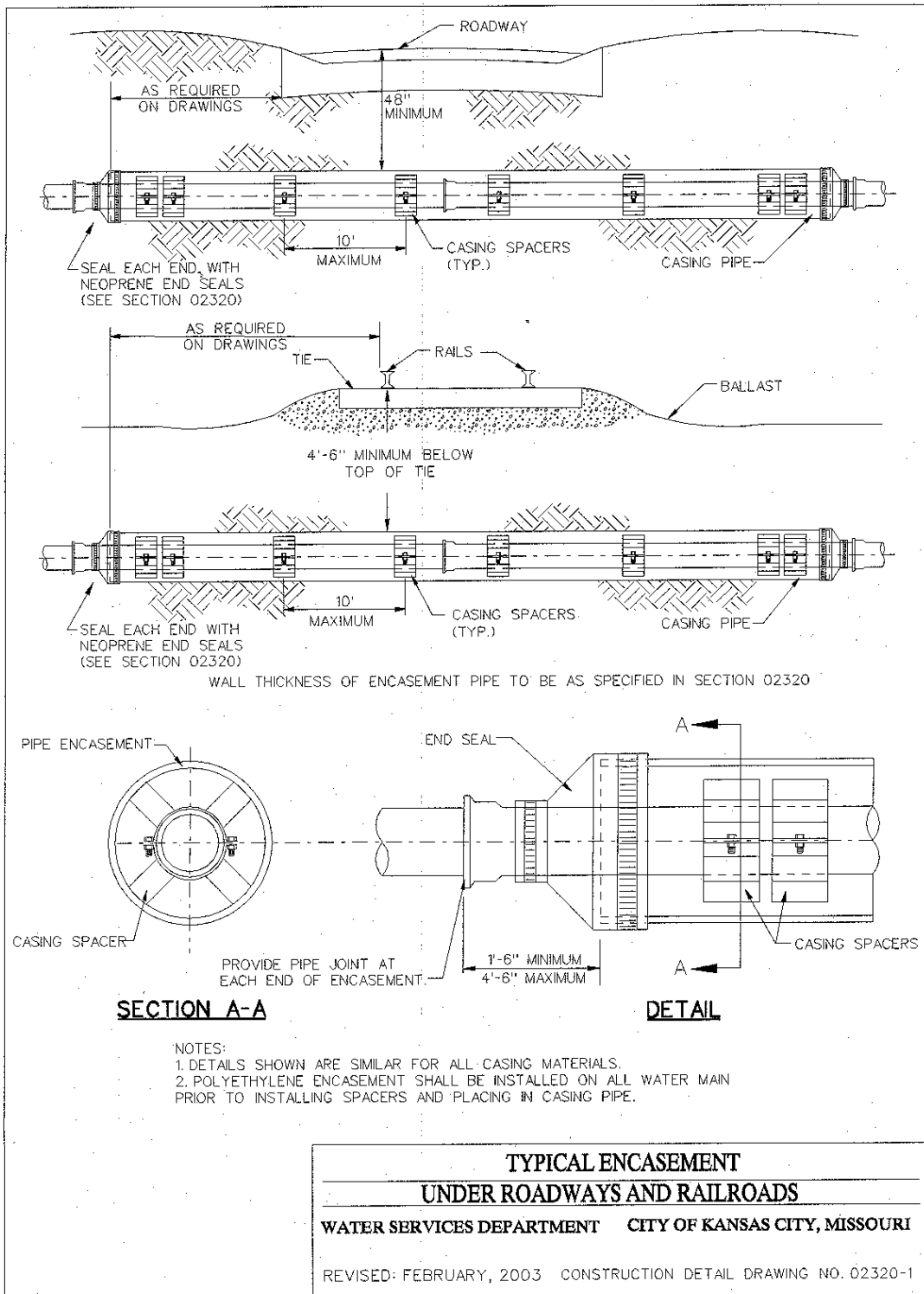

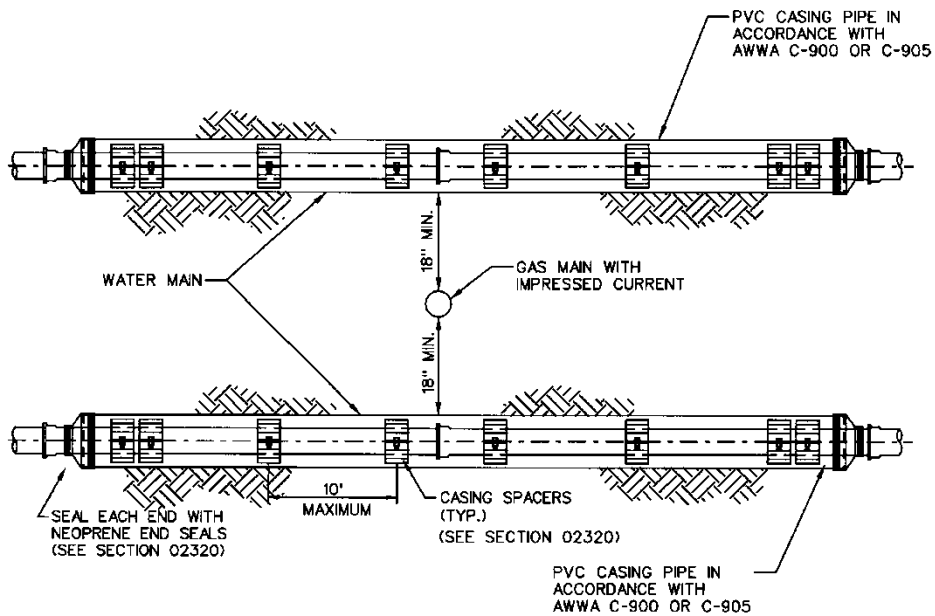

NOTES:

1. INSTALL DOUBLE THICKNESS OF POLYETHYLENE ENCASUREMENT ON WATER MAIN MINIMUM 25' EACH SIDE.
2. INSTALL CASING PIPE LENGTH REQUIRED TO EXTEND 10' EACH SIDE OF GAS MAIN.
3. MINIMUM DIAMETER OF CASING PIPE AS SHOWN IN TABLE, SECTION 02320 PART 2.

GAS MAIN / WATER MAIN CROSSINGS

WATER SERVICES DEPARTMENT CITY OF KANSAS CITY, MISSOURI

REVISED: JULY, 2006 CONSTRUCTION DETAIL DRAWING NO. 02320-2

SECTION 02575
SURFACE RESTORATION

PART 1 GENERAL

1.1 Section Description

- A. This section provides replacement of sidewalks, curbs, and pavement.

1.2 Section Includes

- A. Embedment and Backfill
- B. Roadway Surfacing
- C. Brick or other Paver Material
- D. Sidewalk

1.3 Related Sections

- A. Section 01300 – Submittals
- B. Section 01600 – Material and Equipment
- C. Section 02200 – Excavation and Trenching
- D. Section 03001 – Concrete

1.4 References

- A. American Public Works Association (APWA) - Standard Specifications.
- B. KCMO Public Works - Standard Specifications.
- C. Missouri Department of Transportation (MoDOT) Standard Specifications.

1.5 Submittals

- A. Follow the procedures for Submittals provided in Section 01300 - Submittals.

1.6 Quality Assurance

- A. All work shall conform to the latest APWA Standard Specifications and KCMO Department of Public Works Standard Specifications and Detail Drawings. In addition, for work specifically within MoDOT right-of-way, all restoration shall comply with MoDOT specifications and requirements.

- B. Street cuts under Permit Work shall comply with KCMO Public Works Rules and Regulations for Excavation Permits. Excavations shall be protected at all times in accordance with Section 02200 and the Contract Documents.
- C. The manufacturer or supplier shall be a company specializing in the Products specified in this Section with minimum three years documented experience.
- D. All tests required for compliance with MoDOT or KCMO Public Works restoration standards and any permit condition shall be at Contractor's costs. Contractor shall coordinate sample collection and testing. Laboratory and test procedures shall be in accordance with KCMO Public Works standards within KCMO right-of-way and MoDOT standards within MoDOT right-of-way. Tests results shall be provided to the KCMO Public Works, the KCMO Water Services Department, and MoDOT, where applicable.

1.7 Delivery, Storage, and Handling

- A. Follow the provisions for the delivery, storage, protection and handling products to and at site provided in Section 01600 - Material and Equipment:
- B. Do not place asphalt when base surface temperature is less than 40° F (4° C), or surface is wet or frozen.

PART 2 PRODUCTS

2.1 Materials

- A. Embedment and Backfill: Refer to Specification Section 02200 - Excavation and Backfill - Water Main Construction. Within MoDOT right-of-way, backfill materials shall comply with MoDOT specifications and requirements.
- B. Roadway Surfacing: In accordance with KCMO Public Works Standard Specifications and Street Cut Restoration Standard Drawing, SR-1. For restoration within MoDOT right-of-way, all restoration materials shall comply with MoDOT specifications and requirements.
- C. Brick or other Paver Material: Match existing.

PART 3 EXECUTION

3.1 General Requirements

- A. All excavation within City right-of-way requires a permit from the KCMO Public Works Department and within State Highway right-of-way requires a permit from MoDOT.
- B. All street or roadway pavement, driveway pavement, surfaced parking areas, sidewalks, curb and gutters, or other similar features encountered during water main construction shall be carefully demolished in accordance with the requirements herein, to allow for proper reconstruction of the feature.

- C. Existing pavements shall be cut parallel or perpendicular to the direction of traffic. Cuts shall be made with a concrete saw or similar tool designed for cutting pavement with a minimum of damage to the area to remain. The edges of cuts shall be smooth and straight. If, after trench excavation, cuts are less than one foot from the top of the trench in any location, the pavement shall be cut again, and additional pavement shall be removed to allow for proper pavement repair.
- D. All features subject to traffic (vehicular or foot) are to be reopened either permanently or temporarily, at the earliest possible time, to minimize inconvenience to the users of the feature. Trenches are to be backfilled or plated whenever no work is being conducted in the traffic location.
- E. Any surface feature damaged by construction activities, whether in the location of a trench or not, shall be removed and restored in accordance with these requirements.

3.2 Examination

- A. During demolition, existing pavement wearing course, base, and sub-base conditions shall be carefully observed, and measured as necessary for proper duplication during restoration.
- B. During restoration, examine sub-base and base to verify proper moisture content and ability to support construction activities and imposed loads.
- C. Verify grades and elevations are correct.

3.3 Curbs, Sidewalks, Sidewalk Ramps, Driveways, Bicycle/Pedestrian Paths and Concrete Features

- A. Concrete features are to be removed to the nearest joint in the existing material, provided that it is at least one foot from the top of the trench after excavation.
- B. Reconstruct curbs to match adjoining materials and dimensions. Curbs and curb ramps shall meet KCMO Public Works Standards sections 2209 and 2301 and Drawing C, and shall comply fully with all requirements in this section and with the requirements of ADAAG Section 4.7. For restoration within MoDOT right-of-way, Contractor shall comply with MoDOT specifications and requirements.
- C. Reconstruct sidewalks and driveways to the current City standard or to match the existing materials and dimensions, whichever is the higher standard. Sidewalks and driveways shall meet KCMO Public Works Standards section 2301 and Drawings D1, D2, and D3, and shall comply fully with all requirements in this section and with the requirements of ADAAG Section 4.7. For restoration within MoDOT right-of-way, Contractor shall comply with MoDOT specifications and requirements.
- D. Stone curbs, brick pavers and similar materials shall be carefully removed by hand, preserved for reuse, and replaced to match the existing feature. A concrete cap extending one foot beyond the top of trench shall be placed over the trench beneath the pavers. This supporting trench cap shall be 10 inches thick in areas subject to vehicular traffic, and 6 inches thick in areas subjected to foot traffic only. A sand bed shall be provided where required to properly level and install pavers.

3.4 Asphaltic Concrete Surfaces

- A. Pavement shall be removed twelve (12) inches beyond the edge of the disturbed subgrade or pavement whichever is greater. If the excavation is within three (3) feet of an existing joint or cut, the surface shall be extended to that joint or cut.
- E. B. Restoration of street cuts shall conform to the City “Street Cut Restoration Standards”, Street Cut Restoration Standard Drawing SR-1, and the requirements of the street cut permit. . For restoration within MoDOT right-of-way, Contractor shall comply with MoDOT specifications and requirements.
- C. Restoration of parking lot, driveway, and similar surfaces shall match the existing surface or conform to current standard for the feature whichever standard is higher.

3.5 Gravel and other Surfaces

- A. Oiled crushed rock (chip and seal) surfaces shall be replaced with a minimum of 6 inches untreated compacted aggregate and 4 inches of Type 3 asphaltic concrete.
- B. Earth or crushed rock roads shall be restored with a minimum of 12 inches of untreated compacted aggregate over a trench cap as described above. The aggregate material shall closely resemble the original or surrounding material.
- C. All other surfaces shall be restored to match the surrounding surface, as directed by City.

END OF SECTION

SECTION 02608
CONCRETE VAULTS

PART 1 GENERAL

1.1 Section Description

- A. This section provides for the installation of vaults to house water main appurtenances in locations shown on the drawings.

1.2 Section Includes

- A. Concrete Vaults
- B. Lids and Frames
- C. Vault Configuration

1.3 Related Sections

- A. Section 01300 – Submittals
- B. Section 01600 – Material & Equipment
- C. Section 02200 - Excavation and Trenching
- D. Section 02575 – Surface Restoration
- E. Section 02618 – Ductile Iron Pipe Water Main
- F. Section 02641 – Valves

1.4 References

- A. ASTM A48 - Gray Iron Castings.
- B. ASTM C33 - Standard Specification for Concrete Aggregates.
- C. ASTM C150 - Standard Specification for Portland Cement.
- D. ASTM C207 - Standard Specification for Hydrated Lime for Masonry Purposes.
- E. ASTM C478 - Precast Reinforced Concrete Manhole Sections.
- F. ASTM C923 - Resilient Connectors Between Reinforced Concrete Manhole Structures, Pipes, and Laterals.
- G. International Masonry Industry All-Weather Council (IMIAC): Recommended Practices and Guide Specification for Cold Weather Masonry Construction.

1.5 Submittals

- A. Follow the procedures for submittals provided in Section 01300 – Submittals.
- B. Provide information on materials and construction of vaults, vault lids and frames, component construction, features, configuration, and dimensions.

1.6 Quality Assurance

- A. To ensure conformance to tensile strength requirements, the following procedure will be followed for each lot of castings used.
 - 1. All castings shall be Julian Heat dated.
 - 2. Two test bar specimens shall be poured when producing castings. Test bar specimens shall be Julian Heat dated. One test bar shall be sent to an independent laboratory for tensile strength testing. The other test bar shall be held at the foundry for a period of not less than one year.
 - 3. A test report from an independent laboratory verifying tensile strength shall accompany each shipment of castings. The heat date(s) on castings shall correspond to the tensile strength report(s).
- B. The manufacturer shall be a company specializing in manufacturing Products specified in this Section with minimum three years documented experience.
- C. Cold Weather Requirements: IMIAC - Recommended Practices and Guide Specifications for Cold Weather Masonry Construction.

1.7 Delivery, Storage and Handling

- A. Follow the provisions for the delivery, storage and handling of products to and at site provided in Section 01600 - Material and Equipment.

PART 2 PRODUCTS

2.1 Materials

- A. Concrete Vaults:
 - 1. Vault Sections: Reinforced precast concrete in accordance with ASTM C478 with gaskets in accordance with ASTM C923.
 - 2. Mortar: Proportions by volume shall be one part Portland cement, ASTM C150 Type I; two parts sand, ASTM C33; and 10 percent by volume of lime ASTM C207, Type S.
- B. Lids And Frames:

1. Castings shall conform to the requirements of ASTM Designation A48, Class 35B.
2. The word "WATER" shall be cast in the cover in 3" letters. The words Kansas City Missouri shall be cast in the cover in 1 ¼ " letters.
3. UNPAVED/EASEMENTS/GREENWAY Locations: Covers shall have "WATER" in the center.
 - a. The frame and cover shall be Deeter Foundry, Inc. #1320A or approved equal.
4. PAVED City/Public Street Right-of-way Locations: Castings installed in Paved areas will be adjustable/self leveling. Covers shall have "WATER" in the center.
 - a. 24" East Jordon Iron Works 3024 Self-Level Manhole Frame and Cover with 1040AGS "T" Gasket Cover or approved equal.

OR

b. 25" CertainTeed PAM VIATOP ductile iron casting reference #CDVT60QG or approved equal. ISO9000 certified foundry of all Ductile Iron components. Castings shall be third party certified 65-45-12 ductile iron and all related standards. Covers shall be hinged with drain and incorporate 90 degree blocking systems to prevent accidental closure. Casting shall have lifetime warranty for all components. Reference: AASHTO H20 and ISO 1083 or approved equal.

C. Vault Configuration

1. Shaft Construction: Concentric with lipped male/female joints; sleeve to receive pipe.
2. Shape: Cylindrical.
3. Clear Inside Dimensions:
 - a. 60" diameter
4. Clear Lid Opening: 26 inches diameter, minimum.
5. Pipe Entry: Provide openings as required.
6. Steps: See detail drawing No. 02608-1.

PART 3 EXECUTION

3.1 Examination

- A. Verify items provided by other sections of Work are properly sized and located.
- B. Verify that built-in items are in proper location, and ready for roughing into Work.
- C. Verify excavation for vaults is correct.
- D. Verify that subgrade will support vault.

3.2 Preparation

- A. Coordinate placement of inlet and outlet pipe or sleeves required by other sections.

3.3 Placing Vault Sections

- A. Place concrete blocks.
- B. Place vault sections plumb and level, at correct elevations.
- C. Set cover frames and covers level without tipping, to correct elevations.

3.4 Corrosion Protection

- A. Provide corrosion protection for the concrete and concrete reinforcement, when and as specified.
- B. Corrosion protection for concrete shall be required when the soil conditions indicate the need for sulfate resistant concrete and it is not available from the precast concrete member manufacturer.

END OF SECTION

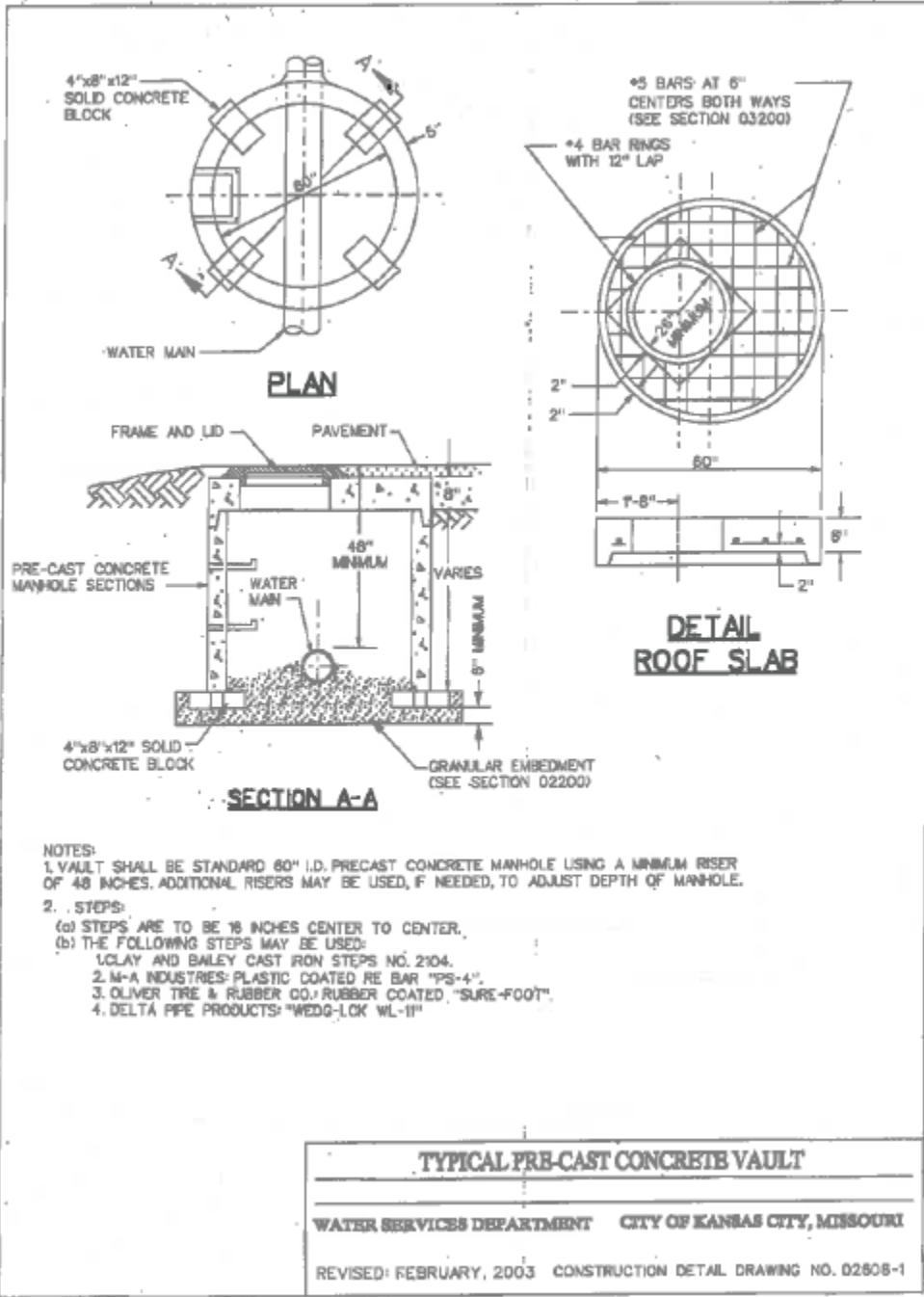

- NOTES:**
1. VAULT SHALL BE STANDARD 60" I.D. PRECAST CONCRETE MANHOLE USING A MINIMUM RISER OF 48 INCHES. ADDITIONAL RISERS MAY BE USED, IF NEEDED, TO ADJUST DEPTH OF MANHOLE.
 2. STEPS:
 - (a) STEPS ARE TO BE 18 INCHES CENTER TO CENTER.
 - (b) THE FOLLOWING STEPS MAY BE USED:
 1. CLAY AND BAILEY CAST IRON STEPS NO. 2304.
 2. M-A INDUSTRIES: PLASTIC COATED RE BAR "PS-4".
 3. OLIVER TIRE & RUBBER CO.: RUBBER COATED "SURE-FOOT".
 4. DELTA PIPE PRODUCTS: "WEDG-LOCK WL-11"

TYPICAL PRE-CAST CONCRETE VAULT

WATER SERVICES DEPARTMENT CITY OF KANSAS CITY, MISSOURI

REVISED: FEBRUARY, 2003 CONSTRUCTION DETAIL DRAWING NO. 02505-1

SECTION 02618

DUCTILE IRON PIPE WATER MAIN

PART 1 GENERAL

1.1 Section Description

- A. This section provides for pipe, fittings, and appurtenances associated with the installation of ductile iron pipe water main.

1.2 Section Includes

- A. Pipe
- B. Fittings
- C. Appurtenances
- D. Shop Coating and Lining
- E. Bolts and Nuts
- F. Protective Coatings

1.3 Related Sections

- A. Section 01016 – Water Mains Near Sewers
- B. Section 01300 – Submittals
- C. Section 01600 – Material and Equipment
- D. Section 02200 – Excavation and Trenching
- E. Section 02575 – Surface Restoration
- F. Section 02608 – Concrete Vaults
- G. Section 02641 – Valves
- H. Section 02645 – Hydrants, Blow-offs and Flushing Assemblies
- I. Section 02669 – Thrust Restraints
- J. Section 02675 – Water Main Testing, Disinfection and De-chlorination

1.4 References

- A. ANSI/NSF61 - Drinking Water Treatment Chemicals.

- B. ASTM A53 - Standard Specification for Pipe, Steel, Black and Hot-Dipped, Zinc Coated, Welded and Seamless.
- C. ASTM A307 - Standard Specification for Carbon Steel Bolts and Studs, 60,000 psi Tensile.
- D. ASTM D4976 - Standard Specification for Polyethylene Tubing.
- E. AWWA C104/ANSI A21.4 - Cement-Mortar Lining for Cast-Iron Pipe and Fittings.
- F. AWWA C105/ANSI A21.5 - Polyethylene Encasement For Ductile Iron Piping.
- G. AWWA C110/ANSI A21.10 - Gray-Iron and Ductile Iron Fittings.
- H. AWWA C111/ANSI A21.11 - Rubber-Gasket Joints for Cast Iron and Ductile Iron Pressure Pipe and Fittings.
- I. AWWA C115/ANSI A21.15 - Flanged Ductile-Iron Pipe with Ductile Iron or Gray Iron Thread.
- J. AWWA C150/ANSI A21.50 - Standard for the Thickness Design of Ductile Iron Pipe.
- K. AWWA C151/ANSI A21.51 - Ductile Iron Pipe Centrifugally Cast for Water.
- L. AWWA C153/ANSI A21.53 - Ductile-Iron Compact Fittings, 3 in. through 24 in.
- M. AWWA C203 - Standards for Steel Pipe.
- N. AWWA C550 - Protective Epoxy Interior Coatings for Valves and Hydrants.
- O. AWWA C600 - Installation of Ductile Iron Water Mains and their Appurtenances.

1.5 Submittals

- A. Follow the procedures for submittals provided in Section 01300 - Submittals
- B. Submit shop drawings and project data (laying schedule) for piping work showing pipe and fitting sizes, valve locations, joint details; and hydrant locations.

1.6 Quality Assurance

- A. Follow provisions of AWWA C600.
- B. The manufacturer shall be a company specializing in manufacturing the Products specified in this section with minimum three years documented experience.
- C. Mark rejected or defective materials and remove them from the work site.

1.7 Delivery, Storage, and Handling

- A. Follow the provisions for the delivery, storage, protection and handling products to and at site provided in Section 01600 - Material and Equipment.
- B. Accept piping on site. Inspect for damage and inventory.

PART 2 PRODUCTS

2.1 Water Main Pipe Materials

A. Pipe

- 1. Unless indicated otherwise, all 4" diameter through 12" diameter shall be thickness class 52. Pipe 16-inch diameter and larger shall be thickness Class 54 minimum. The pipe shall be designed in accordance with AWWA C150-ANSI A21.50 and manufactured per AWWA C151-ANSI A21.51 complete with all accessories.
- 2. All ductile iron pipe, and all fittings, valves, and other buried appurtenances, shall be encased in polyethylene.
- 3. Joints: The joints shall be of the push-on type unless otherwise specified conforming to ANSI/AWWA C111/A21.11, except gaskets shall be neoprene or synthetic rubber. Gaskets shall be certified as suitable for chlorinated potable water in accordance with ANSI/NSF61. Natural rubber will not be acceptable.
- 4. Restrained Joints: See Section 02669.

B. Fittings

- 1. All fittings shall be made of Ductile Iron and manufactured according to AWWA C110/ANSI A21.10 or AWWA C153/ANSI A21.53.
- 2. Fitting joints shall be Mechanical Joint (MJ), Flange Joint (FLG), or Push-On Joint, per AWWA C111/ANSI A21.11. All MJ glands shall be ductile iron. Fittings shall have distinctly cast upon them, the pressure rating and the letters "DI" or "Ductile". FLG Fittings shall be used only for aboveground installations.
- 3. Flanged Joints: Shall be provided with full-face gaskets and shall meet the requirements of AWWA C115/ANSI A21.15.

C. Appurtenances

- 1. Welded - On Outlets: May not be used in lieu of tees.
- 2. Tapping Sleeves:
 - a. Material: All material in the body, lugs, outlet, flange, bridge plate, bolts, nuts and washers shall be ASTM A-276 Type 304 or Type 316 or ASTM A-564 Type 630 stainless steel.

- b. Body: Shall be a minimum of 14 gauge stainless steel and shall fit cast iron pipe classes A, B, C, and D.
 - c. Outlet: Shall be a minimum of 14-gauge stainless steel. The branch outlet shall be supplied with a tap and plug to permit pressure testing the sleeve prior to tapping the main.
 - d. Flange: Shall conform to AWWA C207 Class D with drilling in accordance with ANSI B 16.1 class 125, and shall be indexed per MSS-SP 60 to accept tapping valve.
 - e. Welding: All welding on the coupling shall be done with stainless steel rods.
 - f. Gaskets: Sleeve gaskets shall be full circumferential a minimum of ¼" thick gridded with tapered lap joint ends and stainless steel bridge plates molded flush into the gasket.
 - g. The Outlet: The outlet flange face shall be supplied with a bonded, full-face gasket. All gaskets shall be grade 30 specially compounded rubber, synthetic rubber, or 100 percent neoprene that shall have the necessary qualities to allow outside storage, permanence, and resistance to set after installation.
 - h. Bolts and Nuts: All bolts, nuts and washers shall be loose; lifter bar style bolt attachments shall not be permitted. All bolts and/or nuts shall be impregnated or coated to prevent seizure. Minimum diameter shall be 5/8".
 - i. Working Pressure: Sleeve shall be designed for a minimum working pressure of 175 psi.
 - j. General: Power Seal Model 3490-AS; JMC 432; Cascade CST-Ex stainless steel extra heavy duty; Ford Model FTSS; Romac STD Band SST-III; Smith Blair Type 665.
 - k. Power Seal Model 3490MJ or approved equal may also be used.
3. Tie Rods: ASTM A276, Type 304 or Type 316 Stainless Steel.
4. Couplings: Dresser "Style 38" or Smith-Blair "441 or 411 Flexible Coupling"; without pipe stop. Bolted compression type couplings shall be manufactured of steel or ductile iron specifically for use with ductile iron pipe.

D. Shop Coating and Lining

- 1. All pipe and fittings shall be cement mortar lined in accordance with AWWA C104/ANSI A21.4. Pipe cement-mortar lining shall be without an asphaltic interior seal coating. All buried pipe and fittings shall be exterior coated with a black asphaltic coating minimum 1 mil in thickness per AWWA C151/ANSI A21.51. Any pipe or fittings above ground shall be prime coated with 6 mils DFT of Tnemec 140-1211 Epoxy Primer.
- 2. The exterior of ductile iron pipe shall be coated with a layer of arc-sprayed zinc per ISO 8179. The mass of the zinc applied shall be 200 g/m² of pipe surface area. A finishing layer topcoat shall be applied to the zinc. The mean dry film thickness of the finishing layer shall not be less than 3 mils with a local minimum not less than 2 mils. The coating system shall conform in

every respect to ISO 8179-1 "Ductile iron pipes - External zinc-based coating - Part 1: Metallic zinc with finishing layer. Second Edition 2004-06-01.

3. Ductile Iron Pipe used for sewers shall have an interior protective coating of Tnemec 431 coating.

E. Bolts and Nuts

1. Bolts: ASTM A307, chamfered or rounded ends projecting 1/4 to 1/2 inch from surface.
2. Nuts: ASTM A307, hexagonal, ANSI B18.2.2.

F. Marking:

1. Markings shall be legibly indented in the pipe or painted thereon with waterproof paint.

2.2 Protective Coatings

A. Polyethylene Encasement:

1. Polyethylene encasement materials shall be in accordance with ASTM D4976 and AWWA C105/ A21.5; LLD-12 mil or HDCL-4 mil. LLD-12 mil polywrap shall be blue.

<u>Item</u>	<u>LLD-12 mil</u>	<u>HDCL-4 mil</u>
Tensile Strength, psi	4,400	6,300
Elongation, percent	1,000	100
Dielectric Strength, v/mil	1,900	800
Tear Resistance, gf	4,400	250
Impact Resistance, g	1,100	800

2. The minimum tube size for each pipe diameter shall be in accordance with AWWA C105 as follows:

Polyethylene Flat Tube Width (inches)

Nominal Pipe Diameter (inches)	Push-on Bell & Spigot Joints	Mechanical Joints
4	14	16
6	17	20
8	21	24
10	25	27
12	29	30
14	33	34
16	37	37
18	41	41
20	45	45
24	53	53

3. Adhesive tape shall be a general purpose adhesive tape 1-inch wide and approximately 8 mils thick, such as Scotch Tape No. 50, Polyken No. 900, Tapecoat CT or approved equal (Duct Tape will not be allowed).
 - B. Exterior Surfaces Underground (Excluding Pipe & Fittings): All metal surfaces, including each mechanical coupling, shall be thoroughly cleaned and then coated with Tnemec coal-tar epoxy "High-Build Tnemec-Tar". All material and the application thereof shall conform to AWWA C203.
 - C. Above ground pipe and fittings shall be field coated with Tnemec Coal Tar Epoxy "High-Build Tnemec-Tar."

PART 3 EXECUTION

3.1 Handling

- A. Pipe, fittings, and accessories shall be handled in a manner that will ensure installation in a sound, undamaged condition. Equipment, tools, and methods used in unloading, reloading, hauling, and laying pipe and fittings shall be such that the pipe, pipe coating, and fittings are not damaged. Hooks shall not be used. Under no circumstances shall pipe or accessories be dropped or dumped. Pipe and fittings shall not be moved by inserting anything into pipe ends.
- B. Pipe and fittings on which the cement lining has been broken or loosened shall be replaced. Where the damaged areas are small and readily accessible, the lining may be permitted to be repaired in accordance with AWWA C104.

3.2 Inspection

- A. Pipe and fittings shall be carefully examined for cracks and other defects immediately before installation. Spigot ends shall be examined with particular care since they are vulnerable to damage from handling. All defective, damaged, or unsound pipe and fittings shall be rejected and marked as such and removed from the site of the work.

3.3 Preparation

A. Cutting Pipe:

1. Ductile iron pipe shall be cut with a saw or an abrasive wheel. Existing cast iron pipe shall be cut with a saw or abrasive wheel.
2. The cutting of pipe with a torch will not be permitted.
3. Cutting shall be done in a neat manner without damage to the pipe or the cement lining. Cuts shall be smooth, straight, and at right angles to the pipe axis. After cutting, the end of the pipe shall be dressed with a file to remove all roughness and sharp corners.

B. Cleaning:

1. The interior of all pipe and fittings shall be thoroughly cleaned of foreign matter before being installed and shall be kept clean until the work has been accepted.
2. Surfaces shall be wire brushed, if necessary, wiped clean, and kept clean until jointing is completed.

3.4 Installation

A. General

1. Alignment: Runs intended to be straight shall be laid straight. Deflections from a straight line or grade shall not exceed the quantities stipulated in Table 4 or Table 5 of AWWA C600. Shorter pipe sections or special bends shall be installed where the alignment or grade requires them.
2. Laying Pipe: Pipe shall be protected from lateral displacement by pipe embedment material installed as specified in Section 02200. Under no circumstances shall the pipe be laid in water; and no pipe shall be laid in unsuitable trench conditions.
 1. Pipe shall be laid with the bell ends facing the direction of laying except when reverse laying is specifically authorized by the WSD.
 2. Whenever pipe laying is stopped, the open end of the line shall be sealed with a watertight plug that will prevent water and objects from entering the pipe.
3. No pipe length less than 18" shall be used.

B. Mechanical Joints:

1. The gasket and gland shall, after proper joint cleaning, be in position on the spigot before shoving the pipe to its final position. Center the entering spigot so that the gland or follower ring is parallel to the face of the connecting bell. Joint shall be shoved "home" and the gland properly positioned with respect to the

connecting bell with the connecting pipes in as nearly perfect alignment as practicable. The bolts shall be slightly and uniformly tightened. Deflection may be made after the bolts are tightened.

2. Coat the gasket with a lubricant (suitable for potable water) supplied by the pipe manufacturer and all surfaces of the bell, spigot, and gland that will come in contact with the gasket at any time during assembly.
3. Gasket shall be carefully pushed into position and evenly seated in the bell. The gland shall be shoved into place against the gasket, the bolts inserted, and the nuts tightened with the fingers until snug. Final tightening of the bolts shall be done with a ratchet torque wrench.
4. Partially tighten the bottom bolt, then the top bolts, alternately either side, and finally the remaining bolts, alternately tightening bolts 180 degrees apart. This cycle is then to be repeated until all bolts are tightened to the torque specified by the manufacturer:

5/8" bolts --- 40 to 60 foot pounds

3/4" bolts --- 60 to 90 foot pounds

5. If sealing is not maintained at the torque specified, the joint shall be disassembled, thoroughly cleaned, and reassembled. Overstressing of bolts to compensate for poor installation practice will not be permitted.

C. Push-On Joints:

1. Wipe the gasket seat clean with a cloth and position in place. Coat the gasket with a lubricant supplied by the pipe manufacturer. Apply to all of the inner surface of the gasket that will come into contact with the entering pipe.
2. Clean the plain end of the pipe and apply a thin film of lubricant (suitable for potable water) to the outside of the plain end of the pipe and its beveled edge. Align the plain end of the pipe with the bell of the pipe to which it is to be joined. The joint deflection angle should not exceed the recommended maximum of the manufacturer.
3. Bring the plain end of the pipe in contact with the gasket and exert sufficient force on the entering pipe so that its plain end compresses the gasket and makes contact with the base of the socket of the bell. This force can be applied by means of a jack type tool, backhoe, or other methods approved by the WSD.

D. Flanged Joints:

1. When bolting, care shall be taken to provide uniform gasket compression and prevent unnecessary stress on the flanges. Flange shall be free to move in any direction while the flange bolts are being tightened. Bolts shall be tightened gradually and at a uniform rate to provide uniform gasket compression.
2. Use full-face gaskets only.

E. Restrained Joints:

1. Restrained joints shall be installed in accordance with the pipe manufacturer's recommendations.
2. All joints within utility casings shall be restrained joints.

F. Encasement:

1. Polyethylene encasement shall be installed on all ductile iron pipe and fittings. The polyethylene shall prevent contact between the pipe, fittings, and the surrounding embedment.
2. The polyethylene encasement shall be installed as specified in "Method A" below and as shown on the Construction Detail Drawing No. 02618-1.
 - a. Method A: Polyethylene tubing shall be approximately two (2) feet longer than the length of the pipe section to provide a one (1) foot overlap on each adjacent pipe section. Tube ends need not be taped in place unless directed by the WSD. Repair rips, punctures, or other damages to the polyethylene with adhesive tape or with a short length of polyethylene tube cut open, wrapped around the pipe, and secured with adhesive tape as directed by the WSD (duct tape is not allowed).
3. Pipe-Shaped Appurtenances: Bends, reducers, offsets, and other pipe-shaped appurtenances shall be covered with polyethylene in the same manner as the pipe.
4. Odd-Shaped Appurtenances: Valves, tees, crosses, and other odd-shaped pieces that cannot practically be wrapped in a tube shall be wrapped with a flat sheet or split length of polyethylene tube. The sheet shall be passed under the appurtenance and brought up around the body. Seams shall be made by bringing the edges together, folding over twice, and taping down. Tape polyethylene securely in place at overlaps, valve tops and all other penetrations.
5. Lifting devices shall not be placed over polyethylene.
6. Polyethylene shall be protected from exposure to weather or damage at all times.
7. Openings in Encasement: Openings for branches, service taps, blow-offs, air valves, and similar appurtenances shall be made by making an x-shaped cut in the polyethylene and temporarily folding the film back. After the appurtenance is installed, tape the slack securely to the appurtenance and repair the cut as well as any other damaged areas in the polyethylene with tape. The new appurtenance shall be wrapped.
8. Junctions between Wrapped and Unwrapped Pipe: Where polyethylene wrapped pipe joins an existing pipe which is not wrapped, extend the

polyethylene tube to cover the unwrapped pipe a distance of at least three feet. Secure the end with circumferential turns of tape.

9. Taps: Wrap 3 layers of adhesive tape over the polyethylene, covering the area where the tapping machine will be mounted. Mount the machine over the tape. Make the tap and install the corporation stop through the tape and polyethylene. After making the service connection, inspect the polyethylene, and repair damaged areas with tape.

3.5 Water Main and Sewer Separation

- A. Refer to Section 01016

3.6 Appurtenances

- A. Concrete Vaults: Refer to Section 02608
- B. Valves: Refer to Section 02641
- C. Hydrants, Blow-off, and Flushing Assemblies: Refer to Section 02645
- D. Thrust Restraints: Refer to Section 02669

END OF SECTION

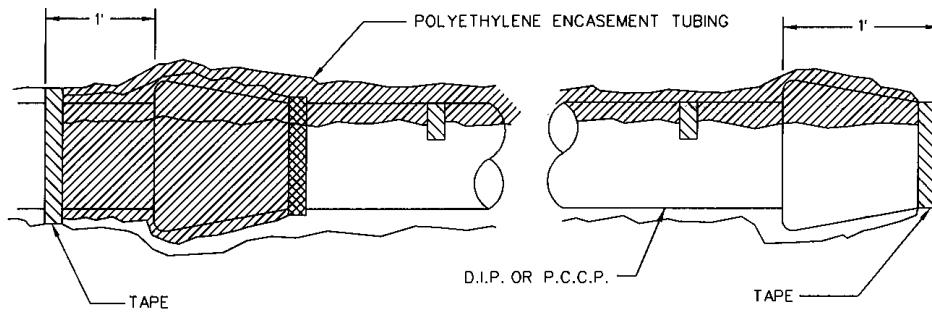

METHOD A

NOTES

1. TAPE IN ACCORDANCE WITH AWWA C-105

POLYETHYLENE ENCASEMENT FOR BURIED PIPE

WATER SERVICES DEPARTMENT CITY OF KANSAS CITY, MISSOURI

REVISED: APRIL 2014

CONSTRUCTION DETAIL DRAWING NO. 02618-1

SECTION 02641

VALVES

PART 1 GENERAL

1.1 Section Description

- A. This section provides for the installation of required valves for water main construction.

1.2 Section Includes

- A. Gate Valves
- B. Butterfly Valves
- C. Air Release Valves
- D. Tapping Valves
- E. Valve Boxes, Bases, Lids and Covers, Torque Limiting Devices
- F. Valve Seals and Coatings
- G. Check Valves

1.3 Related Sections

- A. Section 01300 – Submittals
- B. Section 01600 – Material and Equipment
- C. Section 02608 – Concrete Vaults
- D. Section 02618 – Ductile Iron Pipe Water Main
- E. Section 02669 – Thrust Restraints

1.4 References

- A. ANSI B16.1 - Pipe Flanges and Flanged Fittings, Cast-Iron
- B. ANSI/AWWA C110/A21.10 - Ductile-Iron and Gray-Iron Fittings.
- C. ANSI/AWWA C111/A21.11 - Rubber-Gasket Joints for Ductile-Iron Pressure Pipe and Fittings.
- D. AWWA C504 - Rubber-Seated Butterfly Valves.

- E. AWWA C509-94 - Standard Specification for Resilient Seated Gate Valves for Water Supply Service.
- F. AWWA C512-99 - Air Release, Air/Vacuum, and Combination Air Valves for Water Works Service.
- G. ASTM A48 - Standard Specifications for Gray-Iron Castings.
- H. ASTM A126 - Standard Specifications for Gray-Iron Castings for Valves, Flanges, and Pipe Fittings.
- I. ASTM A276 - Standard Specification for Stainless Steel Bars and Shapes.
- J. ASTM A536 - Standard Specification for Ductile Iron Castings.
- K. ASTM A564 - Standard Specification for Hot-Rolled and Cold-Finished Stainless Steel Bars and Shapes.
- L. ASTM D471 - Standard Test Method for Rubber Property-Effect of Liquids.
- M. ASTM D1149 - Standard Test Method for Rubber Deterioration-Surface Ozone Cracking in a Chamber.
- N. C508: Swing-Check Valves for Waterworks Service, 2 in. through 24 in.

1.5 Submittals

- A. Follow the procedures for submittals provided in Section 01300 - Submittals
- B. Shop Drawings: Detailed drawings, data and descriptive literature on all valves and appurtenances, including:
 - 1. Manufacturer
 - 2. Dimensions
 - 3. Size
 - 4. Materials of construction
 - 5. Weight
 - 6. Protective coating
 - 7. Actuator weight and turns to operate where applicable
 - 8. Calculations for actuator torque where applicable
 - 9. Proof of design tests in accordance with Sec. 5.2.4. AWWA C504
 - 10. Cross section drawings detailing all components

- C. The Contractor shall submit descriptive literature describing the proposed valves and accessories. Contractor shall also furnish a copy of the manufacturer's warranty that applies to the valves and actuators.

1.6 Quality Assurance

- A. Valves shall be manufactured by a company specializing in the regular production of the Products specified herein and proven reliable in similar service for at least five (5) years.
- B. Insofar as possible, all valves of the same specific type shall be the product of one (1) manufacturer.

1.7 Delivery, Storage and Handling

- A. Follow the provisions for the delivery, storage, protection and handling Products to and at site provided in Section 01600 - Material and Equipment.

PART 2 PRODUCTS

2.1 General

- A. Marking and identification of valves shall conform to AWWA C504 or AWWA C509.

2.2 Gate Valves

- A. Gate Valves: Except as modified or provided herein, all gate valves shall be 200 psi, ductile iron body, resilient-seated, tight closure gate valves with non-rising stems conforming to the requirements of AWWA C509. Thin wall valves are prohibited.
- B. Valve Ends:
 - 1. Mechanical Joint or Push On Joint: Conforming to ANSI/AWWA C111/A21.11 except where flange ends are required. All glands shall be ductile iron.
 - 2. Flanged: Conforming to the dimensions and drilling of ANSI B16.1 for cast iron flanges and flange fittings, Class 125. The laying lengths of the flange valves shall conform to the dimensions of ANSI B16.1.
- C. Valve Gate: Wedge type gate with a minimum 3/8 inch thick resilient rubber, urethane rubber, Buna "N" or SBR rubber bonded to or mechanically attached to one side or both sides of the gate. No sliding or shear is permitted on the resilient seat, when compressed to a drop-tight shut-off.
- D. Fasteners: All exterior bolts and nuts shall be ASTM A276 Type 304 or Type 316 stainless steel.

- E. Operating Nut: The valve shall be equipped with a two-inch square AWWA **stainless steel** nut having a flanged base upon which shall be cast the word OPEN and an arrow indicating the direction to open. The nut shall be securely pinned to the actuator shaft using a stainless steel fastener
- F. Valve Stems: The gate valve stems shall be produced from a material that is corrosion resistant to potable water and has a minimum yield strength of 40 KSI.
- G. Seals: Gate Valves shall be provided with stem seals of the "O" ring type. Two "O" rings shall be used with at least one "O" ring inserted above the thrust collar. The packing plate shall be attached to the valve bonnet by not less than two (2) bolts if bolts are required and one "O" ring below the thrust collar.
- H. Coatings: All exterior surfaces of each valve shall be cleaned and painted in the shop with two (2) coats of asphalt varnish conforming to Federal Specifications TT-V-51-E. The interior surface shall have a protective coating of fusion-bonded, non-toxic epoxy that is safe for potable water. Non-toxic epoxy may also be used for exterior coating
- I. Tapping Valves: The valves shall be 200 psi, ductile iron body, resilient-seated, tight closure gate valves with non-rising stems in conformance with ANSI/AWWA C509, except that the outlet end shall be a standard mechanical joint end conforming to ANSI/AWWA C111/A21.11 and the inlet end shall have an inlet flange conforming to ANSI B16.1 for cast iron flanges, Class 125. Gland shall be ductile iron. Approved mechanical joint valves shall be used with Power Seal Model 3490MJ tapping sleeves.

2.3 Butterfly Valves

- A. General: These specifications provide for the purchase and installation of ductile iron, vault installation or direct bury, rubber-seated, tight closure in both directions, 16 fps butterfly valves and actuators in sizes from 16-inch through 90-inch diameter. All valves shall be Short-Body Flanged-end valves for use in vaults or Mechanical-Joint-end valves for direct bury. The valves and actuators shall be of the latest model with all standard accessories ordinarily furnished to the industry except as otherwise specified herein. All valves of one size shall be built by one manufacturer with actuators built by one manufacturer. The latest revision of AWWA C504, Standard for Rubber Seated Butterfly Valves, shall govern unless noted otherwise herein. The intent of all provisions of AWWA C504 shall apply equally to valves larger than 48" diameter and to 250 psi valves unless noted otherwise herein. Each valve shall have a unique serial number, which shall be part of the information on the tag specified in paragraph 10.
- B. Owner's Data: The quantity, pressure rating, valve material type, and sizes shall be as indicated on the drawings. Each valve shall be fastened to and delivered on an individual pallet on 4" x 4", or heavier, wood skids, high enough to protect the valve and actuator. All other requirements of AWWA C504 Section 6.2 "Shipping" shall apply. Delivery shall be to the jobsite.
- C. Descriptive Literature: The Bidder shall include literature describing the valves and actuators to be furnished.

- D. Warranty: The Supplier shall furnish three copies of the warranty that applies to the valves and actuators they propose to furnish. The warranty period shall be for a minimum of three years after substantial completion of the contract under which the valve is installed or twenty years from the date of shipment, whichever comes first.
- E. Shop Drawings: The approved Supplier, ONLY, before manufacturing the valves and actuators, shall submit eight (3) sets of certified shop drawings, parts lists, exploded assembly drawings, and material specifications, for approval, to the WSD. In addition to the above, the supplier shall furnish certified copies of proof-of-design tests performed in accordance with Section 5.2.4 of AWWA C504.
- F. Design: All valve parts shall be designed for a minimum safety factor of 3, based on yield strength, or 5, based on tensile strength.
- G. Flow Coefficient "K": The flow coefficient in terms of velocity head (K), in the full open position, shall not be greater than the following:

	<u>75 psi</u>	<u>150 psi</u>	<u>250 psi</u>
16 inch thru 24 inch	K=0.40	K=0.45	K=0.55
30 inch thru 48 inch	K=0.40	K=0.40	K=0.50
54 inch thru 72 inch	K=0.40	K=0.40	-----
78 inch thru 90 inch	K=0.40	-----	-----

Pressure measurements shall be made at two pipe diameters upstream of the valve and eight pipe diameters downstream of the valve in accordance with recommended procedures of ASME Report on Fluid Meters, Latest Edition.

- H. Minimum Port Diameter: The minimum port diameter through the valve shall not be less than as listed below:

<u>Nominal Size</u>	<u>Allowable Difference in Diameter</u>
16-inch - 42 inch	1 inch
48-inch - 54-inch	1 1/4-inch
60-inch - 72-inch	1 1/2-inch
78-inch - 90-inch	3 inch

- I. Fasteners: All bolts and nuts inside and outside the valve, except Mechanical Joint bolts and nuts, shall be ASTM A276 Type 304 or Type 316 stainless steel or ASTM A564 Grade 630 stainless steel.
- J. Valve Body: The valve body shall be ductile iron poured to full gray iron thickness.

The position of the valve seat in the valve body shall be marked on the outside of the valve body, within 12 inches of the actuator nut of upper valve trunion, tagged or cast, in 1/4" high print, "SEAT THIS SIDE." Tags shall be ASTM A276 Type 304 or Type 316 stainless steel.

- K. End Plate: No bolt or end thrust adjusting screw shall extend through the End Plate.
- L. End Connections: The dimensions and drillings of end flanges shall conform to ANSI B16.1 for 75 psi valves, ANSI B16.1 Table 5 for 150 psi valve and 250 psi valves, both with 150 psi drillings. If specified in the invitation to bid, 250 psi dimensions and drillings of end flanges shall conform to ANSI B16.1 Table 8, to include but not be limited to, flange outside diameter, flange thickness, bolt circle diameter, bolt diameter, and bolt quantity. The Mechanical Joint valves are to include the following accessories: gaskets, ductile iron gland rings, mechanical joint bolts, and nuts.
- M. Shafts: All valve shafts shall be in accordance with AWWA C504 Table 3 unless otherwise addended herein. All valve shafts, dowels, and taper pins shall be ASTM A276 Type 304 or Type 316 stainless steel or ASTM A564 Grade 630 condition H1100 stainless steel. The valve shaft shall have a means of clearly indicating the position of the disc on the actuator end of the shaft. This mark shall be machine grooved and shall be visible when the cover and lubrication are removed and shall be offset to the same side as the disc. The valve shaft shall be completely enclosed between the valve body and the actuator body.
- N. Valve Disc: The valve disc shall be ductile iron and shall seat perpendicular to the centerline axis of the valve body.
- O. Valve Seats: The resilient seat shall be EPDM synthetic rubber applied either to the valve disc or valve body. The resilient seat shall be mechanically secured to either the valve disc or valve body with ASTM A276 Type 304 or Type 316 stainless steel fasteners or non-bonding epoxy. Resilient seats shall be field adjustable and replaceable without special tools or instruction.

Mating surfaces for the valve seats shall be ASTM A276 Type 304 or Type 316 stainless steel.

All seats shall be designed to provide tight shut-off with flow in both directions.

- P. Shaft Seals: Seal shall be provided by the use of standard V-type packing or standard "O" ring seals; pull-down packing is not acceptable. The valve shall be designed so that the actuator may be removed and replaced while the valve is in service without losing water.
- Q. Actuator: The actuator shall be Limitorque Model HBC series or Auma Model GS series (additional spur gear reduction gear boxes may be necessary to achieve minimum "number of turns" requirement) or those that have received written approval after May 1, 2002 from the Water Services Department. The actuator shall be a link lever traveling nut type, worm gear type, or yoke and nut type and shall be capable of withstanding submersion in water to a pressure of 10 psi. All exposed bolts, nuts, and shafts shall be of ASTM A276 Type 304 or Type 316 stainless steel or ASTM A564 Grade 630 condition 1100 stainless steel. All actuators must have outside mechanical adjustments capable of adjusting valve travel without removing the valve from the pipeline or removing the actuator cover.

Buried service valves shall open right (clockwise). The actuator shall be equipped with a two-inch square AWWA ductile iron nut having a flanged base upon which

shall be cast the word OPEN and an arrow indicating the direction to open. The nut shall be securely pinned to the actuator shaft using a stainless steel fastener.

Vault service valves shall open left (counter-clockwise). The actuator shall be supplied with a handwheel. The handwheel shall be no smaller in diameter than 30 inches and no larger in diameter than 36 inches. Manual actuators shall be suitable for future adaptation to motor operation. Vault service actuators shall have an indicator on the exterior of the actuator indicating the valve disc position. This indicator shall be stainless steel.

All gearing and actuator stops shall be enclosed in a suitable housing with a removable cover to permit inspection, repair, and adjustment of the mechanism. Adjustable stop limiting devices shall be provided inside the actuator housing to stop the input shaft at full open and full closed positions. The use of stop nuts or shaft collars which rely on clamping forces or set screws to prevent rotation of the nut or collar on the screw shaft will not be acceptable.

The actuator shall rotate the disc from full open to full closed and vice-versa using not less than, nor more than, the number of turns indicated below:

Valve Size (Inches)	Minimum Turns	Maximum Turns
16	30	60
20	40	80
24	40	80
30	40	200
36	80	200
42	80	220
48	90	300
54	90	700
60	200	700
72	200	700
90	200	700

The number of turns shall be included in the information on the tag specified in paragraph 10.

- R. Painting Interior of Valves: The interior of valves sizes 16-inch through 48-inch shall be coated with a white, NSF 61 certified, fusion-bonded or powder coated epoxy. The interior of valve sizes 54-inch through 90-inch shall be coated with a white epoxy paint, Tnemec N141 NSF 61 or approved equal. Surface preparation and application shall be in accordance with SSPC PA-1. The dry film thickness of the coating shall be a minimum of 10 mils. A painting Affidavit of Compliance shall be submitted in accordance with paragraph 21 and AWWA C550 NSF 61 and shall be free of holidays.

- S. Painting Exterior of Valves: The exterior of valve sizes 16-inch through 48-inch shall be coated with an NSF 61 certified, fusion-bonded or powder coated epoxy. The exterior of valve sizes 54-inch through 90-inch shall be coated with an epoxy paint, Tnemec N141 NSF 61 or approved equal. Surface preparation and application shall be in accordance with SSPC PA-1. The dry film thickness of the coating shall be a minimum of 10 mils. A painting Affidavit of Compliance shall be submitted in accordance with paragraph 21 and AWWA C550 NSF 61 and shall be free of holidays.
- T. Factory Inspection: The Water Services Department's inspector will witness leakage and hydrostatic tests at the Manufacturer's facility and will inspect all valves for conformance to the specifications. The Manufacturer shall include in the bid all expenses for transportation, lodging, and meals required by the Department's inspector to complete the inspection. Absolutely no expenses are to be paid by the inspector at any time.

After the valves are delivered, the Water Services Department may again test the valves and actuators for compliance with the specifications. The valves that do not meet specification will be shipped back to the manufacturer for modifications, at the Manufacturer's expense. The manufacturer shall also be responsible for all testing expenses incurred by the Department if the valve fails to perform as specified herein.

- U. Tests: All test data per AWWA C504 shall be submitted in triplicate to the WSD.
- V. Affidavit of Compliance: The manufacturer shall send an affidavit of compliance, in triplicate, to the WSD.
- W. Torque Limiting Devices: Contractor shall provide a Torque Limiting Device for each direct-bury butterfly valve as specified herein.
1. The torque limiting device shall make over-torque, in either direction, impossible. The unit shall be preset and designed to release when the torque level exceeds 210 foot pounds on the operating nut, in either direction, OPENING or CLOSING the valve. The torque unit shall reset automatically when the torque level drops below 200 foot pounds on the operating nut in either direction.
 2. The torque level of the unit shall be adjustable so it may be field set to release at a desired torque limit.
 3. The device shall be model D86 Overtorque Protector, manufactured by Aunspach Controls Co, Inc. or approved equal.
 4. The unit shall be less than 5-1/4 inches in diameter and made to mount on the valve inside of the 6-inch diameter stem riser tube of the valve box or in the valve box.
 5. The unit shall be provided with a two-inch AWWA operating nut, securely attached to the device. The nut shall have an arrow on the base indicating the valve opens to the "RIGHT" (clockwise) and the word "OPEN". The unit shall be provided with a two-inch square tapered AWWA socket securely attached to the device. The socket shall fit a 2-inch AWWA nut.

6. The unit shall be designed to withstand submersion in water to a pressure of 10 psi; to endure long periods (years) of active or inactive use buried underground and submerged in water. The unit shall be sealed to prevent water and direct from entering the mechanism. The unit shall be packed with a suitable grease.
7. All housing parts, including nut and socket, shall be coated inside and outside with catalyzed (2-part) epoxy. A top coat of catalyzed (2-part) polyurethane enamel shall be applied over the epoxy for additional hardness and extra corrosion protection.
8. Contractor shall mount the torque limiting device's integral socket on each butterfly valve's 2-inch AWWA operating nut inside of the stem riser tube before backfilling around the valve. No fasteners or screws shall be used.

2.4 Air Release Valves

A. Air Release Valves and Vaults:

1. Air release assemblies shall be manufactured in accordance with AWWA C512.
2. Air release valve vaults and castings: Refer to Section 02608.
3. All piping shall be brass pipe except the air outlet from the air release valve that shall be brass or copper tubing. Brass piping shall be ASTM B43, Extra Strong with ASME 816.1 Class 250 fittings.

B. Air Release Valves for mains 12-inches in diameter or smaller (3/4-inch Diameter):

1. Isolation valves shall be 3/4-inch bronze ball valves, 150 psi working pressure.
2. The 3/4-inch air release assembly shall be as manufactured by ARI Flow Control Accessories, Model S-050 or an approved equal.
3. Air release valves shall be installed in accordance with Drawing No. 02641-1.
4. Provide vault cover with minimum one 1-inch dia. hole for air flow.

C. Air Releases Valves for mains larger than 12-inches in diameter as specified on the Contract Drawings:

1. For 2-inch air release valves:
 - a. Each assembly shall have a two-inch inlet connection.
 - b. Isolation valves shall be 2 inch bronze ball valves with screwed, non-rising stems, 175 psi working pressure..
 - c. The 2-inch air release valve shall be an ARI Flow Control Accessories Combination Air Release Valve, Model D-040 or approved equal.

- d. The 2-inch air release valves shall be installed in accordance with Drawing No. 02641-2.
 - e. Provide vault cover with a minimum four 1-inch dia. holes for air flow.
2. For 3-inch air release valves:
- a. The 3-inch air release valve shall be an ARI Flow Control Accessories Combination Air Release Valve, Model D-060-C HF or approved equal.
 - b. The 3-inch air release valves shall be installed in accordance with Drawing No. 02641-2B
 - c. Provide vault cover with a minimum nine 1-inch dia. holes for air flow.

2.5 Valve Boxes, Bases, Lids and Covers

- A. One-piece Valve Boxes and Bases:
- 1. One-piece valve boxes and bases shall be injection molded plastic conforming to ANSI/ASTM 2853, Class 1212 as manufactured by Ametek or approved equal.
- B. Two-piece Valve Box and Base:
- 1. Valve Boxes: Boxes shall be 6" Class 52 DIP; or 6" Class 160 PVC pipe. Bases are required on all valves.
 - 2. Valves Bases: Valve bases shall be Clay & Bailey No. 2260-4 or an approved equal.
- C. Lids and Covers: Valve lids and covers shall be Clay & Bailey No. 2193, 2193NS or an approved equal. Valve lids shall have "Water" cast in the lid.

2.6 Check Valves

- A. All check valves shall be Ken-Flex Resilient Hinge check valves as manufactured by Kennedy Valve Company or approved equal.
- B. Check valves shall be ductile iron body with reinforced Buna-N rubber flapper.
- C. Check Valves shall be rated for 250 psi working pressure, 500 psi hydrostatic test for structural soundness.
- D. Check Valves shall have ANSI 16.1 – Class 125 flanged end connections.
- E. The check valve body shall have full flow equal to nominal pipe diameter at all points in the valve. The valve body shall be of ductile iron construction to ASTM-A-536 –

65-45-12. Castings will be clean and sound without defects that will impair their service. No plugging or welding of such defects will be allowed. The seating surface will be at a 45 degree angle to minimize water hammer.

- F. Rubber Clapper & Hinge shall be constructed of ductile iron to ASTM-A 536-65-45-12. Both Clapper and hinge shall have permanently bonded Buna-N rubber with a metal reinforcement connecting the hinge to the clapper.
- G. The top cover plate will be of ductile iron to ASTM-A536-65-45-12 & must be of full size to allow removal of the disc without removing the valve from line. All exterior nuts and bolts shall be 304 or 316 stainless steel.
- H. All iron parts inside and out will be fusion bonded epoxy coated. All coatings must be NFS-61 approved for use in drinking water systems.
- I. Vault service check valves shall have an external mechanical position indicator.

PART 3 EXECUTION

3.1 Inspection

- A. Each valve shall be inspected before installation to insure that all foreign substances have been removed from within the valve body, and shall be opened and closed to see that all parts are in required working condition.

3.2 Setting Valves

- A. All valves and fittings shall be set and jointed in the manner specified herein. The valves shall be set vertical in the horizontal pipeline. All valves shall be anchored directly to adjacent tees or crosses.
- B. One-piece valve box and base or a two-piece valve box and valve base shall be installed on all valves. An approved valve box alignment device shall also be installed in all valve boxes.
- C. Valve covers, bases, and lids shall be supported and maintained, centered and plumb over the actuator nut. Cover shall be flush with the roadway or ground surface or at such other as directed by the WSD.

3.3 Appurtenances

- A. Hydrants; Blow-off, and Flushing Assemblies: Refer to Section 02645
- B. Concrete Vaults and Covers: Refer to Section 02608
- C. Thrust Restraints: Refer to Section 02669
- D. General
 - 1. Certification: The manufacturer shall provide an affidavit in triplicate certifying that the valves and actuators comply with the provisions of these Specifications.

E. Leak Tests: (for Butterfly Valves)

1. Each valve shall be shop tested in both directions for leaks in the closed position. The test shall be conducted with the body in a horizontal plane.
2. Air pressure shall be applied to the lower face of the disc for 5 minutes.
3. Both 150-psi and 250-psi rated valves shall be leak tested to 250-psi pressure.
4. The upper surface of the valve disc shall be visible and covered with a pool of water at "O" psi pressure. There shall be no leakage past the valve disc. Bubbles will appear in the water on the disc if it is leaking.
5. The valve body shall be tested with an internal hydrostatic pressure equivalent to two times the specified shutoff pressure. There shall be no leakage, during the test, through the metal, the end joints, or the shaft seals; nor shall any part be permanently deformed.
6. The hydrostatic test period for 4-inch valve bodies through 20-inch bodies shall be at least 3 minutes. Valve bodies 24-inch and larger shall be tested for at least 10 minutes.

F. Performance Tests:

1. Each valve shall be shop operated three times from full closed to full open position, and reverse, under no flow condition to demonstrate that the complete assembly is workable.
2. Each valve should also be tested in the same manner following installation.

END OF SECTION

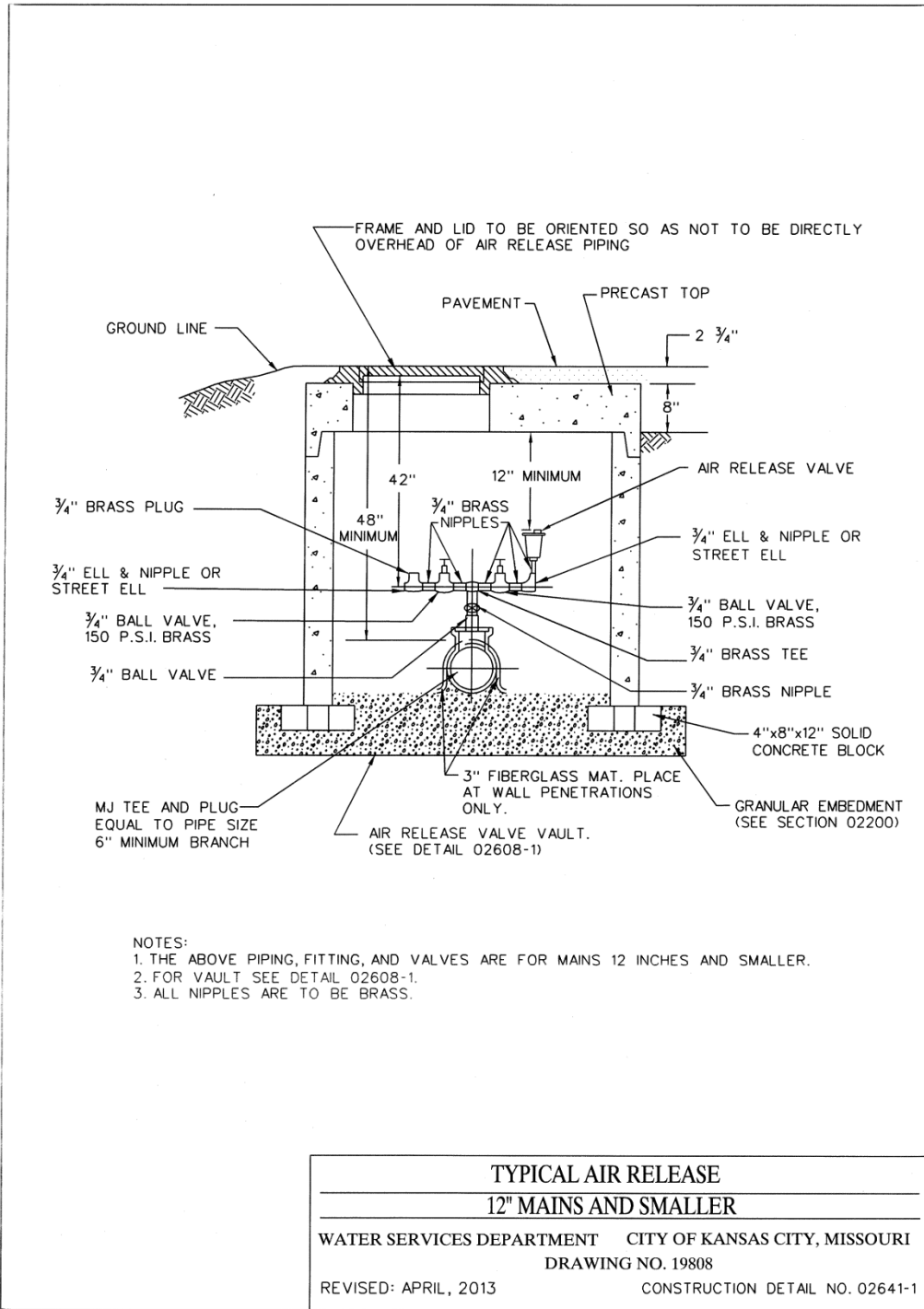

WaterWMSStd-airrelease.dgn 5/7/2013 4:25:07 PM

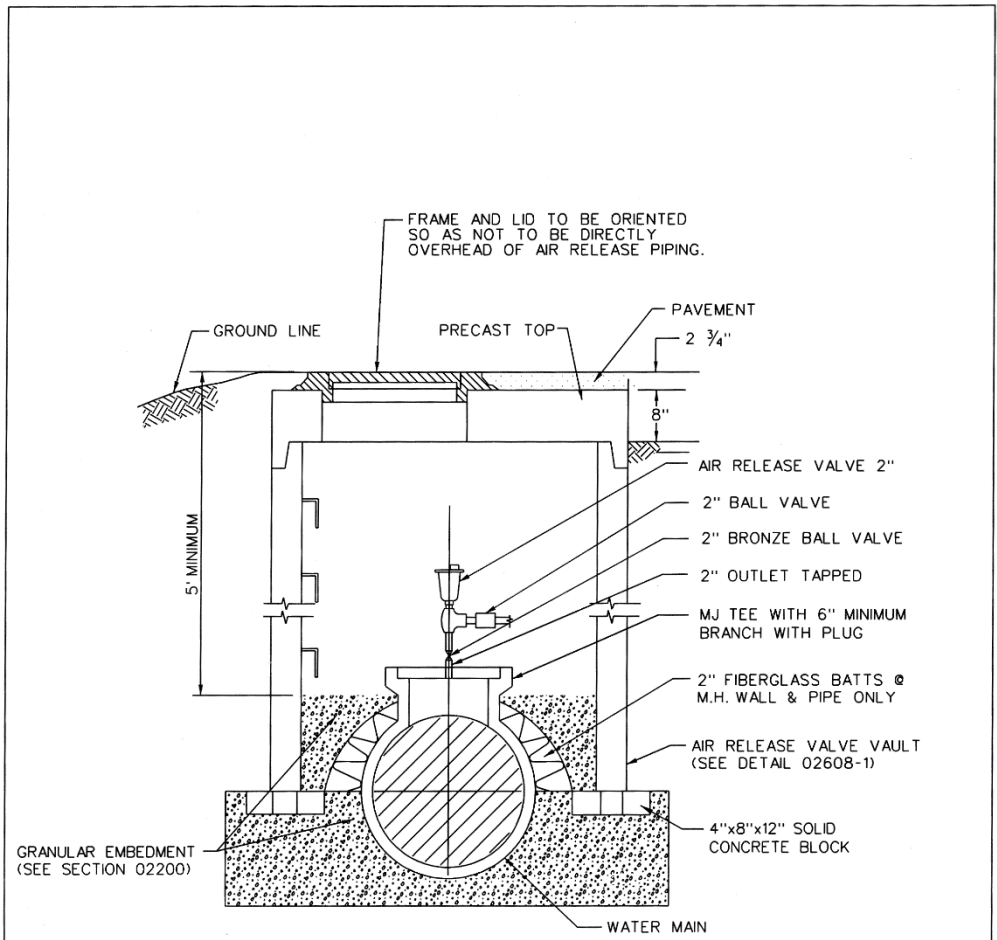

NOTES:

1. THE ABOVE PIPING, FITTINGS AND VALVES ARE FOR MAINS 16 INCHES AND LARGER.
2. FOR VAULT SEE DETAIL 02608-1.
3. ALL NIPPLES ARE TO BE BRASS.

TYPICAL AIR RELEASE 2" OR SMALLER	
16" MAINS AND LARGER	
WATER SERVICES DEPARTMENT CITY OF KANSAS CITY, MISSOURI	
REVISED: APRIL, 2013	CONSTRUCTION DETAIL DRAWING NO. 02641-2

...Air_Release_det43013.dgn 5/7/2013 4:27:34 PM

DEETER FOUNDRY PRODUCT NO.1194
 MANHOLE RING & SOLID COVER
 WITH "WATER KCMO" LETTERS
 AND FOUNTAIN LEGEND.
 PROVIDE COVER WITH NINE
 1-INCH DIA. HOLES FOR AIR FLOW.

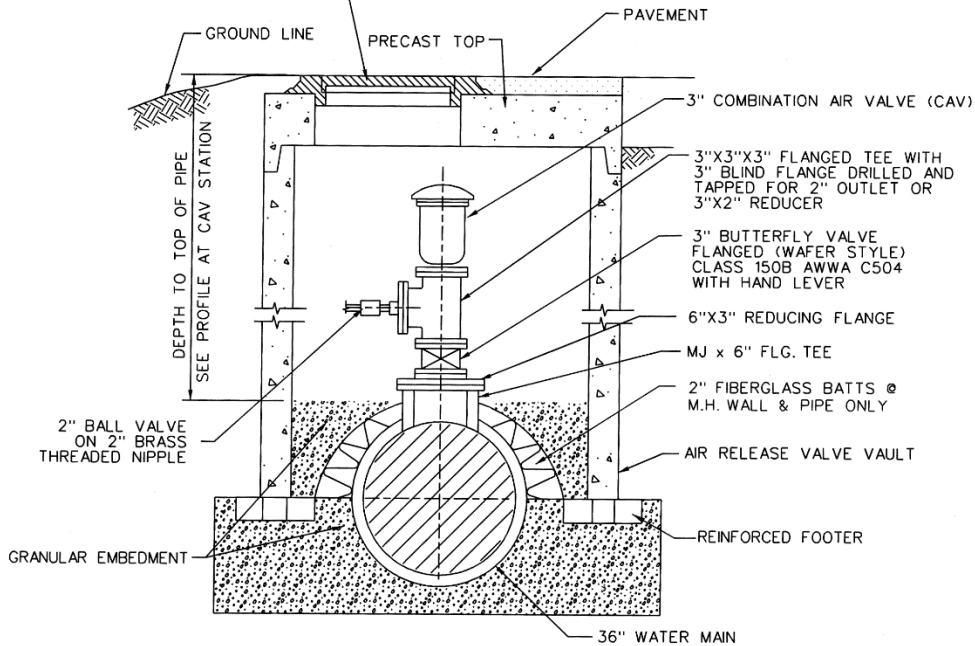

NOTES:

1. FOR VAULT DETAILS, SEE SECTION 02608, KCMO WSD STANDARDS AND SPECIFICATIONS AND ASTM C478. TOP, RISER, & FOOTERS, SHALL BE SUITABLE FOR TRAFFIC CONDITIONS AND DESIGNED TO MEET H-20 WHEEL LOAD REQUIREMENTS.
2. BRASS PIPING SHALL BE ASTM B43, EXTRA STRONG W/ ASME 816.1 CLASS 250 FITTINGS
3. CAV TO BE A.R.I. FLOW CONTROL CAV MODEL NO. D-060-C HF OR APPROVED EQUAL.
4. WHERE VAULT IS INSTALLED OUTSIDE OF PAVEMENT LIMITS, PROVIDE MINIMUM 12" OF SOIL ABOVE VAULT TOP FOR RESTORATION OF GRASS OR LANDSCAPE FEATURES AND GRADE TO MATCH ADJACENT EXISTING SURFACE.

TYPICAL AIR RELEASE 3" OR LARGER
 16" MAINS AND LARGER

WATER SERVICES DEPARTMENT CITY OF KANSAS CITY, MISSOURI

REVISED: APRIL 2013 CONSTRUCTION DETAIL DRAWING NO. 02641-2B

...13-INCH CAV DETAIL Rev42913 dgn 5/7/2013 4:09:27 PM

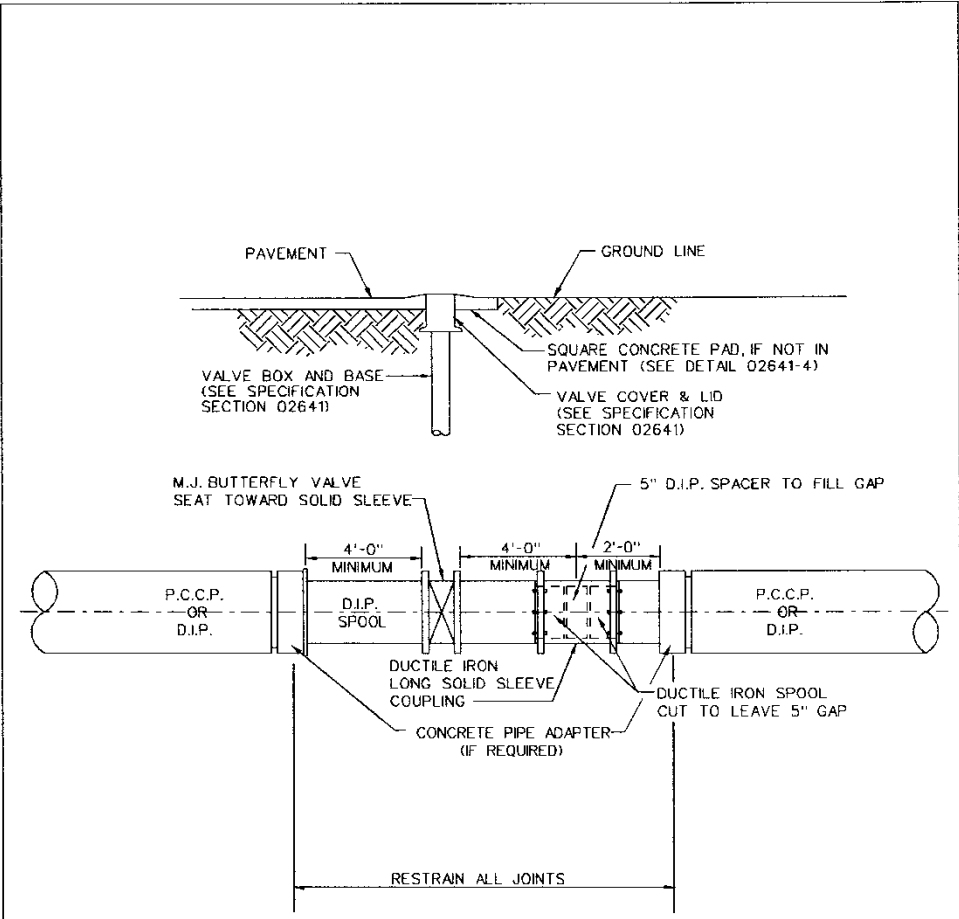

- NOTES:
1. TORQUE LIMITERS TO BE PLACED ON ALL BUTTERFLY VALVES.
 2. ALL PIPE AND BOLTS TO BE PAINTED WITH ONE COAT COAL TAR EPOXY AFTER ASSEMBLY.
 3. RESTRAIN ALL JOINTS BETWEEN ADAPTERS.

TYPICAL BUTTERFLY VALVE INSTALLATION	
WATER SERVICES DEPARTMENT	CITY OF KANSAS CITY, MISSOURI
	DRAWING NO. 19808
REVISED: MARCH, 2011	CONSTRUCTION DETAIL NO. 02641-3

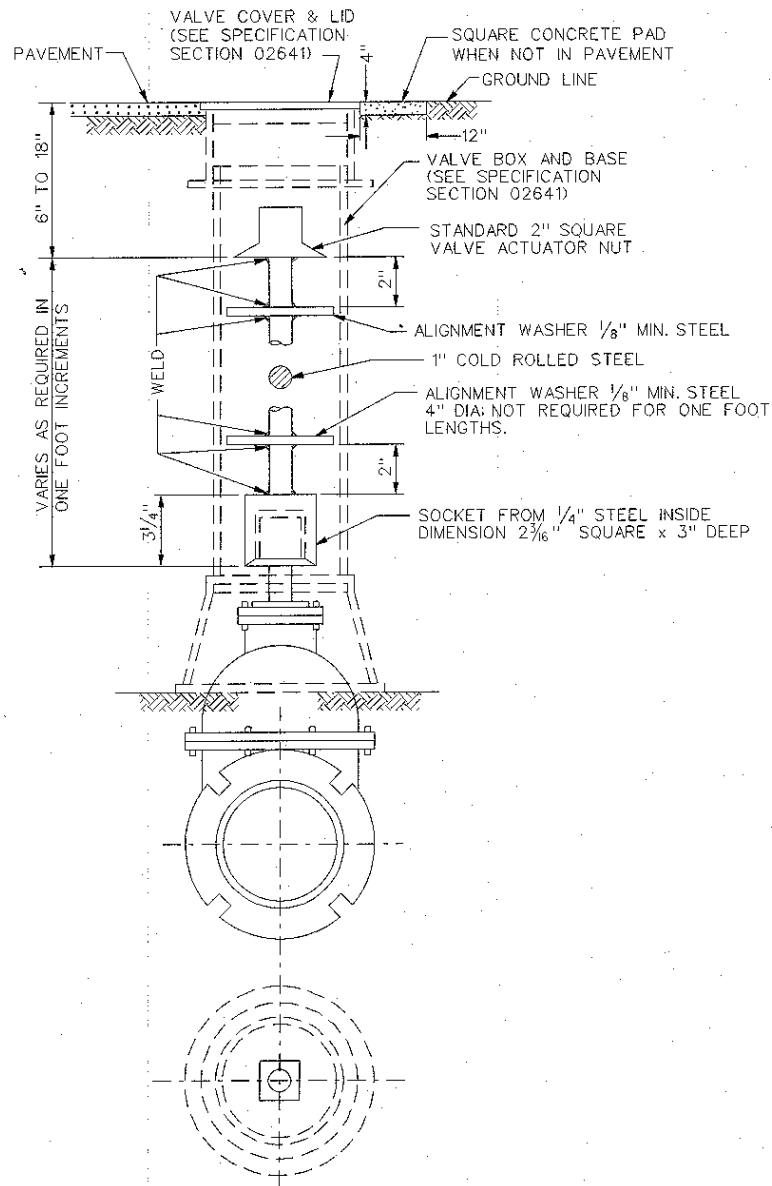

ACTUATOR NUT EXTENSION

WATER SERVICES DEPARTMENT CITY OF KANSAS CITY, MISSOURI

REVISED: FEBRUARY, 2003 CONSTRUCTION DETAIL DRAWING NO. 02641-4

SECTION 02645

HYDRANTS, BLOWOFF AND FLUSHING ASSEMBLIES

PART 1 GENERAL

1.1 Section Description

- A. This section provides for the installation of hydrants, and blowoff and flushing assemblies.

1.2 Section Includes

- A. Hydrants
- B. Blowoff and Flushing Assemblies

1.3 Related Sections

- A. Section 01016 – Water Mains Near Sewers
- B. Section 01300 – Submittals
- C. Section 01600 – Material and Equipment
- D. Section 02575 – Surface Restoration
- E. Section 02200 – Excavation and Trenching
- F. Section 02618 – Ductile Iron Pipe Water Main
- G. Section 02641 – Valves
- H. Section 02669 – Thrust Restraints
- I. Section 03001 – Concrete

1.4 Submittals

- A. Follow the procedures for submittals provided in Section 01300 – Submittals.
- B. Product Data: Submit catalog cuts and dimension data.

1.5 Quality Assurance

- A. The manufacturer shall be a company specializing in manufacturing the Products specified in this Section with minimum three years documented experience.

1.6 Delivery, Storage, and Handling

- A. Follow the provisions for delivery, storage, protection, and handling Products to and at site provided in Section 01600 - Material and Equipment.
- B. Accept units on site. Inspect for damage and inventory.

PART 2 PRODUCTS

2.1 Hydrants

- A. **General.** Hydrants shall be current Kansas City, MO. pattern hydrants manufactured especially for CITY. All hydrants shall be designed and manufactured in strict compliance with AWWA C-502 entitled "A.W.W.A. Standard for Dry-Barrel Fire Hydrants" unless otherwise specified.

- B. **Approved hydrants.** Only the following hydrants are approved.

Clow Medallion
M&H Regent 129i
Mueller Super Centurion 200
AVK QPL245 Nostalgic Style Fire Hydrant – Model 2760

- 1. No changes or modifications to the approved hydrant shall be made without prior written notice and written approval.
- C. **Specifications.** Hydrant bury will be measured from the bottom of the hydrant base to the bury line (finished grade line) and shall be five foot (5') bury unless otherwise specified.
 - 1. All hydrants shall be the traffic model type. Hydrants shall have one (1) pumper nozzle located in the horizontal plane. The upper barrel and lower barrel shall be sealed by an EPDM rubber gasket or O-ring.
 - 2. Hydrant base shall be provided with a mechanical joint inlet to accommodate 6-inch diameter ductile iron pipe, in accordance with A.N.S.I. A21.11 (AWWA Standard C-111, Rubber Gasket Joints for Cast Iron and Ductile Iron Pressure Pipe and Fittings"). The hydrant shall be supplied with necessary accessories for the mechanical joint.
 - 3. Main valve of the hydrant shall be 5-1/4 inch diameter compression type, which closes with water pressure.
 - 4. The operating nut shall be a truncated pentagon, 1-1/2 inches on the bottom, 1-7/16 inches on the top, with a finished height of 1-1/8 inches (**see attachment A**). The bonnet shall be so constructed that the opening nut shall not travel during opening and closing the hydrant. The bonnet shall house a Viton gasket or O-ring seal between the opening nut and the bonnet to prevent moisture and foreign material from entering the lubricant reservoir.

The bonnet shall also house Viton gasket or O-ring seal between the bonnet and the upper stem to retain the lubricant in the reservoir.

5. The hydrant shall be supplied with a tamper resistant shield for the operating nut. The shield shall be in accordance with the attached drawing, **Attachment B**.
6. The hydrant shall open by turning the operating nut to the right (in a clockwise direction when viewing the hydrant from above).
7. The pumper nozzle threads shall be in accordance with the Federal Screw Thread Standard H28, Section 10, American National Hose Coupling and Fire Hose Coupling Threads. The pumper nozzle shall have right-hand threads and have a 4-inch nominal diameter with 4 (four) threads per inch. The nozzle threads shall be lightly greased from factory with a suitable food grade lubricant.
8. Nozzle cap shall be cast iron and shall be furnished with a synthetic rubber installed in a retaining groove in the inside of the cap. The dimensions and shape of the nozzle cap nut shall be the same as the operating nut as described in Section 4 above, except with a finished height of 1-inch.
9. The exterior of the hydrant above the bury line, nozzle caps, and the bonnet shall be powder coated with epoxy or Triglycidyl Isocyanurate (TGIC) polyester. If epoxy powder is used, it shall be top-coated with a UV resistant, high-gloss acrylic polyurethane paint. **The barrel section of the hydrant shall be gloss International Orange. The bonnet section and nozzle caps shall be gloss Black.** The exterior of the hydrant below the bury line shall be coated with an asphalt varnish with a film thickness of at least 10 mils.
10. All non-thread, non-machines interior surfaces of the hydrant base shall be coated with a wet-applied NSF 61 certified white potable epoxy (such as Tnemec 20-AA90) or powder coated with an NSF 61 certified white epoxy. The exterior of the hydrant base shall also be epoxy coated.
11. Hydrant extensions (spool pieces), if requested and approved by the Water Services Department, shall be a complete assembly allowing for the hydrant's height to be adjusted in six (6) inch increments. The assembly shall be furnished with instructions and all required accessories necessary to adjust the hydrant's height and maintain the hydrant's traffic feature. Hydrant extensions shall be International Orange in color and shall be coated in accordance with Section 9.
12. All external hardware shall be 304 or 316 stainless steel.
13. The lower hydrant stem from the break-away coupling to the main valve and any attaching hardware securing the main valve assembly to the lower stem shall be 304 or 316 stainless steel. Any cross pins securing any part of the main valve assembly or break away stem coupler shall be 420 stainless steel.

The lower stem nut may be integral to the lower valve plate or main valve assembly.

14. Main valve assemblies shall be of either three-piece (upper valve plate, main valve seat, lower valve plate) or one-piece EPDM encapsulated ductile iron design. The lower valve plate of three-piece design main valve assemblies shall be powder coated with an NSF 61 certified epoxy.
 15. The upper surface of the seat ring shall have raised lugs allowing for positive engagement of a hydrant disassembly tool. The raised lugs shall be of sufficient design to allow for the removal of the seat ring.
- D. **Shop Drawing.** Prior to manufacturing the hydrants, the manufacture shall submit three (3) sets of detailed shop drawings for written approval.
- E. **Packaging.** All hydrants shall be bundled in a group no larger than three (3) hydrants wide by three (3) hydrants high. All hydrants shall be shipped with the hydrant base inlet pointing down. All hydrants shall be separated wood framing adequate to prevent the hydrants from touching the ground or each other. Binding the hydrants together shall be a band or wrap adequate to per handling of the hydrant bundles with a crane truck or a forklift. All hydrants shall be delivered with the hydrant nozzle cap installed.

2.2 Blowoff and Flushing Assemblies

- A. Mechanical joint plug: Drilled and tapped for 2-inch standard pipe threads.
- B. Elbows and outlet pipe: standard weight galvanized pipe and fittings.
- C. All discharge piping shall have a 2" PVC cap on top.
- D. Blowoff Assembly:

PART 3 EXECUTION

3.1 Preparation

- A. The areas around each hydrant valve shall be thoroughly compacted to prevent settlement of these areas.
- B. The weep holes of the hydrant shall be kept clear and free to drain with 1-½ C.Y. of coarse stone (¾" clean minimum).

3.2 Installation

- A. Hydrant shall stand plumb and when placed behind curbs, the centerline of the hydrant shall be at least twenty-four (24) inches from the back of the curb or 4' from the edge of pavement when there is no curb. Hydrant shall not be set in a drainage ditch.

- B. Hydrant shall be rotated so as to have the nozzle facing the street or rotated to face any direction as required by the CITY.
- C. Hydrants are to be installed with mechanical joint anchoring fittings or approved restraint devices. Refer to Section 02669.
- D. Hydrants are to be installed in accordance with Details 02645-1, 02645-2, and 02645-3.
- E. After installation and before hydrants are placed in service, Contractor shall field apply two separate coats of all surface spray enamel paint, in accordance with paint manufacturers recommendations, to completely cover each hydrant dome in accordance with the following:

Hydrants connected to 12" or larger mains
Krylon 5816 Green (or approved equal)

Hydrants connected to mains smaller than 6"
Krylon 5814 Red (or approved equal)

Hydrants connected to 6" or larger mains, but smaller than 12" mains.
Krylon 5812 Black (or approved equal)

This color-coding is intended to provide firefighters and other emergency workers a permanent, quick visual reference to indicate the size of water main connected to each hydrant.

- F. Blow off and flushing assemblies are to be installed in accordance with Details 02645-4, 02645-5, and 02645-6.

END OF SECTION

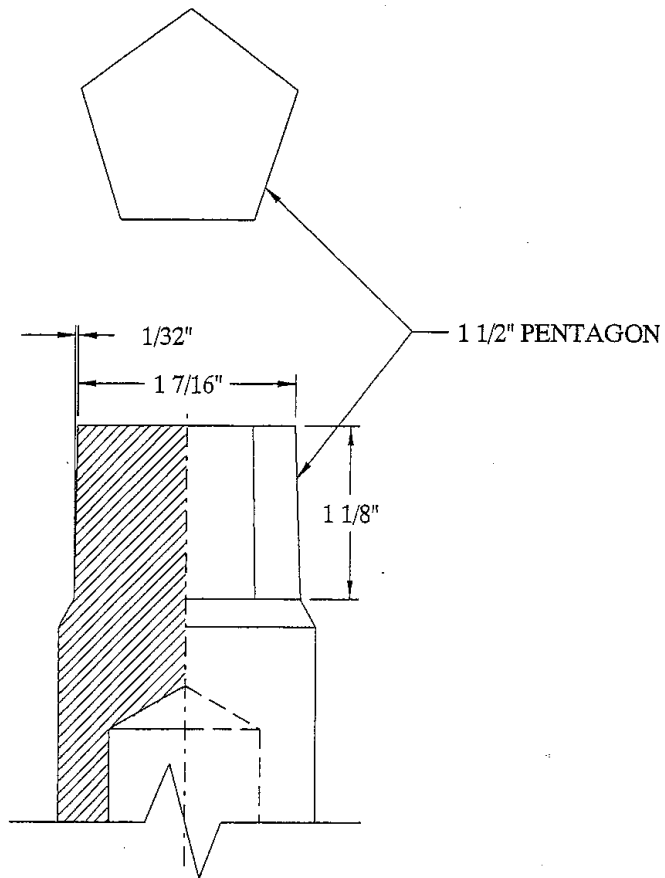

SCALE 1"=1"

OPERATING NUT (STEM NUT)
ATTACHMENT A

WATER SERVICES DEPARTMENT
 CITY OF KANSAS CITY, MISSOURI

ENGINEERING DIVISION

DRAWING NO. 18015

DESIGNED BY: B. SCHROEDER

APPROVED BY: E. RYSER

DETAILED BY: M. DeMAY

DATE: 25-MAR-1997

1 OF 2

NO.	DATE	BY	NATURE
REVISIONS			

RAISED DIRECTION ARROW
(OPEN-CLOCKWISE)

NOTE:

MANUFACTURERS NAME SHALL BE
CAST IN RAISED LETTERS, 1/4" HIGH,
ON FACE OPPOSITE ARROW

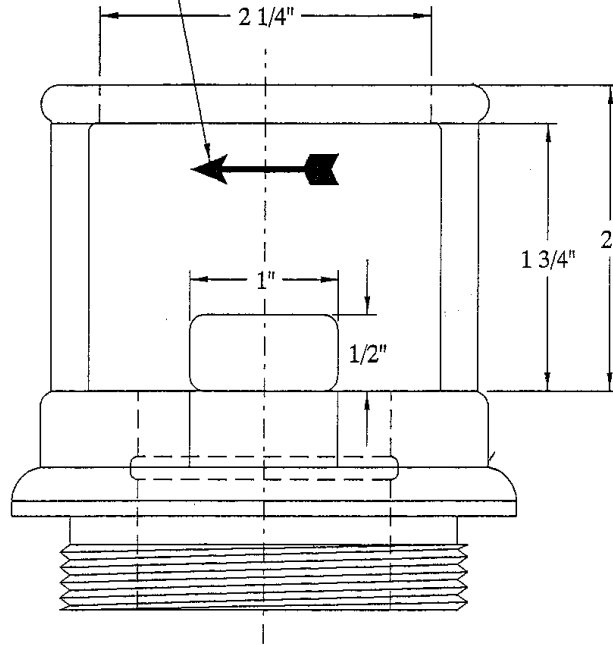

TOLERANCES:
CAST CORNERS
ROUNDS +/- 1/16"
FILLETS +/- 1/16"

BREAK CORNERS
APPROX. .005" R (TYP.)

MATERIAL:
DUCTILE IRON A.S.T.M.
536 GRADE 60-40-18
OR A.S.T.M. A-445

SCALE 1"=1"

NO.	DATE	BY	NATURE
REVISIONS			

SECURITY STYLE HOLD DOWN NUT
ATTACHMENT B

WATER SERVICES DEPARTMENT
CITY OF KANSAS CITY, MISSOURI

ENGINEERING DIVISION

DRAWING NO. **18015**

DESIGNED BY: B. SCHROEDER APPROVED BY: E. RYSER

DETAILED BY: M. DeMAY DATE: 25-MAR-1997

2 OF 2

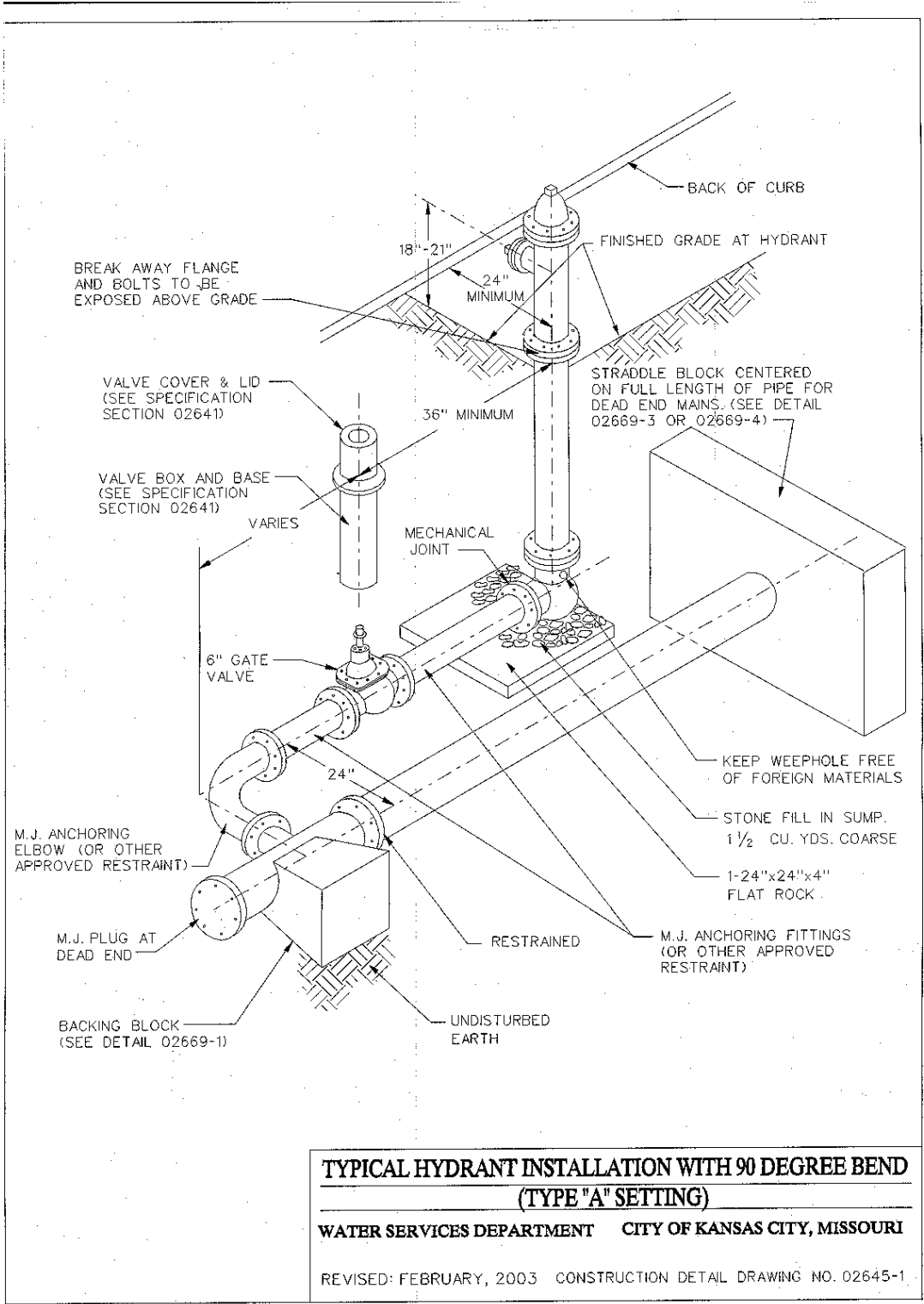

**TYPICAL HYDRANT INSTALLATION WITH 90 DEGREE BEND
(TYPE "A" SETTING)**

WATER SERVICES DEPARTMENT CITY OF KANSAS CITY, MISSOURI

REVISED: FEBRUARY, 2003 CONSTRUCTION DETAIL DRAWING NO. 02645-1

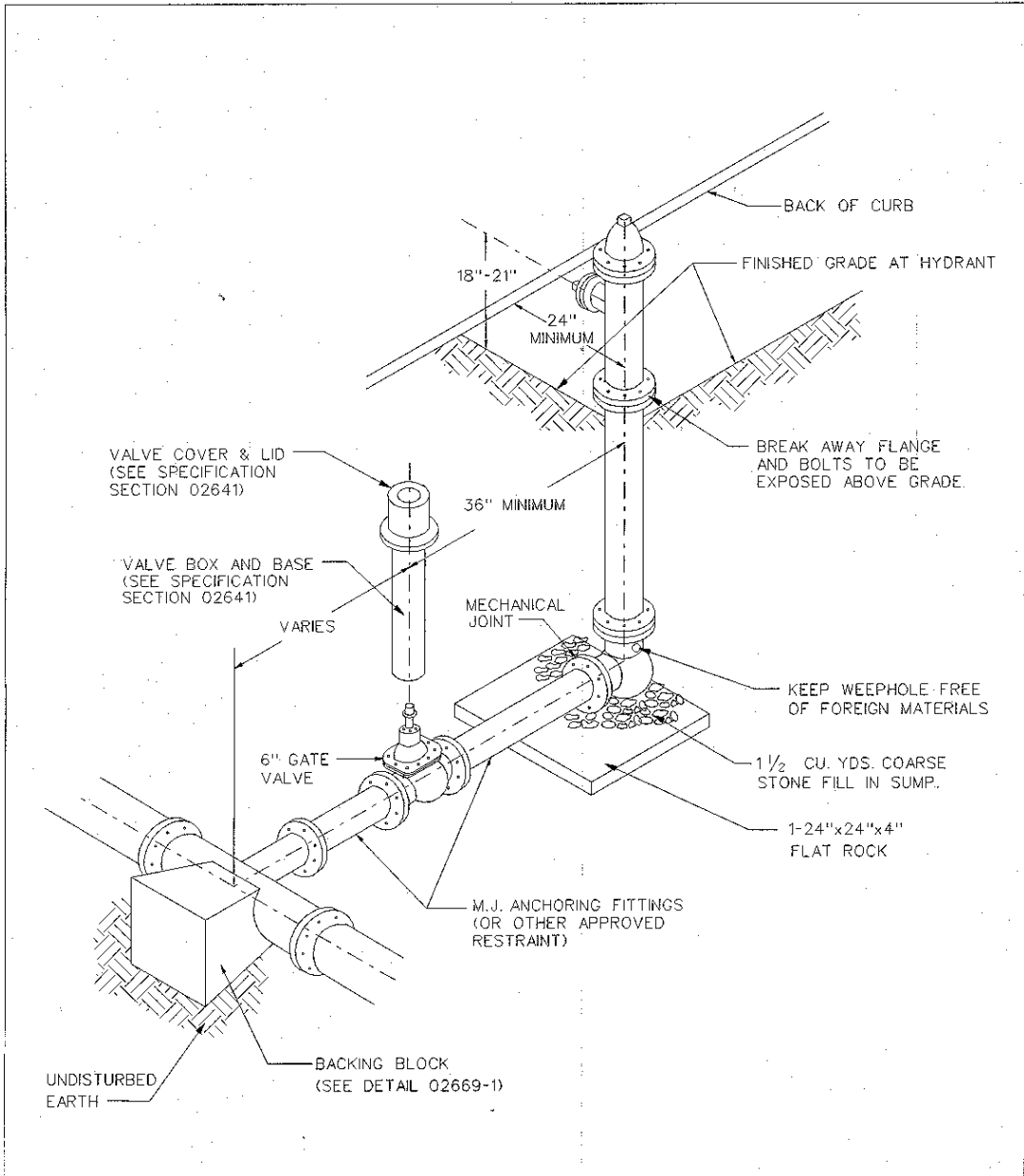

NOTE:
 1. VALVE BOX AND BASE CAN BE ONE PIECE, OR TWO PIECES AS SPECIFIED IN SECTION 02641.

STRAIGHT SET HYDRANT INSTALLATION
(TYPE "B" SETTING)

WATER SERVICES DEPARTMENT CITY OF KANSAS CITY, MISSOURI

REVISED: FEBRUARY, 2003 CONSTRUCTION DETAIL DRAWING NO. 02645-2

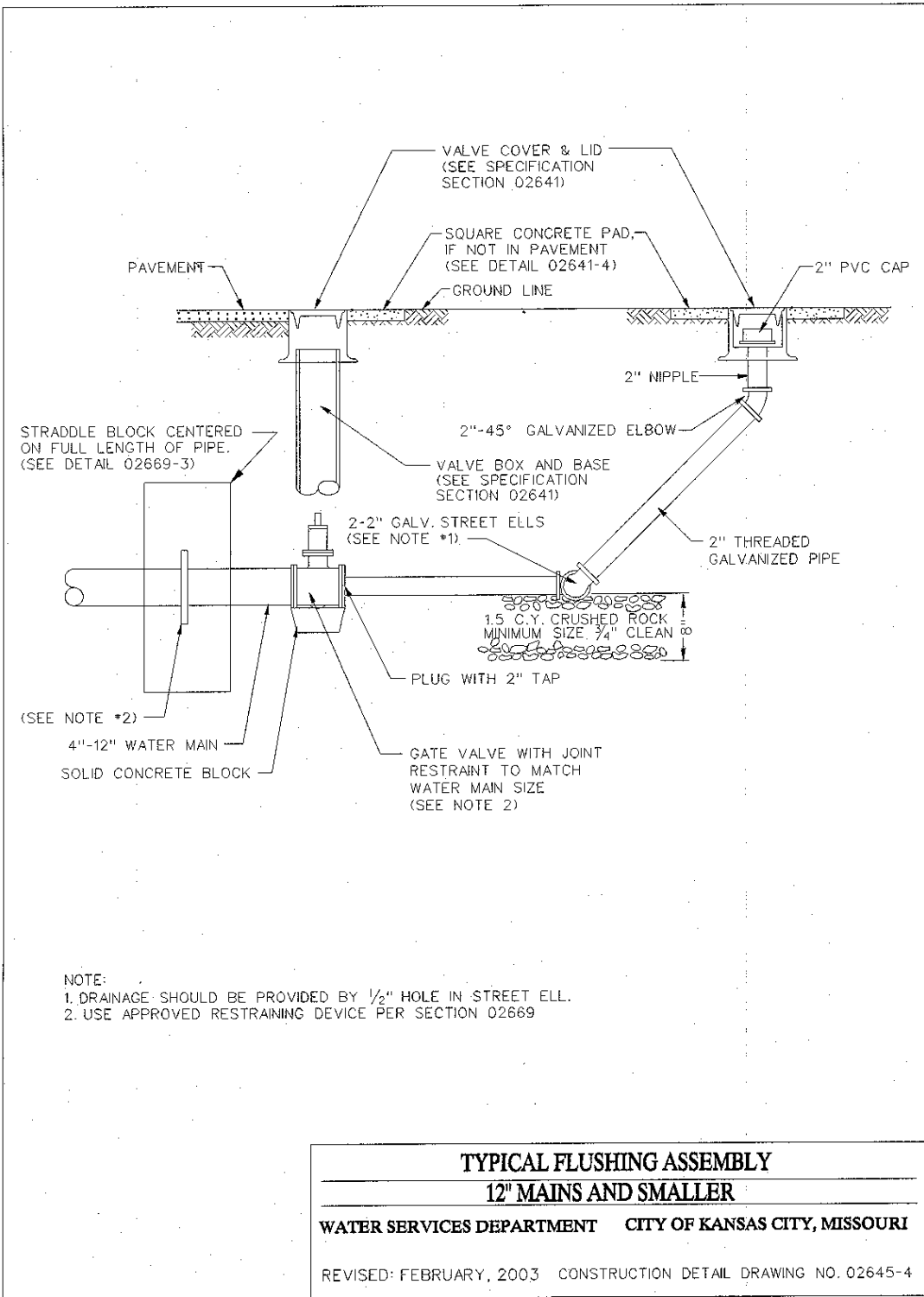

**TYPICAL FLUSHING ASSEMBLY
12" MAINS AND SMALLER**

WATER SERVICES DEPARTMENT CITY OF KANSAS CITY, MISSOURI

REVISED: FEBRUARY, 2003 CONSTRUCTION DETAIL DRAWING NO. 02645-4

SECTION 02669
THRUST RESTRAINTS

PART 1 GENERAL

1.1 Section Description

- A. This section provides for the required restraining devices to limit movement of pipe and fittings.

1.2 Section Includes

- A. Restrained Joints
- B. Concrete Blocking

1.3 Related Sections

- A. Section 01300 – Submittals
- B. Section 01600 – Material and Equipment
- C. Section 02200 – Excavation and Trenching
- D. Section 02618 – Ductile Iron Pipe Water Main
- E. Section 02645 – Hydrants and Blowoff and Flushing Assemblies
- F. Section 03001 – Concrete
- G. Section 03200 – Concrete Reinforcement

1.4 Submittals

- A. Follow the procedures for submittals provided in Section 01300 - Submittals.
- B. Submit shop drawings and descriptive details showing the size, length, and location of each fitting and adjacent pipe, and the details of all anchorage and harnessing proposed.

1.5 Quality Assurance

- A. The manufacturer shall be a company specializing in manufacturing the Products specified in this section with minimum three (3) years documented experience.

1.6 Delivery, Storage and Handling

- A. Follow the provisions for the delivery, storage, protection and handling products to and at site provided in Section 01600 - Material and Equipment.

PART 2 PRODUCTS

2.2 Restrained Joints

- A. Restrained Push-on joints for ductile iron pipe and fittings: American "Flex-Ring", "Fast-Grip", Clow "Super-Lock"; U.S. Pipe "TR Flex" or "Field Lok", or Griffin "Snap-Lok".
- B. Restrained Mechanical Joints: EBAA Iron "Mega-Lug" or Ford uni-flange. "Mega-Lug" shall not be used on plain end fittings.
- C. Restrained joint fittings: One Bolt
- D. Restrained joints for PCCP shall be as specified in Section 02619.

2.2 Concrete Blocking

- A. Concrete shall be as per Section 03001.

PART 3 EXECUTION

3.3 Reaction Anchorage and Blocking

- A. Piping and fittings with push-on or mechanical joints, or similar joints subject to internal pressure shall be blocked, anchored, or harnessed to preclude separation of joints. All push-on and mechanical joint bends deflecting 11-1/4 degrees or more shall be provided with suitable blocking, anchors, joint harness, or other acceptable means for preventing movement of the pipe caused by internal pressure.
- B. Concrete blocking shall extend from the fitting to solid undisturbed earth and shall be installed so that all joints and bolts are accessible for repair.
- C. The dimensions of concrete blocking shall be as indicated on Construction Detail Drawings numbered 02669-1, 02669-2, 02669-3, 02669-4 and 02669-5. If support against undisturbed earth cannot be obtained, restrain joints as specified in 3.2, Restrained Length (length shall be approved by CITY).
- D. A maximum of eight (8) inches of backfill material may be placed over concrete arch encasement or concrete blocking after the initial set, to aid in curing. No additional backfill shall be placed over arch encasement or blocking until the concrete has been in place for at least one (1) day.

- E. Reaction blocking, anchorages, or other supports for fittings installed in fills or other unstable ground, above grade, or exposed within structures, shall be provided as required by the Construction Detail Drawings and as directed by the CITY.
- F. All clamps, rods, bolts, and other metal accessories used in reaction anchorages, or joint harness subject to submergence or contact with earth or other fill material and not encased in concrete shall be protected from corrosion by two coats of approved coal tar applied in the field to clean, dry metal surfaces. The first coat shall be dry and hard before the second coat is applied. Metal surfaces exposed above grade or within structures shall be painted with one prime coat and two finish coats of a paint acceptable to the CITY.

END OF SECTION

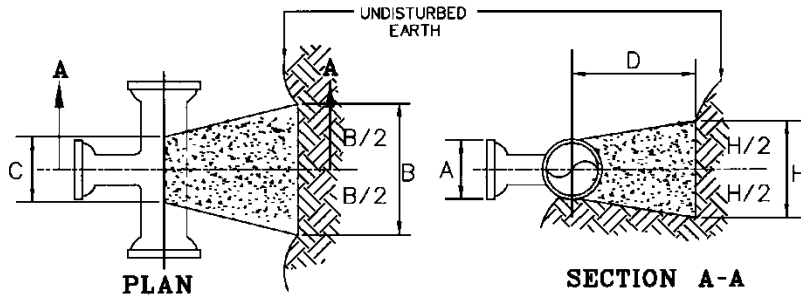

- NOTES:
1. BACKING BLOCKS FOR PIPING SIZES UP THROUGH 12-INCH ARE BASED ON WORKING PRESSURE OF 175 P.S.I. PLUS 50% SURGE.
 2. BACKING BLOCKS FOR PIPING SIZES 16-INCH THROUGH 24-INCH ARE BASED ON A WORKING PRESSURE OF 150 P.S.I. PLUS 50% SURGE.
 3. THE PROJECT DESIGN PROFESSIONAL IS RESPONSIBLE FOR THE DESIGN OF THRUST BLOCKS. THE BLOCK SIZES SPECIFIED HEREIN ARE MINIMUM SIZES, BASED ON SOIL RESISTANCE OF 2,000 POUNDS PER SQUARE FOOT. WHERE SOFTER SOILS MAY BE ENCOUNTERED, THE PROJECT DESIGN PROFESSIONAL MUST PROVIDE A DESIGN FOR REVIEW BY THE DEPARTMENT.
 4. SEE SECTION 03001 FOR CONCRETE SPECIFICATIONS.
 5. CONSTRUCT FORMS IN ACCORDANCE WITH SECTION 03100.

BRANCH OR PLUG SIZE A	B (in.)	C (in.)	D (in.)	H (in.)	REQUIRED BEARING AREA (SQ.FT.)	ESTIMATED CONCRETE REQ. CYD.
6"	46	6	20	24	7.4	0.24
8"	60	8	26	32	13.2	0.55
12"	114	12	51	38	29.7	2.45
16"	126	16	55	52	45.2	4.00
20"	140	20	60	72	70.7	6.74
24"	184	24	80	80	101.8	13.00
30"	230	30	100	100	159.0	25.61

TYPICAL BACKING BLOCKS FOR TEES AND PLUGS
2,000 POUNDS PER SQUARE FOOT SOIL RESISTANCE
 WATER SERVICES DEPARTMENT CITY OF KANSAS CITY, MISSOURI
 REVISED: July, 2006 CONSTRUCTION DETAIL DRAWING NO. 02669-1

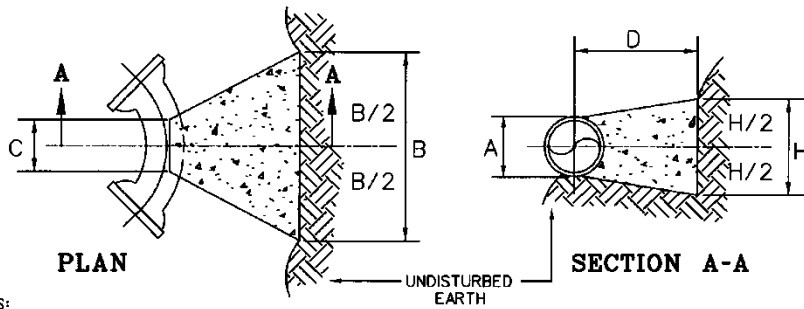

NOTES:

1. BACKING BLOCKS FOR PIPING SIZES UP THROUGH 12-INCH ARE BASED ON WORKING PRESSURE OF 175 P.S.I. PLUS 50% SURGE.
2. BACKING BLOCKS FOR PIPING SIZES 16-INCH THROUGH 24-INCH ARE BASED ON A WORKING PRESSURE OF 150 P.S.I. PLUS 50% SURGE.
3. THE PROJECT DESIGN PROFESSIONAL IS RESPONSIBLE FOR THE DESIGN OF THRUST BLOCKS. THE BLOCK SIZES SPECIFIED HEREIN ARE MINIMUM SIZES, BASED ON SOIL RESISTANCE OF 2,000 POUNDS PER SQUARE FOOT. WHERE SOFTER SOILS MAY BE ENCOUNTERED, THE PROJECT DESIGN PROFESSIONAL MUST PROVIDE A DESIGN FOR REVIEW BY THE DEPARTMENT.
4. SEE SECTION 03001 FOR CONCRETE SPECIFICATIONS.
5. CONSTRUCT FORMS IN ACCORDANCE WITH SECTION 03100.

1 1/4 DEGREE BENDS						
PIPE SIZE A	B (in.)	C (in.)	D (in.)	H (in.)	REQUIRED BEARING AREA (SQ.FT.)	ESTIMATED CONCRETE REQ. CYD.
6"	18	6	12	12	1.5	0.03
8"	28	8	12	14	2.6	0.06
12"	38	12	13	22	5.8	0.14
16"	50	16	17	26	8.9	0.28
20"	64	20	22	32	13.9	0.58
24"	76	24	26	38	20.0	0.97
30"	95	30	33	48	31.2	1.90

22 1/2 DEGREE BENDS						
PIPE SIZE A	B (in.)	C (in.)	D (in.)	H (in.)	REQUIRED BEARING AREA (SQ.FT.)	ESTIMATED CONCRETE REQ. CYD.
6"	28	6	12	16	2.9	0.06
8"	34	8	13	22	5.1	0.11
12"	56	12	22	30	11.6	0.43
16"	72	16	28	36	17.7	0.85
20"	86	20	33	46	27.6	1.54
24"	106	24	41	54	39.7	2.77
30"	136	30	53	66	62.1	5.60

45 DEGREE BENDS						
PIPE SIZE A	B (in.)	C (in.)	D (in.)	H (in.)	REQUIRED BEARING AREA (SQ.FT.)	ESTIMATED CONCRETE REQ. CYD.
6"	38	6	16	22	5.7	0.15
8"	54	8	23	28	10.1	0.39
12"	82	12	35	40	22.7	1.28
16"	100	16	42	50	34.6	2.37
20"	130	20	55	60	54.1	4.83
24"	152	24	64	74	77.9	8.10
30"	196	30	83	90	121.7	16.49

90 DEGREE BENDS						
PIPE SIZE A	B (in.)	C (in.)	D (in.)	H (in.)	REQUIRED BEARING AREA (SQ.FT.)	ESTIMATED CONCRETE REQ. CYD.
6"	60	6	27	26	10.5	0.46
8"	84	8	38	32	18.7	1.12
12"	126	12	57	44	42.0	3.47
16"	160	16	72	58	64.0	7.36
20"	200	20	90	72	100.0	14.27
24"	242	24	109	86	143.9	24.98
30"	324	30	147	100	224.9	52.46

TYPICAL BACKING BLOCKS FOR HORIZONTAL BENDS
2,000 POUNDS PER SQUARE FOOT SOIL RESISTANCE

WATER SERVICES DEPARTMENT CITY OF KANSAS CITY, MISSOURI

REVISED: JULY, 2006 CONSTRUCTION DETAIL DRAWING NO. 02669-2

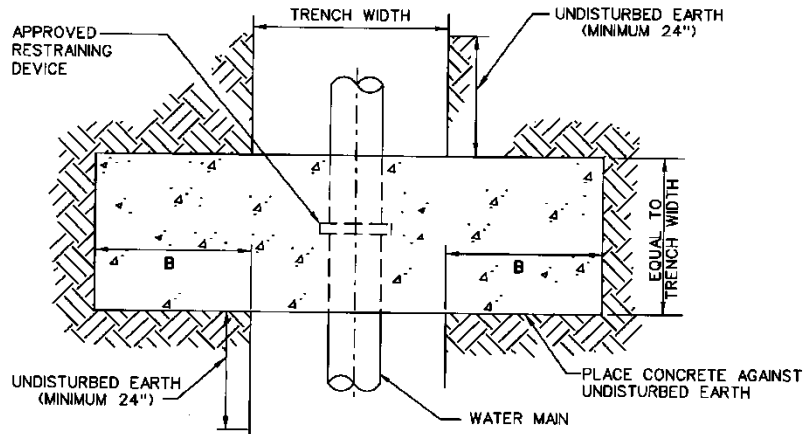

PLAN

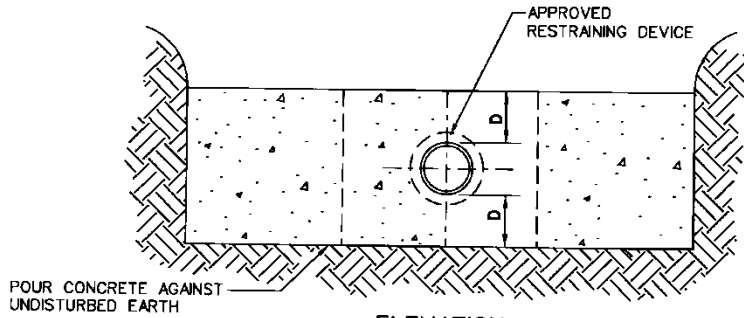

ELEVATION

- NOTES:
1. STRADDLE BLOCKS ARE SIZED FOR 175 P.S.I. LINE PRESSURE 50% SURGE.
 2. THE PROJECT DESIGN PROFESSIONAL IS RESPONSIBLE FOR DESIGN OF STRADDLE BLOCKS. THE SIZES SPECIFIED HEREIN ARE MINIMUM SIZES BASED ON SOIL RESISTANCE OF 2,000 POUNDS PER SQUARE FOOT. WHERE SOFTER SOILS MAY BE ENCOUNTERED, THE PROJECT DESIGN PROFESSIONAL MUST PROVIDE A DESIGN FOR REVIEW BY THE DEPARTMENT.
 3. SEE SECTION 03001 FOR CONCRETE SPECIFICATIONS.
 4. CONSTRUCT FORMS IN ACCORDANCE WITH SECTION 03100.

PIPE SIZE	TRENCH WIDTH (in.)	B (in.)	D (in.)	REQUIRED BEARING AREA (SQ. FT.)	ESTIMATED CONCRETE REQ. CYD.
6"	30	24	9	7.4	0.9
8"	32	30	12	13.2	1.5

TYPICAL STRADDLE BLOCK FOR 6 AND 8 INCH PIPE
2,000 POUNDS PER SQUARE FOOT SOIL RESISTANCE

WATER SERVICES DEPARTMENT CITY OF KANSAS CITY, MISSOURI

REVISED: JULY, 2006 CONSTRUCTION DETAIL DRAWING NO. 02669-3

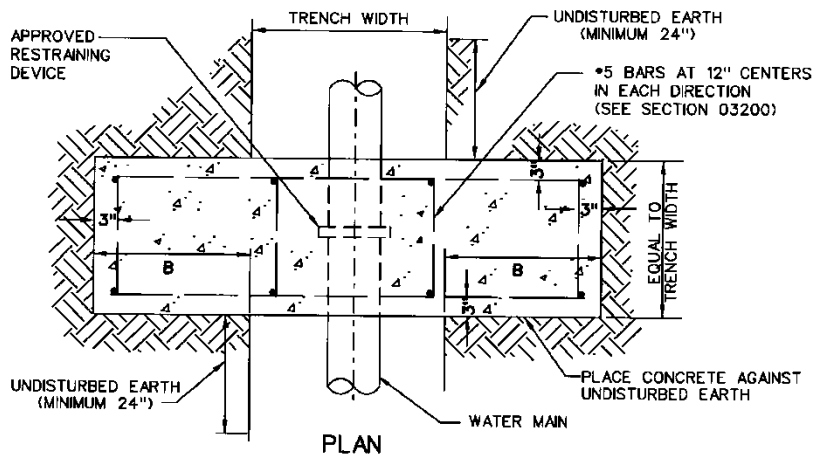

PLAN

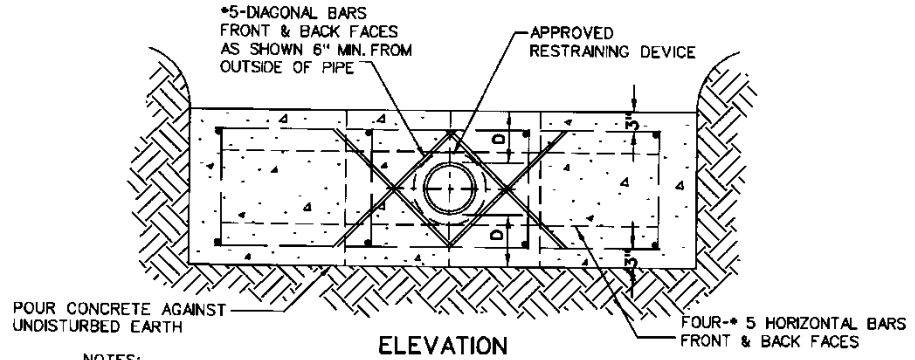

ELEVATION

- NOTES:
1. STRADDLE BLOCKS 12" ARE SIZED FOR 175 P.S.I., AND 16" & LARGER ARE SIZED FOR 150 P.S.I. LINE PRESSURE 50% SURGE.
 2. THE PROJECT DESIGN PROFESSIONAL IS RESPONSIBLE FOR DESIGN OF STRADDLE BLOCKS. THE SIZES SPECIFIED HEREIN ARE MINIMUM SIZES BASED ON SOIL RESISTANCE OF 2,000 POUNDS PER SQUARE FOOT. WHERE SOFTER SOILS MAY BE ENCOUNTERED, THE PROJECT DESIGN PROFESSIONAL MUST PROVIDE A DESIGN FOR REVIEW BY THE DEPARTMENT.
 3. SEE SECTION 03001 FOR CONCRETE SPECIFICATIONS.
 4. CONSTRUCT FORMS IN ACCORDANCE WITH SECTION 03100.

PIPE SIZE	TRENCH WIDTH (in.)	B (in.)	D (in.)	REQUIRED BEARING AREA (SQ. FT.)	ESTIMATED CONCRETE REQ. CYD.
12"	34	51	15	29.7	4.1
16"	40	48	26	45.2	7.8

TYPICAL STRADDLE BLOCK FOR 12 & 16 INCH PIPE
2,000 POUNDS PER SQUARE FOOT SOIL RESISTANCE

WATER SERVICES DEPARTMENT CITY OF KANSAS CITY, MISSOURI

REVISED: JULY, 2006 CONSTRUCTION DETAIL DRAWING NO. 02669-4

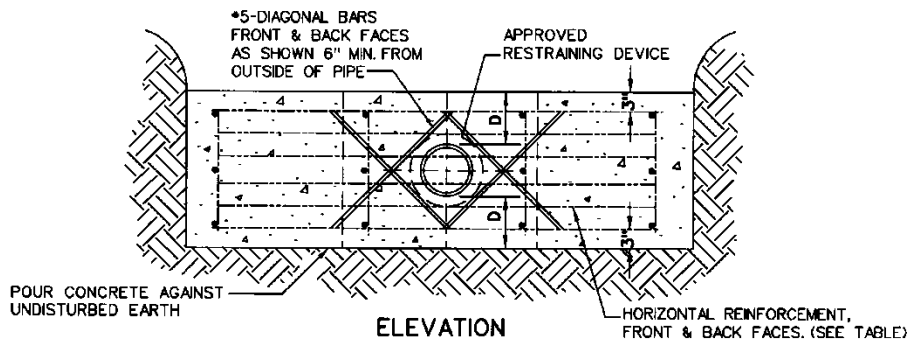
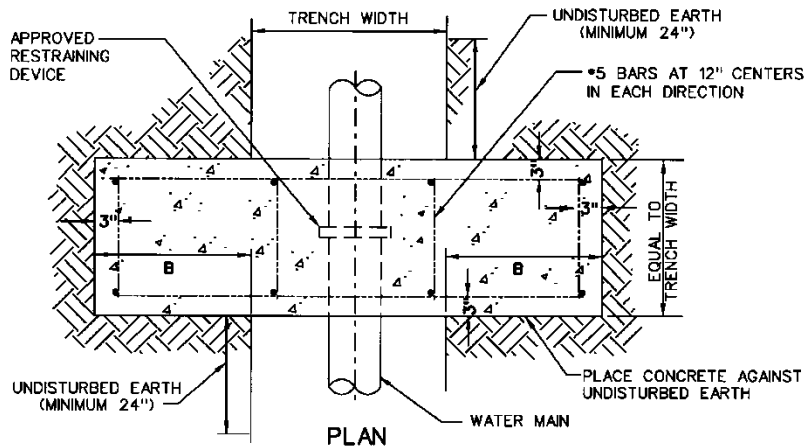

NOTES:

1. STRADDLE BLOCKS ARE SIZED FOR 150 P.S.I. LINE PRESSURE 50% SURGE.
2. THE PROJECT DESIGN PROFESSIONAL IS RESPONSIBLE FOR DESIGN OF STRADDLE BLOCKS. THE SIZES SPECIFIED HEREIN ARE MINIMUM SIZES BASED ON SOIL RESISTANCE OF 2,000 POUNDS PER SQUARE FOOT. WHERE SOFTER SOILS MAY BE ENCOUNTERED, THE PROJECT DESIGN PROFESSIONAL MUST PROVIDE A DESIGN FOR REVIEW BY THE DEPARTMENT.
3. SEE SECTION 03001 FOR CONCRETE SPECIFICATIONS.
4. CONSTRUCT FORMS IN ACCORDANCE WITH SECTION 03100.

PIPE SIZE	BAR SIZE	NO. OF BARS (each face)	TRENCH WIDTH (in.)	B (in.)	D (in.)	REQUIRED BEARING AREA (SQ. FT.)	ESTIMATED CONCRETE REQ. CYD.
20"	*5	5	44	71	26	70.7	12.3
24"	*6	6	48	92	28	101.8	18.6
30"	*7	6	60	115	35	159.0	36.4

**TYPICAL STRADDLE BLOCK FOR 20, 24, & 30 INCH PIPE
2,000 POUNDS PER SQUARE FOOT SOIL RESISTANCE**

WATER SERVICES DEPARTMENT CITY OF KANSAS CITY, MISSOURI

REVISED: JULY, 2006 CONSTRUCTION DETAIL DRAWING NO. 02669-5

SECTION 02675

WATER MAIN TESTING, DISINFECTION AND DECHLORINATION

PART 1 GENERAL

1.1 Section Description

- A. This section provides for the required procedure for the water main testing, disinfection, and dechlorination prior to placing water mains in service.

1.2 Section Includes

- A. Corporation Cocks
- B. Hydrostatic Testing
- C. Disinfection of Water Mains

1.3 Related Sections

- A. Section 01000 – General Requirements
- B. Section 01300 – Submittals
- C. Section 01600 – Material and Equipment
- D. Section 02618 – Ductile Iron Pipe
- E. Section 02641 – Valves
- F. Section 02645 – Hydrants, Blowoff and Flushing Assemblies

1.4 References

- A. AWWA C651 - Standards for Disinfecting Water Mains.

1.5 Submittals

- A. Follow the procedures for submittals provided in Section 01300 – Submittals.
- B. Certificate: The Contractor shall certify in writing that cleanliness of water distribution system meets or exceeds specified requirements.
- C. At the completion of the disinfection procedures, Contractor shall prepare a Disinfection Report; including:
 - 1. Type and form of disinfectant used.
 - 2. Date and time of disinfectant injection start and time of completion.

3. Test locations.
 4. Initial and 24 hour disinfectant residuals (quantity in treated water) in parts per million for each outlet tested.
 5. Date and time of post disinfectant flushing start and completion.
 6. Disinfectant residual after flushing in parts per million for each outlet tested.
- C. Contractor shall provide, at their expense, water sample collection and testing by a MoDNR approved laboratory which shall prepare a Bacteriological Report; including:
1. Date issued, project name, and testing laboratory name, address, and telephone number.
 2. Time and date of water sample collection, and testing.
 3. Name of person collecting samples.
 4. Test locations.
 5. Initial and 24 hour disinfectant residuals in parts per million for each outlet tested.
 6. Coliform bacteria test results for each outlet tested.
 7. Certification that water conforms, or fails to conform, to bacterial standards of the Missouri Department of Natural Resources.
 8. Bacteriologist's signature and authority.

1.6 Quality Assurance

- A. Work shall be performed in accordance with AWWA C651.

PART 2 PRODUCTS

2.1 Corporation Cocks

- A. The Contractor will furnish and install a three-fourth inch (3/4") Corporation cock to be used in the testing and disinfection of each new main. The location of these corporation cocks shall be as directed by the CITY.
- B. After the line has been tested and prior to placing the main in service, the Contractor shall remove the corporation cock and replace it with a tapered brass plug.

PART 3 EXECUTION

3.1 Hydrostatic Testing

A. General

1. The entire main shall be tested (pressure test and allowable leakage test) immediately after construction as directed and witnessed by the CITY.
2. With approval of the CITY, the pressure test and leakage test may be conducted simultaneously. However, should the Contractor be granted permission to make both tests simultaneously, the required test pressure shall be equal to or greater than that for pressure tests as specified below.

B. Pressure Test

1. After the trench has been backfilled, the test connections made and the main filled with water, a minimum pressure of not less than the normal operating pressure (for the lowest point on the line) plus 50% for surge but in no case less than 160 psi for 12" and smaller mains and 225 psi for 16" and larger mains, unless otherwise stated, shall be maintained on the new water main for at least two (2) hours.
2. The Contractor shall furnish all pumps, piping, gauges, labor and other materials and services necessary to bring the main up to the specified test pressure.
3. All exposed pipe, fittings, valves, hydrants and joints shall be inspected by the CITY and all evidence of moisture appearing on the surface of the ground during the test shall be investigated by the Contractor by excavation where the pipe has been covered with backfill.
4. All defective pipe, fittings, valves or hydrants discovered during the pressure test shall be removed and replaced by the Contractor and the pressure test shall be repeated until satisfactory to the CITY.
5. The Contractor shall furnish and install all temporary blow-off assemblies, fittings, thrust blocks, and restraining devices required for temporary connections for flushing, pressure testing, chlorination, and de-chlorination of water mains.

C. Leakage Test

1. An allowable leakage test shall be conducted after the pressure test has been satisfactorily completed. The Contractor shall maintain a minimum pressure in the new water main of 150 psi (or a minimum of 10 psi greater than the normal operating pressure of the system, if the normal operating pressure is lower than 140 psi) for the lowest point on the line for at least two (2) hours.

2. Leakage shall be defined as the quantity of water that must be supplied into the newly laid pipe to maintain the specified leakage test pressure after the air has been expelled and the pipe has been filled with water.
3. No water main, or section thereof will be accepted if and while it has a leakage rate in excess of that determined by the following formula:

$$L = .0000075 SD(P)^{1/2} / 2$$

Where:

L = Maximum permissible leakage in gallons for two hours.

S = Length of pipe tested, in feet.

D = Nominal internal diameter of the water main being tested in inches.

P = Average test pressure in psi in the water main being tested.

4. Should the actual leakage exceed the allowable leakage, the test pressure shall be maintained for an additional period of time as directed by the CITY so that the leakage location may be detected.

3.2 Disinfection of Water Mains

A. General

1. After completion of hydrostatic testing the Contractor shall flush and disinfect the entire main under the direction of CITY.
2. The Contractor shall prepare the main for disinfection by exposing the pipe at all entry points where the chlorine will be introduced into the pipe and installing temporary blow-offs at all discharge ends.
3. Continuous feed method of chlorination is required. The slug method of chlorination may be used only when directed by CITY.

B. Continuous Feed-Method

1. Water supplied from an approved source of supply shall be made to flow at a constant, measured rate into the new water main.
2. At a point not more than 10 ft downstream from the beginning of the new main, water entering the new main shall receive a dose of chlorine fed at a constant rate such that the water will have not less than 60 mg/L free chlorine. To ensure that this concentration is achieved, the chlorine concentration should be measured at regular intervals.
3. As an optional procedure, water used to fill the new water main during the application of chlorine shall be supplied through a temporary connection. This temporary connection shall be installed with an appropriate cross-

connection control device for backflow protection of the active distribution system. Chlorine application shall not cease until the entire main is filled with heavily chlorinated water. The chlorinated water shall be retained in the main for at least 24 hours, during which time all valves and hydrants shall be operated to ensure disinfection of the appurtenances. At the end of this 24-hour period, the treated water in all portions of the main shall have a residual of at least 45 mg/L free chlorine.

4. The preferred equipment for applying liquid chlorine is a solution-feed, vacuum-operated chlorinator and a booster pump. The vacuum-operated chlorinator mixes the chlorine gas in solution water; the booster pump injects the chlorine-gas solution into the main to be disinfected. All connections shall be checked for tightness before the solution is applied to the main.
5. After the required retention period (24 hours), the 24 hour residual chlorine sample shall be pulled, the heavily chlorinated water shall then be dechlorinated to 0 mg/L chlorine. A reducing agent shall be applied to the water before discharging, to neutralize thoroughly the chlorine residual remaining in the water. Two sets of Bac-T samples shall be taken, one immediately after the final flush, the second taken 24 hours later.
6. Contractor shall coordinate disinfectant testing and bacteriological testing to demonstrate that the above requirements have been met.

C. Slug Method

1. Water supplied from an approved source of supply shall be made to flow at a constant, measured rate into the new water main.
2. At a point not more than 10 ft downstream from the beginning of the new main, water entering the new main shall receive a dose of chlorine fed at a constant rate such that the water will have not less than 100 mg/L free chlorine. To ensure that this concentration is achieved, the chlorine concentration should be measured at regular intervals.
3. The chlorine shall be applied continuously and for a sufficient period to develop a solid column, or "slug" of chlorinated water that will, as it moves through the main, expose all interior surfaces to a concentration of approximately 100 mg/L for at least 3 hours
4. If at any time chlorine residual drops below 50 mg/L, the flow shall be stopped. Then the chlorination equipment shall be relocated at the head of the slug, and, as flow is resumed, chlorine shall be applied to restore the free chlorine in the slug to not less than 100 mg/L.
5. After the required retention period (at least 3 hours), the 3 hour residual chlorine sample shall be pulled, the heavily chlorinated water shall then be dechlorinated to 0 mg/L chlorine. A reducing agent shall be applied to the water before discharging, to neutralize thoroughly the chlorine residual remaining in the water. Two sets of Bac-T samples shall be taken, one immediately after the final flush, the second taken 24 hours later.

6. Contractor shall co-ordinate disinfectant testing and bacteriological testing to demonstrate that the above requirements have been met.

END OF SECTION

SECTION 02930

SEEDING

PART 1 GENERAL

1.1 Section Description

- A. This section provides for areas to be restored with seeding materials.

1.2 Section Includes

- A. Soil for Repairs
- B. Mulch
- C. Fertilizer and Herbicide
- D. Seed

1.3 Related Sections

- A. Section 01300 – Submittals
- B. Section 01600 – Material and Equipment
- C. Section 01900 – Project Closeout
- D. Section 02200 - Excavation and Trenching
- E. Section 02931 - Sodding

1.4 References

- A. FS O-F-241 - Fertilizers, Mixed, Commercial.

1.5 Definitions

- A. Seeding areas: All areas disturbed by construction operations including areas of cut and fill, trenching, temporary roads, and temporary staging or storage areas shall be seeded unless otherwise specified.
- B. Sequence of Work: Sequence shall be clearing, grading, fertilizing, tilling, seeding, covering and firming, and application of mulch. All seeded areas shall be mulched with grain straw or wood cellulose fiber, or covered with erosion control fabric.
- C. Weeds: Include Dandelion, Jimsonweed, Quackgrass, Horsetail, Morning Glory, Rush Grass, Mustard, Lambsquarter, Chickweed, Cress, Crabgrass, Canadian Thistle, Nutgrass, Poison Oak, Blackberry, Tansy Ragwort, Bermuda Grass, Johnson Grass, Poison Ivy, Nut Sedge, Nimble Will, Bindweed, Bent Grass, Wild Garlic, Perennial Sorrel, and Brome Grass.

1.6 Submittals

- A. Follow the procedures for submittals provided in Section 01300 - Submittals.
- B. Invoices and Analysis Labels: A copy of the supplier's invoices for all seed, mulch, and fertilizer which shows the quantity by weight purchased and a representative label bearing the manufacturer's or vendor's guaranteed statement of analysis shall be submitted to the CITY for review and approval to assure compliance with specified requirements for quality and application rates.

1.7 Quality Assurance

- A. Comply with regulatory agencies for fertilizer and herbicide composition.
- B. Seed and Fertilizer shall be labeled in accordance with U.S. Department of Agriculture Rules and Regulations under the Federal Seed Act and State seed laws. Seed shall be furnished in sealed standard containers of the vendor. Each seed container shall bear the name, trade name, or trade mark, and a warranty of the producer and a certificate of the percentage of the purity and germination of each kind of seed specified. Seed which has become wet, moldy, or otherwise damaged in transit or in storage will not be acceptable
- C. All seeding work shall be performed by a contractor having demonstrated experience in seeding on projects of similar size. The work shall be prepared by experienced personnel who are familiar with the required work and who are under the supervision of a qualified foreman at all times when the work is in progress.
- D. The Contractor shall have access to equipment such as a fertilizer spreader, farm tractor with tilling equipment, grass seed drill or cultipacker type seeder, mulch blower, or hydromulcher for application of mulch, and straight serrated disk for crimping mulch into the soil.

1.8 Delivery, Storage, and Handling

- A. Follow the provisions for the delivery, storage, protection and handling Product to and at site provided in Section 01600 - Material and Equipment.
- B. Deliver grass seed mixture in sealed containers. Seed in damaged packaging is not acceptable.
- C. Deliver fertilizer in waterproof bags showing weight, chemical analysis, and name of manufacturer.

PART 2 PRODUCTS

2.2 Soil for Repairs

- A. The soil used in any repair work shall be of a quality at least equal to that in areas adjacent to the area to be repaired. Soil shall be free from tree roots, clay balls,

stones, and other materials that hinder grading, planting, and maintenance operations and that is free from noxious and other objectionable weed seeds and toxic substances.

2.3 Mulch

A. Vegetative Type Mulch:

1. Vegetative Type Mulch shall be baled, dry, unweathered, no discoloration or mold damage.
2. A minimum of 50 percent of weight of the herbage making up the material shall be a minimum of 10 inches in length. Mulch material containing an excessive amount of weed and crop seeds will not be acceptable.

B. Wood Cellulose Fiber Mulch:

1. Prepared from virgin wood fibers containing no substance that might inhibit germination or growth of grass seed. Mulch shall be dyed an appropriate color to allow visual maintenance of its application and shall contain a tacking agent. The wood cellulose fibers shall be evenly dispersed and suspended when agitated in water. When sprayed uniformly on the surface of the soil, the fiber shall form a blotter-like ground cover that readily absorbs water and allows infiltration to the underlying soil. Weight specifications from suppliers, and for all applications, shall refer only to air dry weight of the fiber, at a standard equivalent of 10 percent nominal moisture content.
2. The mulch material shall be supplied in packages having a gross weight not in excess of 100 pounds and shall be marked by the manufacturer to show the air-dry weight. Suppliers shall certify that laboratory and field testing of their product has been conducted. Certificates shall be submitted in accordance with Section 01300 and that it meets all of the foregoing requirements pertaining to wood cellulose fiber mulch.

2.4 Fertilizer and Herbicide

A. Starter Fertilizer:

1. Fertilizer shall be pelleted or granulated and shall be an approved brand composed of a "Slow Release Nitrogen" fertilizer in the 1-2-1 range, such as 13-25-12 grade. Fertilizer shall be uniform in composition, free flowing and suitable for application with approved equipment.

B. Herbicide:

1. Pre-emergent herbicide shall be siduron (Tupersan). In areas where herbicide runoff may compromise water quality, herbicide should be Glyphosage, N-(phosphonomethyl) glycine in a form approved for aquatic applications.

2.5 Seed

A. Pure Live Seed:

- The following formula shall be used to determine the amount of commercial seed required to provide each kind of seed for the specified quantities of pure live seeds:

$$\text{Pounds of Commercial Seed Required} = \frac{10,000 \times \text{Pure Live Seeds (lbs. Per acre)}}{\text{Purity (percent)} \times \text{Germination (percent)}}$$

- Type "A" Seed: This seeding mixture will normally be used when seeding is required in areas of non-residential established lawns, shoulders and slopes in street right-of-way, and any other areas where a high-type seeding is deemed necessary. The seed mixture will be 100 percent Turf-Type Tall Fescue composed of an equal mix of three of four compatible species. The mixture shall not include any varieties of the slower growing Turf-Type Tall Fescue. The species shall be one of the following or equal as approved by the CITY:

Apache	Arid	Austin
Bonanza	Carefree	Chieftan
Cimmaron	Cochise	Falcon
Guardian	Houndog	Jaguar II
Maverick II	Mustang	Olympic
Phoenix	Rebel II	Rebel 3D
Safari	Shenandoah	Thoroughbred
Titan	Tribute	Vegas

The seed mixture shall also include 100 percent Annual Rye grass to provide a temporary grass stand. The seed mixture shall be sowed at a rate of 10 lbs. per 1000 square feet (436 lbs. per acre) of the Turf-Type Tall Fescue and 2 lbs. per 1000 square feet (87 lbs. per acre) of the Annual Rye.

- Type "B" Seed: This seeding mixture will normally be used to seed areas off street right of ways that are not maintained.

Kind of Seed	Minimum Pure Live Seed	Rate of Pure Live Seed (Lbs. per Acre)
Alta Fescue or Kentucky 31 Fescue (Festuca Elation Var. Arundinces)	75	90
Rye grass (Lolium Perenne or L. Multiflorum)	80	50
TOTAL		140

4. Type "C" Seed: This seeding mixture will normally be used in public parks, wildlife refuges, and any other areas where this seeding mixture is deemed necessary. The types of seeding mixtures for different habitats will be as follows:

Planting Habitat	Scientific Name	Common Name	Initial or Permanent Cover	Coverage
Wet Woodland	<i>Elymus virginicus</i> L.	Virginia Wild Rye	P	3 lbs./ac pls.
	<i>Cinna arundinacea</i> L.	Woodreed	P	100 plants/ac
	<i>Sporobolus heterolepis</i> A. Gray	Prairie Dropseed	I,P	3 lbs./ac pls.
	<i>Elymus canadensis</i> L.	Canada Wild Rye	P	3 lbs./ac pls.
	<i>Festuca octoflora</i>	Six-weeks Fescue	I	0.5 lbs./ac pls.
	<i>Triticum aestivum</i> L.	Winter Wheat	I	60 lbs./ac pls.

Planting Habitat	Scientific Name	Common Name	Initial or Permanent Cover	Coverage
Dry Woodland	<i>Elymus canadensis</i> L.	Canada Wild Rye	P	3 lbs./ac pls.
	<i>Elymus virginicus</i> L.	Virginia Wild Rye	P	3 lbs./ ac pls.
	<i>Sporobolus heterolepis</i> A. Gray	Prairie Dropseed	I,P	3 lbs./ac pls.
	<i>Triticum aestivum</i> L.	Winter Wheat	I	60 lbs./ac pls.

Planting Habitat	Scientific Name	Common Name	Initial or Permanent Cover	Coverage
Wet Open	<i>Elymus canadensis</i> L.	Virginia Wild Rye	P	3 lbs./ac pls.
	<i>Echinochloa muricata</i> Fern.	Rough Barnyard grass	I,P	2 lbs./ac pls.
	<i>Spartina pectinata</i>	Prairie Cordgrass	P	200 rhiz./ac
	<i>Leersia oryzoides</i>	Redtop Bentgrass	P	200 rhiz./ac
	<i>Triticum aestivum</i> L.	Winter Wheat	I	60 lbs./ac pls.

5. Adding Switchgrass (*Panicum virgatum* – 3 lbs./acre) to the wet open mix would be a good idea. Of the native grasses listed, it provides the greatest soil erosion control because of its extensive root system. It is also drought tolerant and a warm season grass while the others are primarily cool season.

PART 3 EXECUTION

3.6 Preparation of Subsoil

A. General:

1. The work shall not be started until substantially all earthwork has been completed in the area to be seeded. The topsoil spread and finish grading shall be completed immediately before the seeding work is started.

B. Clearing:

1. Prior to grading and tilling, vegetation that may interfere with operations shall be mowed, grubbed, and raked. The collected material shall be removed from the site. The surface shall be cleared of stumps, stones, cable, wire, and other materials that might hinder the work or subsequent maintenance.

C. Grading:

1. Establish and maintain grades, in a true and even condition. Eroded areas and areas having inadequate drainage, as indicated by ponding of water, shall be filled. Ruts, deep tracks, dead furrows, and ridges shall be eliminated.

D. Cleanup:

1. Within reasonable time after completion of the construction operations, the entire area shall be cleared of excess soil and waste material, including, but not limited to, stones, stumps, roots, brush, wire, grade stakes, and all objects that might be a hindrance to maintenance operations or affect the visual appearance of the site. All roads over which hauling operations have been conducted, regardless of the type of surfacing, shall be kept clean, and soil clods and debris left on the surface shall be removed. The wheels of vehicles shall be cleaned to avoid leaving soil upon the surface of roads, walks, and other surfaced areas.

3.7 Fertilizing

- A. Application of Fertilizer: Fertilizer as specified shall be applied within 24 hours prior to the tilling operation. The fertilizer shall be distributed over the entire area to be seeded at the rate of 200 pounds per acre, and incorporated into the soil to a depth of at least 4 inches by disking or harrowing methods. Fertilizing rate is equivalent to 2.3 pounds per 500 square feet.

3.8 Seeding

A. Preparation of Seed Bed:

1. After fertilizer has been applied, the areas to be seeded shall be tilled to a depth of at least 4 inches by disking, plowing, harrowing, or other accepted

methods until the soil is well pulverized and smoothed with a weighted spike-tooth harrow, railroad chains, or bridge timber float drag. When a chisel plow is used, the chisels shall be set not more than 10 inches apart and the areas shall be cross or double-tilled. All areas shall be left smooth for ease of mowing. All operations shall be done in a direction parallel to the contour lines on the slope and not uphill or downhill. Areas tilled shall be maintained until seeding and mulching is complete to insure a smooth area with no gullies or depressions.

B. Application of Seed:

1. Seeding equipment calibration tests shall be made in the presence of the CITY to determine the equipment setting required to apply the seed at the specified rates. Markers shall be used to ensure that no skips occur between successive passes of the seeder. If unplanted skips and areas are noted after germination and the growth of the grass, the unplanted areas shall be prepared again, fertilized, seeded, compacted, protected with herbicide (Section 3.4.A) and mulched (Section 3.4.B) as if none of those steps had previously taken place. The seed box shall be kept at least half full during seeding operations to ensure even distribution of seed over all the areas seeded. The types of acceptable seeding depending upon the area are as follows:
2. All seeding work shall be done between the dates of February 1 and April 15 for spring planting or August 15 and October 15 for fall planting. Sowing shall be accomplished by use of an approved mechanical seeder or drill (hand spreader can be used in small areas), making sure that successive seed strips overlap to provide uniform coverage. The mixtures shall be applied in a crossing pattern of two passes, each applying half of the seed required. Seed should be drilled to a depth of 1/2 inch. The sprigs (rhizomes) shall be broadcast evenly and uniformly on the soil surface.

C. Compaction:

1. Immediately following the completion of seeding operations, the entire area shall be compacted by means of a roller weighing at least 60 but not more than 90 pounds per linear foot of roller or any other method approved by the CITY.

3.9 Seed Protection

A. Application of Herbicide:

1. Following completion of seeding operations, pre-emergent herbicide as specified shall be applied to all seeded areas at the rate suggested by the manufacturer.

B. Mulching:

1. Mulching shall be done within 24 hours following the seeding operation except in the case of wood cellulose type mulch.

2. **Vegetative Type Mulch:** Straw mulch shall be spread uniformly in a continuous blanket at a depth of not less than 1-1/2 inches and not more than 2 inches loose measurement (approximately 1-1/2 to 2 tons per acre). Mulch shall be spread by hand or by a blower type mulch spreader. Blower type mulch spreaders shall be adjusted and operated in such a manner as to prevent excessive breakage of the mulch material. If this cannot be accomplished, the mulch shall be spread by hand. Care shall be exercised to ensure that all wire from baled hay is collected as it is removed from the bale. Mulching shall be started at the windward side of relatively flat areas, or at the upper part of a steep slope, and continued uniformly until the area is covered. The mulch shall not be bunched.
 - a. No mulch shall be spread unless it can be anchored on the same day.
3. **Anchoring Straw Mulch:** The straw mulch shall be anchored in the soil to a depth of 2 to 3 inches by a notched disk set straight or a mulch crimping machine. The machine shall be weighted and operated in such a manner to secure the mulch firmly in the ground to form a soil binding mulch and prevent loss or bunching of straw by wind. Two or more passes may be required to anchor the mulch to the satisfaction of the CITY.
4. **Application of Wood Cellulose Fiber:** Wood cellulose fiber mulch shall be applied with a hydromulcher at not less than 1000 pounds per acre. Precautionary measures shall be taken in preventing overspray on structures, paving, and plantings.

3.10 Maintenance

A. Watering:

1. Promptly after seeding and mulching, wet the seedbed thoroughly. Watering shall continue so as to keep all areas moist throughout the germination period.

B. Water Usage:

1. Water used in this work shall be furnished by the Contractor and shall be suitable for irrigation and free from ingredients harmful to plant life. All watering equipment required for the work shall be furnished by the Contractor. Water shall be taken from adjacent fire hydrants or public water lines only through hydrant connections permitted and issued by CITY. Written approval from the property owner shall be obtained prior to the use of suitable water from ponds or creeks. Water from private owners shall also be metered.

C. Maintenance of Area:

1. The Contractor shall be responsible for maintaining all seeded areas until acceptance by the CITY. If at any time before acceptance of the completed contract, any portion of the seeded surface becomes gullied or otherwise

damaged, or the seeding has been damaged or destroyed, the affected portion shall be cleared of stones, etc. and repaired to re-establish the specified condition prior to the acceptance of the work.

2. In established yards, shoulders and slopes in street right-of-way, and any other areas where a Type "A" seeding is necessary, all newly seeded grassed areas shall be kept in a healthy growing condition by watering, weeding, mowing, trimming, edging, etc., until completion and acceptance by CITY. The seeded areas shall be mowed with approved mowing equipment to a height of 3 inches whenever the average height of vegetation becomes 6 inches.
3. Turf grass of one-square foot or more that does not show definite growth and establishment shall be re-seeded in accordance with all requirements of this section including soil preparation and mulching. The Contractor shall continue the care and maintenance of all seeded areas as specified above until all work of this project has been satisfactorily completed and all deficiencies have been corrected at which time final inspection shall be made.
4. Areas Off of Street Right-of-Way (Type "B" Seed): All seeded areas shall be maintained until acceptance by the Engineer. Maintenance shall include repair of erosion damage, re-seeding, including all preparation requirements maintenance of mulch, and watering.

END OF SECTION

SECTION 02931

SODDING

PART 1 GENERAL

1.1 Section Description

- A. This section provides for areas to be restored with sodding materials.

1.2 Section Includes

- A. Sod
- B. Fertilizer

1.3 Related Sections

- A. Section 01300 – Submittals
- B. Section 01600 – Material and Equipment
- C. Section 01900 – Project Closeout
- D. Section 02200 - Excavation and Trenching
- E. Section 02930 - Seeding

1.4 References

- A. ASPA (American Sod Producers Association) - Guideline Specifications to Sodding.
- B. FS O-F-241 - Fertilizers, Mixed, Commercial.

1.5 Definitions

- A. Sodding areas: All established lawn areas that have been disturbed by construction operations including areas of cut and fill, trenching, temporary roads, and temporary staging or storage areas shall be sodded unless otherwise specified.
- B. Sequence of Work: Sequence shall be clearing, grading, fertilizing, tilling, and sodding.
- C. Weeds: Includes Dandelion, Jimsonweed, Quackgrass, Horsetail, Morning Glory, Rush Grass, Mustard, Lambsquarter, Chickweed, Cress, Crabgrass, Canadian Thistle, Nutgrass, Poison Oak, Blackberry, Tansy Ragwort, Bermuda Grass, Johnson Grass, Poison Ivy, Nut Sedge, Nimble Will, Bindweed, Bent Grass, Wild Garlic, Perennial Sorrel, and Brome Grass.

1.6 Submittals

- A. Follow the procedures for submittals provided in Section 01300 - Submittals.

1.7 Quality Assurance

- A. Comply with regulatory agencies for fertilizer and herbicide composition.
- B. All sodding work shall be performed by a contractor having demonstrated experience in sodding on projects of similar size. The work shall be prepared by experienced personnel who are familiar with the required work and who are under the supervision of a qualified foreman at all times when the work is in progress.
- C. Sod: Shall be a minimum age of 18 months, with root development that will support its own weight without tearing, when suspended vertically by holding the upper two corners.
- D. Submit sod certification for grass species and the location of sod source.
- E. Sod Producer: Shall be a company specializing in sod production and harvesting with minimum three years documented experience.

1.8 Delivery, Storage, and Handling

- A. Follow the provisions for the delivery, storage, protection and handling Products to and at site provided in Section 01600 - Material and Equipment.
- B. Deliver sod in rolls. Protect exposed roots from dehydration.
- C. Do not deliver more sod than can be laid within 24 hours. Sod harvested more than 48 hours prior to placement will be rejected and shall be removed immediately from the site.

PART 2 PRODUCTS

2.2 Sod

- A. General:
 - 1. The sod to be used as source material shall be a thick stand of Kentucky Blue Grass, Turf Type Tall Fescue, Bermuda Grass, Zoysia Grass or other grasses as required. The sod shall contain a growth of not more than 1 percent of other grasses and clovers, shall be free from all prohibited and noxious weeds.
 - 2. Broken pads and torn or uneven ends will not be acceptable. Standard size sections shall be strong enough to support their own weight and should retain their size and shape when suspended vertically from a firm grasp on the upper 10 percent of the section. Sod shall not be harvested or transplanted

with moisture content (excessively dry or wet) that will adversely affect its survival.

3. Sod shall be relatively free of thatch, up to 1/2 inch allowable (uncompressed). Sod shall be reasonably free of diseases, nematodes, and soil-borne insects. State nursery and/or plant materials laws require that all sod entering inter-state commerce be inspected and approved for sale. The same applies to sod being shipped intra-state. The inspections and approval must be made by the state agricultural department, office of the state entomologist.
4. Sod for golf courses and other areas as deemed necessary shall be of the Kentucky Blue Grass and Turf Type Tall Fescue Grass as specified above. Bermuda Grass and Zoysia Grass sod will not be acceptable for these areas.

B. Turf Type Tall Fescue Sod:

1. Composed of an equal mix of three or four compatible species of 100 percent Turf Type Tall Fescue. The mixture shall not include any varieties of the slower growing Turf Type Tall Fescue "Dwarf". The species shall be one of the following:

Apache	Arid	Austin
Bonanza	Carefree	Chieftan
Cimmaron	Cochise	Falcon
Guardian	Hounddog	Jaguar II
Maverick II	Mustang	Olympic
Phoenix	Rebel II	Rebel 3D
Safari	Shenandoah	Thoroughbred
Titan	Tribute	Vegas

C. Kentucky Blue Grass and Turf Type Tall Fescue Sod:

1. Cut in strips of uniform thickness, the range of acceptable thickness shall be 1 1/2 to 2 inches; each strip containing at least one square yard. Sod shall be cut in strips not less than 12 inches wide.

D. Bermuda Grass or Zoysia Grass Sod:

1. Cut into strips of uniform thickness, the range of acceptable thickness shall be 1 1/2 to 2 inches; each strip being not less than 12 inches wide and 24 inches long. Strips that crumble will not be acceptable.

2.3 Fertilizer

- A. Fertilizer shall be inorganic 12.12.12 or 13.13.13 grade, uniform in composition, free flowing and suitable for application with approved equipment, delivered to the site in convenient containers, each fully labeled, conforming to applicable state

fertilizer laws, bearing the name, trade name, or trade mark and warranty of the producer.

PART 3 EXECUTION

3.4 Preparation of Subsoil

A. General:

1. The work shall not be started until all earthwork has been completed. Backfills and fills shall be properly compacted, the topsoil shall be spread and finish grading shall be completed immediately before the sodding work is started.

B. Preparation of Area:

1. Preparation of areas to be sodded shall include filling, reshaping eroded areas, cleaning ditches and refinishing slopes to the established grade section.

C. Cleanup:

1. Within reasonable time after completion of the construction operations, the entire area shall be cleared of excess soil and waste material, including, but not limited to, stones, stumps, roots, brush, wire, grade stakes, and all objects that might be a hindrance to maintenance operations or affect the visual appearance of the site. All roads over which hauling operations have been conducted, regardless of the type of surfacing, shall be kept clean, and soil clods and debris left on the surface shall be removed. The wheels of vehicles shall be cleaned to avoid leaving soil upon the surface of roads, walks, and other surfaced areas.

D. Preparation of Sod Bed:

1. After fertilizer has been applied, the areas to be sodded shall be tilled to a depth of at least 2 inches by disking, plowing, harrowing, or other accepted methods until the soil is well pulverized and smoothed with a weighted spike-tooth harrow, railroad chains, or bridge timber float drag. When a chisel plow is used, the chisels shall be set not more than 10 inches apart and the areas shall be cross or double-tilled. All areas shall be left smooth for ease of mowing. All operations shall be done in a direction parallel to the contour lines on the slope and not uphill or downhill.

3.5 Fertilizing

- A. Before tilling operations, fertilizer shall be spread uniformly at the rate of 300 pounds per acre. Fertilizing rate is equivalent to 3.5 pounds per 500 square feet.

3.6 Laying Sod

A. Application of Sod:

1. Kentucky Blue Grass and Turf Type Fescue sod shall not be placed during a drought, or during the period from June 1 to September 1, unless authorized by the CITY, and shall not be placed on frozen ground. Bermuda and Zoysia sods shall only be placed during the period from May 1 to October 15. The CITY reserves the right to delay the sodding of all types of sod or to vary the permissible sodding seasons, due to weather, soil conditions, or for other causes.
2. Sod shall be moist when it is placed. Sod strips shall be laid along contour lines, commencing at the lowest point of the area and working upward. The transverse joints of sod strips shall be staggered and the sod carefully placed to produce tight joints. If necessary to walk excessively on newly laid sod, walking boards should be laid for this purpose. The sod shall be firm and watered immediately after it is placed. The "firming" shall be accomplished by application of a roller weighing not less than 60 nor more than 90 pounds per linear foot of roller or other approved method.

B. Anchoring Sod:

1. On 2:1 slopes, or steeper, the sod shall be anchored with 1/2 inch square by 8 inch long wooden pegs. The wooden pegs shall be driven into the ground 3 pegs to the square yard or other approved methods. Pegging shall be done immediately after sod is firmed.

3.7 Maintenance

A. Water Usage:

1. Water used in this work shall be furnished by the Contractor and will be suitable for irrigation and free from ingredients harmful to plant life. All watering equipment required for the work shall be furnished by the Contractor. Water shall be taken from adjacent fire hydrants or public water lines only through hydrant connections permitted and issued by CITY. Written approval from the property owner shall be obtained prior to the use of suitable water from ponds or creeks. Water from private owners shall also be metered.

B. Maintenance:

1. The Contractor shall be responsible for maintaining the installed grass sod until all areas are complete and accepted by the CITY. Grass areas in excess of one square foot that are dead or in poor condition regarding color and quality shall be replaced including all sodded preparation steps, and fertilized at the Contractor's expense prior to final acceptance.
2. The Contractor shall maintain the grass area for a minimum period of approximately 30 days or until the grass reaches a mowing height of 4

inches. The Contractor shall notify the City that the installed grass is ready to be mowed, and upon approval, the Contractor shall cut and “bag” grass clippings to a height of 2 1/2 inches. Completion of the mowing and replanting of all dead or dying grass by the Contractor shall be required prior to final acceptance.

END OF SECTION

SECTION 03001

CONCRETE

PART 1 GENERAL

1.1 Section Description

- A. This section provides for the materials and procedures utilized in cast-in-place concrete for thrust restraints for water main construction. Concrete for repair of pavement base, and curb or sidewalk replacement shall be in accordance with KCMO Public Works Department requirements and Section 02575 and the Missouri Department of Transportation (MoDOT) requirements for work within MoDOT right-of-way.

1.2 Section Includes

- A. Concrete Mixture
- B. Curing
- C. Form Work
- D. Reinforcement

1.3 Related Sections

- A. Section 01300 – Submittals
- B. Section 01600 – Material and Equipment
- C. Section 02200 - Excavation and Trenching
- D. Section 02575 - Pavement Restoration
- E. Section 02608 - Concrete Vaults and Covers
- F. Section 02669 - Thrust Restraints

1.4 References

- A. ACI 301 - Specifications for Structural Concrete Buildings
- B. ASTM C33 - Standard Specification for Concrete Aggregates.
- C. ASTM C94 - Standard Specification for Ready-Mixed Concrete.
- D. ASTM C150 - Standard Specification for Portland Cement.
- E. ASTM C171 - Standard Specification for Waterproof Paper for Curing Concrete.

- F. ASTM C260 - Standard Specification for Air-Entraining Admixtures for Concrete.
- G. ASTM C309 - Standard Specification for Liquid Membrane-Forming Compounds for Curing Concrete.
- H. ASTM C494 - Standard Specification for Chemical Admixtures for Concrete.
- I. ASTM C881 - Standard Specification for Epoxy-Resin-Base Bonding Systems for Concrete.
- J. ASTM C1315 - Standard Specification for Liquid Membrane-Forming Compounds Having Special Properties for Curing and Sealing Concrete.
- K. MCIB – Specifications for Concrete Work.

1.5 Submittals for Review

- A. Follow the procedures for submittals provided in Section 01300 - Submittals
- B. Submit proposed mix design of each class of concrete to CITY for review prior to commencement of work.

1.6 Quality Assurance

- A. Perform work in accordance with ACI 301.
- B. Tests: Testing firm will take cylinders and perform slump and air entrainment tests in accordance with ACI 301 and ASTM standards.

PART 2 PRODUCTS

2.1 Concrete Mixture

- A. Concrete Mixture:
 - 1. The concrete shall be MCIB WA530-1-4 as designated by the Mid-West Concrete Industry Board, Inc., Kansas City, Missouri.
- B. Cement:
 - 1. The cement shall be Portland Cement Type I unless high early strength is required in which instance Type III shall be used.
 - 2. All cement shall conform to the "Standard Specification for Portland Cement," ASTM C150.
- C. Aggregate:

1. All aggregates shall conform to the appropriate bulletins and specifications of the Mid-West Concrete Industry Board, Inc.
- D. Admixtures:
1. Air-entraining admixtures shall comply with ASTM C260 (AASHTO M154), current edition.
 2. Chemical admixtures shall comply with ASTM C494 (AASHTO M194), current edition.
 3. All Concrete shall include a water-reducing admixture and an air-entraining admixture.
- E. Water:
1. Water for mixing and curing concrete shall be clean and free from injurious amounts of sewage, oil, acid, alkali, salt, or organic matter. (Only potable water will be acceptable without testing.)
- F. Ready-Mix Concrete:
1. Ready-mixed concrete shall be used unless otherwise permitted by the CITY.
 2. Ready-mixed concrete shall be mixed and delivered in accordance with the requirements set forth in the "Standard Specifications for Ready-Mixed Concrete," ASTM C94.

2.2 Curing

- A. Cotton Mats: American Association of State Highway Officials (AASHTO) - "Standard Specifications for Cotton Mats for Curing Concrete Pavements," Designation M-73, current edition.
- B. Burlap: AASHTO - "Standard Specifications for Burlap Cloth Made from Jute or Kenaf," M-182, Class 2, 3, or 4, current edition.
- C. Waterproof Paper: ASTM – "Standard Specification for Waterproof Paper for Curing Concrete", Designation C-171, Current Edition.
- D. Liquid Membrane: ASTM – "Standard Specifications for Liquid Membrane Forming Compounds for Curing Concrete", Designation C-309, current edition.
- E. Membrane Curing Compounds: ASTM C1315 - "Standard Specifications for Liquid Membrane-Forming Compounds Having Special Properties for Curing and Sealing Concrete", current edition.
- F. Concrete Bonding Agent; ASTM C881 - Standard Specifications for Epoxy-Resin-Base Bonding Systems for Concrete", Type I and V, moisture insensitive, current edition.

- G. Polyethylene Sheeting: AASHTO – “Standard Specifications for White Polyethylene Sheeting (Film) for Curing Concrete”, Designation M-171, current edition.

2.3 Form Work

- A. Refer to Section 03100 - Concrete Formwork

2.4 Reinforcement

- A. Refer to Section 03200 - Concrete Reinforcement

PART 3 EXECUTION

3.1 Surface Preparation

A. General:

1. Concrete shall not be placed on muddy or frozen ground.
2. Dry sub-grade shall be wetted in advance of concrete placement.
3. All mud, freestanding water, loose dirt, and debris shall be removed prior to placement of concrete.

B. Surface Preparation of Existing Concrete:

1. Where new concrete is placed against existing concrete, the surface of the existing concrete shall be chipped to remove the existing surface to a depth that exposes a clean concrete surface. No oil, grease, or dirt stains shall be evident when the new concrete is poured.
2. Latency or soft layers of mortar shall be removed from the top or face of previously hardened concrete prior to placing additional concrete in contact with the existing surfaces.
3. If, in the opinion of the CITY, a structural bond is required between the old and new concrete, a concrete bonding agent shall be used.

C. Under-Water Conditions:

1. Prior to placing concrete, any water flow into excavation or forms shall be controlled or stabilized.
2. Tremies shall be used in all cases unless other methods are specified.
3. Tremies shall be equipped with watertight valves or caps at the lower end that shall be kept submerged in freshly placed concrete when placing concrete.

3.2 Formwork

A. Refer to Section 03100 – Concrete Formwork

3.3 Reinforcement

A. Refer to Section 03200 – Concrete Reinforcement

3.4 Placing Concrete

A. General:

1. Only those methods and arrangements of equipment shall be used which will reduce to a minimum any segregation of coarse aggregate from the concrete.
2. Every consideration shall be given to the proper placement of all concrete and the proper care of all concrete after placement.
3. Sufficient capacity of manpower and placing equipment shall be provided so that the work may be kept free from cold joints and other defects in the finished product.
4. Concrete shall be deposited into the forms or on the grade as nearly as practicable in its final position and in such manner that the concrete will completely fill the forms.
5. Vibration shall not be used to move concrete in a horizontal direction after initial placement.
6. Placement of concrete on a slope shall begin at the lower end of the slope and progress upward.
7. Concrete that has partially hardened or has been contaminated by foreign material shall not be deposited in the work but shall be discarded.
8. When inclined chutes beyond the mixer are permitted by the CITY, a baffle shall be provided at the bottom end so that concrete will drop vertically without segregation.
9. No water shall be added to the concrete for any reason at the job site that will result in exceeding the specified water-cement ratio.
10. Care shall be taken to fill the forms and to finish the concrete so that top surface is true to line and grade.
11. Care shall be taken to assure proper concrete coverage of reinforcing steel and mesh as designed.
12. Care shall be taken to maintain the proper location of all joint material, dowels, embedded items, etc., during concrete placement.
13. No mud or other foreign materials shall be tracked into the concrete during placement operations, and all contaminated concrete shall be removed.

B. Footings:

1. Footings shall have sound and stable earth sides or assembled forms.
2. Placement operations shall be performed in such a manner as to prevent loose earth falling into footing area during placement of concrete.

C. Walls And Thrust Restraints:

1. Collection hoppers shall be used wherever depth of wall or thrust restraints exceeds four (4) feet.
2. Concrete that might contact forms or reinforcing steel during placement shall be placed by the use of trunks or pipes whenever the drop exceeds six (6) feet for unexposed work, or three (3) feet for exposed work.
3. When trunks or pipe are used, they shall be located at horizontal spacing of not to exceed ten (10) feet.
4. Concrete for walls and thrust restraints shall be placed in horizontal layers not exceeding two (2) feet in depth.
5. Where concrete is to be placed for slabs monolithically with walls, beams, or columns which have a depth of four (4) feet or more, the placing of concrete for slab shall be delayed one (1) to three (3) hours after placing of concrete in lower portions to allow for subsidence.
6. Placing of concrete in slabs and thrust restraints shall be done in such manner as to prevent "cold joints," both horizontally and vertically.

D. Slabs:

1. Strike-off screens shall be set to proper grades for all concrete slab construction, and the tolerance for screens for smooth finish slabs shall not exceed one-eighth (1/8) inch, plus or minus, in a distance of seven (7) feet.
2. Strike-off shall be accomplished by use of a straight edge of adequate weight and length.
3. Vibrating screens or other approved strike-off methods shall be used when concrete slump is less than three (3) inches and slab thickness is more than four (4) inches.
4. Jitterbugs shall not be used.

E. Vibrating:

1. Mechanical internal vibrators shall be used whenever possible in all formed concrete work.

2. Vibrators shall be inserted at uniform spacing of twelve (12) inches to twenty (20) inches to assure thorough consolidation of all concrete.
3. Vibrators shall be inserted and withdrawn vertically to a depth, which will assure penetration into the previous lift with vibration periods of from five (5) to fifteen (15) seconds.
4. Form vibration and hand spading will be required at points inaccessible for thorough internal vibration.
5. During placement of concrete, stand-by vibrators shall be immediately available in the event of mechanical failure in the vibrators being used.

3.5 Concrete Curing

A. General:

1. Curing and protection shall consist of providing adequate measures to prevent the loss of moisture so hydration of the cement can continue. Special care shall be taken to provide proper curing for all concrete, including edges.
2. All regular concrete shall be cured for a period of not less than five (5) days, and concrete made with high early strength cement shall be cured not less than three (3) days unless otherwise directed or specified by the CITY.
3. Whenever placing of concrete is interrupted, the concrete already placed shall be kept continuously moist with damp mats or burlap until placing is resumed. Concrete shall not be directly sprayed with water prior to obtaining initial set.

B. Concrete In Forms:

1. Concrete adjacent to wood forms shall be cured either by keeping the forms continuously wet, beginning not later than eighteen (18) hours after placing has been completed, or by loosening the forms as directed or approved by the Engineer and applying water to the top portion and allowing the water to run down between the forms and the concrete.
2. When metal forms are used for vertical surfaces, the forms shall either be kept in contact with the concrete for the entire curing period, or the forms may be removed completely and one of the other acceptable curing methods used.
3. Concrete slabs shall be cured by either wet covering, steel materials, or membrane curing compounds.
4. Supporting forms under flat slabs will not be required to be kept moist.

C. Curing Methods:

1. One of the following methods of curing shall be used as soon as possible after the final finishing operations and when the concrete has set sufficiently so that it will not be damaged in the process.

2. Wet covering shall consist of either burlap, cotton mats, damp earth or sand, or ponded water. Coverings shall be kept moist for the duration of the curing period. Water shall be applied in a manner, which will not damage the concrete, and shall be free from impurities, which may damage or discolor the concrete.
3. The covering shall completely cover the concrete surfaces with sufficient material remaining at the sides for proper anchorage. Adjoining sheets shall be lapped six (6) inches or be sealed. All tears and holes shall be patched promptly with adhesive tape or other approved means. The covering shall be anchored continuously around the edges and at laps, and shall be weighted on the surface as required to prevent billowing by the wind. The covering material may be reused provided all holes and tears are properly repaired.
4. During hot weather, the membrane curing compound shall be a white pigmented compound when used on concrete exposed to sunlight and on all other concrete unless the CITY specifies a clear type with fugitive dye. Membrane curing compounds shall not be used where concrete is to be bonded to concrete. Where concrete is to be painted or covered with floor covering, or where concrete is to be bonded to other construction material, membrane curing compound shall be applied by spraying in such a manner as to provide a uniform, continuous, and water-impermeable film using not less than the amount recommended by the manufacturer. Compounds shall be stirred prior to and during use. If an even covering cannot be obtained by one coat, the compound shall be applied in two (2) coats with the direction of application of the second coat at right angles to that of the first coat. The membrane shall be protected from damage during the curing period, and any damage shall be repaired promptly.
5. Vertical faces of slabs on grade shall be cured by backfilling with moist earth or by use of one of the methods described herein.
6. If approved by CITY, a combination of various curing methods may be used providing the intermediate time of exposure to drying is less than one (1) hour. For example, concrete work may be initially cured for one (1) day with a wet covering followed by four (4) days curing with a sheet material or membrane curing compound.

3.6 Concrete Protection

A. General:

1. The provisions of this Section shall apply to all concrete work, which is done when the air temperature is below forty degrees Fahrenheit (40° F) or forecast to drop below that temperature within twenty-four (24) hours of the time concrete is to be placed.
2. Concrete Production: Adequate equipment for heating the concrete materials shall be provided. No ingredient that is frozen or contains ice shall be placed in the mixer.

- a. When air temperature is below 40° F, or forecast to fall below 40° F in the next 24 hours, concrete ingredients shall be heated.
 - b. Temperature of concrete at time of delivery shall be not less than 60° F nor greater than 80° F, and 70° F is preferred.
 - c. Heating shall be accomplished by heating either the aggregates or the mixing water or both. When the water temperature is above 165° F, the aggregate shall be premixed with the water for one (1) minute before cement and admixtures are added. Cement shall not be mixed with water or aggregates having temperature above 165° F.
 - d. The addition of calcium chloride WILL NOT be permitted.
3. Placing and Finishing: Concrete shall not be placed on or come in contact with frozen subgrade or forms and equipment containing ice or snow.
- a. Concrete, when placed, shall have a slump not to exceed four (4) inches for flat work or five (5) inches for walls and columns.
 - b. During placing and finishing, concrete shall be maintained at a temperature of 50° F or above but not more than 80° F.
 - c. Heating of enclosures for flat slab finishing shall be done by vented heating methods, and open-flame heating methods will not be permitted.
 - d. Troweling shall be delayed in order to avoid bringing an excess of fines to the surface.
 - e. During placing and finishing, the slabs shall be protected from wind to prevent loss of heat and rapid drying.
4. Protection: When freezing temperatures are forecast, suitable and adequate facilities shall be provided prior to beginning concrete placement for maintaining the ambient air temperature at the surface of the concrete or forms for the times and temperatures specified herein.
- a. Type I (normal) cement concrete - not less than 50°F for five (5) days or 70°F for three (3) days.
 - b. Type II (low heat of hydration/moderate sulfate resistant) cement concrete - not less than 50°F for fourteen (14) days.
 - c. Type III (high early strength) cement concrete - not less than 50°F for three (3) days or 70°F for two (2) days.
 - d. Protective measures shall be maintained for at least four (4) days beyond the period specified above.

- e. Sudden cooling (in excess of 20°F in any 24-hour period) of ambient air temperature at the surface of the concrete or forms shall not be permitted. During this period concrete shall not be allowed to drop to a temperature below 40°F.
- f. Newly finished flat work shall be covered and protected during cold weather for at least 14 days against exposure to rain, sleet, and ice.
- g. All methods for protecting concrete shall be subject to approval of the Director.
- h. Insulated forms may be used when approved by the CITY. Care shall be taken to keep the internal concrete temperature below 130°F and avoid sudden cooling at end of protection period.
- i. During the entire protection period adequate means shall be provided to prevent loss of moisture from the concrete surface.

B. Hot Weather Protection:

1. General: The provisions of this Section shall apply to all concrete work that is done when the air temperature is above 80°F or forecast to rise above that temperature within 24 hours of the time concrete is to be placed.
2. Concrete Production: Stockpiled aggregates shall be saturated and the surface kept moist by intermittent sprinkling or continuous fog spray.
 - a. Mixing water shall be kept cool by adequate protection of storage tanks and piping. Supply lines shall be shaded, insulated, or buried.
 - b. When necessary to produce and maintain concrete at an acceptable temperature, chopped or crushed ice shall be added directly to the mixer to the limit of 50% by weight of the total water required. Ice shall be added at a rate and in a manner that it will be completely melted during the mixing period. Chilled mixed water will also be acceptable.
 - c. The cement factor required by the design mix shall be increased as necessary to maintain the specified water-cement ratio whenever additional water is added to compensate for loss of slump during transportation, handling, and placing.
3. Placing and Finishing: Temperature of concrete when placed shall not exceed 85°F.
 - a. Forms, reinforcing, and subgrade surfaces shall be wet down immediately before concrete is placed. Wetting down of areas around the work to cool the air and increase humidity is recommended.

- b. Placing and finishing shall be done as quickly as possible. Adequate manpower and equipment shall be available to handle and place the concrete immediately after its mixing and delivery to the site.
 - c. Concrete shall be placed in layers in such manner as to insure bond and union with adjacent layers, thus avoiding cold joints.
4. Protection: In extremely hot weather or in very dry and/or windy weather, sunshades, wind breakers, fog nozzles, or a combination of such items will be required during flat slab finishing operations.
- a. If in the opinion of CITY proper protection is not being provided, CITY may order concrete operations to be suspended until adequate protective measures are provided.
 - b. Concrete shall be kept cool and moist during the specified curing period.
 - c. Top surface of slabs shall be cured as specified in Paragraph 6-" Curing and Protection." Initial curing media shall be applied within 20 minutes after the final finishing has been completed in each area.
 - d. When air temperature exceeds 90°F and as soon as practicable without damage to the surface finish, all exposed concrete shall be kept continuously moist by means of fog sprays, wet burlap, cotton mats, and other effective means. This water cooling shall be in addition to the initial sealing by the membrane curing compound.

END OF SECTION

SECTION 03100
CONCRETE FORMWORK

PART 1 GENERAL

1.1 Section Description

- A. This section provides for the materials and installation for cast-in-place concrete formwork for water main construction work.

1.2 Section Includes

- A. Forms
- B. Form work accessories

1.3 Related Sections

- A. Section 01300 – Submittals
- B. Section 01600 – Material and Equipment
- C. Section 03001 - Concrete
- D. Section 03200 - Concrete Reinforcement

1.4 References

- A. ACI 347 - Recommended Practice For Concrete Formwork.

1.5 Submittals

- A. Follow the procedures for submittals provided in Section 01300 - Submittals.
- B. Shop Drawings: Indicate pertinent dimensions, materials, bracing, and arrangement of joints and ties.

1.6 Quality Assurance

- A. Perform Work in accordance with ACI 347.

1.7 Delivery, Storage, and Handling

- A. Follow the provisions for the delivery, storage, protection and handling products to and at site provided in Section 01600 - Material and Equipment.
- B. Store off ground in ventilated and protected manner to prevent deterioration from moisture.

PART 2 PRODUCTS

2.1 FORMS

- A. Suitable and substantial forms shall be provided for all structural concrete and, where required, for plain concrete. All forms shall be constructed and maintained plumb and true to line, securely braced, tied, clamped and shored, and tight enough to prevent leakage of mortar.
- B. The deflection of the forms due to the weight of plastic concrete, placing equipment, and workmen shall be accurately figured and taken into account in the design of the forms so that finished concrete members will have surfaces, lines, planes, and elevations required within tolerances in accordance with ACI 117.
- C. Forms shall be constructed so that they can be removed without damage to the concrete.
- D. Forms for walls and thrust restraints shall be designed structurally for the rate of placement of concrete.

2.2 Formwork Accessories

- A. Forms shall be securely braced and tied with approved form ties that do not leave any parts within 3/4 inch of the surface of the concrete. Wire ties and wood spreaders will not be permitted.

PART 3 EXECUTION

3.1 Preparation

- A. Verify lines, levels and centers before proceeding with formwork.
- B. A coat of non-staining oil, lacquer, or other approved material shall be applied to protect form surface and to facilitate stripping. Coating shall be applied in strict accordance with the current directions of the manufacturer.
- C. Screens shall be constructed and located so as to produce continuous plane surfaces and shall be sturdy and designed so as to leave no undesirable parts permanently embedded in the concrete.
- D. Screens shall be set sufficiently in advance of placement of concrete to avoid interruption in the placing of concrete.
- E. All exterior surfaces of the forms shall be thoroughly cleaned with water or compressed air immediately prior to placing of concrete.
- F. All surfaces of forms that are to be reused shall be thoroughly cleaned and repaired prior to reuse.

3.2 Erection - Formwork

- A. Openings and chases of proper size shall be provided in the forms for piping, ductwork, etc., at the locations indicated or as otherwise approved.
- B. All approved embedded items shall be accurately located and securely fastened in place prior to placing of concrete.
- C. Control, contraction, expansion, and construction joints shall be provided at the locations indicated or specified.

3.3 Form Removal

- A. Forms shall be removed in such manner as to assure the complete safety of the structure. In no case shall supporting forms or shoring be removed until the concrete members have acquired sufficient strength to support their weight safely.

END OF SECTION

SECTION 03200
CONCRETE REINFORCEMENT

PART 1 GENERAL

1.1 Section Description

- A. This section provides for the materials and installation for cast-in-place concrete reinforcement for water main construction work.

1.2 Section Includes

- A. Reinforcing steel bars, wire fabric and accessories for cast-in-place concrete.

1.3 Related Sections

- A. Section 01300 – Submittals
- B. Section 01600 – Material and Equipment
- C. Section 03001 – Concrete
- D. Section 03100 – Concrete Formwork

1.4 References

- A. ASTM A615/A615M - Standard Specification for Deformed and Plain Billet Steel Bars for Concrete Reinforcement.
- B. ASTM A616/A616M - Standard Specification for Rail Steel Deformed and Plain Bars for Concrete Reinforcement.
- C. CRSI 63 - Recommended Practice For Placing Reinforcing Bars.
- D. CRSI 65 - Recommended Practice For Placing Bar Supports, Specifications and Nomenclature.

1.5 Submittals for Review

- A. Follow the procedures for submittals provided in Section 01300 - Submittals.
- B. Shop Drawings: Indicate reinforcement bar sizes, spacing, locations, and quantities of reinforcing steel and wire fabric; bending and cutting schedules; splicing and supporting and spacing devices.

1.6 Quality Assurance

- A. Perform work in accordance with CRSI 63, CRSI 65, and CRSI Manual of Standard Practice.

PART 2 PRODUCTS

2.1 Reinforcement

- A. Reinforcing steel bars shall conform to the requirements of the following Standards and Grades:

<u>ASTM STANDARD</u>	<u>Grade</u>
A 615 - Billet Steel	40 or 60
A 616 - Rail Steel	50 or 60
A 617 - Axle Steel	40 or 60

- B. Welded steel wire fabric shall conform to the requirement of ASTM A185.

PART 3 EXECUTION

3.1 Preparation

- B. Before being installed in the final position, all metal reinforcements shall be free of mud, clay, ice, grease, oil, loose rust and scale, and other coatings that would reduce or destroy the bond.

3.2 Placement

- A. Metal reinforcements shall be accurately formed and positioned to the required dimensions.
- B. Steel reinforcements shall be accurately positioned as required and shall be secured against displacement by using annealed wire ties or suitable clips at all intersections.
- C. The steel reinforcements shall be supported by metal supports, spacers, or hangers.
- D. The legs on the metal chair supports shall be plastic coated.
- E. The minimum center to center distance between parallel bars shall be not less than two and five-tenths (2.5) times the diameter of the bars so installed; but in no case shall the clear spacing between bars be less than one and five-tenths (1.5) times the maximum size of the course aggregate.

3.3 Protection

- A. Metal reinforcements (bars or mesh) shall be protected with concrete as stipulated in the following table. The concrete cover shall be measured from the edge of the bar or mesh to the face of the concrete.

<u>Condition of Service</u>	<u>Minimum Inches of Cover</u>
Placed against undisturbed earth	3 inches
Formed face exposed to earth or liquid	2 inches
Other formed surfaces	3/4 inches

END OF SECTION