



CITY PLAN COMMISSION STAFF REPORT

City of Kansas City, Missouri
City Planning & Development Department
www.kcmo.gov/cpc

November 20, 2024

Project Name
Indiana Commons at Staley Corners East

Docket # 1.1 & 1.2

Request
CD-CPC-2024-00142
Rezoning without Plan

CD-CPC-2024-00143
Non-Residential Development Plan

Applicant
Patricia Jensen
Rouse Frets White Goss Gentile Rhodes, PC

Owner
Ed Lewis
Indiana North Development, LLC

Location 8699 N. Indiana Ave.
Area About 2.5 Acres
Zoning R-1.5
Council District 1st
County Clay
School District North Kansas City

Surrounding Land Uses
North: Residential, zoned R-1.5
South: Commercial, zoned B2-2
East: Residential, zoned R-1.5
West: Undeveloped, zoned B2-2

Land Use Plan
The Gashland/Nashua Area Plan recommends mixed use neighborhood for the land use and the proposed plan complies with this recommendation.

Major Street Plan
NE Barry Road and N Indiana Avenue is identified on the City's Major Street Plan.

APPROVAL PROCESS



SUMMARY OF REQUEST + KEY POINTS

The applicant is seeking approval of a rezoning without plan from district R-1.5 (residential) to district B2-2 (commercial) and a major amendment to a previously approved development plan to allow for additional commercial uses.

PROJECT TIMELINE

The application for the subject request was filed on 9/27/2024. No scheduling deviations from 2024 Cycle 11.2 have occurred.

REQUIRED PUBLIC ENGAGEMENT

Public engagement as required by 88-505-12 does apply to this request. The applicant hosted a meeting on 11/7/2024. A summary of the meeting is attached to the staff report, see Attachment #3.

EXISTING CONDITIONS

The 2.5 acres proposed to be rezoned from R-1.5 to B2-2 is within the Staley Corners East Development and is currently undeveloped.

CONTROLLING + RELATED CASES

Ord. No. 200183 & Ord. No. 200182 – On March 26, 2020, Council approved a rezoning and preliminary development plan for the northeast and northwest corners of NE Barry Road and N Indiana Avenue (CD-CPC-2019-00023, CD-CPC-2019-00022, CD-CPC-2019-00025, CD-CPC-2019-00026). Ord. No. 200182 required that a signal being installed at NE Barry Road and N. Indiana.

Ord. No. 230320 – On May 4, 2023, Council amended Ordinance No. 200182, passed on March 5, 2020, by repealing Conditions 3, 4, 6 and 33 contained in Section B of the Ordinance, which required the developer to install a traffic signal at the intersection of N.E. Barry Road and N. Indiana Avenue, make other related intersection improvements, and install a southbound right turn lane to westbound Highway 152 on ramp prior to the issuance of a certificate of occupancy for Phase 1 of Staley Corners East; and amending Committee Substitute for Ordinance No. 200183, passed on March 26, 2020, by repealing Condition 4 contained in Section B of the Ordinance to remove the requirement for the construction of a second northbound left turn lane on N. Indiana Avenue at its intersection with N.E. Barry Road.

PROFESSIONAL STAFF RECOMMENDATION

Docket # Recommendation
2.1 APPROVAL
2.2 APPROVAL WITH CONDITIONS

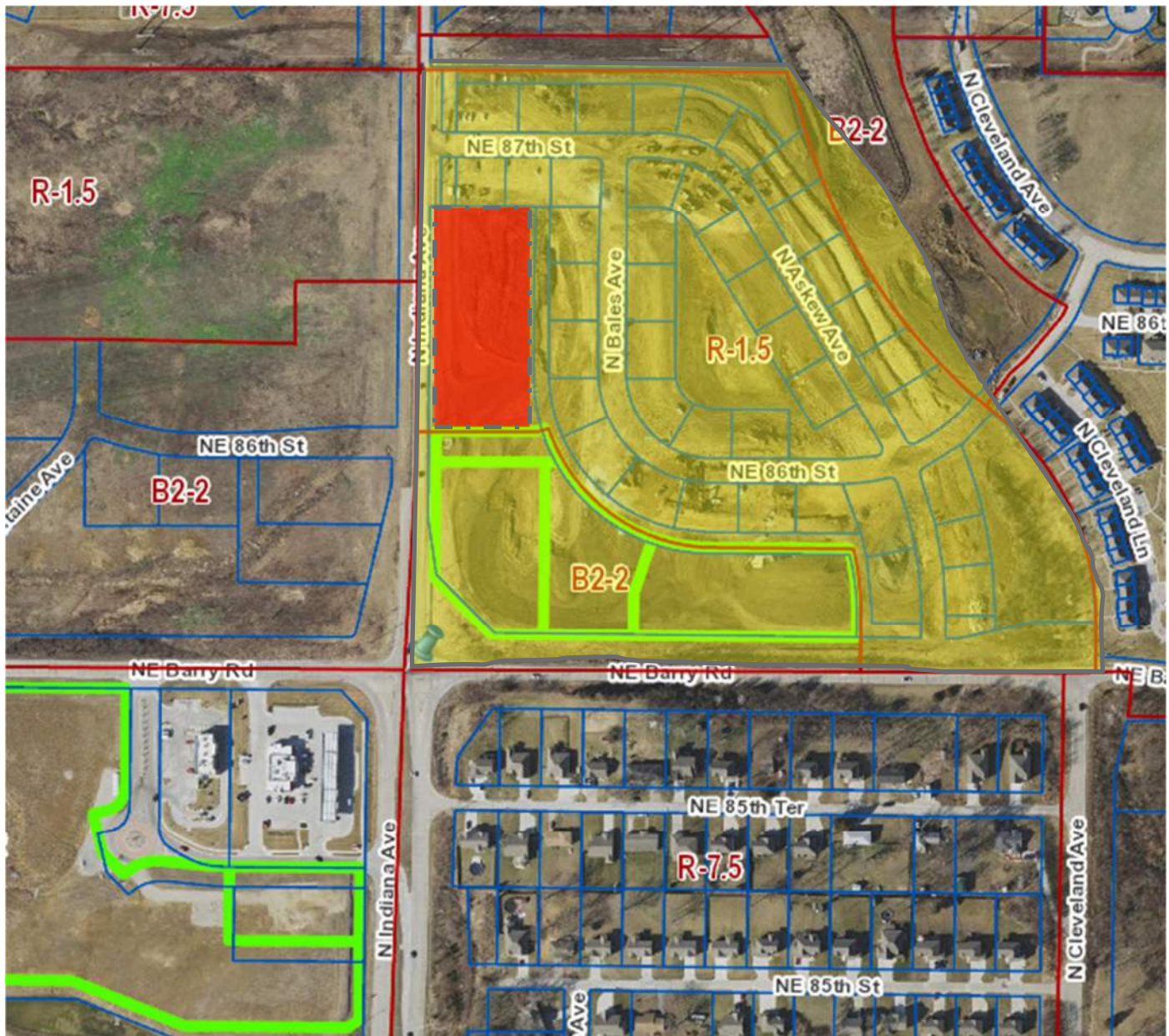
Vicinity Map**PLAN REVIEW**

The subject property is located within the boundaries of the Staley Corners East Development District which was approved by Council in March 2020. The approved development contains multiple rental units which have been recently constructed with more being built. The development will also feature a Casey's gas station on the far southwest corner (the project plan was approved by the City Plan Commission on July 17, 2024, CD-CPC-2024-00081). The applicant is proposing to rezone the area highlighted in red (above image) from R-1.5 to B2-2 to amend the previously approved use from a 40-unit senior residential building to allow for two, single story retail structures totaling nearly 20,000 square feet of floor space.

The original plan showed the senior housing adjacent to N. Indiana Avenue, screening the parking spaces from the public right-of-way. The applicant plans to construct 62 parking stalls adjacent to N. Indiana Avenue,

screened with a variety of ornamental trees, shrubs and grasses. Two pedestrian connections are proposed from both the southern and northern edges of the vehicular use area to the sidewalk along N. Indiana Avenue.

The original development plan approved in 2020 required the developer to install a traffic signal at NE Barry Road and N. Indiana Avenue prior to the issuance of any certificate of occupancy in Staley Corners East. In May 2023 the City Council passed Ordinance No. 230320 which repealed the requirement for the developer to install a traffic signal and multiple other related improvements within the public right-of-way. The City Engineer and the Public Works department are extremely concerned about the change in land use from senior housing to two commercial structures which will create additional vehicular congestion at the unimproved intersection of NE Barry Road and N. Indiana Avenue. The City Engineer has stated that there is currently no funding in the budget to construct the warranted traffic signal from the 2019 traffic impact study. Staff are recommending that the developer sign a Cooperative Agreement to help fund the warranted traffic signal. A temporary signal was installed at the intersection in July of 2024 and has improved vehicular circulation, but staff is concerned that the temporary signal will not be sufficient when the Casey's and other retail uses are constructed.

PLAN ANALYSIS

Staff worked with the applicant to enhance the proposed vehicular use area that will be visible from N. Indiana Avenue. There are currently multiple town homes being constructed immediately east of the proposed retail buildings and staff believe the two structures can serve as a buffer for future residents. The applicant also enhanced the architectural materials and overall design of the proposed structures to provide more four-sided architecture since the rear of the building will be visible from the residential units. There is an internal walking trail that runs along the rear (east side) of the proposed commercial structures which will be screened with additional landscaping to provide a more pleasant pedestrian experience.

As mentioned earlier, staff is concerned about an increase in vehicular traffic near the site due to the change from the original approved use (senior housing) to additional retail. Public Works and the City Engineer have asked that a signal be installed at NE Barry Road and N. Indiana Avenue prior to any building permit being issued for the proposed commercial structures.

The applicant is not seeking any new deviations, variances or relief from the Zoning and Development Code. The City Council granted relief (Ord. No. 200932) to allow for pavement in the front yard of the residential structures to exceed 40% of the total area within the front yard (88-420-03).

*indicates adjustment/deviation

Standards	Applicability	Meets	More Information
Lot and Building Standards (88-120)	Yes	Yes	
*Parking and Loading Standards (88-420)	Yes	Yes	Ord. No. 200932 permits residential driveways to exceed the 40% maximum impervious surface area in the front yard.
Landscape and Screening Standards (88-425)	Yes	Yes, subject to conditions	
Outdoor Lighting Standards (88-430)	Yes	Yes, subject to conditions	
Sign Standards (88-445)	Yes	Yes, subject to conditions	
Pedestrian Standards (88-450)	Yes	Yes	

SPECIFIC REVIEW CRITERIA**Zoning and Development Code Map Amendments, Rezoning (88-515-08)**

In reviewing and making decisions on proposed zoning map amendments, the City Planning and Development Director, City Plan Commission, and City Council must consider at least the following factors:

A. Conformance with adopted plans and planning policies;

The proposed rezoning and amendment to the previously approved development plan are in general conformance with adopted plans and planning policies. Public Works and City Planning are concerned about the potential safety of pedestrian and vehicular circulation at and near the intersection of NE Barry Road and N. Indiana until a proper traffic signal is installed.

B. Zoning and use of nearby property;

Staley Corners east is zoned B2-2 and R-1.5 with a mix of retail on the southern and southwestern perimeter and residential uses to the east. The proposed B2-2 is commonly found along commercial corridors.

C. Physical character of the area in which the subject property is located;

There is an existing QuikTrip on the southwest corner of NE Barry Road and N. Indiana with a Casey's soon to be constructed. There are low density residential neighborhoods within the general area of the subject property.

D. Whether public facilities (infrastructure) and services will be adequate to serve development allowed by the requested zoning map amendment;

There are adequate public facilities to serve the proposed development.

E. Suitability of the subject property for the use to which it has been restricted under the existing zoning regulations;

Staff support the previously approved plan which was zoned R-1.5 and proposed senior housing at this location. Staff believe that more senior housing would provide an opportunity for residents who live nearby to downsize but still be connected to their community.

F. Length of time the subject property has remained vacant as zoned;

Prior to 2019 this area was predominantly undeveloped with agricultural uses. The Staley Corners East development has seen multiple residential dwellings built over the last year and a half.

G. The extent to which approving the rezoning will detrimentally affect nearby properties; and

Without the construction of a traffic signal at the intersection of NE Barry Road and N. Indiana Avenue additional commercial uses could detrimentally impact the existing neighborhoods nearby.

H. The gain, if any, to the public health, safety, and welfare due to denial of the application, as compared to the hardship imposed upon the landowner, if any, as a result of denial of the application.

A denial of this application would only allow for senior housing on Lot 1 and Lot 2 instead of the proposed commercial buildings; a denial could encourage the developer to install a traffic signal at the intersection of NE Barry Road and N. Indiana Avenue to allow for more commercial development.

Development Plans, Project Plan, or Site Plan (88-516-05)

In order to be approved, a development plan, project plan, or site plan must comply with all of the following criteria:

A. The plan must comply with all standards of the Zoning and Development Code and all other applicable city ordinances and policies;

The proposed rezoning and amendment to the previously approved development plan are in general conformance with adopted plans and planning policies. Public Works and City Planning are concerned about the potential safety of pedestrian and vehicular circulation at and near the intersection of NE Barry Road and N. Indiana until a proper traffic signal is installed

B. The proposed use must be allowed in the district in which it is located;

If the proposed rezoning from R-1.5 to B2-2 is approved, then the two stand alone retail buildings will be allowed.

C. Vehicular ingress and egress to and from the site, and circulation within the site must provide for safe, efficient, and convenient movement of traffic not only within the site but on adjacent roadways;

The site plan provides efficient vehicular circulation within the Staley Corners East development. Staff are still concerned of the potential impact this development will have at the intersection of NE Barry Road and N. Indiana Avenue.

The City Engineer has stated that traffic backups and accidents have increased as a result of continued development. The City Engineer does not believe the traffic impact study does not adequately demonstrate the changes in traffic impacts on the existing conditions found at NE Barry Road and N.

Indiana Avenue.

D. The plan must provide for safe, efficient, and convenient non-motorized travel opportunities, being pedestrian and bicycle movement, on the subject site;

The applicant did coordinate with the Mobility Division in Public Works to design the pedestrian circulation in a way that provides safe, efficient and convenient movement, minimizing vehicular conflicts.

E. The plan must provide for adequate utilities based on City standards for the particular development proposed.

The subject property will be adequately served by utilities.

F. The location, orientation, and architectural features, including design and material, of buildings and other structures on the site must be designed to be compatible with adjacent properties.

The applicant is proposing two identical commercial structures that primarily consists of an EIFS façade, limestone veneer and cantilevered canopies throughout.

G. Landscaping, berms, fences, and/or walls must be provided to buffer the site from undesirable views, noises, lighting, or other off-site negative influences and to buffer adjacent properties from negative influences that may be created by the plan.

The applicant will provide a variety of plantings along N. Indiana Avenue and along the rear of the proposed buildings. The proposed landscape plan meets the minimum requirements per 88-425 of the Zoning and Development Code.

H. The design of streets, drives, and parking areas within the project should result in a minimum of area devoted to asphalt or other impervious surfaces consistent with the needs of the project and city code requirements.

Nearly the entire site will be impervious, and no green solutions are being incorporated into the proposed design.

I. The plan must identify trees to be removed and trees to be preserved during the development of the subject property with the goal of saving trees that are not required to be removed for the development of the property.

All trees were previously removed from the site.

ATTACHMENTS

1. Conditions Report
2. Applicants Submittal
3. Public Engagement Materials

PROFESSIONAL STAFF RECOMMENDATION

City staff recommend **APPROVAL** for the rezoning without plan (CD-CPC-2024-00142) and **APPROVAL WITH CONDITIONS** for the development plan (CD-CPC-2024-00143) as stated in the conditions report.

Respectfully Submitted,



Andrew Clarke, AICP
Lead Planner



Plan Conditions

Report Date: November 14, 2024

Case Number: CD-CPC-2024-00143

Project: Indiana Commons

Condition(s) by City Planning and Development Department. Contact Andrew Clarke at (816) 513-8821 / Andrew.Clarke@kcmo.org with questions.

1. The developer shall screen all roof and/or ground mounted mechanical and utility equipment in compliance with 88-425-08.
2. The developer shall submit an affidavit, completed by a landscape architect licensed in the State of Missouri, verifying that all landscaping required of the approved plan has been installed in accordance with the plan and is healthy prior to Certificate of Occupancy.
3. All signage shall conform to 88-445 and shall require a sign permit prior to installation.
4. The developer shall secure approval of a project plan from the City Plan Commission prior to building permit.
5. That prior to issuance of the Certificate of Occupancy for each lot within the plat the developer shall submit an affidavit, completed by a landscape architect licensed in the State of Missouri, verifying that street trees have been installed in accordance with the approved Street Tree Planting Plan and are healthy.
6. That Ordinance No. 200182, including all conditions provided therein, shall remain in full force and effect.
7. The developer shall submit an affidavit, prepared by an engineer licensed in the State of Missouri, verifying that all outdoor lighting has been installed in accordance with approved plans and that lighting levels do not exceed that shown on the approved lighting plan at the property lines prior to Certificate of Occupancy.
8. Prior to ordinance request the applicant shall enter into an agreement with the Director of Public Works to construct a signal at the intersection of NE Barry Road and N. Indiana Avenue.

Condition(s) by Fire Department. Contact Joseph Ragsdale at (816) 513-4643 / Joseph.Ragsdale@kcmo.org with questions.

9. Shall meet the minimum fire hydrant requirements of KCMO Water Services applicable to a water main extension which is every 300 feet commercial or 600 feet residentially zoned area.
10. The turning radius for fire department access roads shall be 30 feet inside and 50 feet outside radius. (IFC-2018: § 503.2.4)
11. Required fire department access roads shall be designed to support a fire apparatus with gross axle weight of 85,000 pounds. (IFC-2018: § 503.2.3)
12. Dead-end fire apparatus access roads in excess of 150 feet (45 720 mm) in length shall be provided with an approved area for turning around fire apparatus. (IFC-2018: § 503.2.5)
13. A required fire department access roads shall be an all weather surface. (IFC-2012: § 503.2.3) (No Grass Pavers Allowed)
14. Fire lane signage shall be provided on fire access drives. (IFC-2018 § 503.3)
15. Required fire department access roads shall be a minimum unobstructed width of twenty (20) feet and 13 ft. 6 in clearance height. Check with Streets & Traffic (KCMO Public Works) or Missouri Department of Transportation (MODOT) that may have street planning regulations that supersede the Fire Code. (IFC-2018: § 503.2.1)
16. Fire hydrants shall be installed and operable prior to the arrival of any combustible building materials onto the site. (IFC-2018 § 501.4 and 3312.1; NFPA 241-2013 § 8.7.2)
17. Fire Department access roads shall be provided prior to construction/demolition projects begin. (IFC-2018 § 501.4 and 3310.1; NFPA 241-2013 § 7.5.5)

Condition(s) by Fire Department. Contact Joseph Ragsdale at (816) 513-4643 / Joseph.Ragsdale@kcmo.org with questions.

18. Fire hydrant(s) shall be within 400 feet on a fire access road following an approved route established by the Authority Having Jurisdiction (AHJ) of any exterior portion of a building. The use of existing fire hydrant(s) may be used to satisfy this requirement otherwise a private fire hydrant(s) or hydrant system may be required. This distance may be increased to 600 feet for R-3 and U occupancy(s) or the building(s) is fully protected by an approved automatic fire sprinkler system(s). (IFC-2018: § 507.5.1)
19. Fire hydrant distribution shall follow IFC-2018 Table C102.1
20. The developer shall meet the fire flow requirements as set forth in Appendix B of the project International Fire Code 2018. (IFC-2018 § 507.1)

Condition(s) by Public Works Department. Contact Terry Thomas at (816) 513-2510 / Terry.A.Thomas@kcmo.org with questions.

21. The developer shall submit a letter to the Land Development Division from a Licensed Civil Engineer, Licensed Architect, or Licensed Landscape Architect, who is registered in the State of Missouri, that identifies sidewalks, curbs, and gutters in disrepair as defined by Public Works Department's "OUT OF REPAIR CRITERIA FOR SIDEWALK, DRIVEWAY AND CURB revised 11/5/2013" and based on compliance with Chapters 56 and 64 of the Code of Ordinances for the sidewalks, curbs, and gutters where said letter shall identify the quantity and location of sidewalks, curbs, gutters that need to be constructed, repaired, or reconstructed to remedy deficiencies and/or to remove existing approaches no longer needed by this project. The developer shall secure permits to repair or reconstruct the identified sidewalks, curbs, and gutters as necessary along all development street frontages as required by the Land Development Division and prior to issuance of any certificate of occupancy permits including temporary certificate occupancy permits.
22. The developer shall submit a streetscape plan for approval and permitting by the Land Development Division prior to beginning construction of the streetscape improvements in the public right of way, and construct ADA compliant ramps at all required locations where new private drives are being added, or where existing sidewalks are modified or repaired.
23. The developer shall submit verification of vertical and horizontal sight distance for the drive connection to public right-of-way to the Land Development Division and make improvements to ensure local jurisdiction and/or minimum AASHTO adequate sight distance standards are met, prior to issuance of any certificate of occupancy.
24. The developer shall pay impact fees as required by Chapter 39 of the City's Code of ordinances as required by the Land Development Division.
25. The developer shall dedicate additional right of way [and provide easements] for NE Barry Rd as required by the adopted [Major Street Plan and/or Chapter 88] so as to provide a minimum of 60 feet of right of way as measured from the centerline, along those areas being platted.

Condition(s) by Water Services Department. Contact Heather Massey at (816) 513-2111 / heather.massey@kcmo.org with questions.

26. The developer shall have a water flow test done to ensure there is adequate water pressure to serve the development.
South of River contact - Patrick Lewis 816-513-0423
North of River contact - David Gilyard 816-513-4772
27. The developer shall ensure that water and fire service lines should meet current Water Services Department Rules and Regulations. Prior to C of O.
<https://www.kcwater.us/wp-content/uploads/2022/05/2022-Rules-and-Regulations-for-Water-Service-Lines-Final.pdf>

Condition(s) by Water Services Department. Contact Kirk Rome at (816) 513-0368 / kirk.rome@kcmo.org with questions.

28. The existing public water main along the west property line is in an existing water easement and all grading within this easement shall be pre-approved by the KC Water Director. No tree planting shall be permitted within this water easement.

Condition(s) by Water Services Department. Contact Lucas Kaspar at (816) 513-2131 / Lucas.Kaspar@kcmo.org with questions.

29. The developer must secure permits to extend public sanitary and storm water conveyance systems to serve all proposed lots within the development and determine adequacy of receiving systems as required by KC Water, prior to recording the plat or issuance of a building permit whichever occurs first.
30. The developer must grant a BMP Easement to the City as required by KC Water, prior to recording the plat or issuance of any building permits.

Condition(s) by Water Services Department. Contact Lucas Kaspar at (816) 513-2131 / Lucas.Kaspar@kcmo.org with questions.

31. The developer shall submit an analysis to verify adequate capacity of the existing sewer system as required by KC Water prior to issuance of a building permit to connect private system to the public sewer main and depending on adequacy of the receiving system, make other improvements may be required.
32. The owner/developer must submit plans for grading, siltation, and erosion control to KC Water for review and acceptance, and secure a Site Disturbance permit for any proposed disturbance area equal to one acre or more prior to beginning any construction activities.
33. The developer must obtain the executed and recorded city approved grading, temporary construction, drainage/sewer, or any other necessary easements from the abutting property owner(s) that may be required prior to submitting any public improvements crossing properties not controlled by the developer and include said document(s) within the public improvement applications submitted for permitting.
34. The developer shall submit a detailed Micro storm drainage analysis from a Missouri-licensed civil engineer to KC Water showing compliance with the current, approved Macro study on file with the City and with current adopted standards in effect at the time of submission, including Water Quality BMP's, prior to approval and issuance of any building permits to construct improvements on the site or prior to recording the plat, whichever occurs first. The developer shall verify and/or improve downstream conveyance systems or address solutions for impacted properties due to flow contributions from the site; and that the developer construct any other improvements as required by KC Water as necessary to mitigate impacts from rate, volume, and quality of runoff from each proposed phase.
35. The developer shall cause the area to be platted and processed in accordance with Chapter 88, Code of Ordinances of the City of Kansas City, Missouri, as amended, commonly known as the Development Regulations.
36. The developer must enter into a covenant agreement for the maintenance of any storm water detention area tracts as required by KC Water, prior to recording the plat.

INDIANA COMMONS

INDIANA AVE & BARRY RD

CITY OF KANSAS CITY, CLAY COUNTY, MISSOURI

REZONING & DEVELOPMENT PLANS

AND PRELIMINARY PLAT



Know what's below.
Call before you dig.

Milburn Civil Engineering, LLC
 MILBURN CIVIL ENGINEERING, LLC
 33135 W 83RD ST
 DE SOTO, KS 66018
 913-583-0367



GENERAL NOTES:

1. PROPOSED CONTOURS, BMP's, GRADES, EASEMENTS, AND UTILITIES ARE INDICATED IN PLAN SET AND ARE SUBJECT TO FINAL ENGINEERING DESIGN AND APPROVAL BY DEVELOPMENT SERVICES, PRIVATE UTILITY COMPANIES AND FINAL PLAN APPROVAL. SEE GRADING, UTILITY, AND/OR STORM WATER MANAGEMENT PLAN.
2. FINAL PLANS FOR BUILDINGS WILL INCLUDE FINAL DETAILS ON BUILDING MATERIALS, BUILDING ELEVATIONS, AND SITE LIGHTING.
3. PARKING: WILL BE PROVIDED AS REQUIRED IN SECTION 88-420 OF THE KANSAS CITY ZONING AND DEVELOPMENT CODE.
4. LIGHTING: THE EXTERIOR LIGHTING IS TO BE DESIGNED TO COMPLY WITH KANSAS CITY ZONING AND DEVELOPMENT CODE SECTION 88-430.
5. STORM WATER DETENTION AND BMP's SHALL BE PER APPROVED STORM DRAINAGE STUDY OR PER DEPARTMENT OF PUBLIC WORKS. STORM WATER STUDY WILL IDENTIFY DETENTION, VOLUME CONTROL, AND TREATMENT AREAS. PROPOSED STORM WATER SYSTEM AND STORM WATER BMP'S ARE INDICATED ON STORM WATER, GRADING, AND UTILITY PLANS.
6. PARKLAND DEDICATION FEES SHALL FOLLOW KCMO ORDINANCE 88-408. REFER TO PARKLAND DEDICATION AND FEE CALCULATION TABLES IN PLAN SET.
7. BUILDING AND PARKING DIMENSIONS HAVE BEEN ROUNDED TO THE NEAREST FOOT.



INDEX OF SHEETS

C-0	COVER SHEET
C-1	SITE PLAN
C-2	GRADING PLAN
C-3	UTILITY PLAN
C-4	EXISTING CONDITIONS TREE PLAN/ TREE PRESERVATION & MITIGATION PLAN
C-5	PRELIMINARY PLAT
L1	LANDSCAPE PLAN
ES1.01	SITE LIGHTING PHOTOMETRICS
A200	EXTERIOR ELEVATIONS

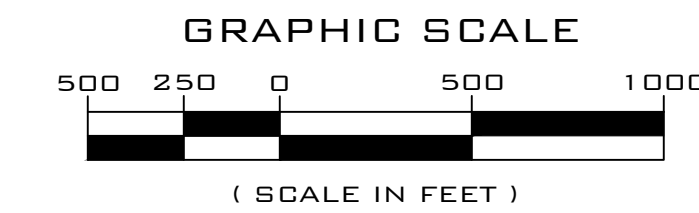
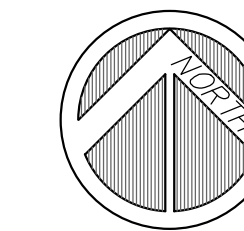

PREPARED BY:

MILBURN CIVIL ENGINEERING, LLC
 33135 W 83RD STREET
 DE SOTO, KS 66018
 913-583-0367
 MATTHEW RAVEILL, PE
 MATT@MILBURNCE.COM

OWNER/APPLICANT:

INDIANA NORTH DEVELOPMENT, LLC
 7067 NW SCENIC DR.
 PARKVILLE, MO 64152
 C/O ED LEWIS

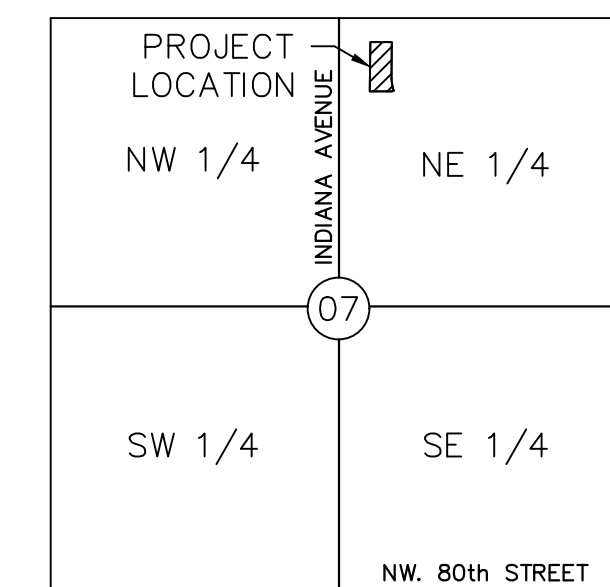

VICINITY MAP
 SEC. 07-51-32
 N.T.S.

INDIANA COMMONS
REZONING & DEVELOPMENT PLANS
AND PRELIMINARY PLAT
INDIANA AVENUE AND BARRY ROAD
KANSAS CITY, MO

DATE: 09/25/2024
 DESIGNED BY: LHP
 CHECKED BY: MJR

REVISIONS	REVISIONS
1-2024.10.31	KCMO COMMENTS

COVER SHEET

C-0

PRELIMINARY-NOT FOR CONSTRUCTION

Oct 31, 2024 - 3:53pm - USER: ipritchard
 F:\Chil_3D\Projects\Owens Built Properties\Staley Corners East 3rd Plat_2310-072\CAD\Sheets\Staley East 3rd - Development_Plan.dwg

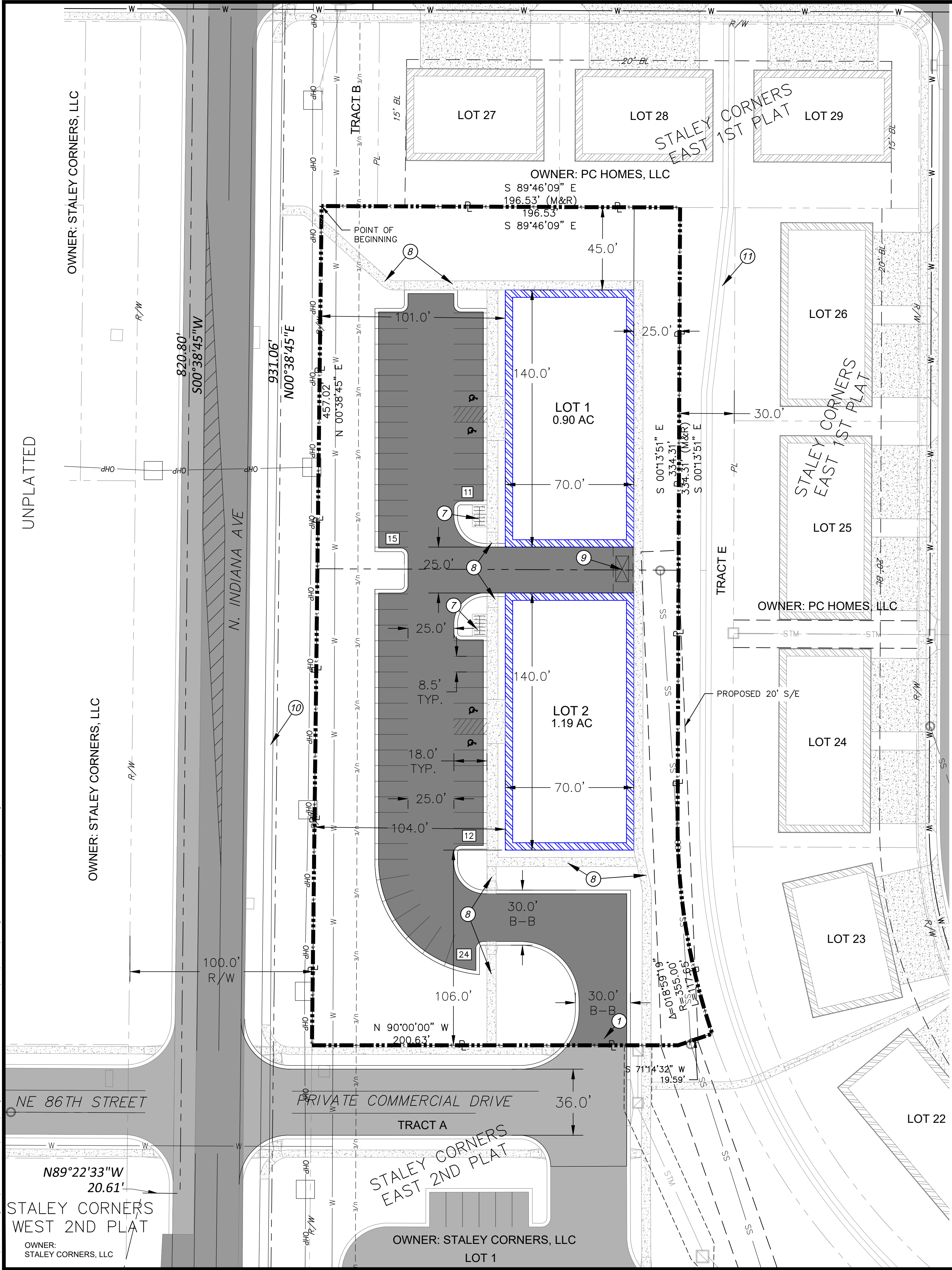

- DEVELOPMENT NOTES**
- ① PROPOSED PRIVATE ENTRY DRIVE
 - ⑦ PROPOSED BICYCLE PARKING
 - ⑧ PROPOSED SIDEWALK
 - ⑨ PROPOSED TRASH ENCLOSURE
 - ⑩ EXISTING SIDEWALK
 - ⑪ STALEY CORNERS EAST 1ST PLAT TRAIL

NOTE: ALL B2-2 USES ARE PERMITTED

- LEGEND**
- SS— PROPOSED SANITARY
 - SS— EXISTING SANITARY
 - W— PROPOSED WATER
 - W— EXISTING WATER
 - STM— PROPOSED STORM SEWER
 - RW— EXISTING RW
 - PL— PROPERTY LINE

LEGAL DESCRIPTIONS

A Tract of land in the Northeast Quarter of Section 7, Township 51 North, Range 32 West, in Kansas City, Clay County, Missouri being more particularly described as follows:
 Beginning at the Southwest Corner of Tract B, STALEY CORNERS EAST FIRST PLAT, a subdivision in Kansas City, Clay County Missouri, thence South 89°46'09" East along the South line of said Tract B and Lots 27 and 28, said STALEY CORNERS EAST FIRST PLAT, 196.53 feet to the Northwest Corner of Tract E, said STALEY CORNERS EAST FIRST PLAT;
 Thence South 00°13'51" West along the West line of said Tract E, 334.31 feet;
 Thence on a curve to the left, continuing along said West line, tangent to the last described course, having a radius of 355.00 feet and an arc length of 117.65 feet;
 Thence South 71°14'32" West, 19.59 feet;
 Thence North 90°00'00" West, 200.63 feet to the East Right-of-Way line of N Indiana Avenue, as now established;
 Thence North 00°38'45" East along said East Right-of-Way line, 457.02 feet to the Point of Beginning.
 Contains 91,292 square feet or 2.09 acres more or less.

Site Data	Existing	Proposed	Deviation Requested?	Approved
Zoning	R-1.5	B2-2		
Gross Land Area				
In square feet	91,292	91,292		
In acres	2.09	2.09		
Right-of-way Dedication				
In square feet	-	-		
In acres	-	-		
Net Land Area				
In square feet	-	-		
In acres	-	-		
Building Area (sq. ft.)	-	19,600		
Floor Area Ratio	-	0.22		
Residential Use Info				
Total Dwelling Units	-	-		
Detached House	-	-		
Zero lot line House	-	-		
Cottage House	-	-		
Semi-attached House	-	-		
Townhouse	-	-		
Two-Unit House	-	-		
Multi-Unit House	-	-		
Colonnade	-	-		
Multiplex	-	-		
Multi-unit Building	-	-		
Total Lots	-	2		
Residential	-	-		
Public/Civic	-	-		
Commercial	-	2		
Industrial	-	-		
Other	-	-		

Building Data	Required	Proposed	Deviation Requested?	Approved
Rear Setback	Abutting Residential: 25% of lot depth, Max = 30' Abutting Other: None	25'		
Front Setback	Abutting Residential: Match Residential setback Abutting Other: None	101'		
Side Setback	Abutting Residential: 10% of lot width, Max = 8' Abutting Other: None	23'		
Side Setback (abutting street)	Abutting Residential: 15' Abutting Other: None	106'		
Height	50' (Max.)	21'		
Square Feet per floor	25,000 (Max.)	9,800		
# of Floors	N/A	1		

88-420 Parking	Vehicles Spaces		Short-Term Bike Spaces		Long-Term Bike Spaces		Alternatives Proposed?
	Required	Proposed	Required	Proposed	Required	Proposed	
Retail (19,600 SF)	2.5 spaces / 1000 SF = 49 spaces required	62	10% of vehicles spaces, min. 3 = 6.2 spaces required	7	1 + 1 per 10,000 SF = 2.96 spaces required	3	3
Total		62		7		3	3

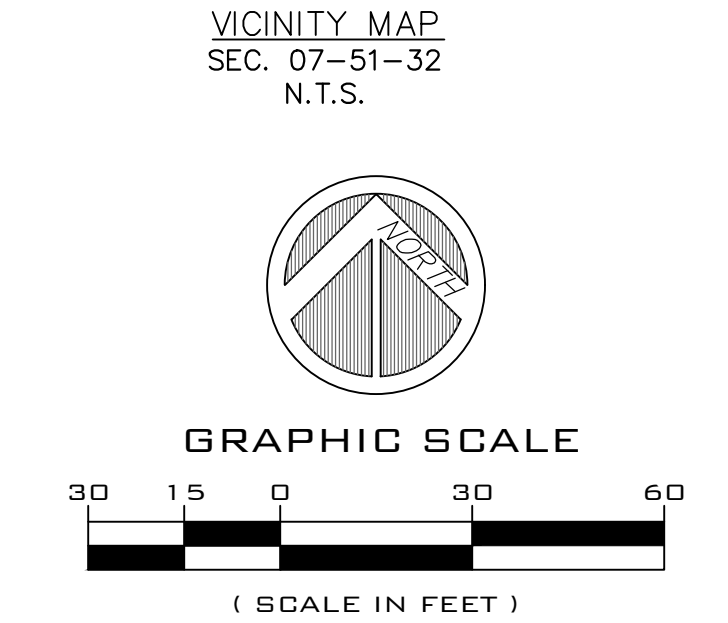
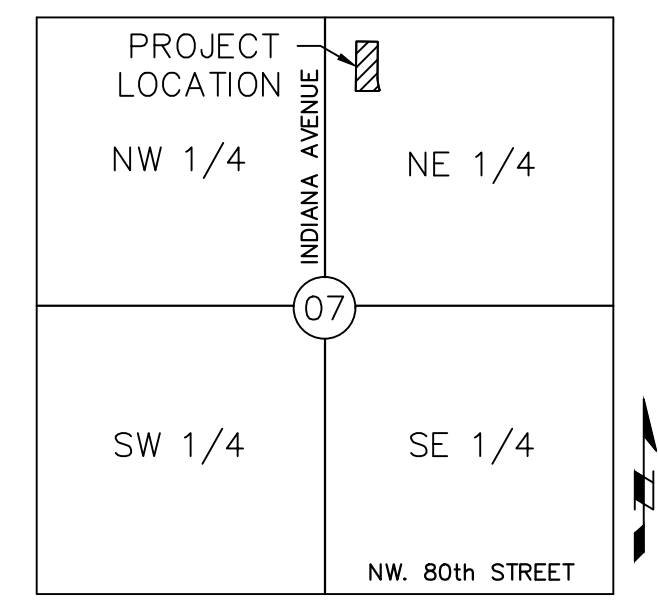

811
 Know what's below.
 Call before you dig.

Milburn Civil Engineering, LLC
 33135 W 83RD ST
 DE SOTO, KS 66018
 913-583-0367

STATE OF MISSOURI
 MATTHEW J. RAVELL
 PROFESSIONAL ENGINEER
 NUMBER PE-2012019478
 11/1/24

INDIANA COMMONS
 REZONING & DEVELOPMENT PLANS
 AND PRELIMINARY PLAT
 INDIANA AVENUE AND BARRY ROAD
 KANSAS CITY, MO

DATE: 09/25/2024
 DESIGNED BY: LHP
 CHECKED BY: MJR

REVISIONS: _____ REVISIONS: _____
 1-2024.10.31 KCMO COMMENTS

SITE PLAN

C-1

PRELIMINARY-NOT FOR CONSTRUCTION

Oct 31, 2024 - 3:54pm - USER: jpritchard
 F:\Chil_3D Projects\Owens Built Properties\Staley Corners East 3rd Plat_2310-072\CAD\Sheets\Staley East 3rd - Development Plan.dwg

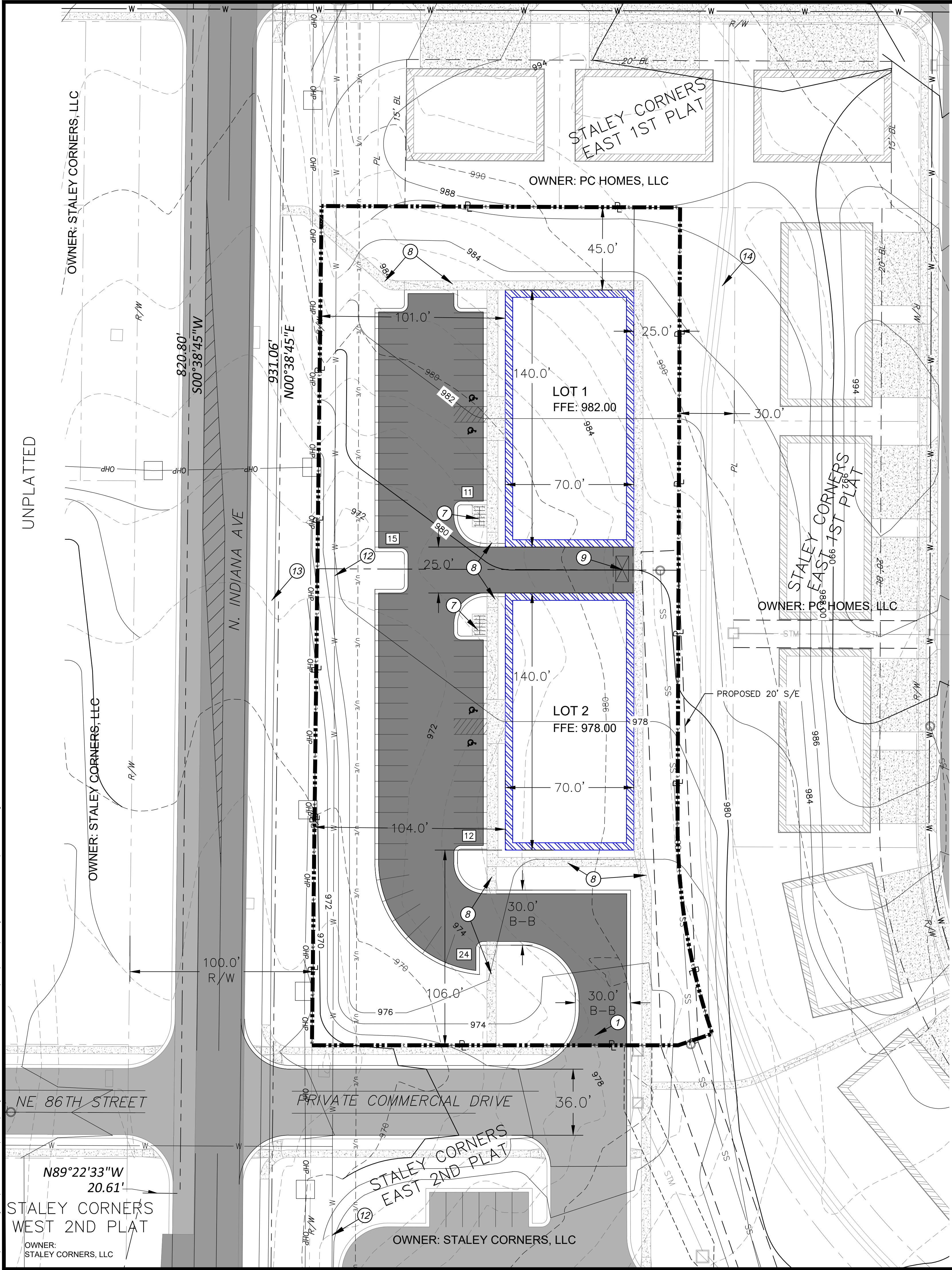

- DEVELOPMENT NOTES**
- ① PROPOSED PRIVATE ENTRY DRIVE
 - ⑦ PROPOSED BICYCLE PARKING
 - ⑧ PROPOSED SIDEWALK
 - ⑨ PROPOSED TRASH ENCLOSURE
 - ⑫ EXISTING WATER MAIN LINE
 - ⑬ EXISTING SIDEWALK
 - ⑭ STALEY CORNERS EAST 1ST PLAT TRAIL

- LEGEND**
- SS — PROPOSED SANITARY
 - SS — EXISTING SANITARY
 - W — PROPOSED WATER
 - W — EXISTING WATER
 - STM — PROPOSED STORM SEWER
 - RW — EXISTING RW
 - PL — PROPERTY LINE

Building Data	Required	Proposed	Deviation Requested?	Approved
Rear Setback	Abutting Residential: 25% of lot depth, Max=30' Abutting Other: None	25'		
Front Setback	Abutting Residential: Match Residential setback Abutting Other: None	101'		
Side Setback	Abutting Residential: 10% of lot width, Max=8' Abutting Other: None	23'		
Side Setback (abutting street)	Abutting Residential: 15' Abutting Other: None	106'		
Height	50' (Max.)	21'		
Square Feet per floor	25,000 (Max.)	9,800		
# of Floors	N/A	1		





Milburn Civil Engineering, LLC
 MILBURN CIVIL ENGINEERING, LLC
 33135 W 83RD ST
 DE SOTO, KS 66018
 913-583-0367



INDIANA COMMONS
 REZONING & DEVELOPMENT PLANS
 AND PRELIMINARY PLAT
 INDIANA AVENUE AND BARRY ROAD
 KANSAS CITY, MO

DATE: 09/25/2024
 DESIGNED BY: LHP
 CHECKED BY: MJR

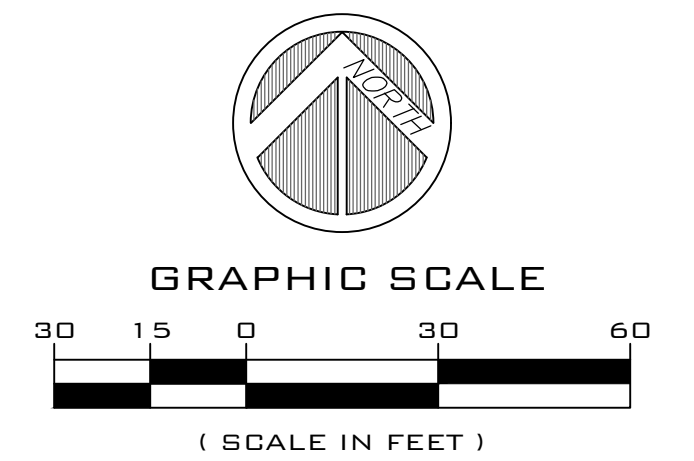
REVISIONS: _____ REVISIONS: _____
 1-2024.10.31 KCMO COMMENTS



GRADING PLAN

PRELIMINARY-NOT FOR CONSTRUCTION

Oct 31, 2024 - 3:54pm - USER: ipritchard
 F:\Chil_3D Projects\Owners Built Properties\Staley Corners East 3rd Plat_2310-072\CAD\Sheets\Staley East 3rd - Development Plan.dwg

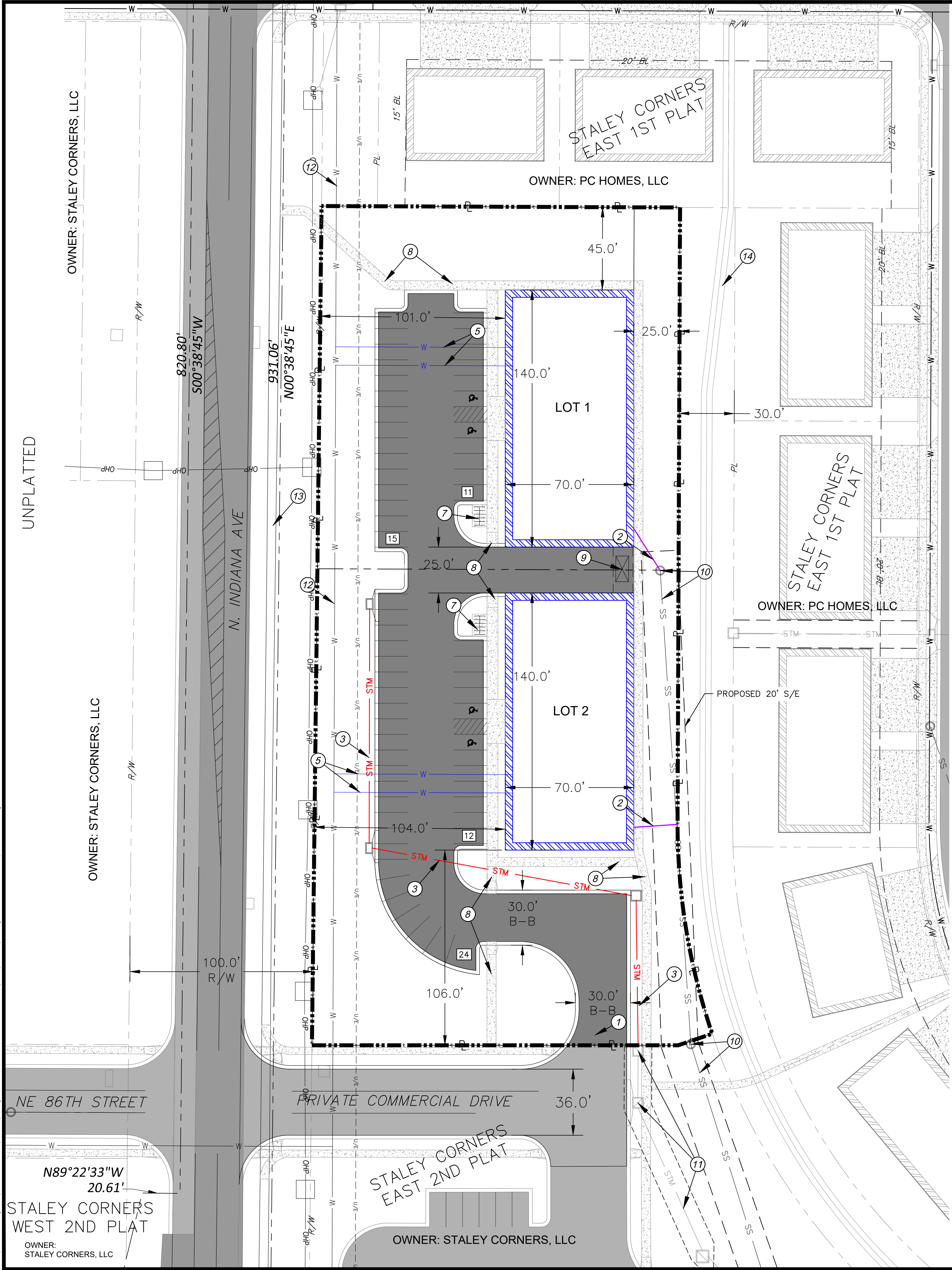

- DEVELOPMENT NOTES**
- ① PROPOSED PRIVATE ENTRY DRIVE
 - ② PROPOSED PRIVATE SANITARY SEWER
 - ③ PROPOSED PRIVATE STORM SEWER
 - ⑤ PROPOSED PRIVATE WATER SERVICE LINE
 - ⑦ PROPOSED BICYCLE PARKING
 - ⑧ PROPOSED SIDEWALK
 - ⑨ PROPOSED TRASH ENCLOSURE
 - ⑩ EXISTING SANITARY SEWER
 - ⑪ EXISTING STORM SEWER
 - ⑫ EXISTING WATER MAIN LINE
 - ⑬ EXISTING SIDEWALK
 - ⑭ STALEY CORNERS EAST 1ST PLAT TRAIL

- LEGEND**
- SS — PROPOSED SANITARY
 - SS — EXISTING SANITARY
 - W — PROPOSED WATER
 - W — EXISTING WATER
 - STM — PROPOSED STORM SEWER
 - RW — EXISTING RW
 - PL — PROPERTY LINE





Milburn Civil Engineering, LLC
 33135 W 83RD ST
 DE SOTO, KS 66018
 913-583-0367



INDIANA COMMONS
 REZONING & DEVELOPMENT PLANS
 AND PRELIMINARY PLAT
 INDIANA AVENUE AND BARRY ROAD
 KANSAS CITY, MO

DATE: 09/25/2024
 DESIGNED BY: LHP
 CHECKED BY: MJR

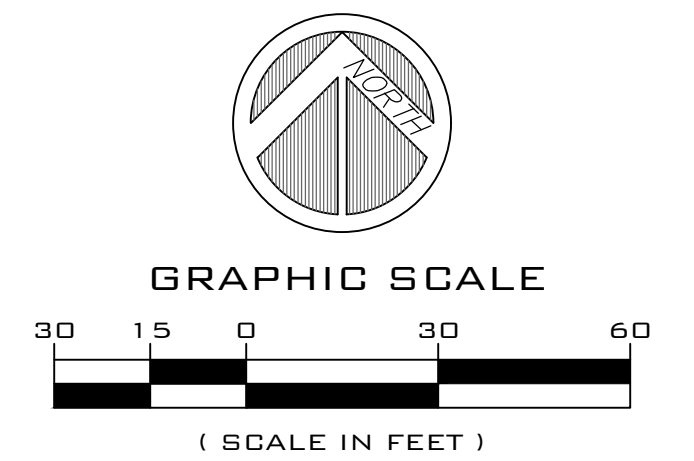
REVISIONS	REVISIONS
1-2024.10.31	KCMO COMMENTS



UTILITY PLAN

PRELIMINARY-NOT FOR CONSTRUCTION

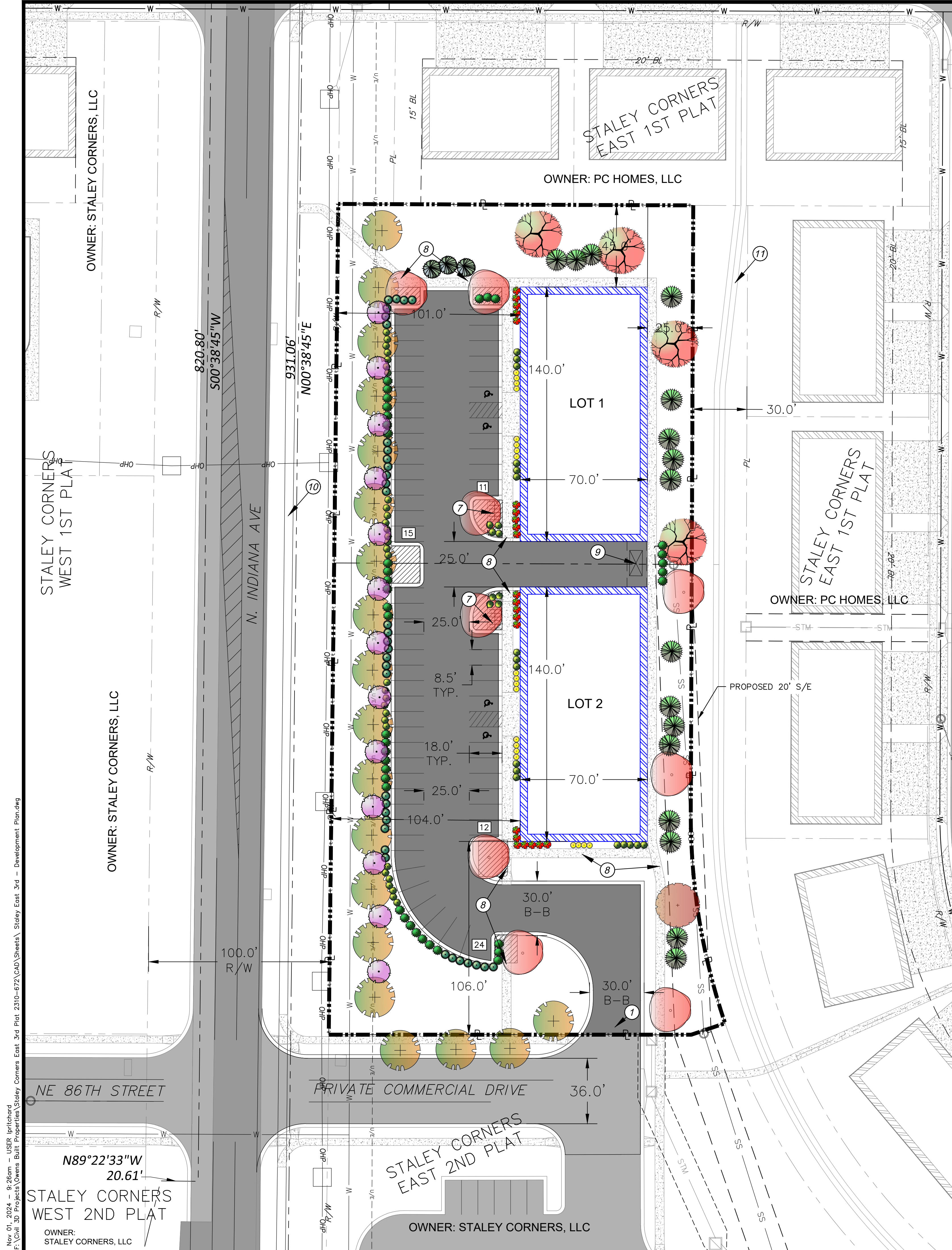

- DEVELOPMENT NOTES**
- ① PROPOSED PRIVATE ENTRY DRIVE
 - ⑦ PROPOSED BICYCLE PARKING
 - ⑧ PROPOSED SIDEWALK
 - ⑨ PROPOSED TRASH ENCLOSURE
 - ⑩ EXISTING SIDEWALK
 - ⑪ STALEY CORNERS EAST 1ST PLAT TRAIL

- LEGEND**
- PROPOSED SANITARY
 - SS— EXISTING SANITARY
 - W— PROPOSED WATER
 - W— EXISTING WATER
 - STM— PROPOSED STORM SEWER
 - RW— EXISTING RW
 - PL— PROPERTY LINE

NOTE:
NO MITIGATION SHALL BE REQUIRED IF CONTIGUOUS TREE CANOPY COVER IS LESS THAN ONE ACRE.

EXISTING TREE MITIGATION REQUIREMENTS:

TOTAL ACREAGE OF CONTIGUOUS CANOPY COVER TO BE REMOVED ON THE ENTIRE DEVELOPMENT SITE.
 SUBTRACT TOTAL ACREAGE OF ALL AREAS OF CONTIGUOUS TREE CANOPY COVER OF ONE ACRE OR MORE PRESERVED OUTSIDE OF ANY STREAM BUFFERS. 0 ACRES OF TREE COVER TO BE REMOVED.
 SUBTRACT STREAM BUFFER AREAS 0
 MULTIPLY ACREAGE CALCULATED BY .35: 0
 MULTIPLY THE ACREAGE CALCULATED BY 150 CALIPER INCHES: 0
 SUBTRACT TOTAL CALIPER INCHES OF TREES PROVIDED: 0
 0 TOTAL CALIPER INCHES REQUIRED FOR MITIGATION
 0 TOTAL CALIPER INCHES PROVIDED FOR MITIGATION
 NO MITIGATION REQUIRED.

Landscape Schedule

Symbol	Qty.	Botanical Name	Common Name	Min.Root	Min.Size	Caliper	Remarks
OVERSTORY TREES							
1	1	Nyssa sylvatica	Black Tupelo		2"	6' min. clear., ground to canopy	
4	4	Quercus rubra	Northern Red Oak		2"	6' min. clear., ground to canopy	
0	0	Platanus x acerifolia	London Plane Tree		2"	6' min. clear., ground to canopy	
20	20	Gleditsia triacanthos 'Shademaster'	Shademaster Honeylocust		2"	6' min. clear., ground to canopy	
11	11	Acer x truncatum 'Warrenred'	Pacific Sunset Maple		2"	6' min. clear., ground to canopy	
EVERGREEN TREES							
3	3	Juniperus chinensis 'Keteleeri'	Keteleeri Juniper		5' ht.		symmetrical pyramidal form
16	16	Juniper chinensis	Eastern Red Cedar		5' ht.		symmetrical pyramidal form
0	0	Picea abies	Norway Spruce		5' ht.		symmetrical pyramidal form
ORNAMENTAL TREES							
13	13	Cercis canadensis	Eastern Redbud			1.5"	
0	0	Cornus florida 'Cloud Nine'	Cloud 9 Dogwood			2"	
DECIDUOUS SHRUBS/GRASSES							
0	0	Liriope muscari 'Variegated'	Variegated Liriope		1 gal.		Plant @ 18" O.C.
20	20	Spiraea x bumalda 'Goldflame'	Goldflame spirea		3 gal.		Plant @ 3' O.C.
22	22	Hydrangea paniculata 'Quick Fire'	Little Quick Fire Hydrangea		3 gal.		Plant @ 4' O.C.
0	0	Syringa X 'Pendo'	Blooming Purple Lilac		5 gal.		Plant @ 5' O.C.
EVERGREEN SHRUBS							
38	38	Ilex glabra	Inkberry Holly		3 gal.		Plant @ 4' O.C.
55	55	Juniperus chinensis 'Gold Coast'	Gold Coast Juniper		3 gal.		Plant @ 4' O.C.
0	0	Juniperus chinensis 'Spartan'	Spartan Juniper		5' ht.		Symmetrical pyramidal form
35	35	Taxus x media 'Densiformis'	Dense Spreading Yew		3 gal.		Plant @ 4' O.C.
EXISTING TREES TO BE REMOVED				EXISTING TREES/SHRUBS TO BE PRESERVED			

Landscape Requirements/Calculations

88-425-LANDSCAPE SCHEDULE	Required	Proposed	Alt. Requested	Approved
88-425-03 Street Trees	30' o.c.	20	20	
88-425-04 General (15,000 sf bldg)	1 Tree/5000sf	4 Trees Provided		
88-425-05 Perimeter Vehicular Use Area				
Adjacent to streets				
Buffer Width	10' min.	Provided		
Trees	30' o.c.	Provided		
Shrub/Wall/Berm	Cont. Evergreen	Provided		
Adjacent to Residential Zones				
Buffer Width	10' min.	Provided		
Shrub/Wall/Berm	Shrubs	Provided		
88-425-06 Interior Vehicular Use Area (64 TOTAL PARKING STALLS)	35sf per Pkg Stall	2,240+ Provided		
Buffer Width	n/a			
Trees	1 Per 5 Stalls	13 Provided		
Shrubs	1 Per Stall	62 Provided		
88-425-07 Parking Garage Screening	n/a			
88-425-08 Mech./Utility Equip. Screening	Provided			
88-425-09 Outdoor Use Screening	n/a			



Milburn Civil Engineering, LLC
 33135 W 83RD ST
 DE SOTO, KS 66018
 913-583-0367



INDIANA COMMONS
 REZONING & DEVELOPMENT PLANS
 AND PRELIMINARY PLAT
 INDIANA AVENUE AND BARRY ROAD
 KANSAS CITY, MO

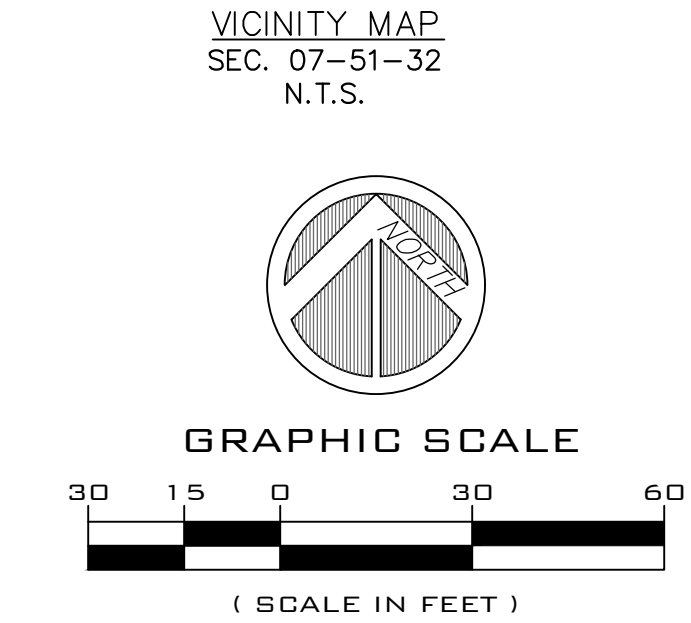
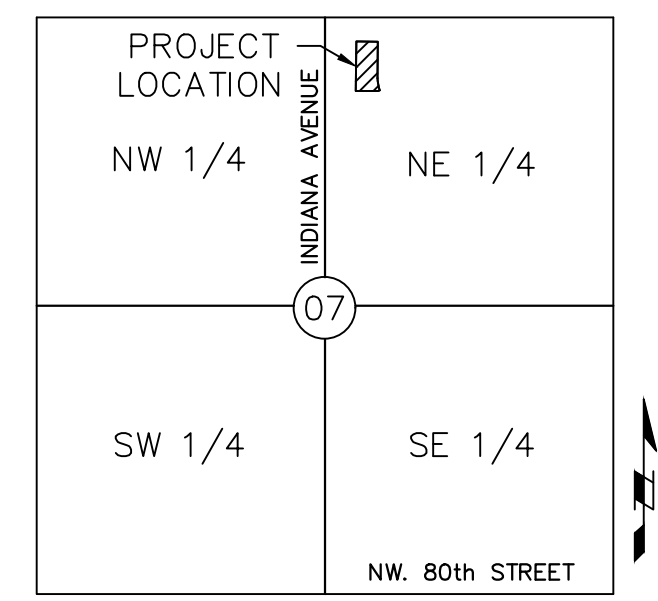

DATE: 09/25/2024
 DESIGNED BY: LHP
 CHECKED BY: MJR

REVISIONS: 1-2024.10.31 KCMO COMMENTS

EXISTING CONDITIONS
 TREE PLAN/
 TREE PRESERVATION
 & MITIGATION PLAN

Nov 01, 2024 - 9:26am - USER: iprtchard F:\Chil_3D Projects\Owens Built Properties\Staley Corners East_3rd Plat_2310-072\CAD\Sheets\Staley East_3rd - Development Planning

Nov 01, 2024 - 9:26am - USER: jprichard F:\Chil_3D Projects\Owens Built Properties\Staley Corners East 3rd Plat_2310-072\CAD\Sheets\Staley East 3rd - Development_Plan.dwg

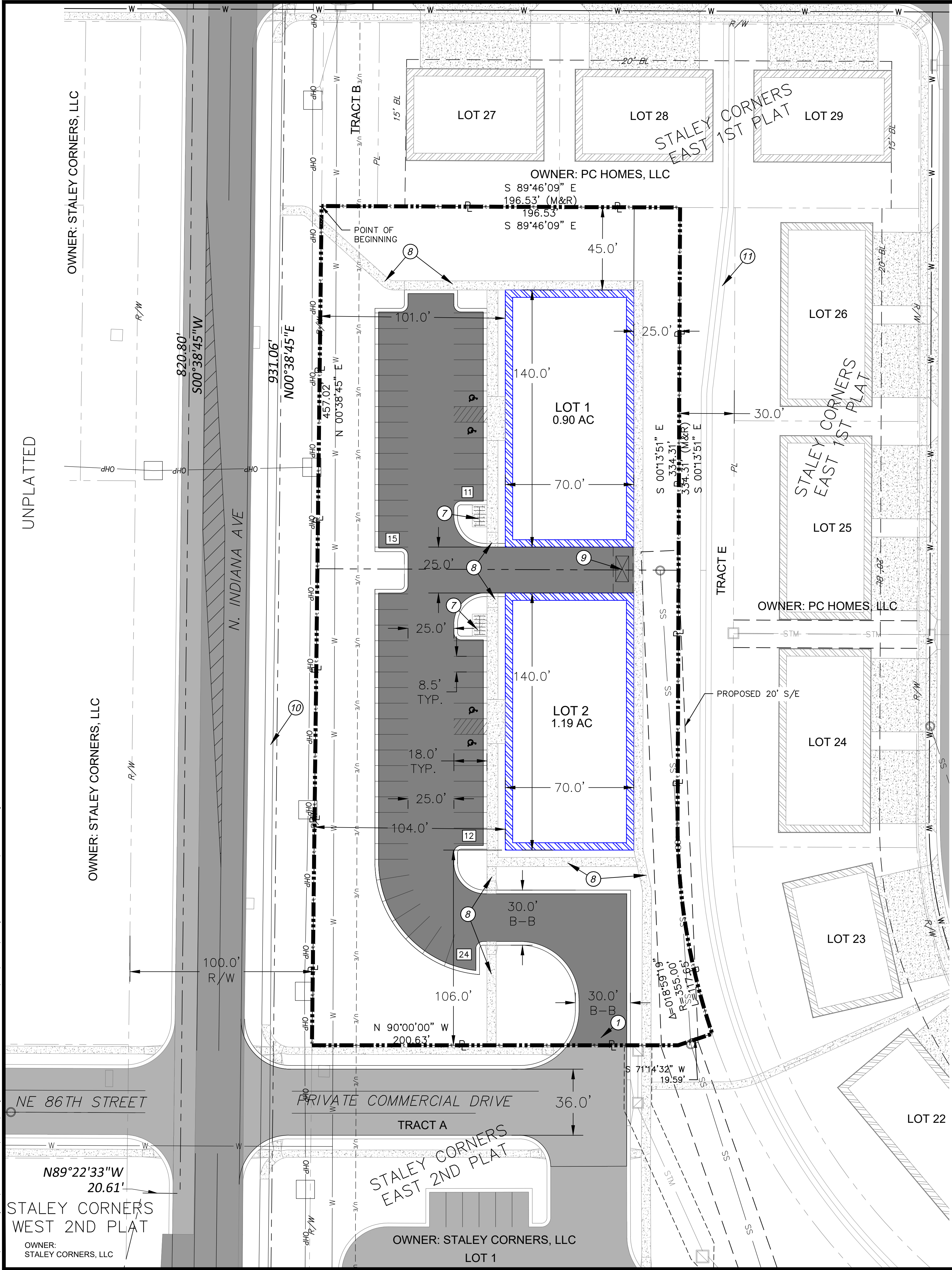

- DEVELOPMENT NOTES**
- ① PROPOSED PRIVATE ENTRY DRIVE
 - ⑦ PROPOSED BICYCLE PARKING
 - ⑧ PROPOSED SIDEWALK
 - ⑨ PROPOSED TRASH ENCLOSURE
 - ⑩ EXISTING SIDEWALK
 - ⑪ STALEY CORNERS EAST 1ST PLAT TRAIL

NOTE: ALL B2-2 USES ARE PERMITTED

- LEGEND**
- SS— PROPOSED SANITARY
 - SS— EXISTING SANITARY
 - W— PROPOSED WATER
 - W— EXISTING WATER
 - STM— PROPOSED STORM SEWER
 - RW— EXISTING RW
 - PL— PROPERTY LINE

LEGAL DESCRIPTIONS

A Tract of land in the Northeast Quarter of Section 7, Township 51 North, Range 32 West, in Kansas City, Clay County, Missouri being more particularly described as follows:
 Beginning at the Southwest Corner of Tract B, STALEY CORNERS EAST FIRST PLAT, a subdivision in Kansas City, Clay County Missouri, thence South 89°46'09" East along the South line of said Tract B and Lots 27 and 28, said STALEY CORNERS EAST FIRST PLAT, 196.53 feet to the Northwest Corner of Tract E, said STALEY CORNERS EAST FIRST PLAT;
 Thence South 00°13'51" West along the West line of said Tract E, 334.31 feet;
 Thence on a curve to the left, continuing along said West line, tangent to the last described course, having a radius of 355.00 feet and an arc length of 117.65 feet;
 Thence South 71°14'32" West, 19.59 feet;
 Thence North 90°00'00" West, 200.63 feet to the East Right-of-Way line of N Indiana Avenue, as now established;
 Thence North 00°38'45" East along said East Right-of-Way line, 457.02 feet to the Point of Beginning.
 Contains 91,292 square feet or 2.09 acres more or less.

Site Data	Existing	Proposed	Deviation Requested?	Approved
Zoning	R-1.5	B2-2		
Gross Land Area				
In square feet	91,292	91,292		
In acres	2.09	2.09		
Right-of-way Dedication				
In square feet	-	-		
In acres	-	-		
Net Land Area				
In square feet	-	-		
In acres	-	-		
Building Area (sq. ft.)	-	19,600		
Floor Area Ratio	-	0.22		
Residential Use Info				
Total Dwelling Units	-	-		
Detached House	-	-		
Zero lot line House	-	-		
Cottage House	-	-		
Semi-attached House	-	-		
Townhouse	-	-		
Two-Unit House	-	-		
Multi-Unit House	-	-		
Colonnade	-	-		
Multiplex	-	-		
Multi-unit Building	-	-		
Total Lots	-	2		
Residential	-	-		
Public/Civic	-	-		
Commercial	-	2		
Industrial	-	-		
Other	-	-		

Building Data	Required	Proposed	Deviation Requested?	Approved
Rear Setback	Abutting Residential: 25% of lot depth, Max = 30' Abutting Other: None	25'		
Front Setback	Abutting Residential: Match Residential setback Abutting Other: None	101'		
Side Setback	Abutting Residential: 10% of lot width, Max = 8' Abutting Other: None	23'		
Side Setback (abutting street)	Abutting Residential: 15' Abutting Other: None	106'		
Height	50' (Max.)	21'		
Square Feet per floor	25,000 (Max.)	9,800		
# of Floors	N/A	1		

88-420 Parking	Vehicles Spaces		Short-Term Bike Spaces		Long-Term Bike Spaces		Alternatives Proposed?
	Required	Proposed	Required	Proposed	Required	Proposed	
Retail (19,600 SF)	2.5 spaces / 1000 SF = 49 spaces required	62	10% of vehicles spaces, min. 3 = 6.2 spaces required	7	1 + 1 per 10,000 SF = 2.96 spaces required	3	
Total		62		7		3	

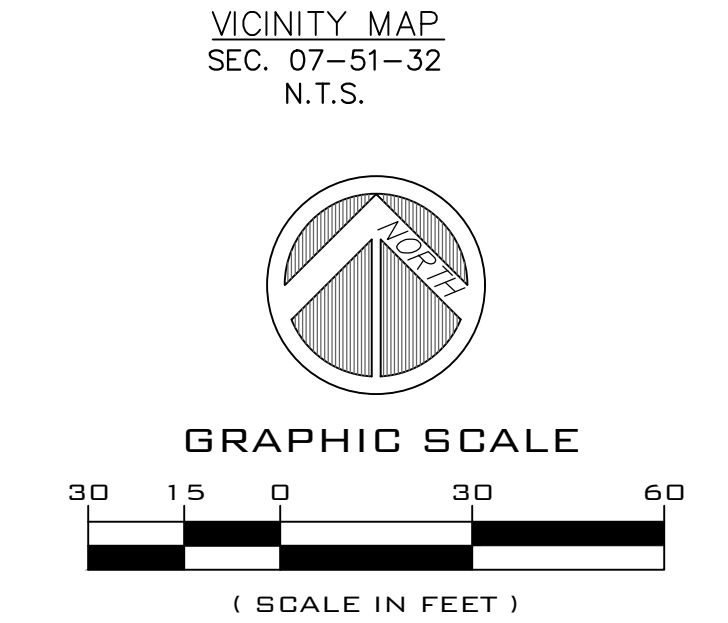
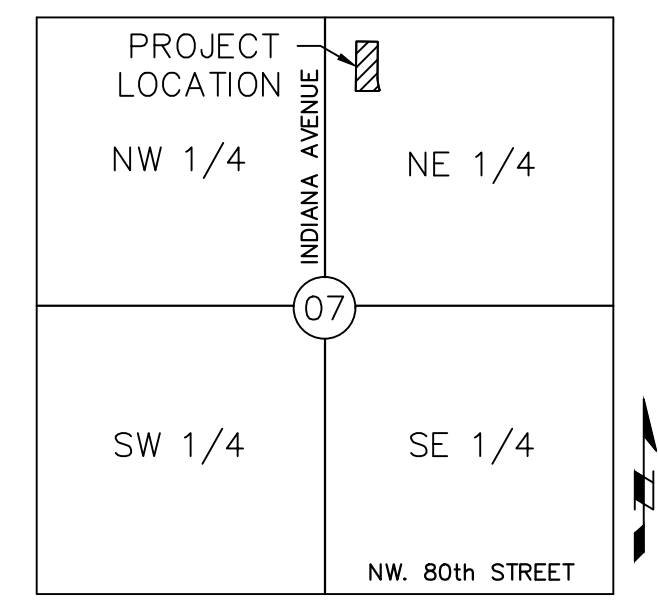

Milburn Civil Engineering, LLC
 33135 W 83RD ST
 DE SOTO, KS 66018
 913-583-0367

STATE OF MISSOURI
 MATTHEW J. RAVELL
 PROFESSIONAL ENGINEER
 NUMBER PE-20191478
 EXPIRES 11/14/24

INDIANA COMMONS
 REZONING & DEVELOPMENT PLANS
 AND PRELIMINARY PLAT
 INDIANA AVENUE AND BARRY ROAD
 KANSAS CITY, MO

DATE: 09/25/2024
 DESIGNED BY: LHP
 CHECKED BY: MJR

REVISIONS: 1-2024.10.31 KCMO COMMENTS

PRELIMINARY-NOT FOR CONSTRUCTION



CLIENT
 Indiana Commons

PROJECT
 Indiana Commons
 Barry Rd. and Indiana Ave.
 Kansas City, MO

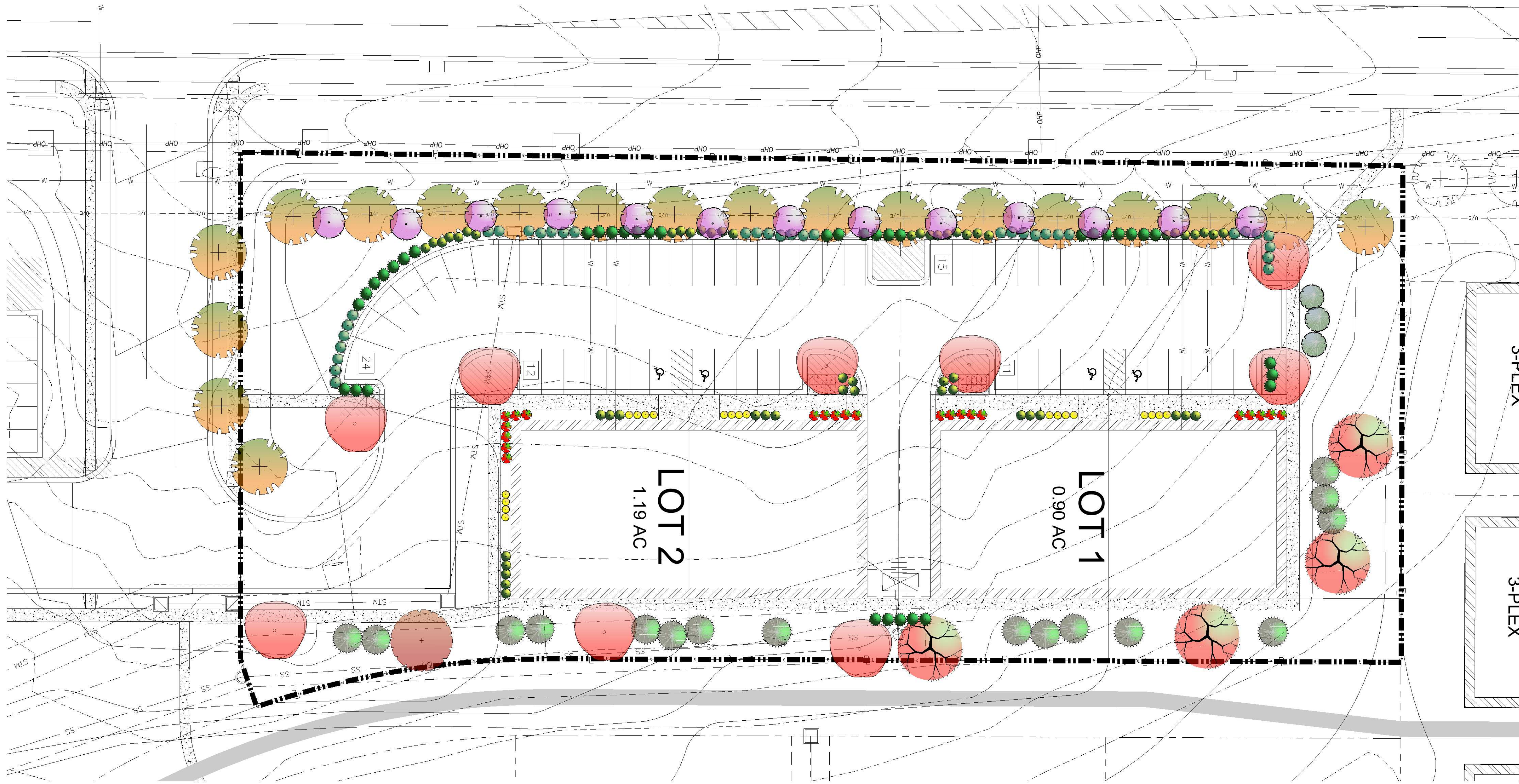

1 LANDSCAPE PLAN
 SCALE: 1"=20'-0"

- TREE PLANTING NOTES:**
- DO NOT HEAVILY PRUNE THE TREE. PRUNE ONLY CROSSOVER LIMBS, CO-DOMINANT LEADERS, & BROKEN OR DEAD BRANCHES. SOME INTERIOR TWIGS & LATERAL BRANCHES MAY BE PRUNED. DO NOT REMOVE THE TERMINAL BUDS OF BRANCHES THAT EXTEND TO THE EDGE OF THE CROWN
 - MARK THE NORTH SIDE OF THE TREE IN THE NURSERY, AND ROTATE TREE TO FACE NORTH AT THE SITE WHENEVER POSSIBLE
 - SET TOP OF ROOT BALL 12 INCHES HIGHER THAN SURROUNDING GRADE
 - APPLY 4" THK WOOD MULCH. DO NOT PLACE MULCH IN DIRECT CONTACT W/ TREE TRUNK
 - EACH TREE MUST BE PLANTED SUCH THE TRUNK FLARE IS VISIBLE AT THE TOP OF THE ROOT BALL. TREES WHERE THE FLARE IS NOT VISIBLE SHALL BE REJECTED. DO NOT COVER THE TOP OF THE ROOT BALL W/ SOIL
 - REMOVE ALL THINNE, ROPE, WIRE AND BURLAP FROM THE UPPER 1/3 OF ROOT BALL (REMOVE WIRE BASKETS)
 - PLACE ALL ROOT BALLS ON UN-EXCAVATED OR TAMPED SOIL, TYP

- STAKING REQUIREMENTS:**
- WIRE / CABLE SHALL BE GALV. 12-GAUGE
 - TIGHTEN WIRE / CABLE ONLY ENOUGH TO KEEP FROM SLIPPING. ALLOW FOR SOME TRUNK MOVEMENT. PLASTIC HOSE SHALL BE LONG ENOUGH TO ACCOMMODATE 1/2" OF GROWTH
 - STAKES SHALL BE 2" x 2" HARDWOOD OR EQUAL

- PERENNIAL PLANTING NOTES:**
- APPLY 2" THK BED OF MULCH ON PERENNIAL PLANT BED, DO NOT COVER PLANTS
 - THOROUGHLY MIX PEAT IN TOP 3-4" OF SOIL
 - BREAK UP EXISTING SOIL TO A DEPTH OF 24"
 - PROVIDE NEW TOPSOIL TO A DEPTH OF 12"

- SHRUB PLANTING NOTES:**
- SET SHRUB AT SAME DEPTH AT WHICH IT GREW IN THE FIELD OR CONTAINER
 - PRUNE, THIN & SHAPE SHRUBS IN ACCORDANCE W/ STANDARD HORTICULTURAL PRACTICE

- INITIAL WATERING:**
- WHEN BACKFILL IS 2/3 COMPLETE, WATER THOROUGHLY UNTIL NO MORE IS ABSORBED

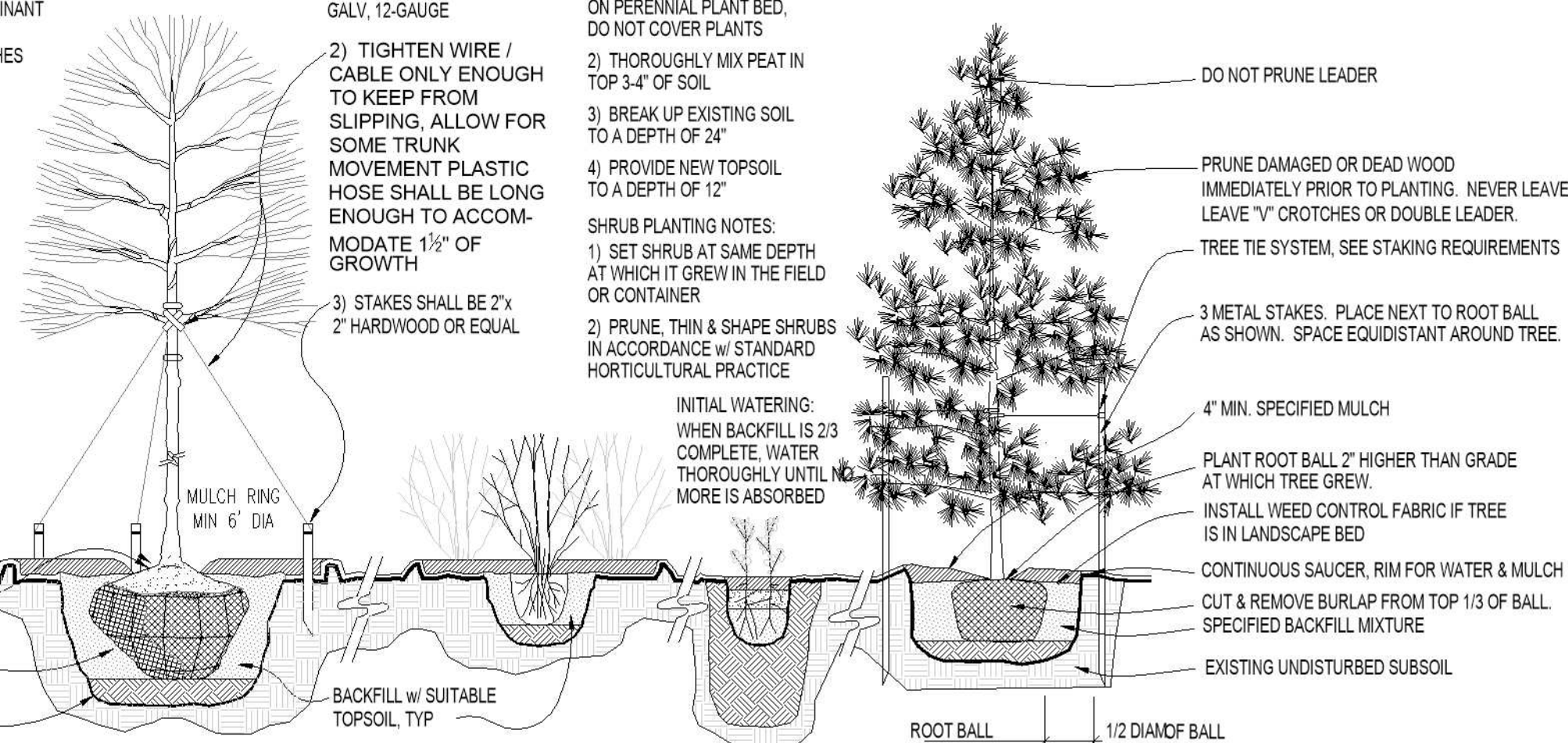

2 PLANTING INSTALLATION DETAILS
 SCALE: NTS

Landscape Requirements/Calculations

88-425-LANDSCAPE SCHEDULE	Required	Proposed	Alt. Requested	Approved
88-425-03 Street Trees 30' o.c.	20	20		
88-425-04 General (15,000 sf bldg)	1 Tree/ 5000sf	4 Trees Provided		
88-425-05 Perimeter Vehicular Use Area				
Adjacent to streets				
Buffer Width	10' min.	Provided		
Trees	30' o.c.	Provided		
Shrub/Wall/Berm	Cont. Evergreen	Provided		
Adjacent to Residential Zones				
Buffer Width	10' min.	Provided		
Shrub/Wall/Berm	Shrubs	Provided		
88-425-06 Interior Vehicular Use Area (64 TOTAL PARKING STALLS)				
Buffer Width	n/a			
Trees	1 Per 5 Stalls	13 Provided		
Shrubs	1 Per Stall	62 Provided		
88-425-07 Parking Garage Screening	n/a			
88-425-08 Mech./Utility Equip. Screening	Provided			
88-425-09 Outdoor Use Screening	n/a			

Landscape Schedule

Symbol	Qty.	Botanical Name	Common Name	Min. Root	Min. Size	Caliper	Remarks
OVERSTORY TREES							
[Symbol]	1	<i>Hyssa sylvatica</i>	Black Tupelo				2" 6' min. clear., ground to canopy
[Symbol]	4	<i>Quercus rubra</i>	Northern Red Oak				2" 6' min. clear., ground to canopy
[Symbol]	0	<i>Platanus x acerifolia</i>	London Plane Tree				2" 6' min. clear., ground to canopy
[Symbol]	20	<i>Gleditsia tricanthos</i> "Shademaster"	Shademaster Honeylocust				2" 6' min. clear., ground to canopy
[Symbol]	11	<i>Acer x truncatum</i> "Warrenred"	Pacific Sunset Maple				2" 6' min. clear., ground to canopy
EVERGREEN TREES							
[Symbol]	3	<i>Juniperus chinensis</i> "Keteleeri"	Keteleeri Juniper		5' ht.		symmetrical pyramidal form
[Symbol]	16	<i>Juniper chinensis</i>	Eastern Red Cedar		5' ht.		symmetrical pyramidal form
[Symbol]	0	<i>Picea abies</i>	Norway Spruce		5' ht.		symmetrical pyramidal form
ORNAMENTAL TREES							
[Symbol]	13	<i>Cercis canadensis</i>	Eastern Redbud		1.5"		
[Symbol]	0	<i>Cornus florida</i> "Cloud Nine"	Cloud 9 Dogwood		2"		
DECIDUOUS SHRUBS/GRASSES							
[Symbol]	0	<i>Liriope muscari</i> "Variegated"	Variegated Liriope	1 gal.			Plant @ 18" O.C.
[Symbol]	20	<i>Spiraea x bumalda</i> "Goldflame"	Goldflame spirea	3 gal.			Plant @ 3' O.C.
[Symbol]	22	<i>Hydrangea paniculata</i> "Quick Fire"	Little Quick Fire Hydrangea	3 gal.			Plant @ 4' O.C.
[Symbol]	0	<i>Syringa X 'Penda'</i>	Blooming Purple Lilac	5 gal.			Plant @ 5' O.C.
EVERGREEN SHRUBS							
[Symbol]	38	<i>Ilex glabra</i>	Inhberry Holly	3 gal.			Plant @ 4' O.C.
[Symbol]	35	<i>Juniperus chinensis</i> "Gold Coast"	Gold Coast Juniper	3 gal.			Plant @ 4' O.C.
[Symbol]	0	<i>Juniperus chinensis</i> "Spartan"	Spartan Juniper		5' ht.		Symmetrical pyramidal form
[Symbol]	35	<i>Taxus x media</i> "Densaformis"	Dense Spreading Yew	3 gal.			Plant @ 4' O.C.
EXISTING TREES TO BE REMOVED							
EXISTING TREES/SHRUBS TO BE PRESERVED							

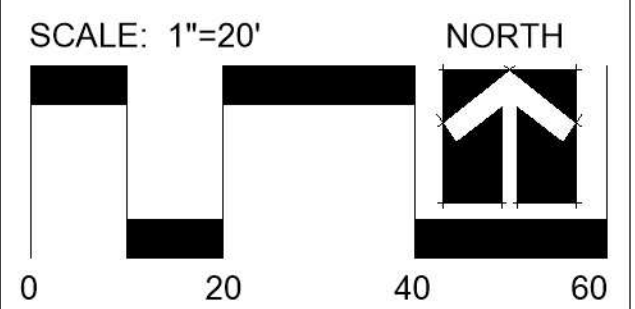

Date: 10.31.2024
 Project #: 500
 Landscape Plan

L1

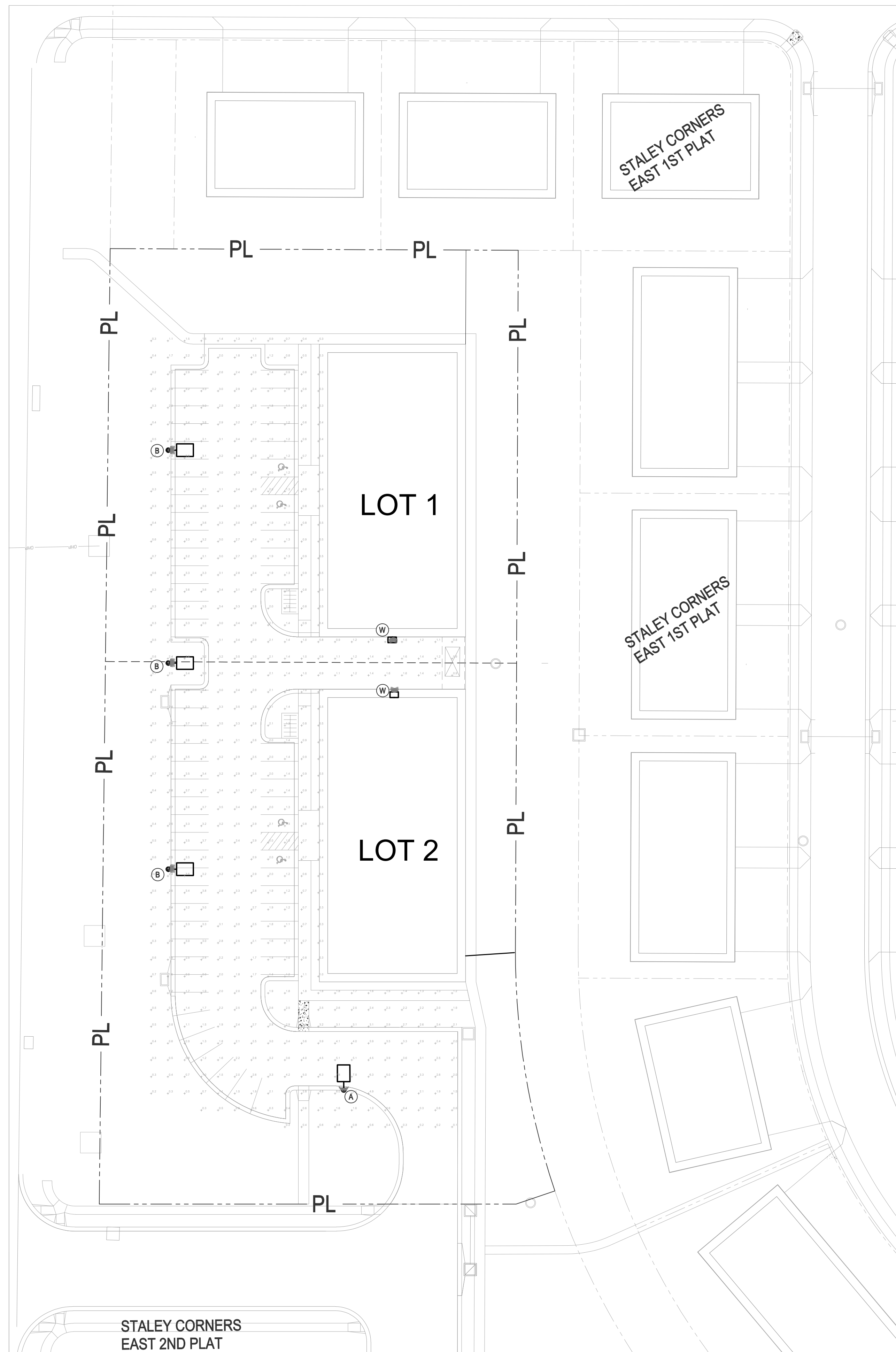

01 Site Plan
Scale: 3/8"=1'-0"

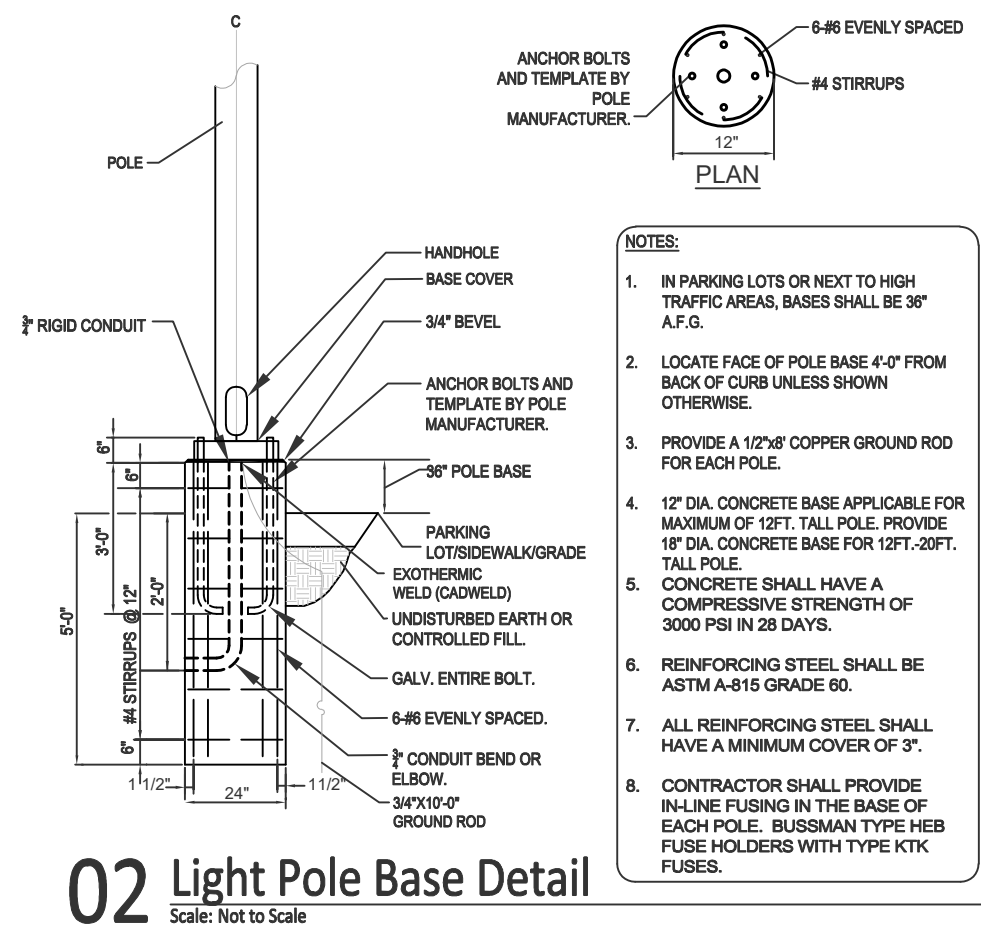
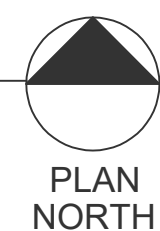

02 Light Pole Base Detail
Scale: Not to Scale

LIGHT FIXTURE SCHEDULE

MARK	MANUFACTURER	MODEL						Site Lighting		
			QUAN.	HEADS TYPE	VOLTS	MOUNTING	TOTAL WATTS	DESCRIPTION	NOTES	MARK
A	COOPER	GALN-SA6-735-120-SL3-BPC	1	MA1038	120	25' POLE	321	SINGLE HEAD POLE MOUNTED FIXTURE	2,3,4,5	A
B	COOPER	GALN-SA6-735-120-TW4-HSS-BPC	1	MA1039	120	25' POLE	321	SINGLE HEAD POLE MOUNTED FIXTURE	1,2,3,4,5	B
W	COOPER	ISC-SA1-730-U-SL4-TR-HSS-BPC	1	52W LED	120	WALL	45.2	WALL MOUNTED EXTERIOR LED FIXTURE - FULL CUTOFF	1,2,3	W

- NOTES:**
1. PROVIDE WITH HOUSESIDE SHIELD
 2. PROVIDE WITH FIXTURE MOUNTED PHOTOCELL FOR DUST TO DAWN CONTROL
 3. COLOR AS SELECTED BY ARCHITECT
 4. CONTRACTOR TO VERIFY TENON SIZE
 5. PROVIDE WITH 25' POLES STRUCTURALLY DESIGNED FOR HEAD QUANTITY.
- GENERAL NOTES:**
- A. PROVIDE ALL REQUIRED ACCESSORIES FOR A COMPLETE INSTALLATION.

VISUAL PHOTOMETRIC STATISTICS

CALC ZONE	DISCRPTION	AVERAGE	MAX	MIN	MAX/MIN	AVE/MIN	NOTES
1	PARKING AREA	25' POLE WITH 3' CONCRETE BASE	2	8.1	0.1	80.1	2.0.1

IES RECOMMENDED	Enhanced Security	Basic min
Min Horizontal Illuminance	0.5 fc	.2 fc
Max to Min	15:1	20:1
Min Vertical	0.25 fc	0.1 fc
Avg Horizontal	2.5 fc	1

POWER MATERIAL NOTES.

- CONDUIT (exterior above grade) - shall be galvanized rigid with threaded fittings. Final connection to Mechanical Equipment shall be made with minimum 12" length of Liquid-Tite conduit.
- CONDUIT (interior above grade) - circuits shall be routed in EMT conduit with set-screw or compression fittings.
- CONDUIT (below slab) - shall be Schedule 40 PVC with solvent weld fittings. Change to metal conduit at floor penetration (elbow in slab shall be metal rigid conduit).
- CONDUCTORS (#10 awg & smaller) - shall be annealed soft copper, solid or stranded construction, and Code Type THWN or THHN with #12awg minimum size.
- CONDUCTORS (#8 awg & larger) - shall be annealed soft copper, compressed strand construction, and Code Type THWN-2 or THHN.
- GROUNDING (equipment) - All circuits shall be provided with Code sized equipment grounding conductor.
- SAFETY SWITCHES - shall be Square D, or approved equal, heavy duty grade safety switch in configuration noted.
- FIRE STOPPING - provide fire stopping, as manufactured by 3M or Hilti, at fire-rated construction to maintain an effective barrier against the spread of flame, smoke, and hot gases. Components shall be compatible with each other, the substrates forming openings, and the items, if any, penetrating the fire stopping under conditions of service and application, as demonstrated by the fire stopping manufacturer based on testing and field experience.

20A WIRE SIZING SCHEDULE (VOLTAGE DROP)

ALL WIRE SIZES SHOWN ON BELOW SCHEDULE ARE INTENDED TO BE MINIMUM ACCEPTABLE WIRE SIZE

THE FOLLOWING SCHEDULE IS TO BE USED TO SIZE WIRE FOR 20 AMP CIRCUITS (120 AND 277 VOLT). LENGTHS (ONE WAY) ARE INTENDED TO BE MAXIMUM.

MAX AMPS	MAX WATTS	WIRE SIZE			
		#12	#10	#8	#6
5	600	200	325	490	770
10	1200	100	160	245	385
15	1800	70	110	165	255

277 VOLT CIRCUIT MAX LENGTH (FT)

MAX AMPS	MAX WATTS	WIRE SIZE			
		#12	#10	#8	#6
5	1385	480	760	1170	1865
10	2770	240	380	585	930
15	4155	160	250	390	620



REVISIONS

No.	Description	Date

Rel. Date: 10.31.2024

SITE PLAN

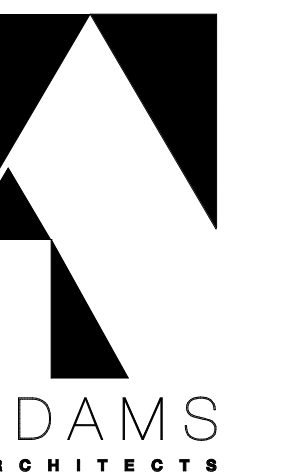

ADAMS ARCHITECTS
700 Massachusetts St.
Suite 307
Lawrence, Kansas 66044
(785) 218-3980
www.adamsarchts.com

APPROVED BY:

Name: . . .	Date: . . .
Name: . . .	Date: . . .
Name: . . .	Date: . . .

UNLESS A PROFESSIONAL SEAL WITH SIGNATURE AND DATE IS AFFIXED, THIS DOCUMENT IS PRELIMINARY AND IS NOT INTENDED FOR CONSTRUCTION.

REVISIONS

No.	Description	Date

Rel. Date: 09/25/24

BUILDING ELEVATIONS

A200

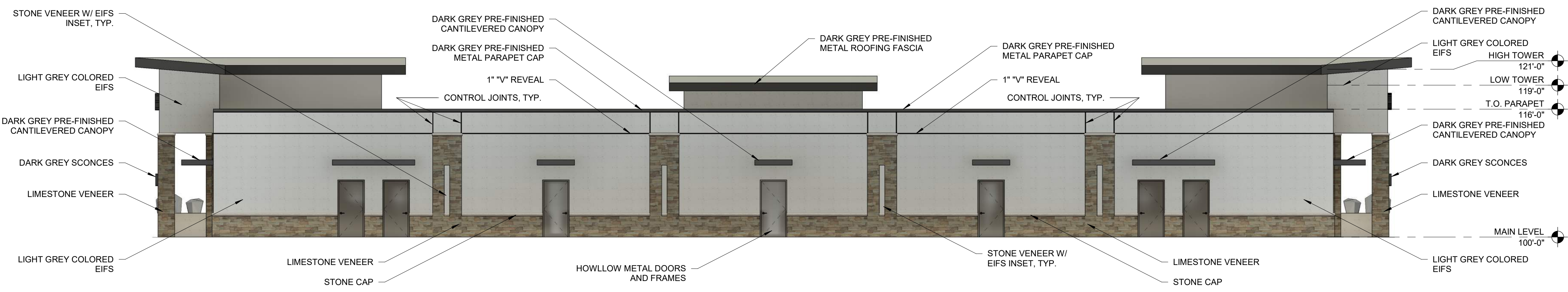

NORTH ELEVATION C1
1/8" = 1'-0"

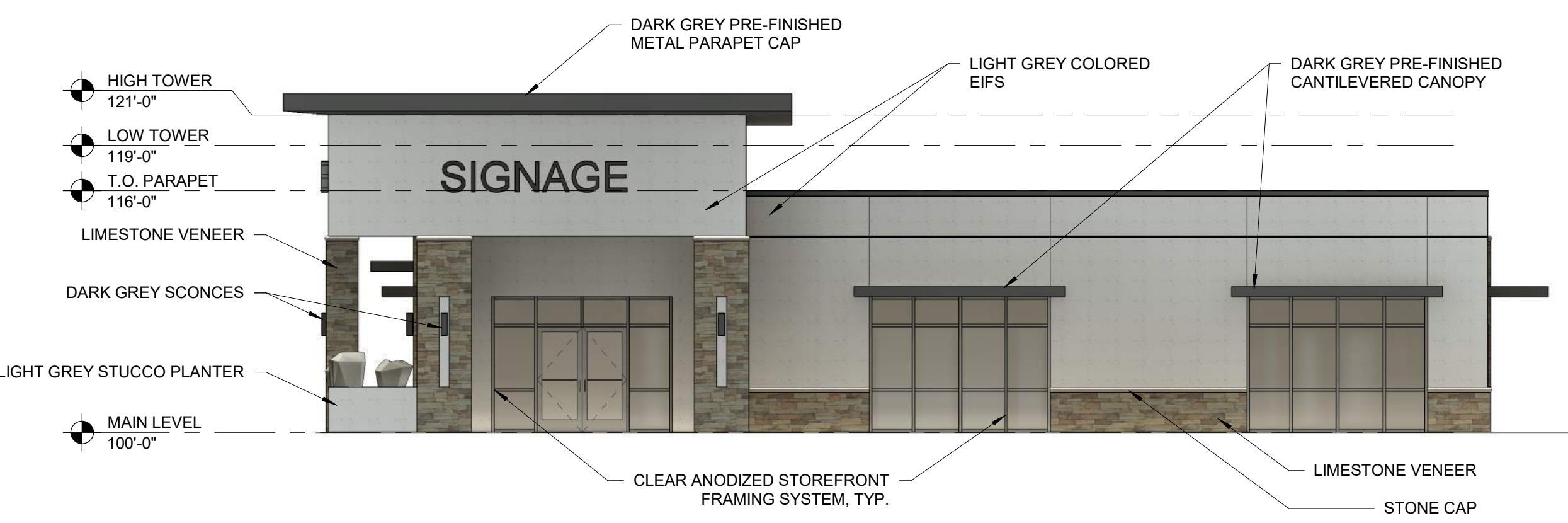

EAST ELEVATION B2
1/8" = 1'-0"



WEST ELEVATION B1
1/8" = 1'-0"

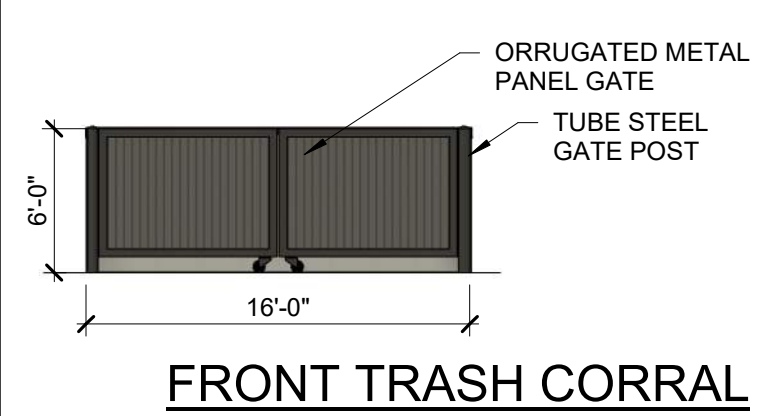
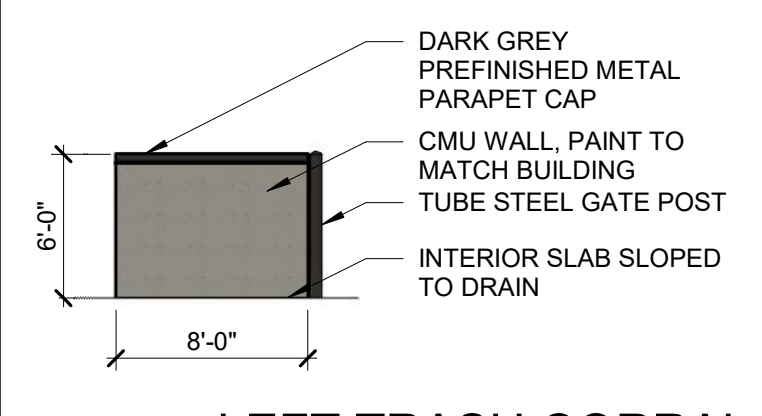
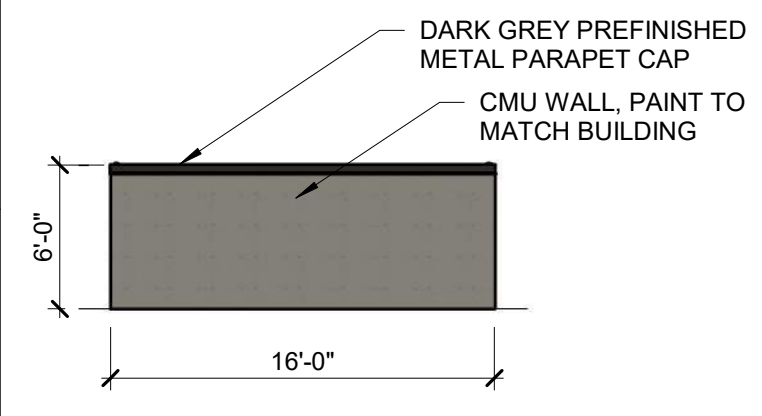
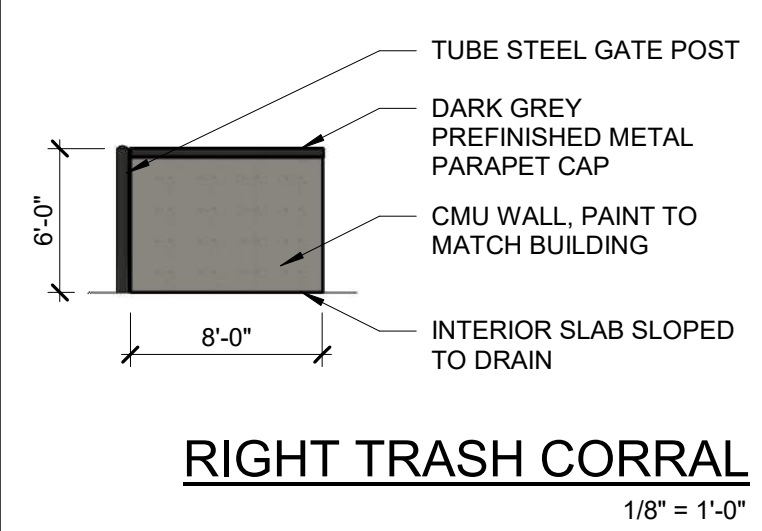

SOUTH ELEVATION A3
1/8" = 1'-0"



April 15, 2024

Mr. Justin Milburn, P.E.
Milburn Civil Engineering, LLC
33135 W. 83rd Street
De Soto, Kansas 66018

Re: Staley Corners – Kansas City, MO

Dear Mr. Milburn:

In response to your request, Priority Engineers, Inc. has reviewed the current Staley Corners site plan and compared it to the approved Staley Corners Traffic Impact Study, which was dated July 11, 2019.

There are two changes that are being considered at this time. The first is on the east side of Indiana Avenue and is to replace the recent plan for a retirement home with two 9,800 square foot commercial buildings. The approved study included 44,300 square feet of retail, with no retirement home, compared to the current plan which includes 39,600 square feet. Because the retirement home was a lower generating use than commercial uses, the study was not updated for the retirement hope plan, and the change back to retail is actually reverting back to near what was approved in the 2019 traffic study.

The second change will occur on the west side of Indiana Avenue with the current change to include a 3,750 square foot McDonald's. In the approved study, the west side included 78,800 square feet of retail and 17,850 square feet of high-turnover sit-down restaurant. As it has developed, the retail has decreased, and the sit-down restaurant has been replaced with a Quick Lubrication Vehicle Shop, a drive-through coffee shop, and McDonald's. Table 1 below shows the trip generation for the impacted area as it was assumed in the approved 2019 traffic study.

Table 1: Trip Generation, Approved Traffic Study for Impacted Area								
Land Use	Intensity	Daily	AM Peak			PM Peak		
			Total	In	Out	Total	In	Out
Shopping Center	78,800 SF	5113	191	118	73	456	219	237
High Turnover (Sit-Down) Restaurant	17,850 SF	2002	177	97	80	174	108	66
Total		7,115	368	215	153	630	327	303

Table 2 below shows the trip generation, using the most recent Trip Generation Manual 11th Edition, for the currently proposed plan for the impacted area.

Table 2: Trip Generation, 11th Edition For Impacted Area								
Land Use	Intensity	Daily	AM Peak			PM Peak		
			Total	In	Out	Total	In	Out
Shopping Plaza (40-150k)	62,000 SF	4243	107	67	40	322	158	164
Quick Lubrication Vehicle Shop	1,800 SF	125	10	8	2	16	7	9
Coffee/Donut Shop with Drive-Through Window and no Indoor Seating	2 lanes	358	89	44	45	30	15	15
Fast-Food Restaurant with Drive-Through Window	3,750 SF	1753	167	85	82	124	64	60
Total		6,422	373	204	169	492	244	248

For the western portion of the development, the AM Peak Hour trip generation increased by 5 trips, while both the daily and PM Peak Hour decreased significantly.

Sincerely,

PRIORITY ENGINEERS, INC.

Kristin L. Skinner, P.E., PTOE
President



CITY PLANNING & DEVELOPMENT

Public Meeting Summary Form

Project Case #

Meeting Date:

Meeting Location:

Meeting Time (include start and end time):

Additional Comments (optional):

Meeting Sign-In Sheet

Project Name and Address

Name	Address	Phone	Email
No Attendees			